

AIR CONDITIONING

2010 Chevrolet Camaro LS

2010 SYSTEM WIRING DIAGRAMS Chevrolet - Camaro

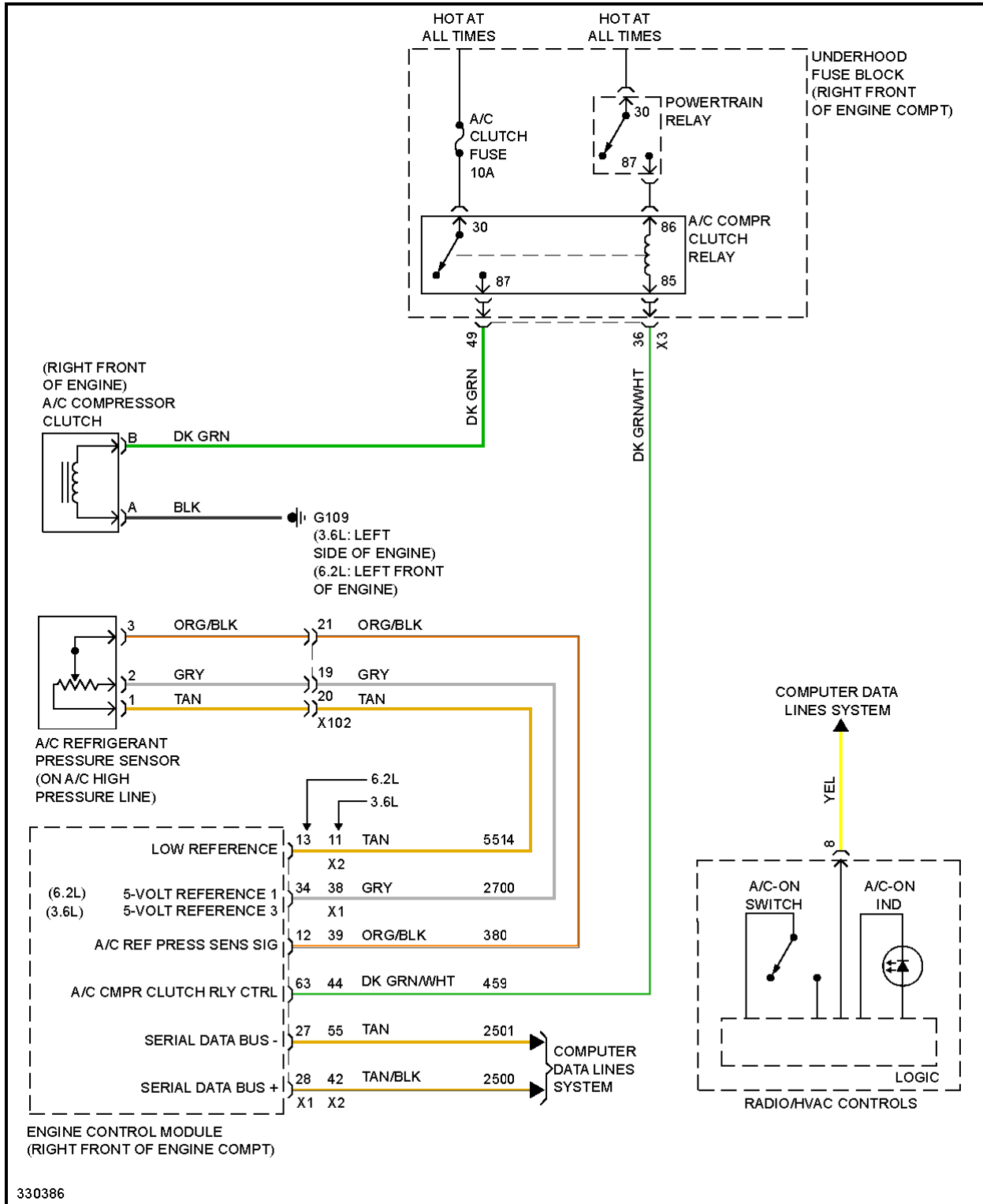

2010 Chevrolet Camaro LS

2010 SYSTEM WIRING DIAGRAMS Chevrolet - Camaro

Fig. 1: Compressor Circuit

2010 Chevrolet Camaro LS

2010 SYSTEM WIRING DIAGRAMS Chevrolet - Camaro

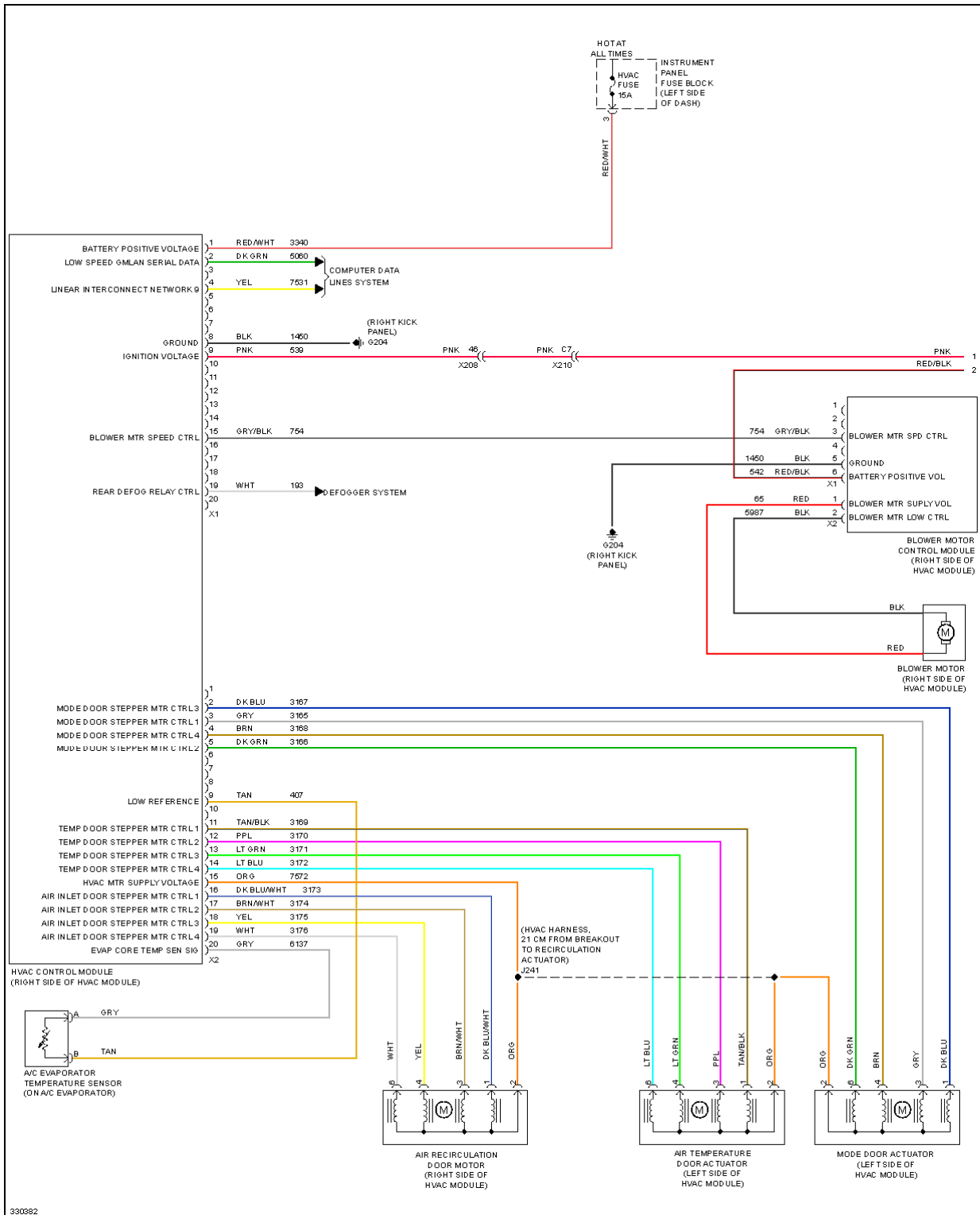

2010 Chevrolet Camaro LS

2010 SYSTEM WIRING DIAGRAMS Chevrolet - Camaro

Fig. 2: Manual A/C Circuit (1 of 2)

2010 Chevrolet Camaro LS

2010 SYSTEM WIRING DIAGRAMS Chevrolet - Camaro

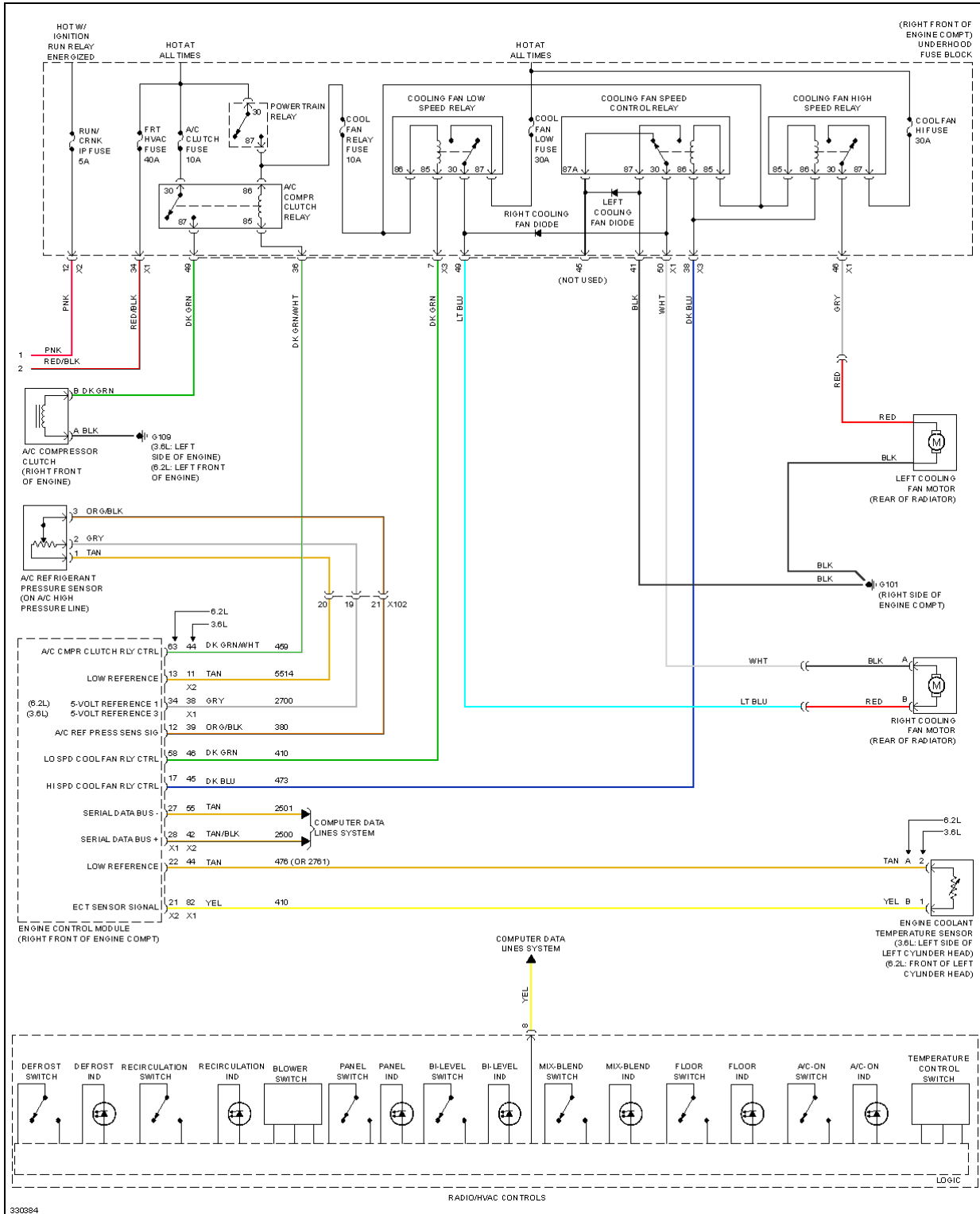

Fig. 3: Manual A/C Circuit (2 of 2)

ANTI-LOCK BRAKES

2010 Chevrolet Camaro LS

2010 SYSTEM WIRING DIAGRAMS Chevrolet - Camaro

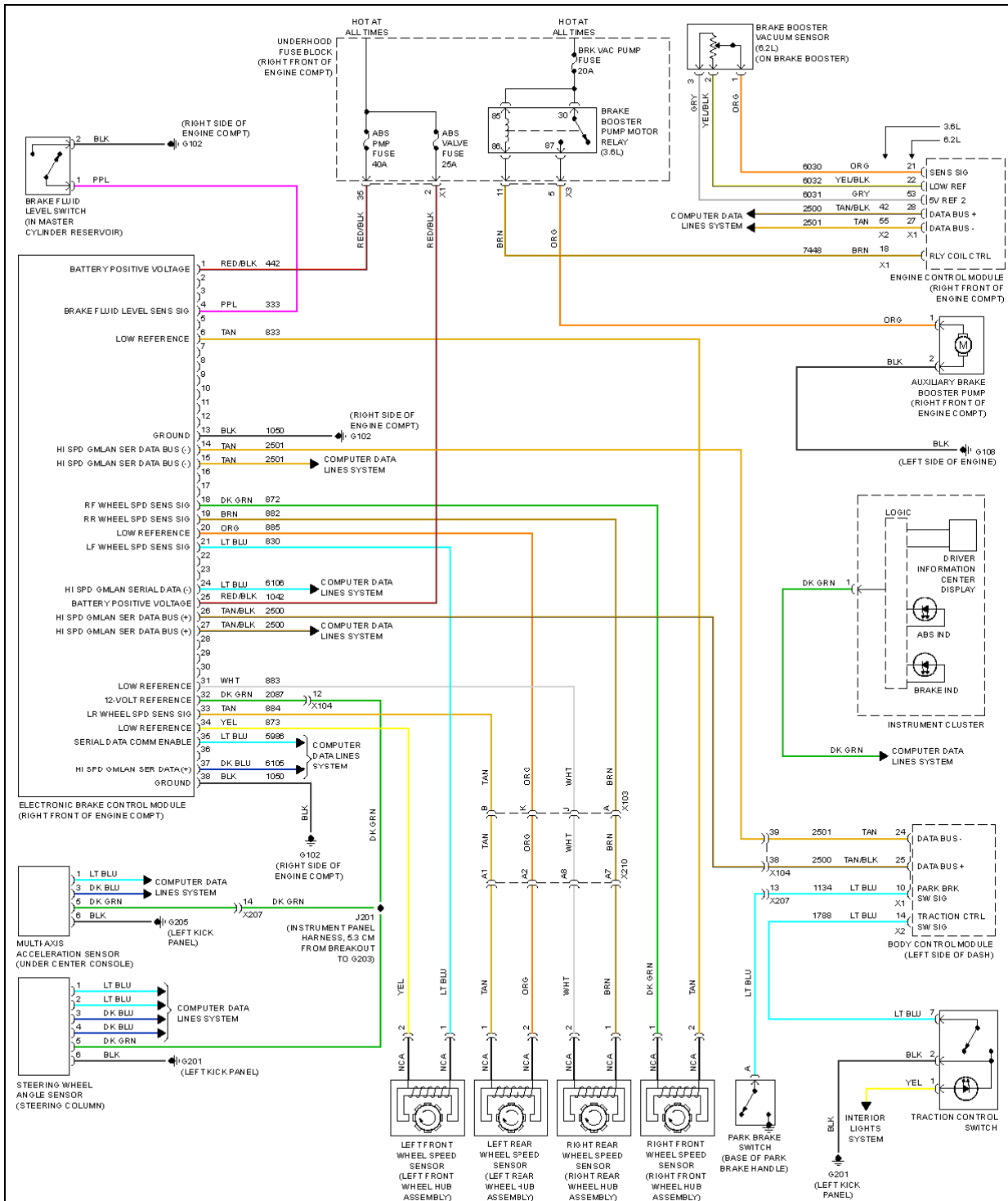
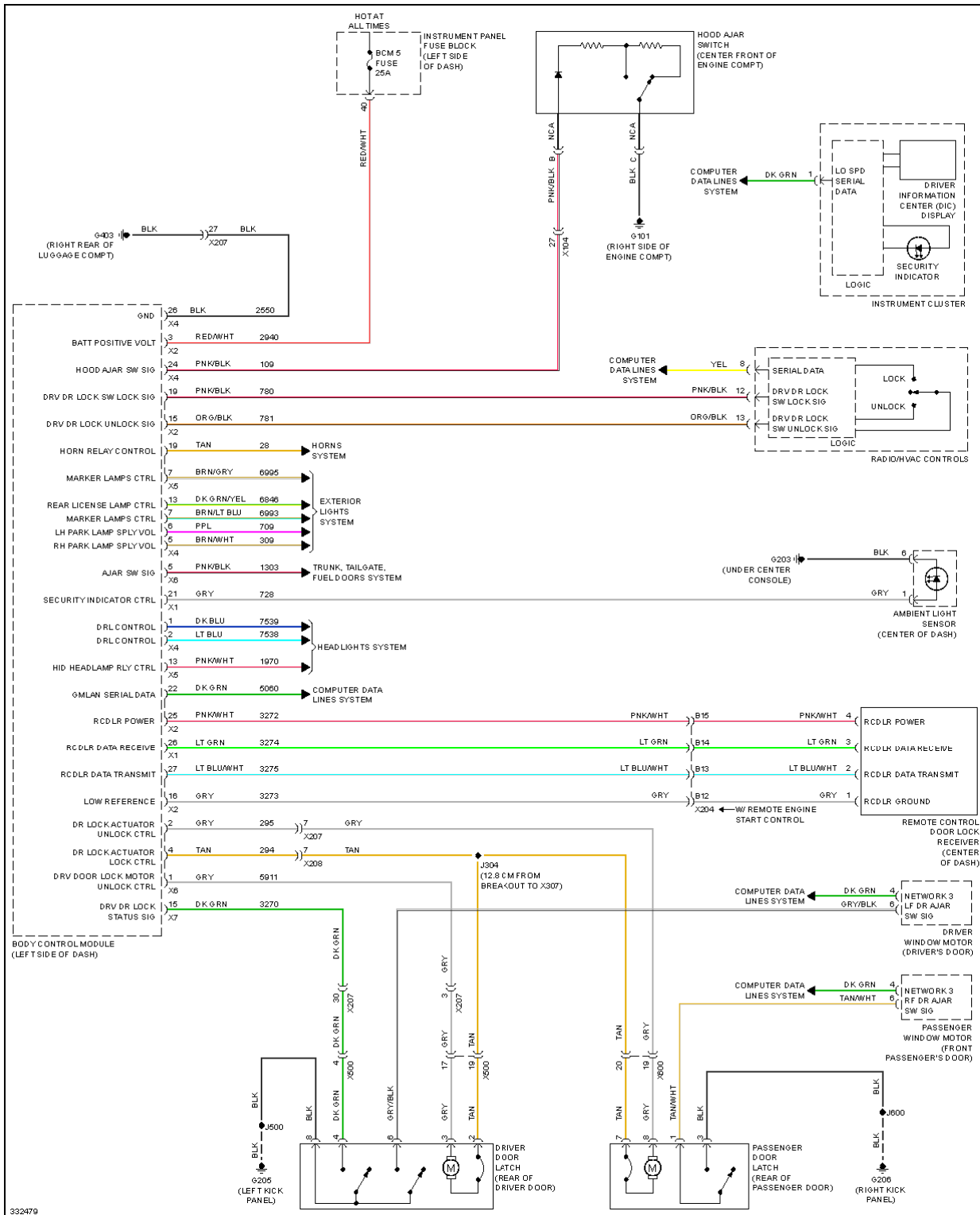

Fig. 4: Anti-lock Brakes Circuit

ANTI-THEFT

2010 Chevrolet Camaro LS

2010 SYSTEM WIRING DIAGRAMS Chevrolet - Camaro



2010 Chevrolet Camaro LS

2010 SYSTEM WIRING DIAGRAMS Chevrolet - Camaro

Fig. 5: Forced Entry Circuit

2010 Chevrolet Camaro LS

2010 SYSTEM WIRING DIAGRAMS Chevrolet - Camaro

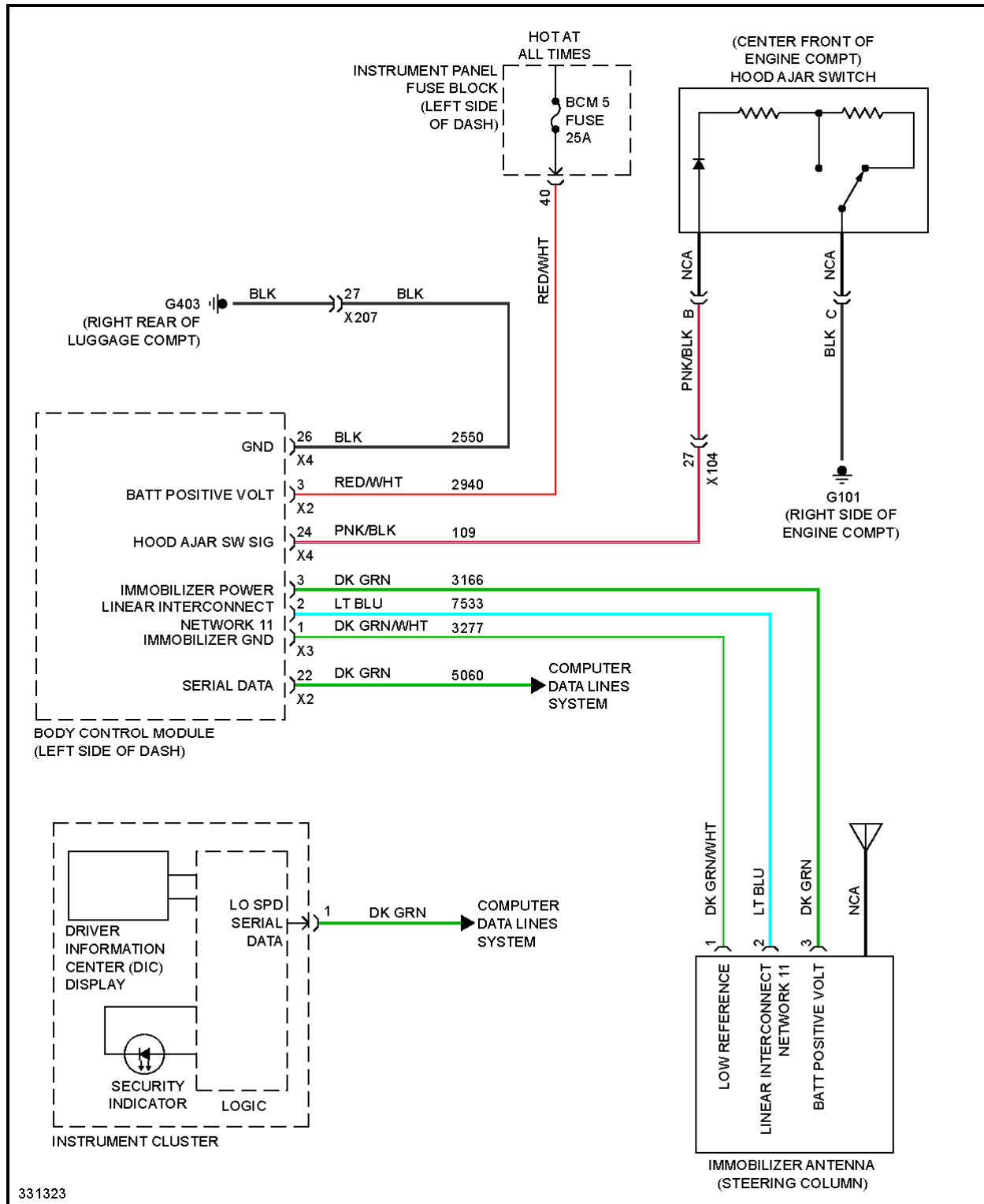
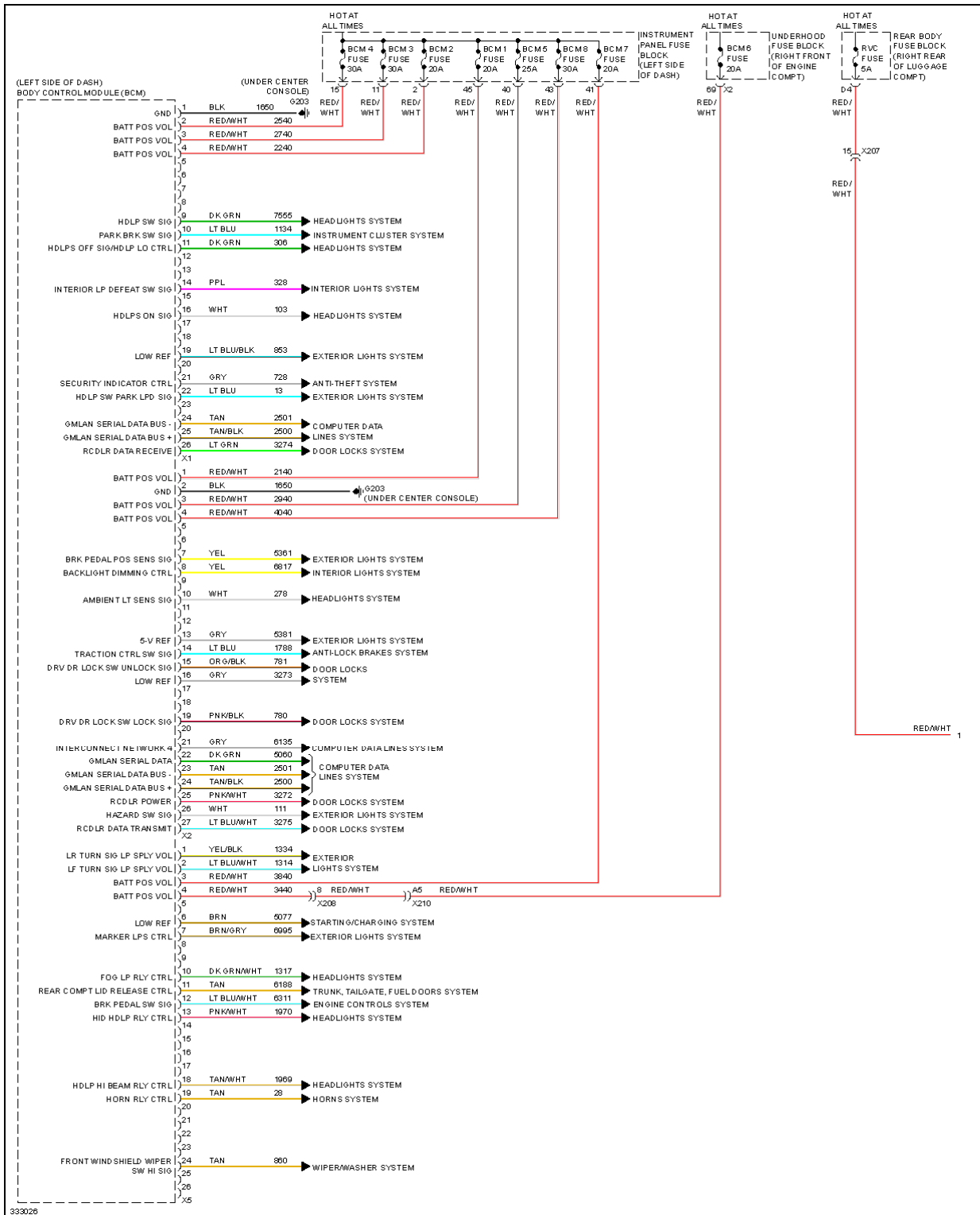

Fig. 6: Pass-Key Circuit

BODY CONTROL MODULES

2010 Chevrolet Camaro LS

2010 SYSTEM WIRING DIAGRAMS Chevrolet - Camaro



2010 Chevrolet Camaro LS

2010 SYSTEM WIRING DIAGRAMS Chevrolet - Camaro

Fig. 7: Body Control Modules Circuit (1 of 2)

Fig. 8: Body Control Modules Circuit (2 of 2)

COMPUTER DATA LINES

2010 Chevrolet Camaro LS

2010 SYSTEM WIRING DIAGRAMS Chevrolet - Camaro

Fig. 9: Computer Data Lines Circuit (1 of 2)

2010 Chevrolet Camaro LS

2010 SYSTEM WIRING DIAGRAMS Chevrolet - Camaro

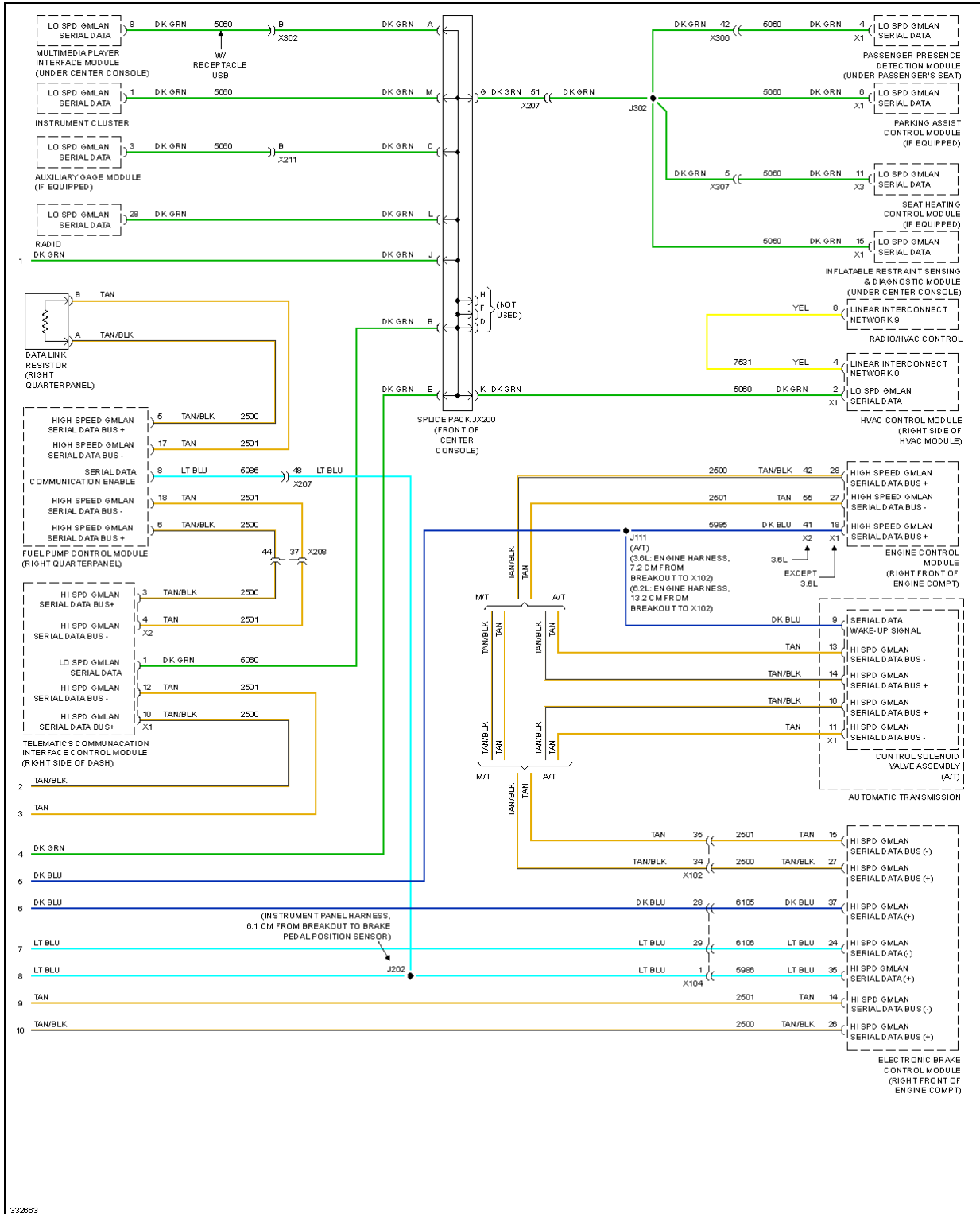

Fig. 10: Computer Data Lines Circuit (2 of 2)

COOLING FAN

2010 Chevrolet Camaro LS

2010 SYSTEM WIRING DIAGRAMS Chevrolet - Camaro

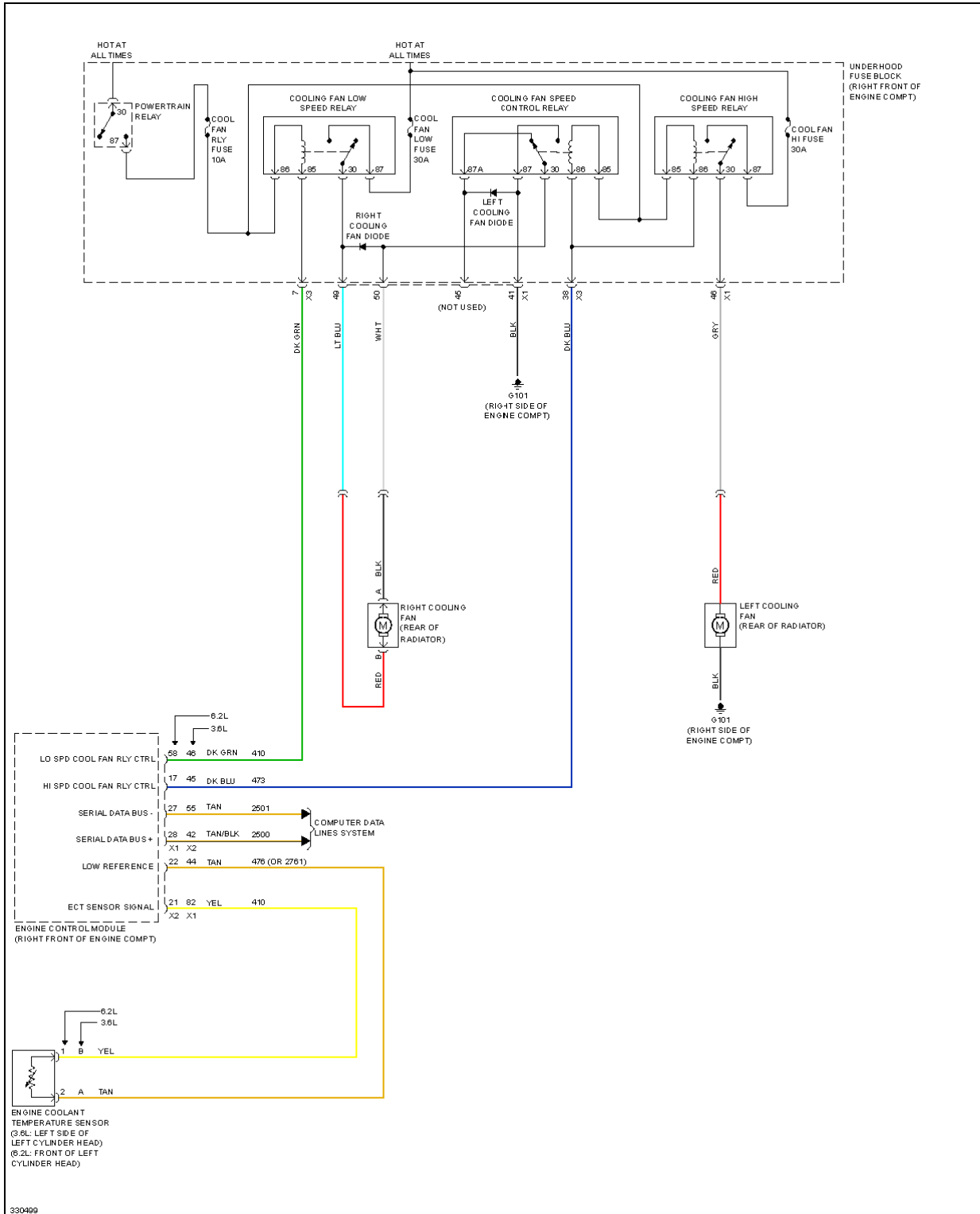

Fig. 11: Cooling Fan Circuit

CRUISE CONTROL

2010 Chevrolet Camaro LS

2010 SYSTEM WIRING DIAGRAMS Chevrolet - Camaro

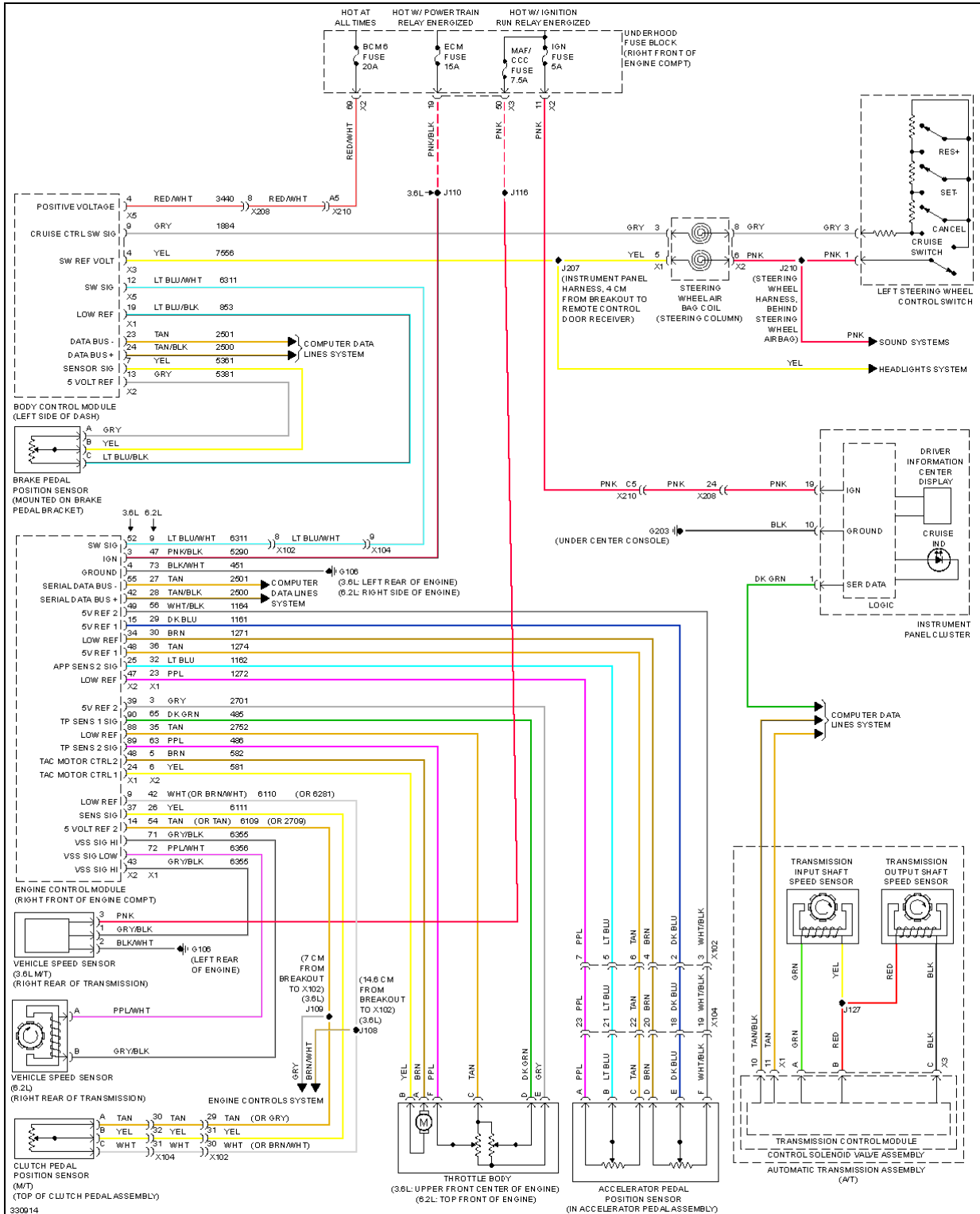

Fig. 12: Cruise Control Circuit

DEFOGGERS

2010 Chevrolet Camaro LS

2010 SYSTEM WIRING DIAGRAMS Chevrolet - Camaro

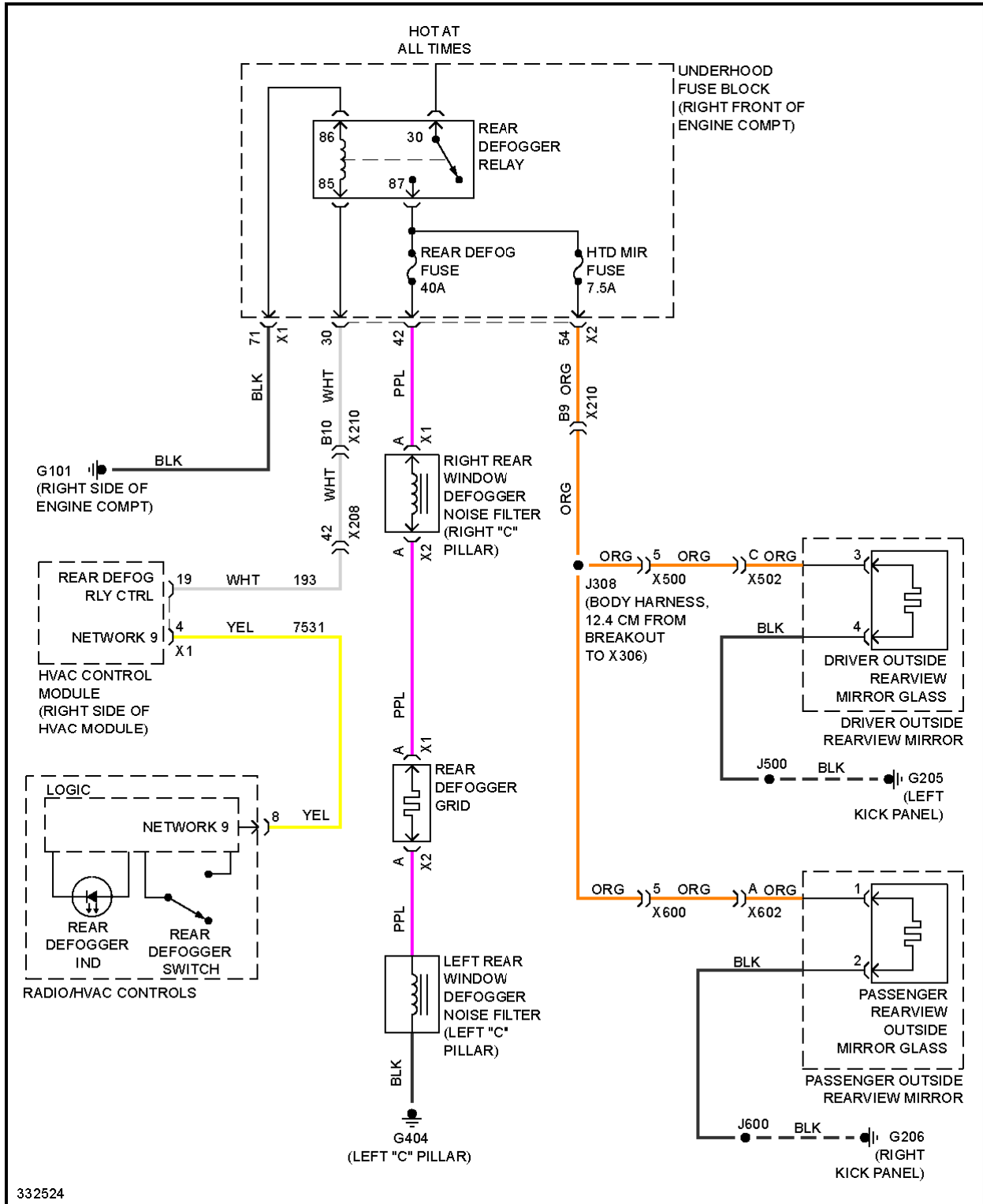

Fig. 13: Defoggers Circuit

ENGINE PERFORMANCE

3.6L VIN V

2010 Chevrolet Camaro LS

2010 SYSTEM WIRING DIAGRAMS Chevrolet - Camaro

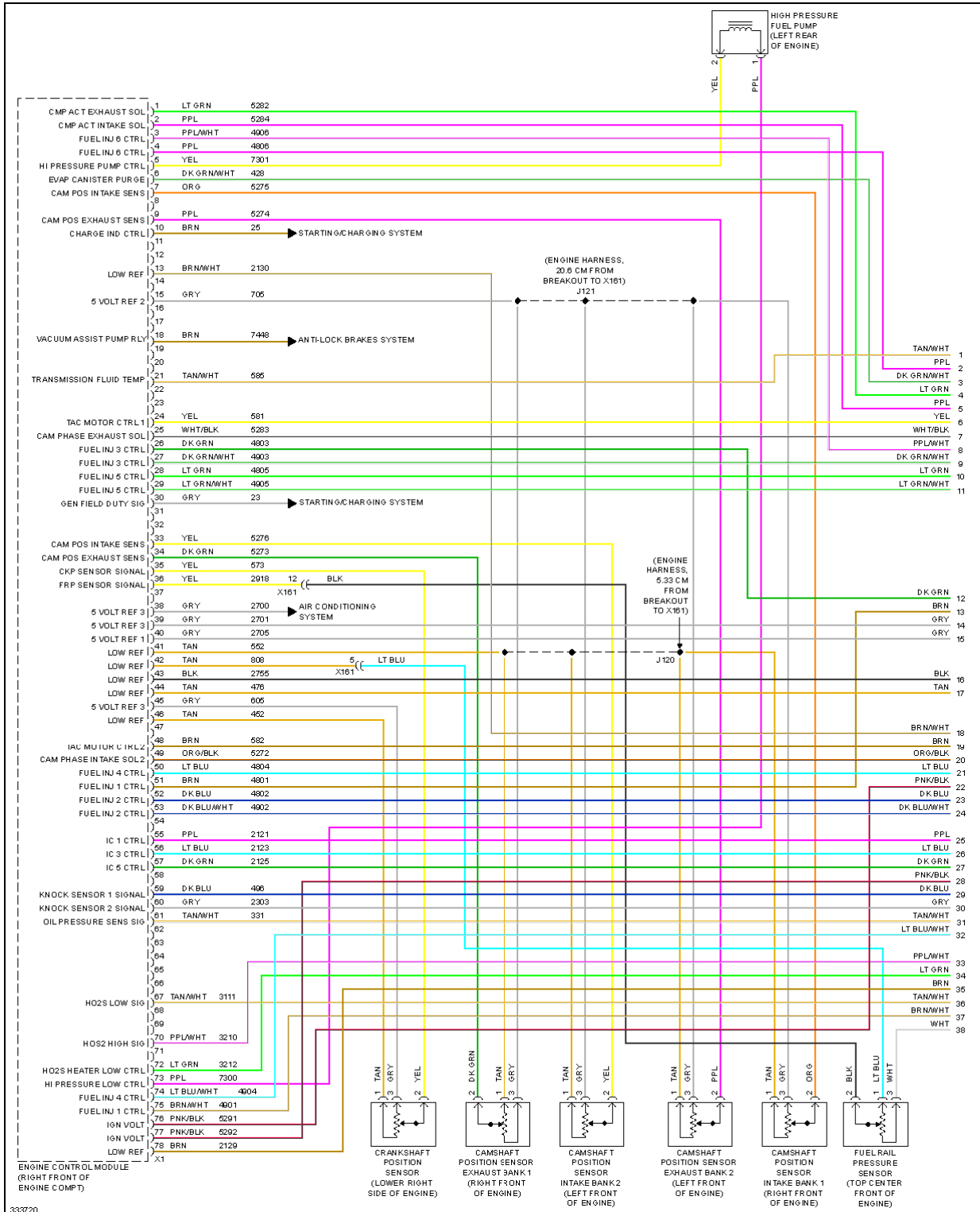

2010 Chevrolet Camaro LS

2010 SYSTEM WIRING DIAGRAMS Chevrolet - Camaro

Fig. 14: 3.6L VIN V, Engine Performance Circuit (1 of 6)

2010 Chevrolet Camaro LS

2010 SYSTEM WIRING DIAGRAMS Chevrolet - Camaro

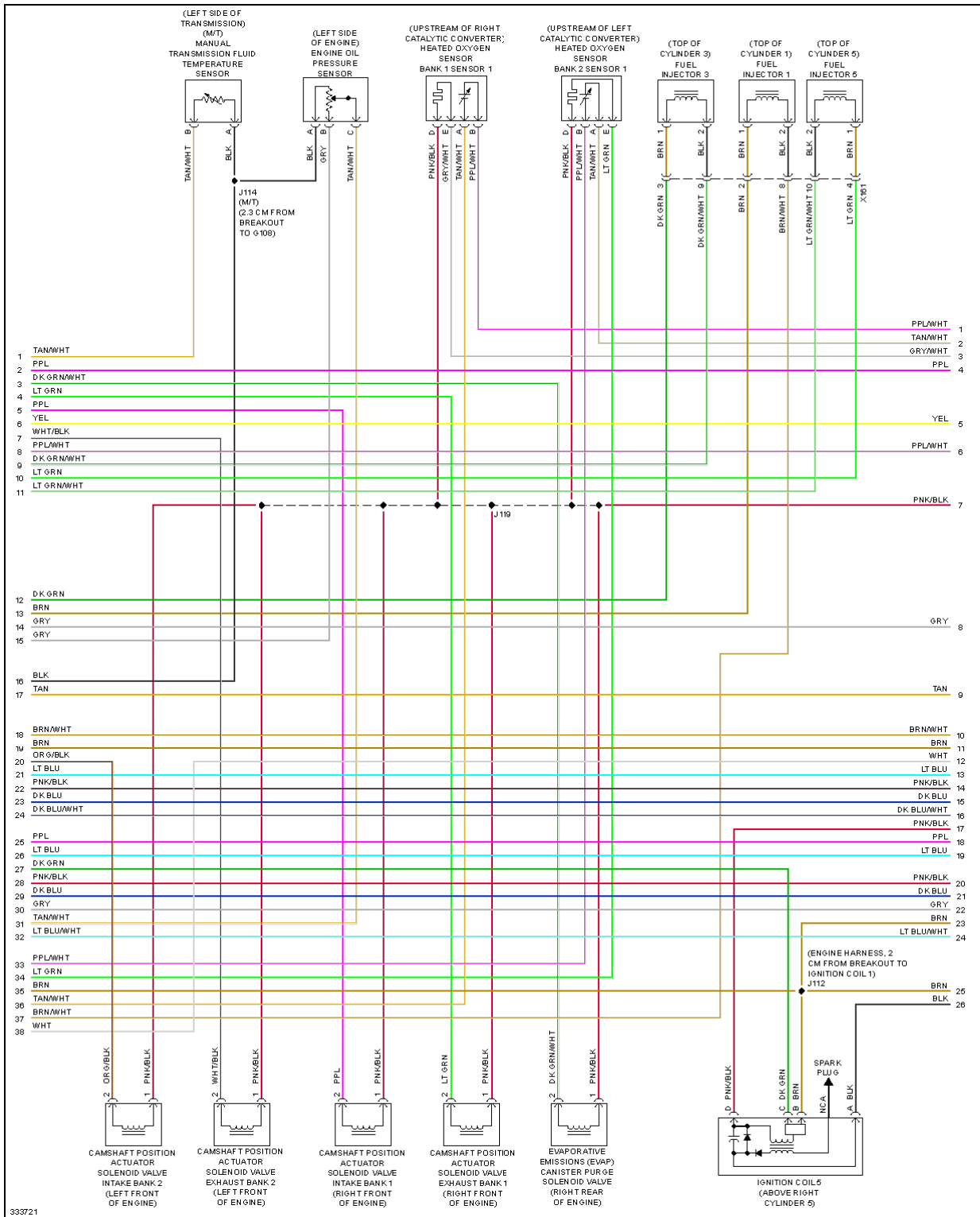

2010 Chevrolet Camaro LS

2010 SYSTEM WIRING DIAGRAMS Chevrolet - Camaro

Fig. 15: 3.6L VIN V, Engine Performance Circuit (2 of 6)

2010 Chevrolet Camaro LS

2010 SYSTEM WIRING DIAGRAMS Chevrolet - Camaro

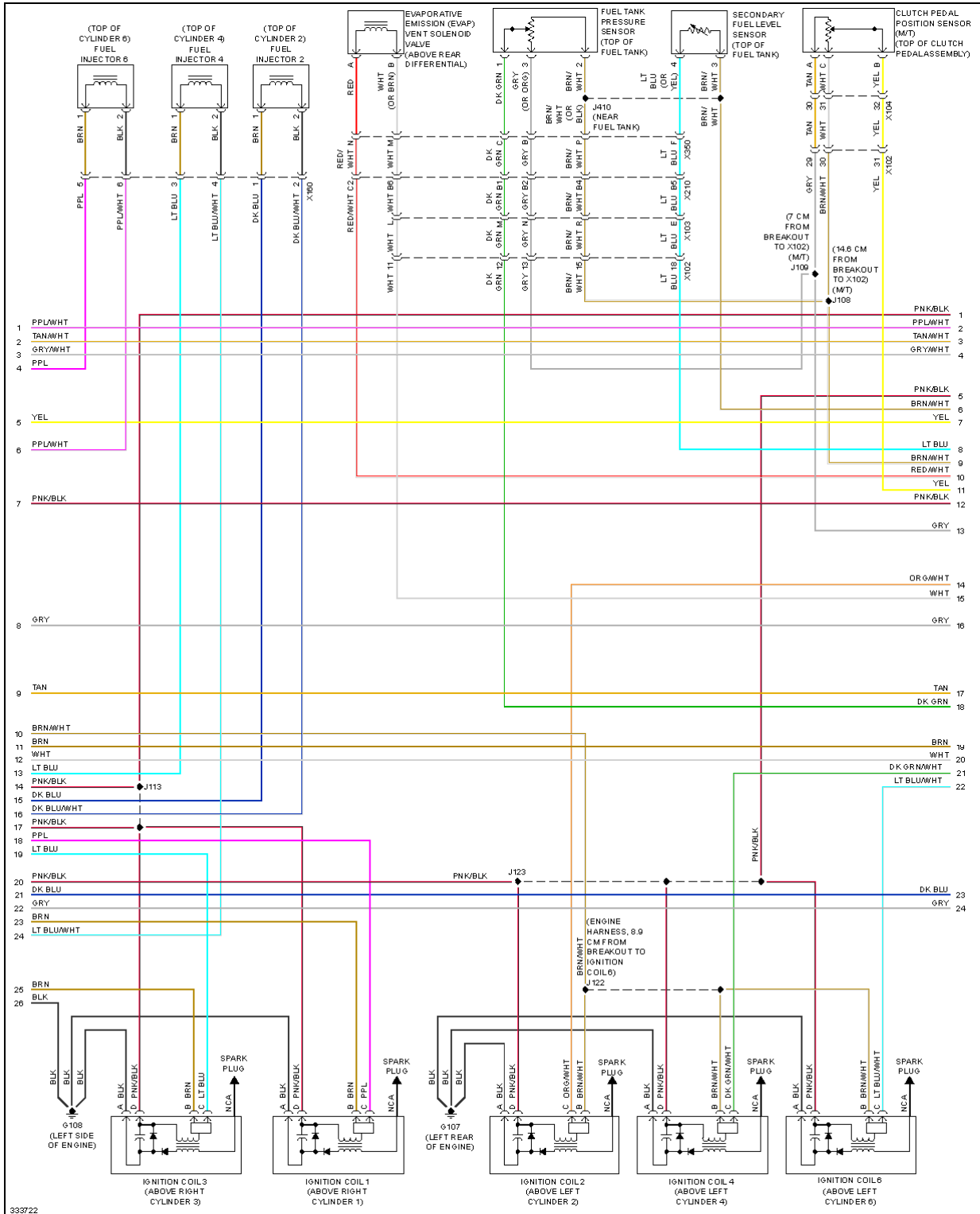

2010 Chevrolet Camaro LS

2010 SYSTEM WIRING DIAGRAMS Chevrolet - Camaro

Fig. 16: 3.6L VIN V, Engine Performance Circuit (3 of 6)

2010 Chevrolet Camaro LS

2010 SYSTEM WIRING DIAGRAMS Chevrolet - Camaro

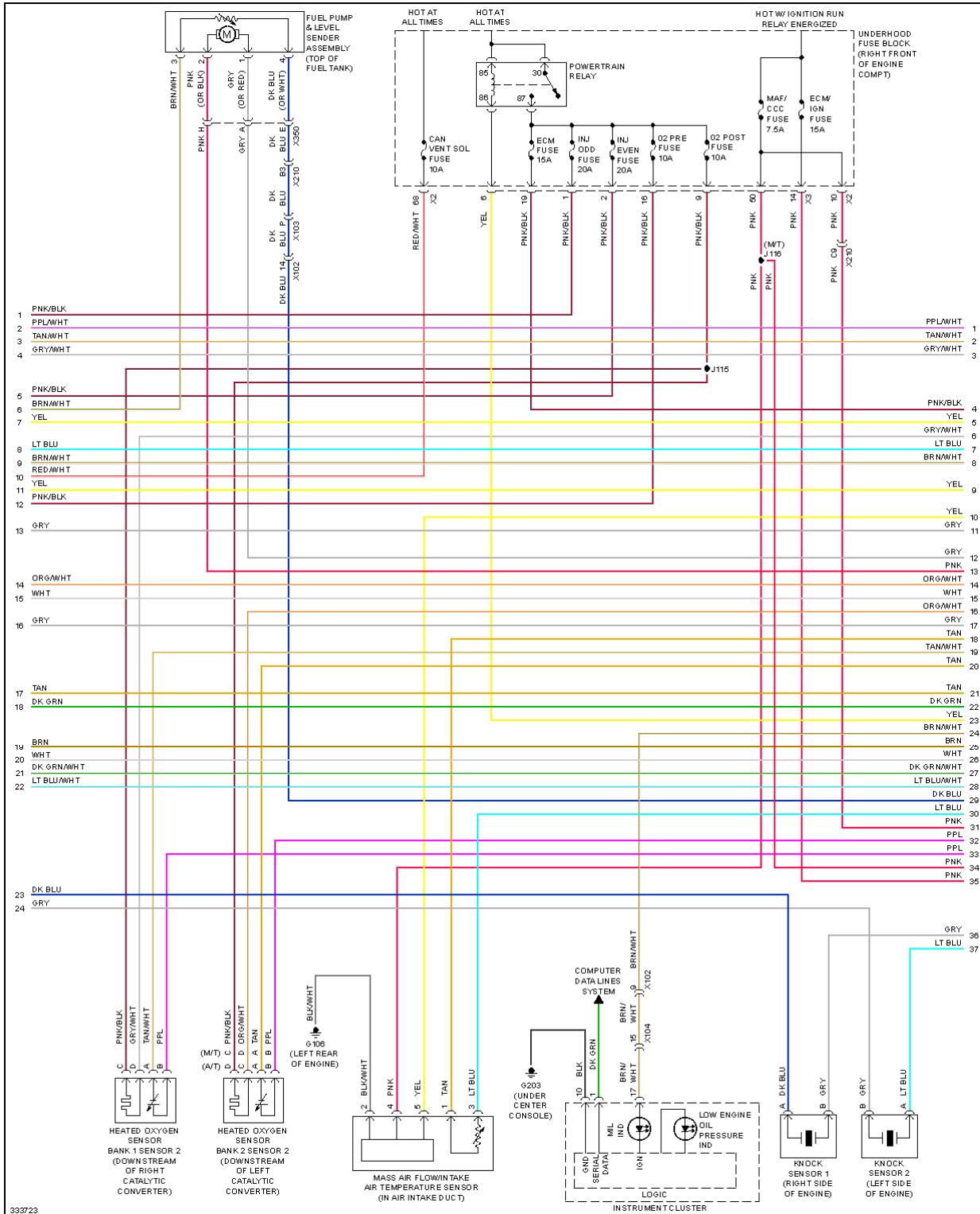

2010 Chevrolet Camaro LS

2010 SYSTEM WIRING DIAGRAMS Chevrolet - Camaro

Fig. 17: 3.6L VIN V, Engine Performance Circuit (4 of 6)

2010 Chevrolet Camaro LS

2010 SYSTEM WIRING DIAGRAMS Chevrolet - Camaro

Fig. 18: 3.6L VIN V, Engine Performance Circuit (5 of 6)

2010 Chevrolet Camaro LS

2010 SYSTEM WIRING DIAGRAMS Chevrolet - Camaro

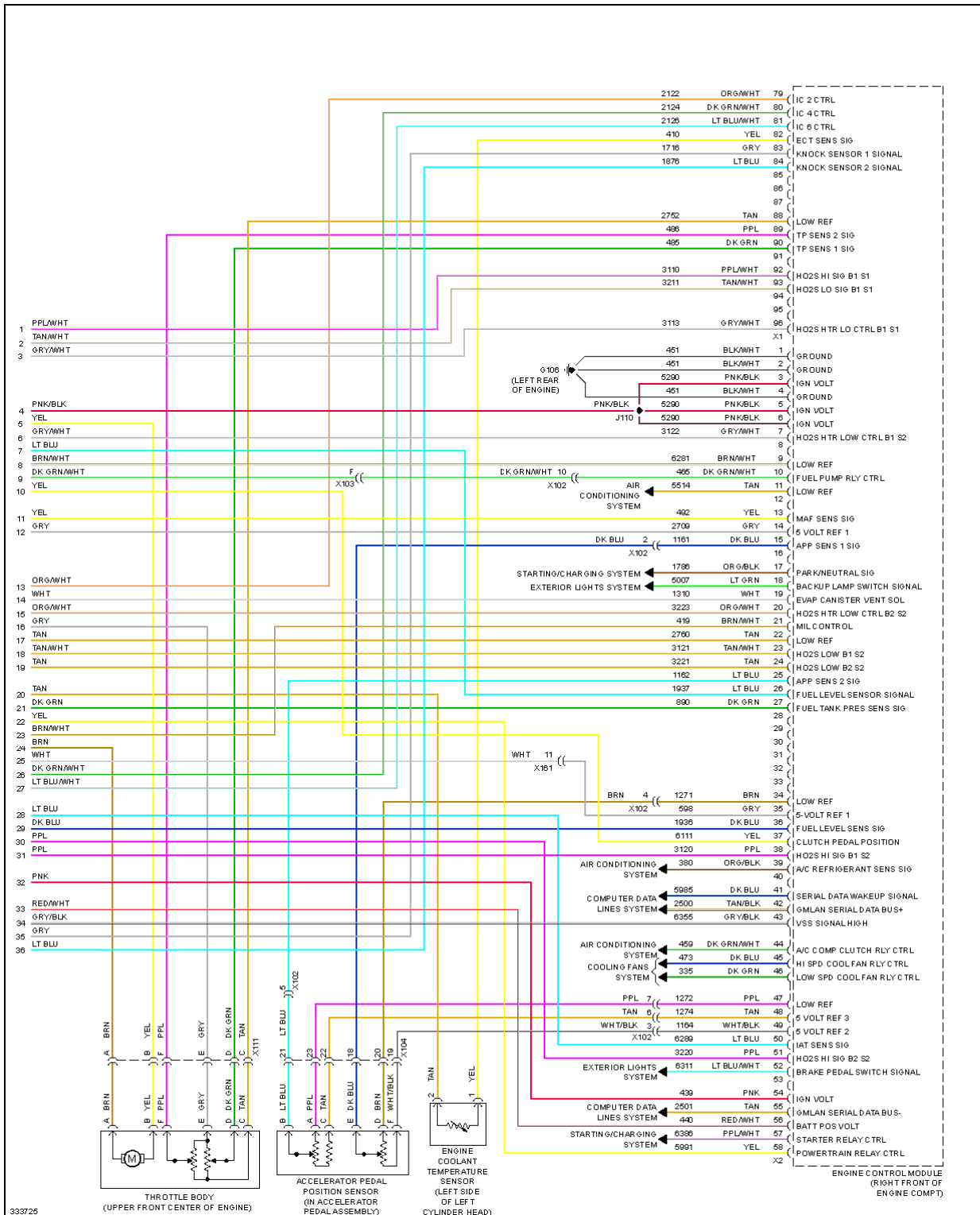
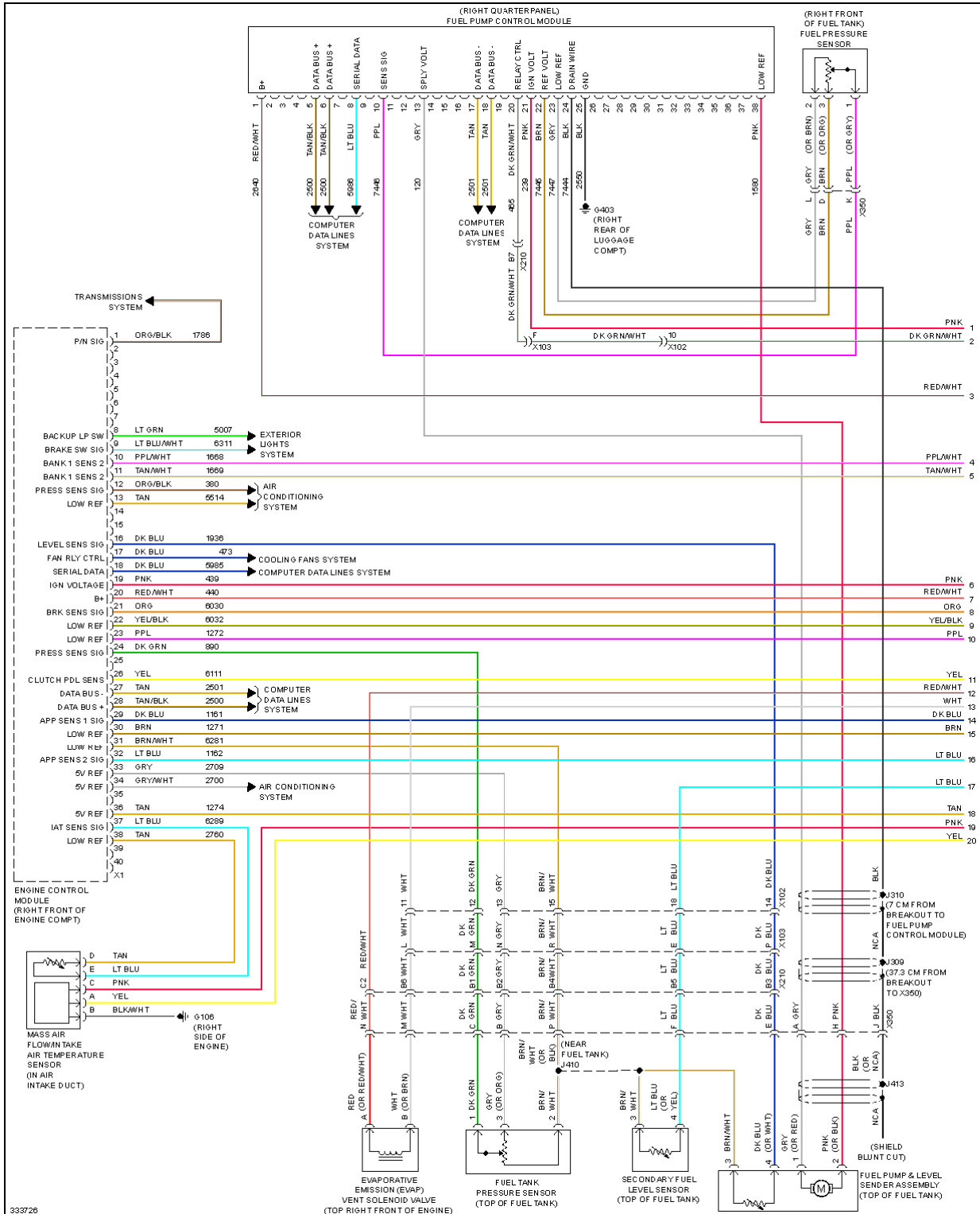

Fig. 19: 3.6L VIN V, Engine Performance Circuit (6 of 6)

6.2L VIN J

2010 Chevrolet Camaro LS

2010 SYSTEM WIRING DIAGRAMS Chevrolet - Camaro



2010 Chevrolet Camaro LS

2010 SYSTEM WIRING DIAGRAMS Chevrolet - Camaro

Fig. 20: 6.2L VIN J, Engine Performance Circuit (1 of 6)

2010 Chevrolet Camaro LS

2010 SYSTEM WIRING DIAGRAMS Chevrolet - Camaro

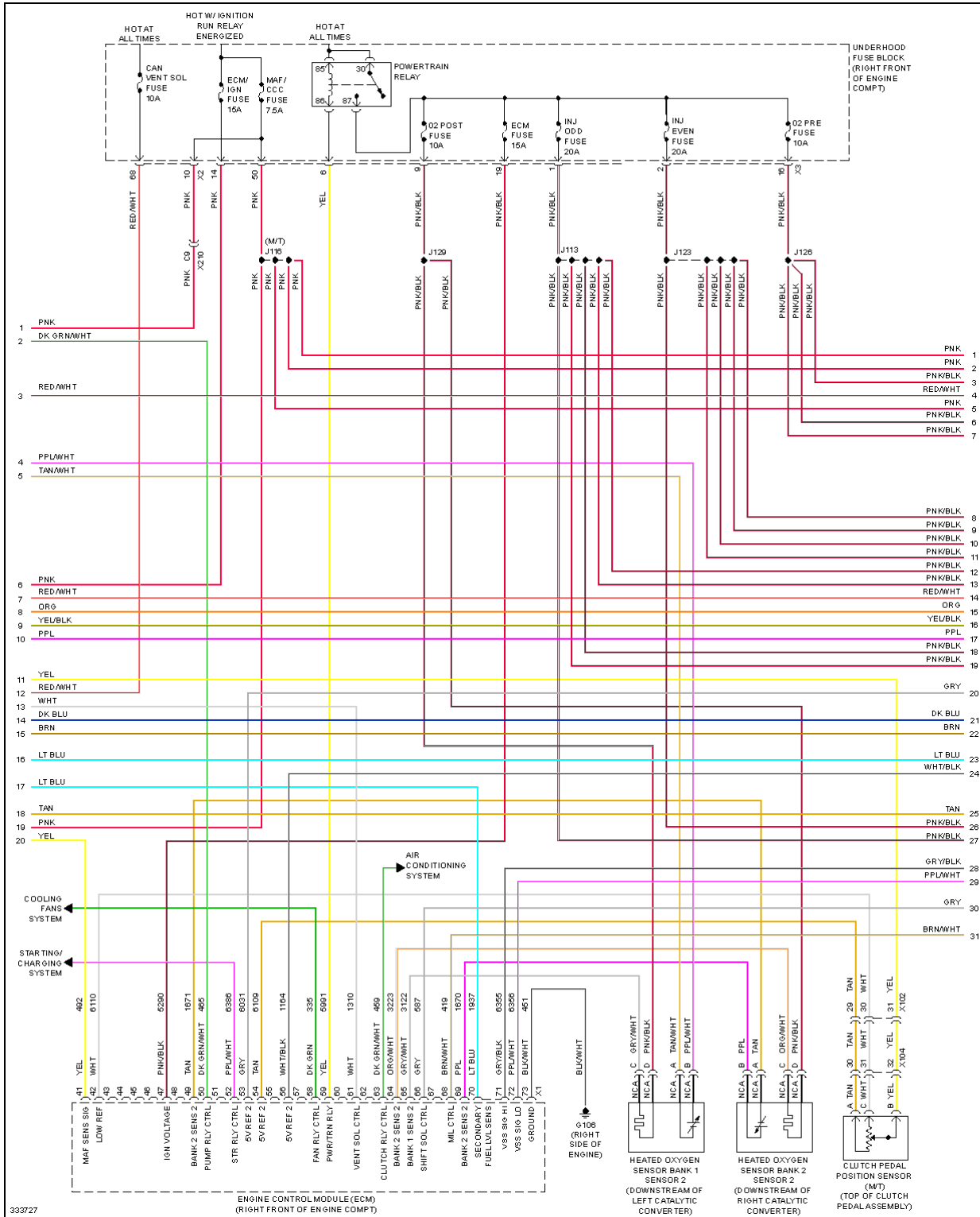

2010 Chevrolet Camaro LS

2010 SYSTEM WIRING DIAGRAMS Chevrolet - Camaro

Fig. 21: 6.2L VIN J, Engine Performance Circuit (2 of 6)

2010 Chevrolet Camaro LS

2010 SYSTEM WIRING DIAGRAMS Chevrolet - Camaro

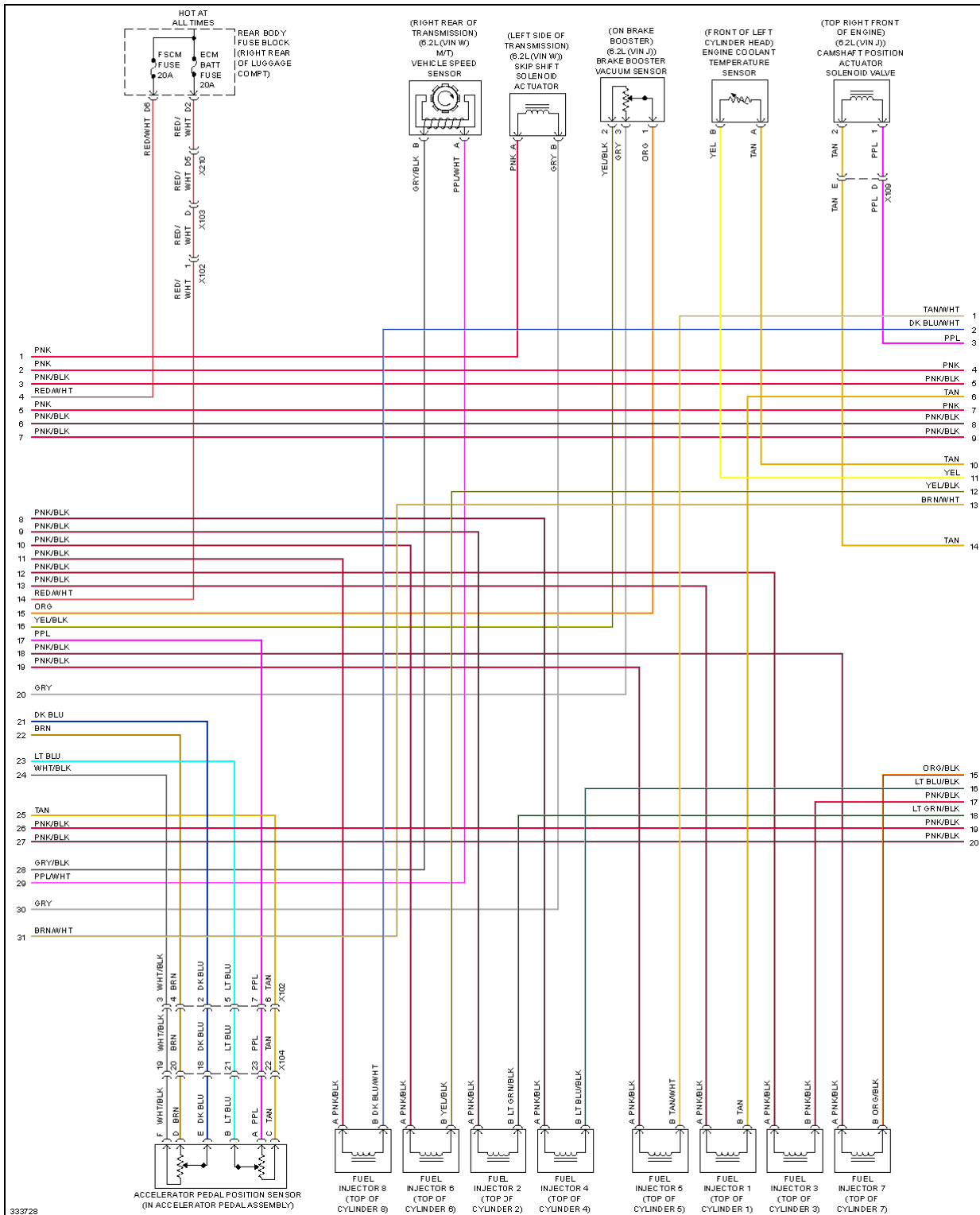

2010 Chevrolet Camaro LS

2010 SYSTEM WIRING DIAGRAMS Chevrolet - Camaro

Fig. 22: 6.2L VIN J, Engine Performance Circuit (3 of 6)

2010 Chevrolet Camaro LS

2010 SYSTEM WIRING DIAGRAMS Chevrolet - Camaro

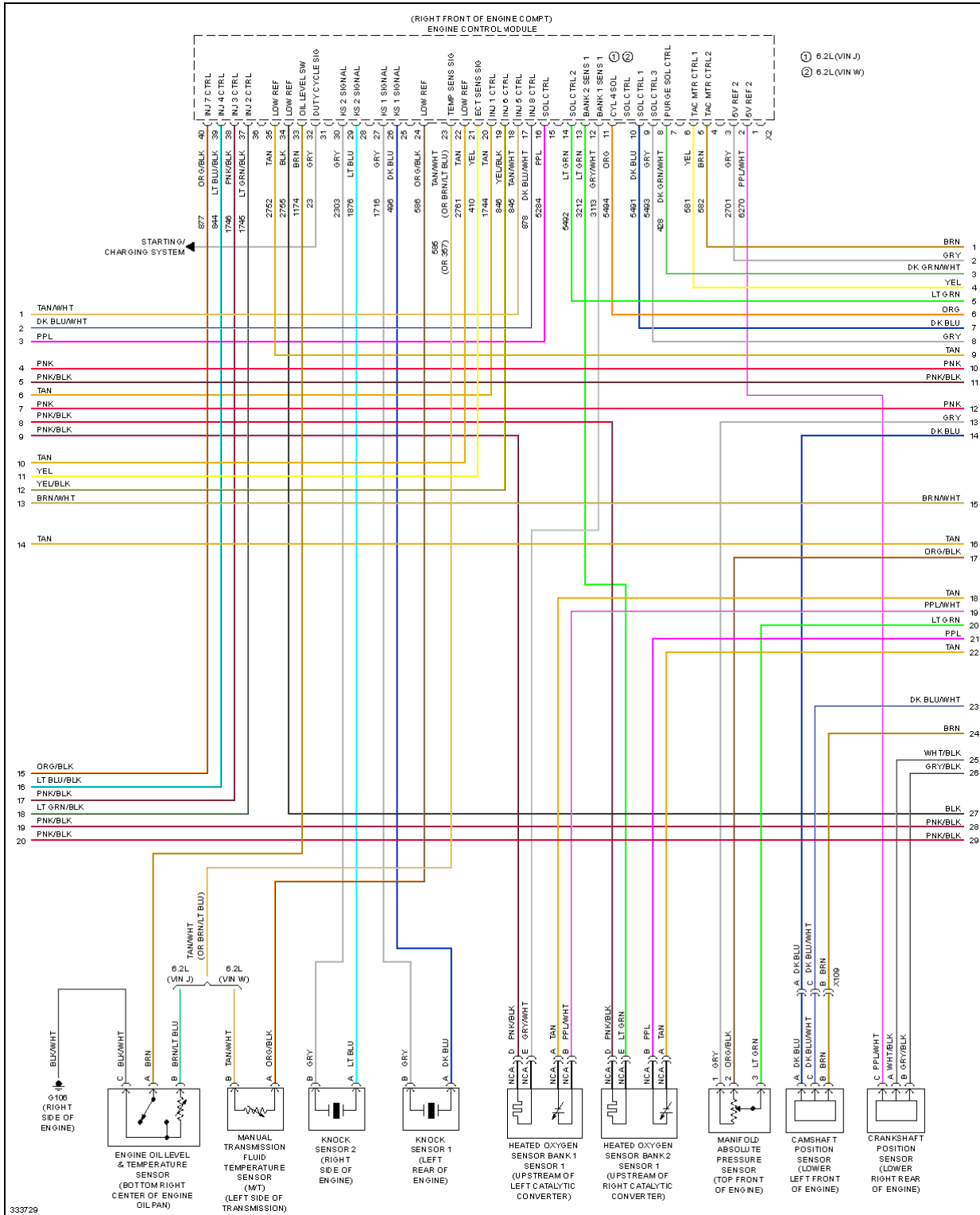

2010 Chevrolet Camaro LS

2010 SYSTEM WIRING DIAGRAMS Chevrolet - Camaro

Fig. 23: 6.2L VIN J, Engine Performance Circuit (4 of 6)

2010 Chevrolet Camaro LS

2010 SYSTEM WIRING DIAGRAMS Chevrolet - Camaro

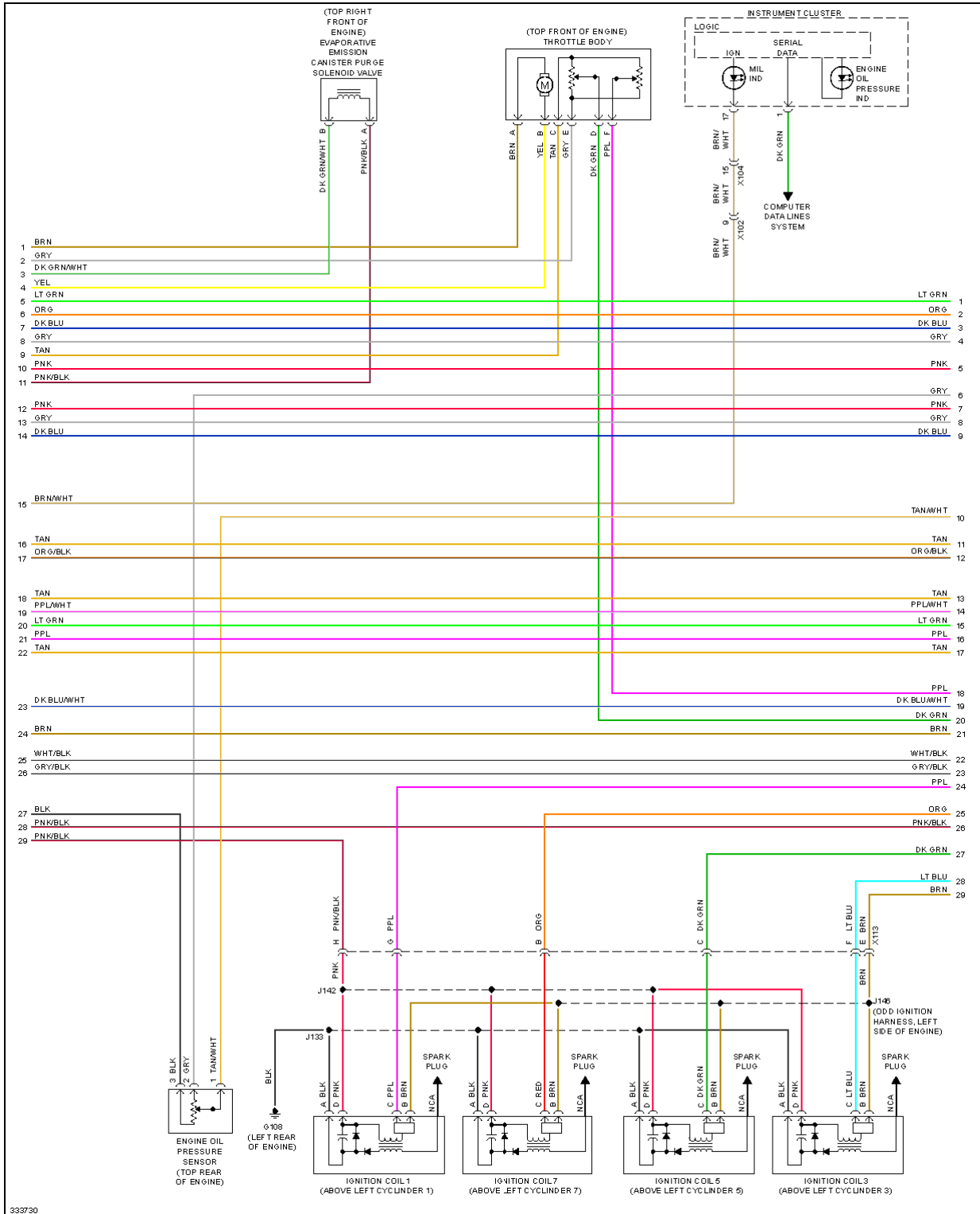

2010 Chevrolet Camaro LS

2010 SYSTEM WIRING DIAGRAMS Chevrolet - Camaro

Fig. 24: 6.2L VIN J, Engine Performance Circuit (5 of 6)

2010 Chevrolet Camaro LS

2010 SYSTEM WIRING DIAGRAMS Chevrolet - Camaro

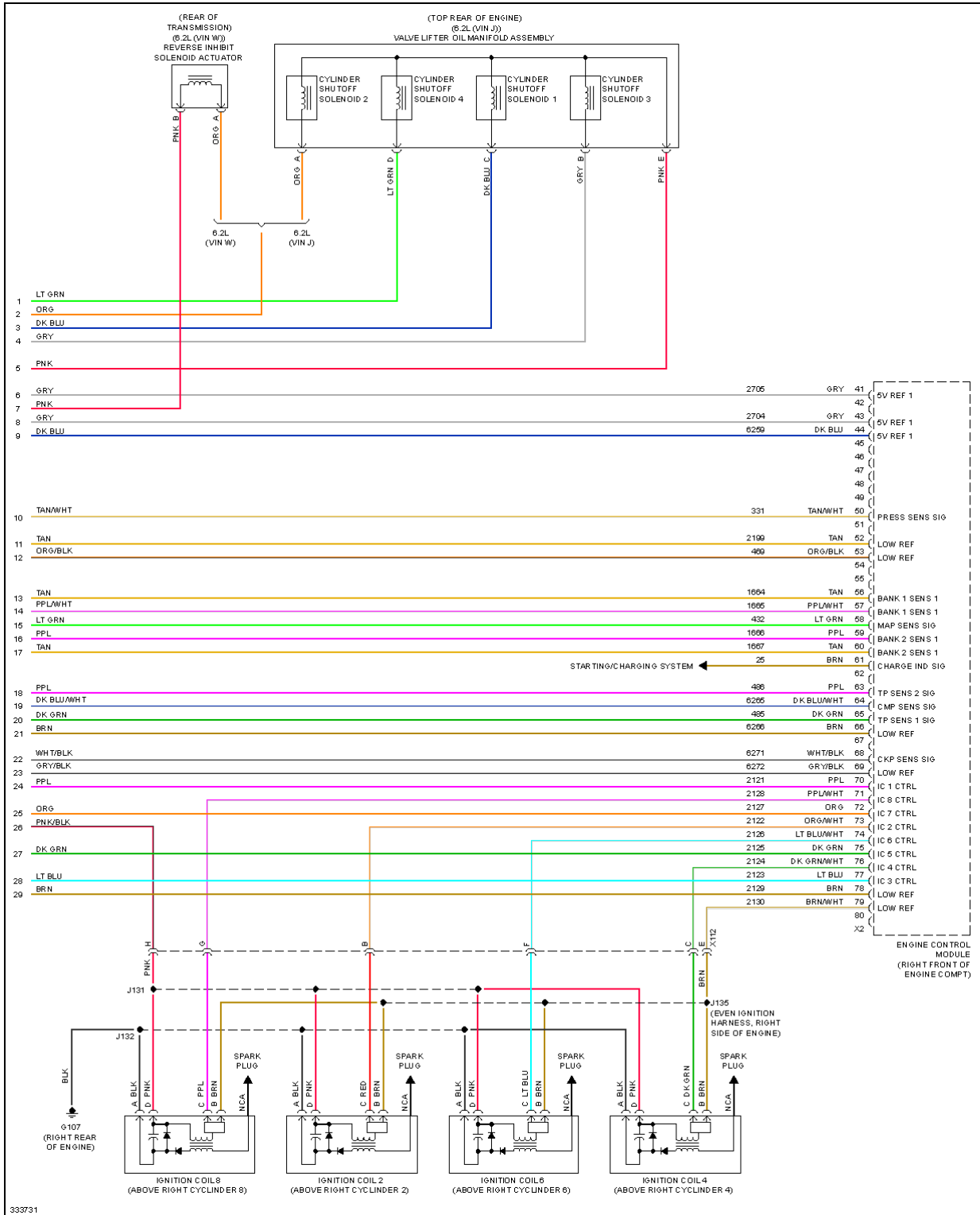

Fig. 25: 6.2L VIN J, Engine Performance Circuit (6 of 6)

6.2L VIN W

2010 Chevrolet Camaro LS

2010 SYSTEM WIRING DIAGRAMS Chevrolet - Camaro

Fig. 26: 6.2L VIN W, Engine Performance Circuit (1 of 6)

2010 Chevrolet Camaro LS

2010 SYSTEM WIRING DIAGRAMS Chevrolet - Camaro

Fig. 27: 6.2L VIN W, Engine Performance Circuit (2 of 6)

2010 Chevrolet Camaro LS

2010 SYSTEM WIRING DIAGRAMS Chevrolet - Camaro

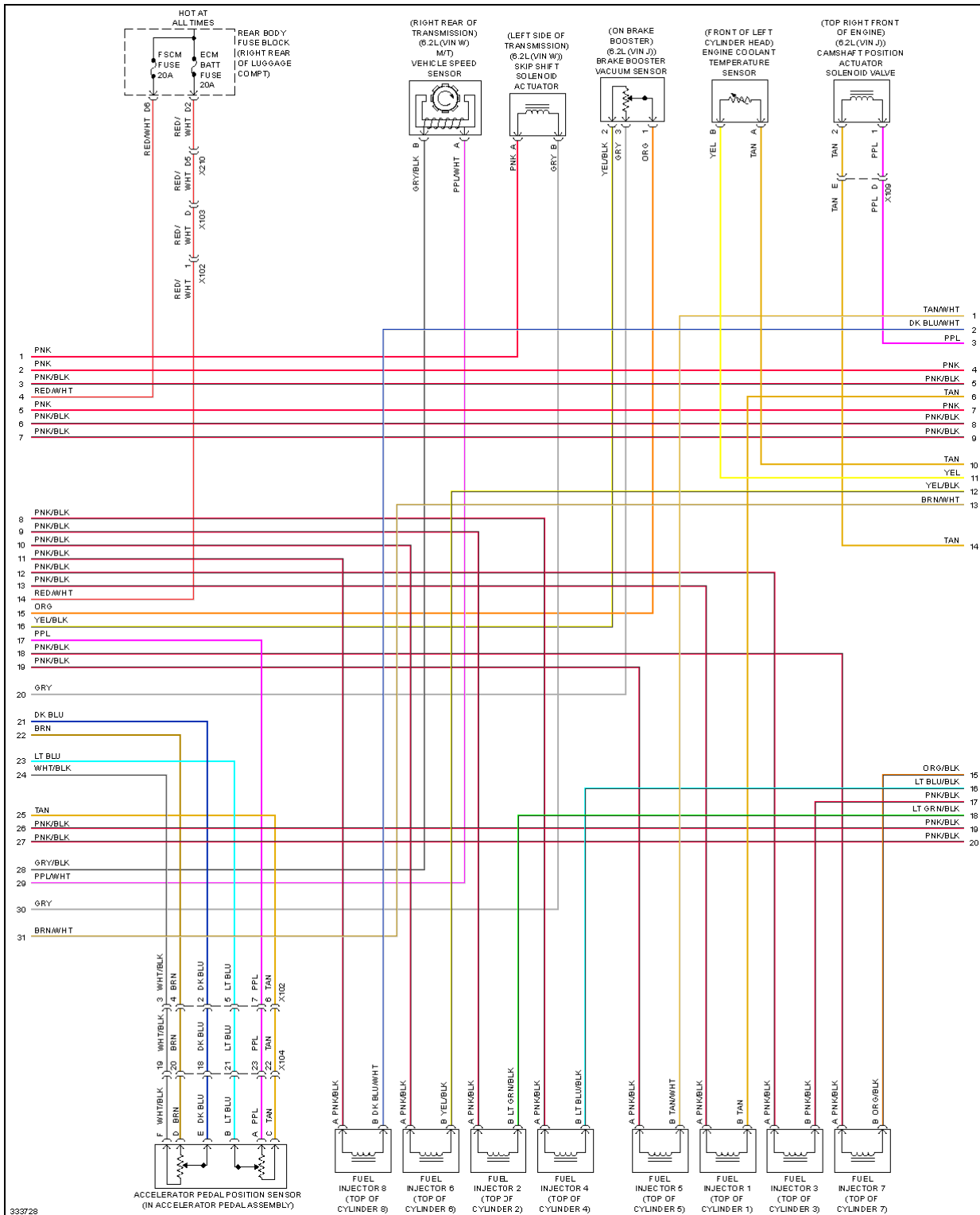

2010 Chevrolet Camaro LS

2010 SYSTEM WIRING DIAGRAMS Chevrolet - Camaro

Fig. 28: 6.2L VIN W, Engine Performance Circuit (3 of 6)

2010 Chevrolet Camaro LS

2010 SYSTEM WIRING DIAGRAMS Chevrolet - Camaro

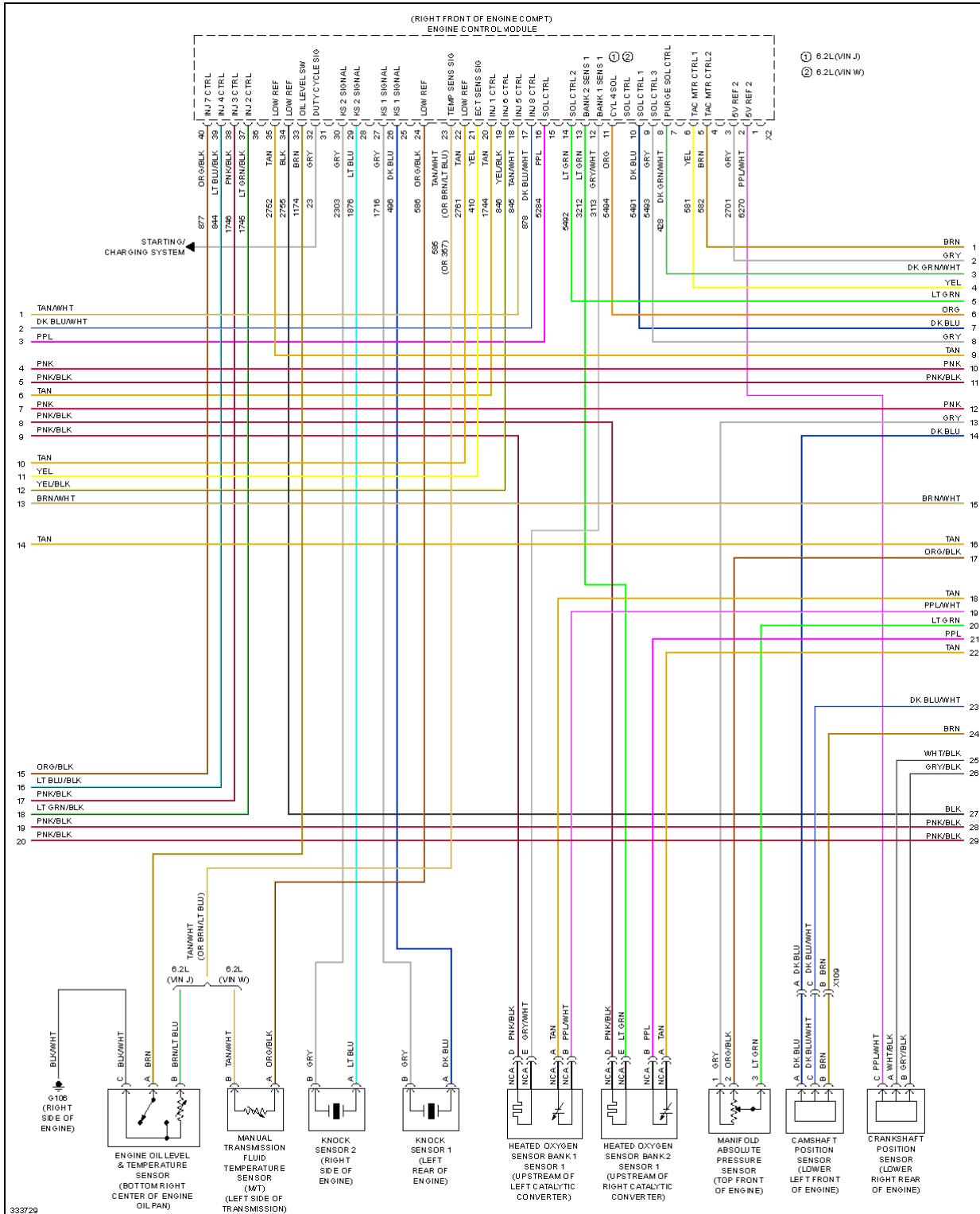

2010 Chevrolet Camaro LS

2010 SYSTEM WIRING DIAGRAMS Chevrolet - Camaro

Fig. 29: 6.2L VIN W, Engine Performance Circuit (4 of 6)

2010 Chevrolet Camaro LS

2010 SYSTEM WIRING DIAGRAMS Chevrolet - Camaro

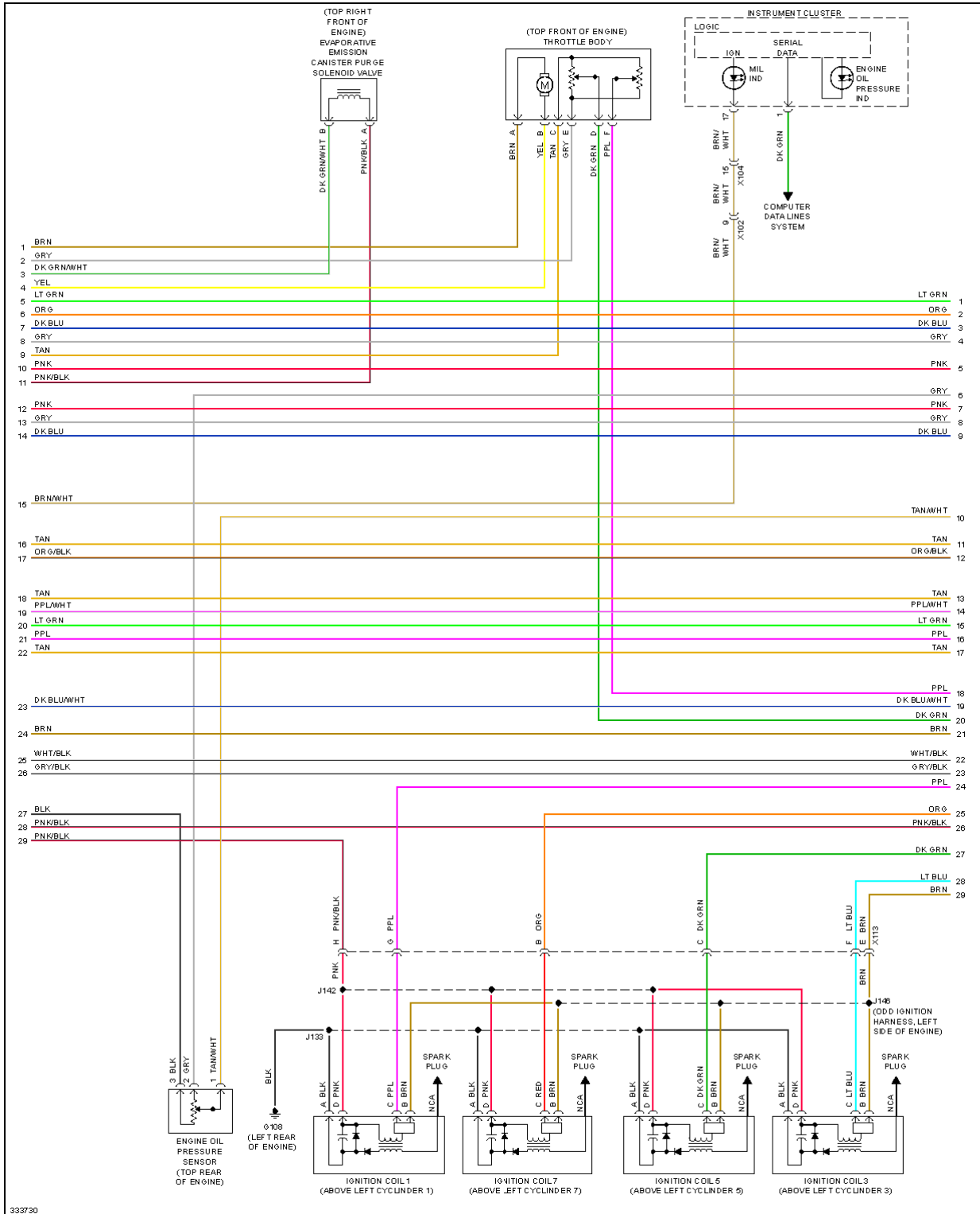

2010 Chevrolet Camaro LS

2010 SYSTEM WIRING DIAGRAMS Chevrolet - Camaro

Fig. 30: 6.2L VIN W, Engine Performance Circuit (5 of 6)

2010 Chevrolet Camaro LS

2010 SYSTEM WIRING DIAGRAMS Chevrolet - Camaro

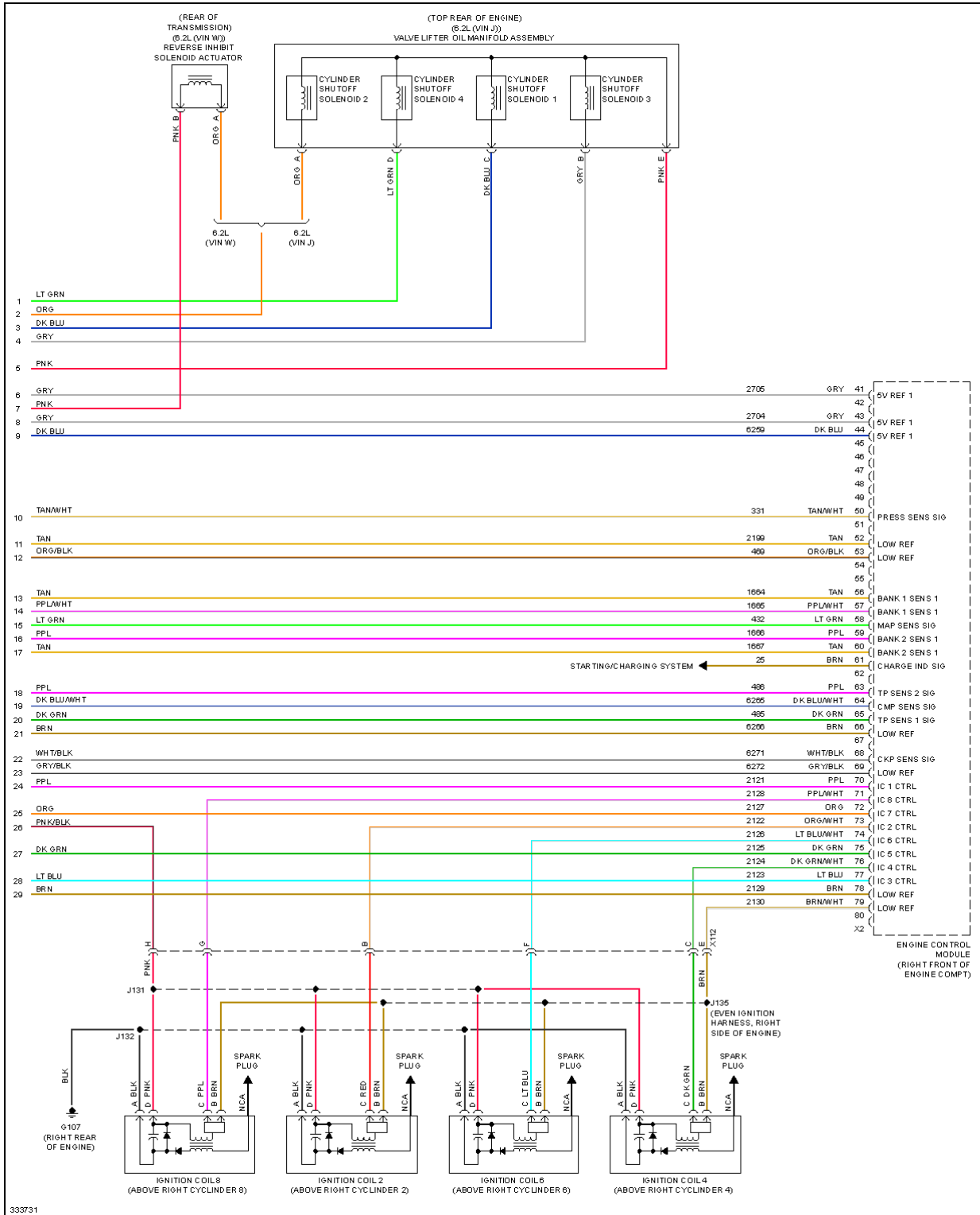
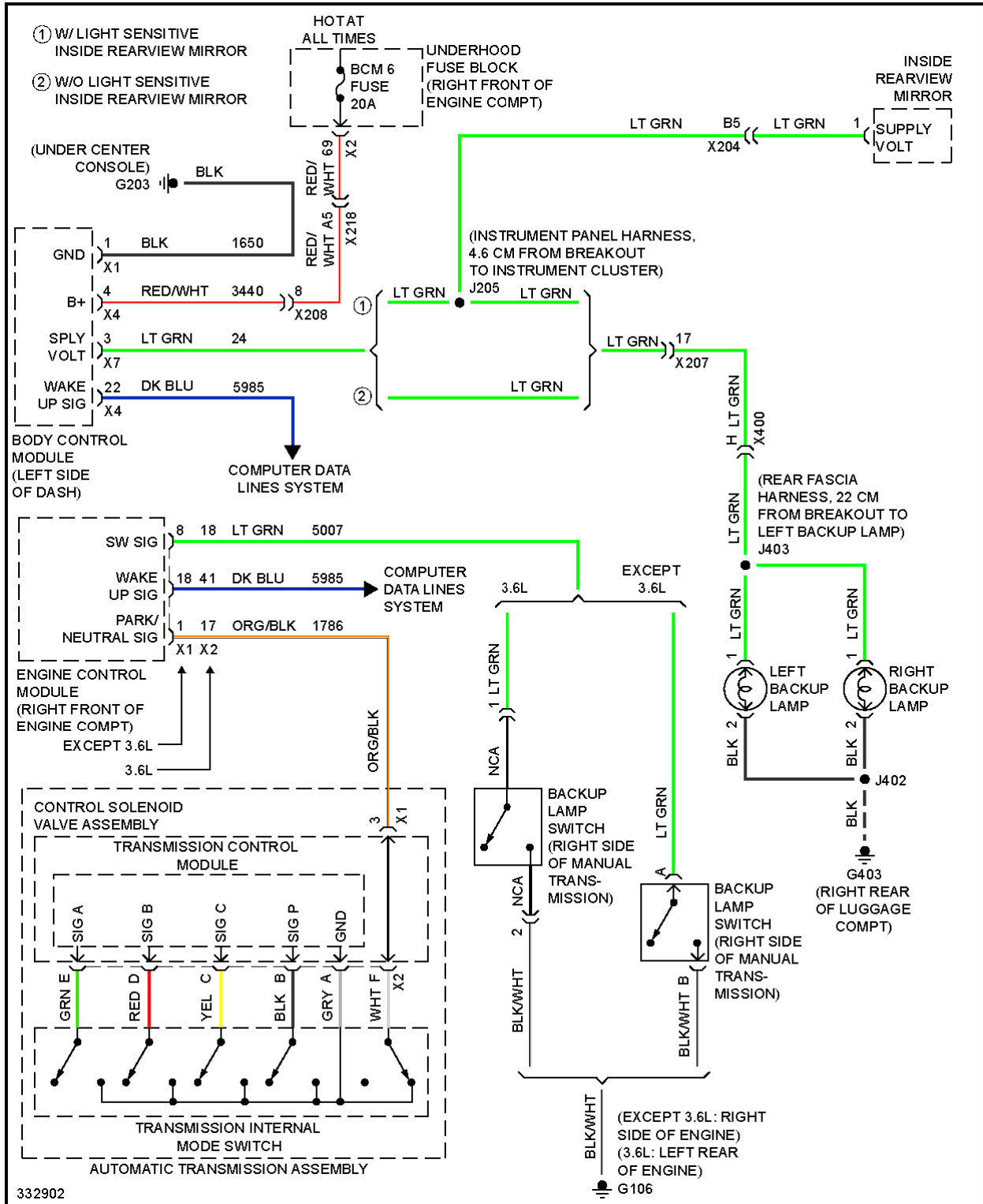

Fig. 31: 6.2L VIN W, Engine Performance Circuit (6 of 6)

EXTERIOR LIGHTS

2010 Chevrolet Camaro LS

2010 SYSTEM WIRING DIAGRAMS Chevrolet - Camaro



2010 Chevrolet Camaro LS

2010 SYSTEM WIRING DIAGRAMS Chevrolet - Camaro

Fig. 32: Backup Lamps Circuit

2010 Chevrolet Camaro LS

2010 SYSTEM WIRING DIAGRAMS Chevrolet - Camaro

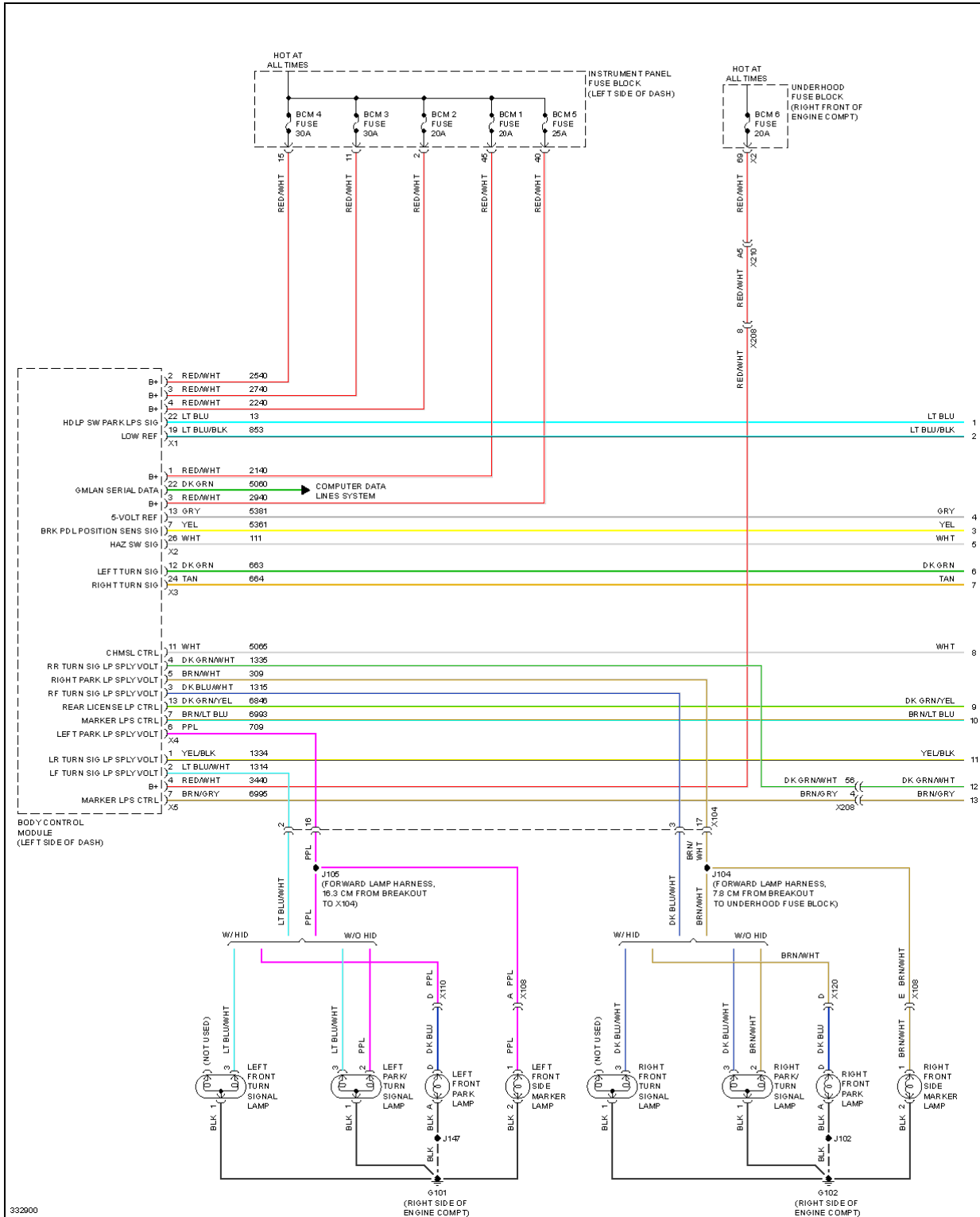

2010 Chevrolet Camaro LS

2010 SYSTEM WIRING DIAGRAMS Chevrolet - Camaro

Fig. 33: Exterior Lamps Circuit (1 of 2)

2010 Chevrolet Camaro LS

2010 SYSTEM WIRING DIAGRAMS Chevrolet - Camaro

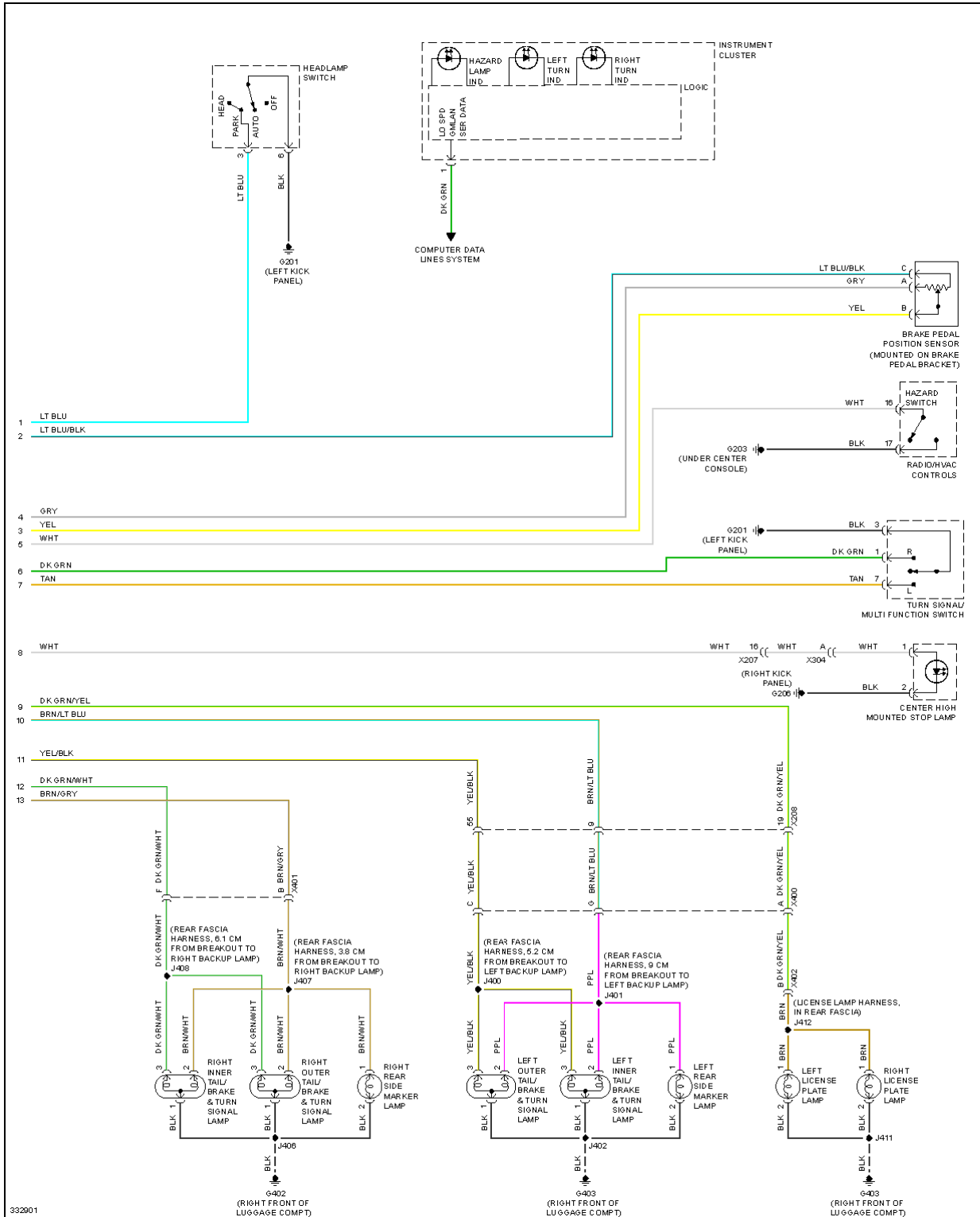
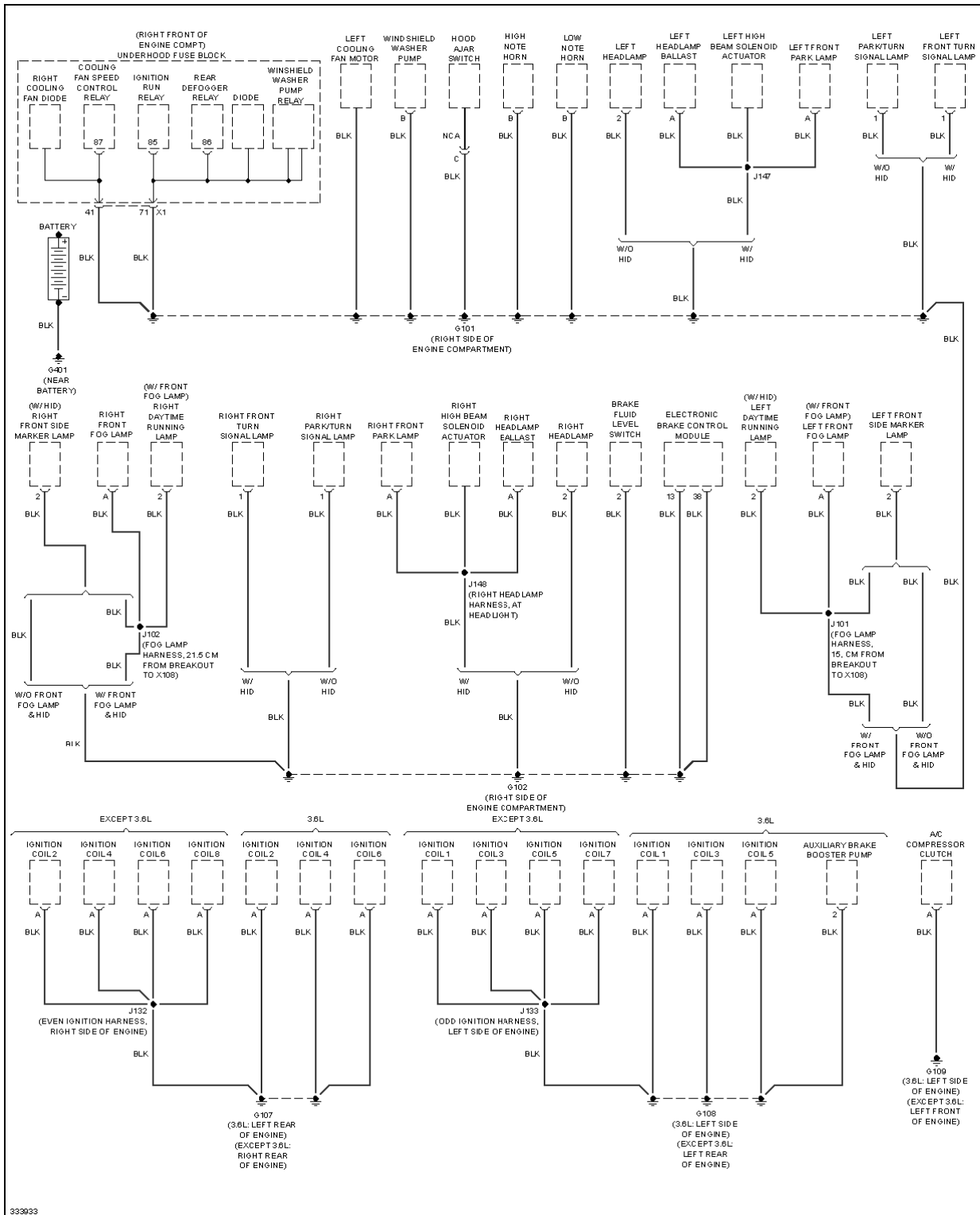

Fig. 34: Exterior Lamps Circuit (2 of 2)

GROUND DISTRIBUTION

2010 Chevrolet Camaro LS

2010 SYSTEM WIRING DIAGRAMS Chevrolet - Camaro



2010 Chevrolet Camaro LS

2010 SYSTEM WIRING DIAGRAMS Chevrolet - Camaro

Fig. 35: Ground Distribution Circuit (1 of 3)

2010 Chevrolet Camaro LS

2010 SYSTEM WIRING DIAGRAMS Chevrolet - Camaro

Fig. 36: Ground Distribution Circuit (2 of 3)

2010 Chevrolet Camaro LS

2010 SYSTEM WIRING DIAGRAMS Chevrolet - Camaro

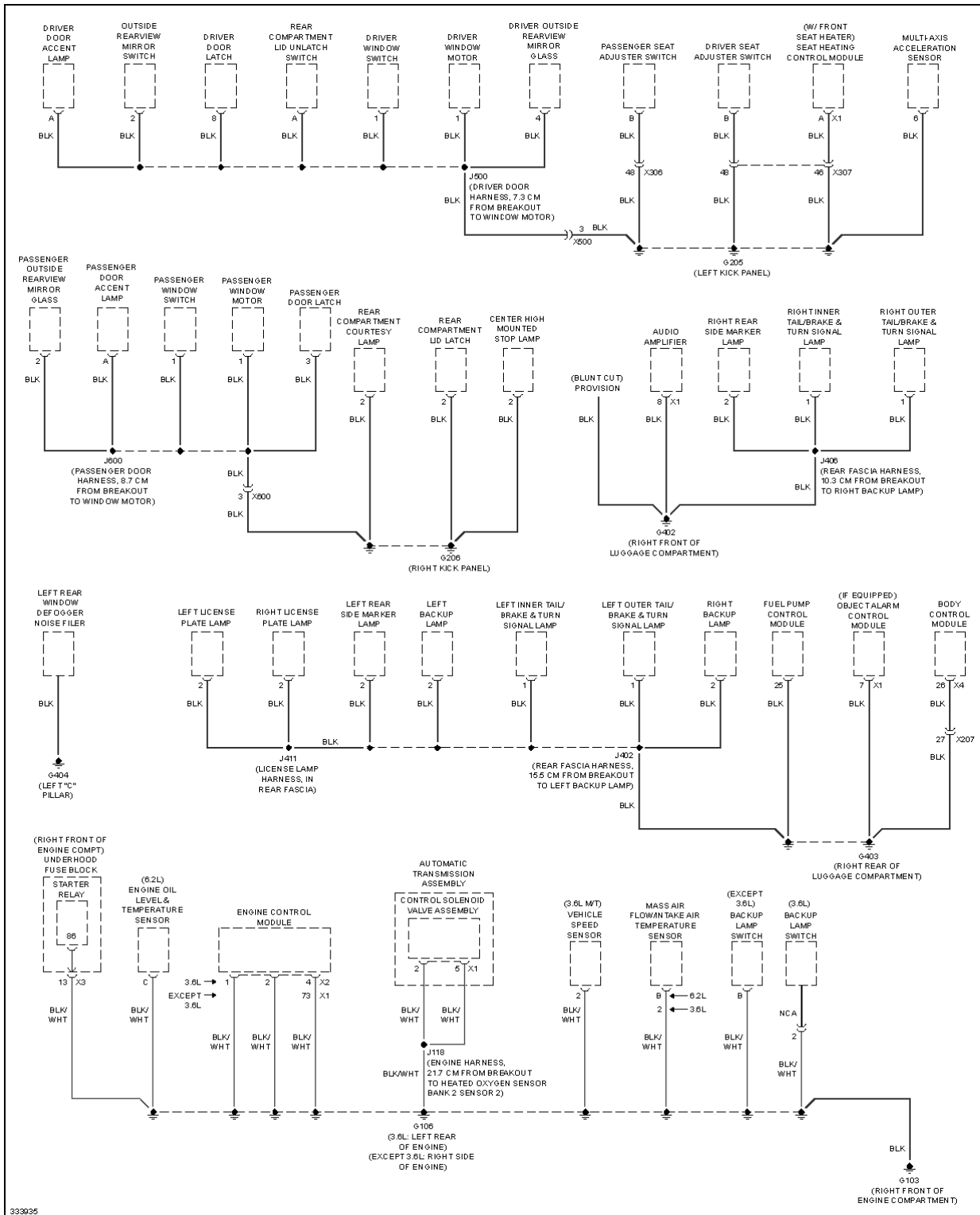
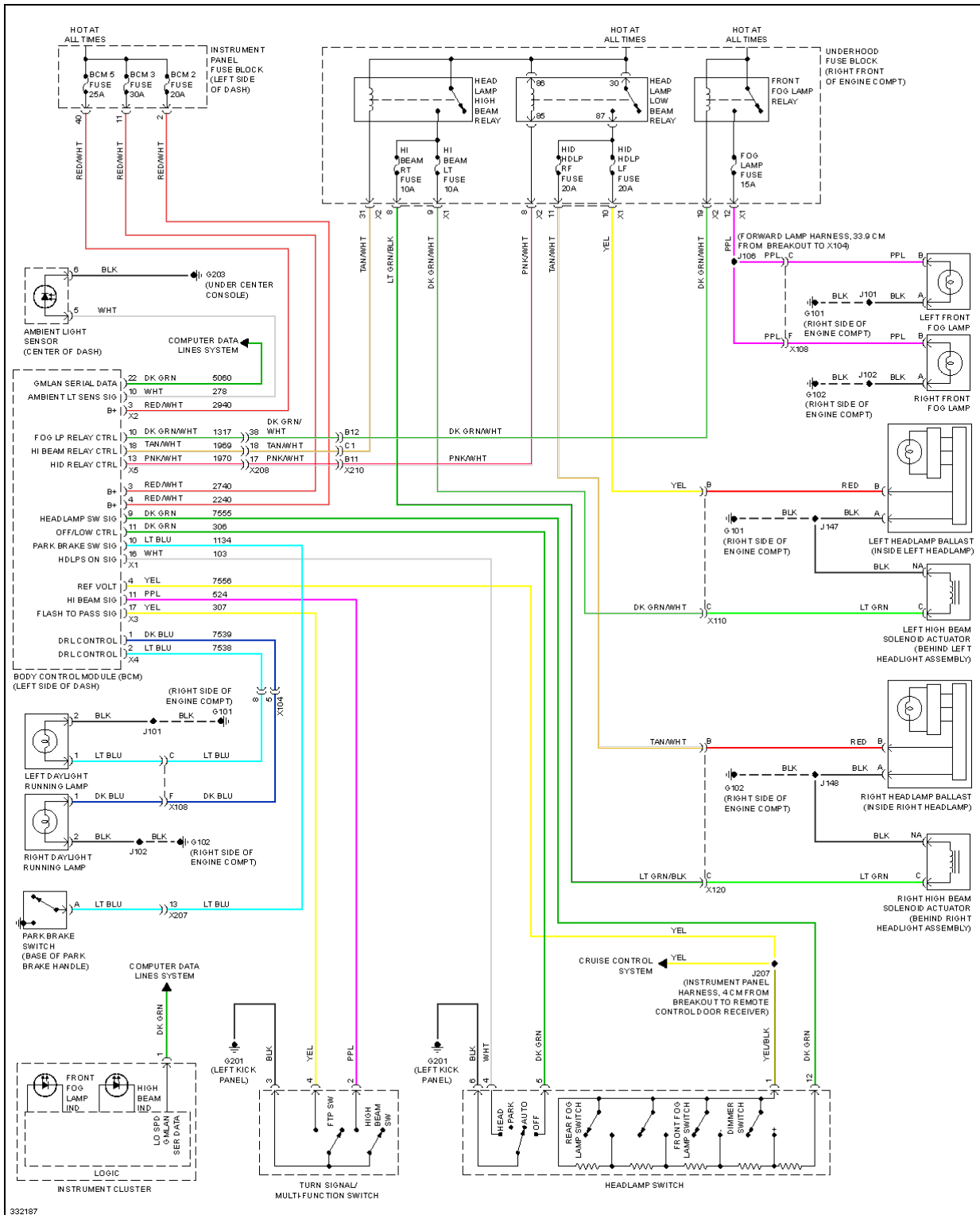

Fig. 37: Ground Distribution Circuit (3 of 3)

HEADLIGHTS

2010 Chevrolet Camaro LS

2010 SYSTEM WIRING DIAGRAMS Chevrolet - Camaro



2010 Chevrolet Camaro LS

2010 SYSTEM WIRING DIAGRAMS Chevrolet - Camaro

Fig. 38: Headlights Circuit, W/ High Intensity Discharge

2010 Chevrolet Camaro LS

2010 SYSTEM WIRING DIAGRAMS Chevrolet - Camaro

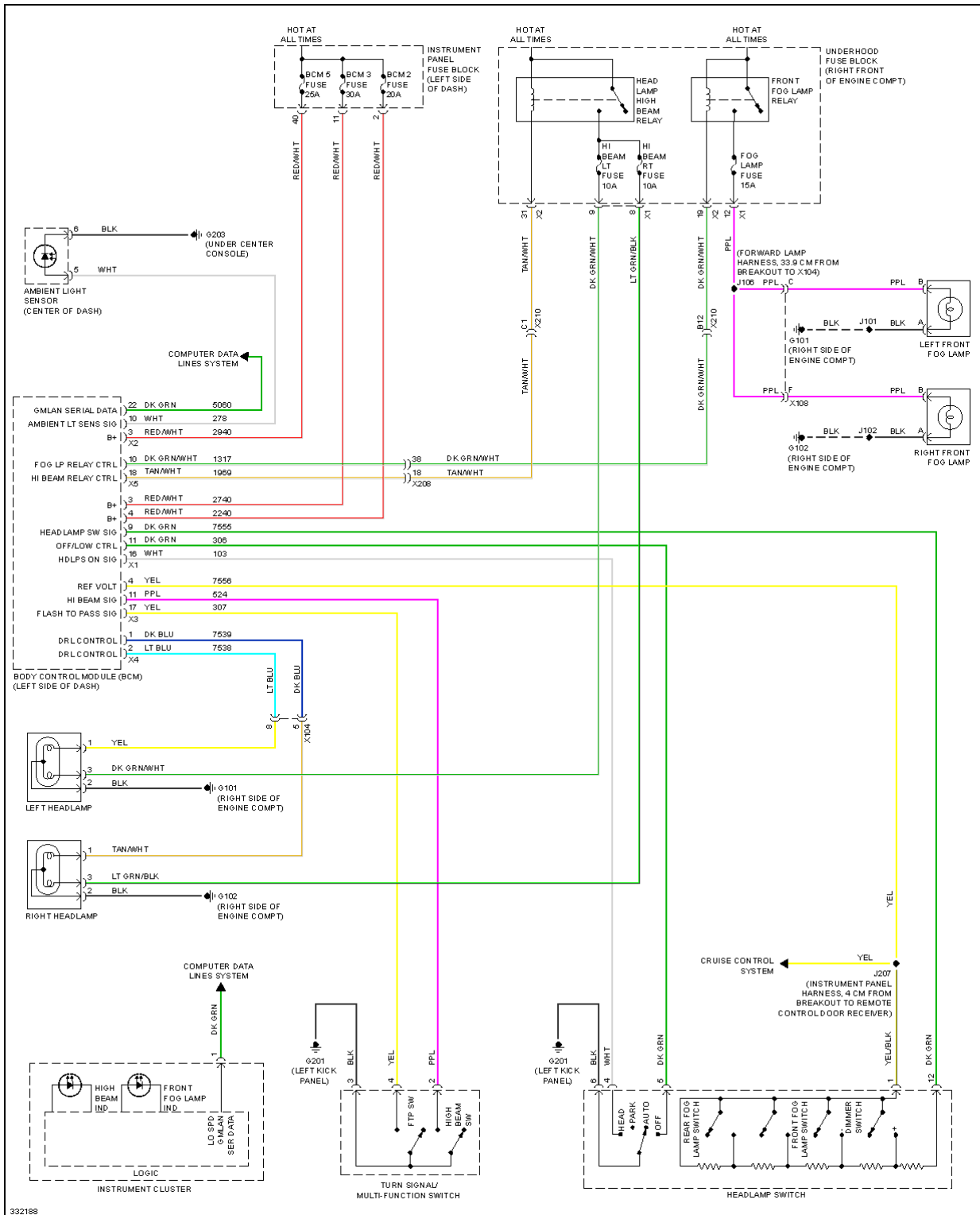

Fig. 39: Headlights Circuit, W/O High Intensity Discharge

HORN

2010 Chevrolet Camaro LS

2010 SYSTEM WIRING DIAGRAMS Chevrolet - Camaro

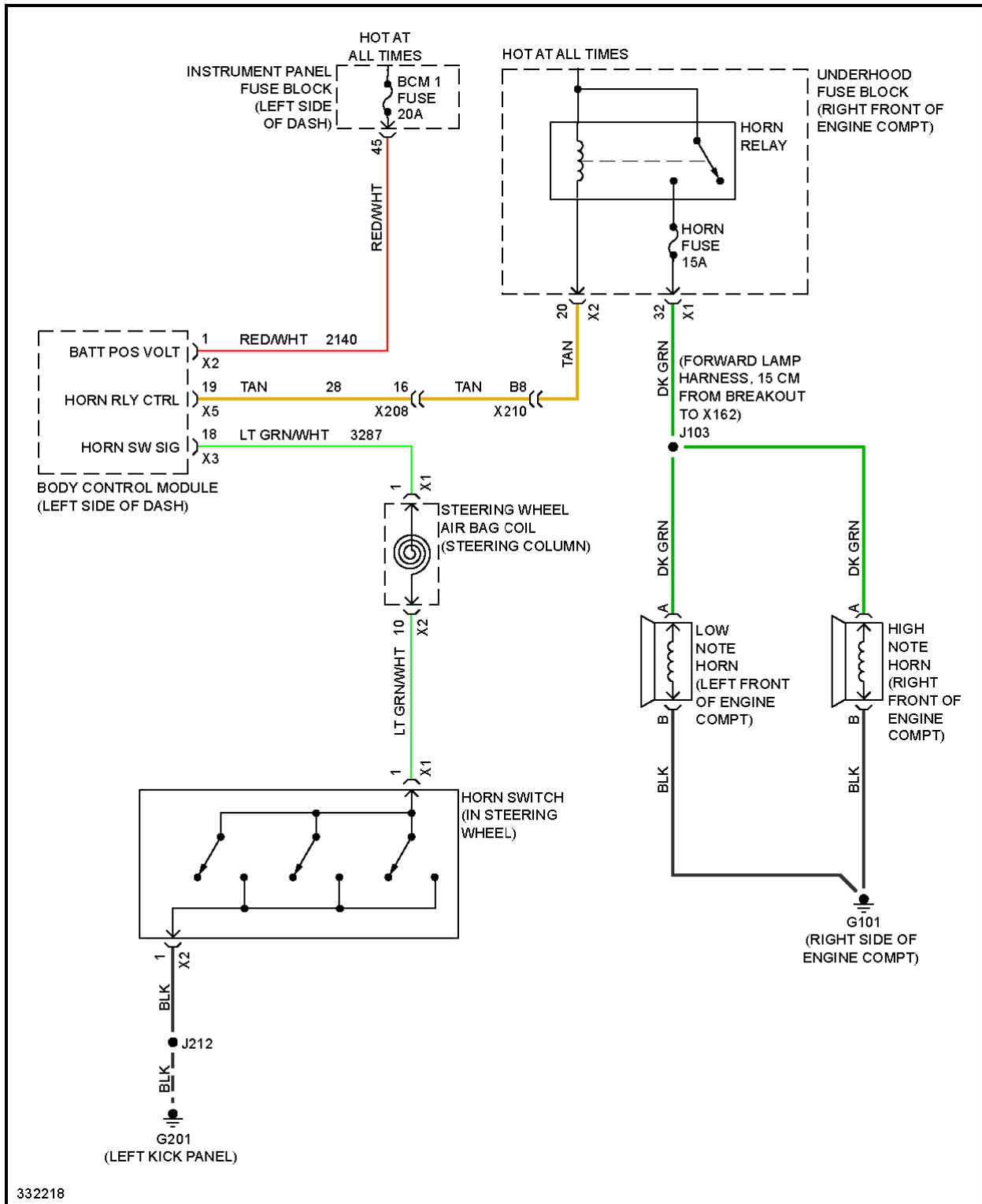
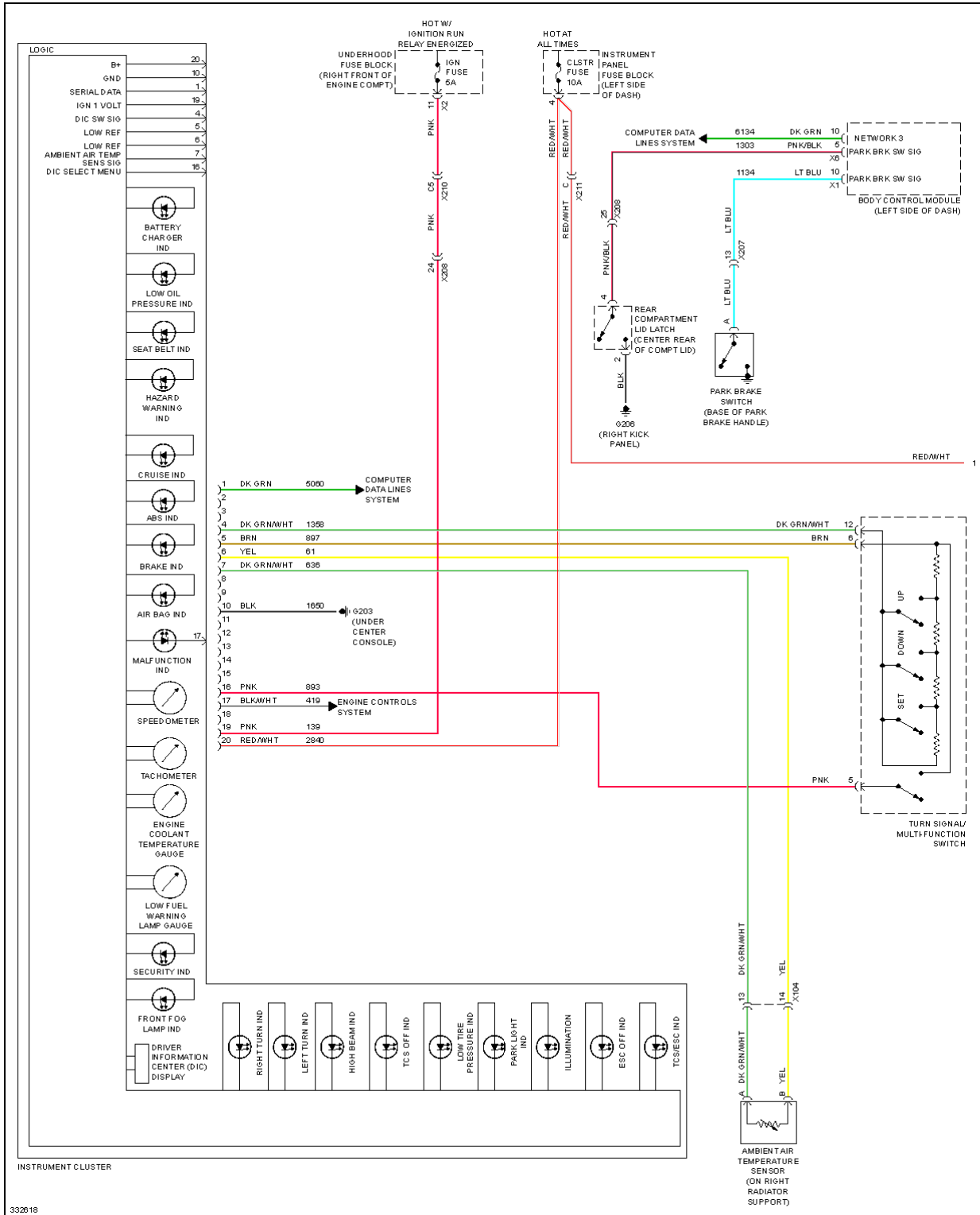

Fig. 40: Horn Circuit

INSTRUMENT CLUSTER

2010 Chevrolet Camaro LS

2010 SYSTEM WIRING DIAGRAMS Chevrolet - Camaro



2010 Chevrolet Camaro LS

2010 SYSTEM WIRING DIAGRAMS Chevrolet - Camaro

Fig. 41: Instrument Cluster Circuit (1 of 2)

2010 Chevrolet Camaro LS

2010 SYSTEM WIRING DIAGRAMS Chevrolet - Camaro

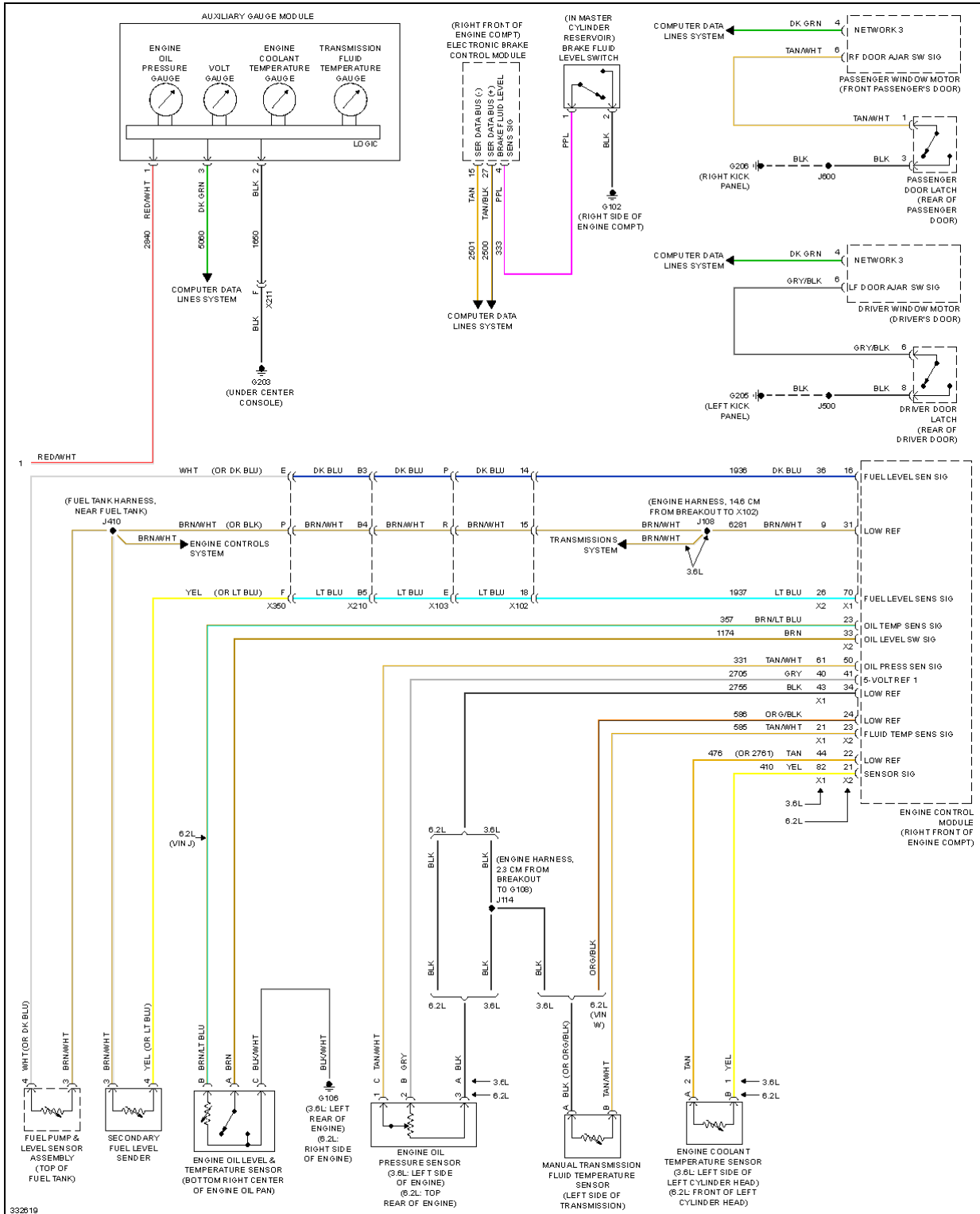
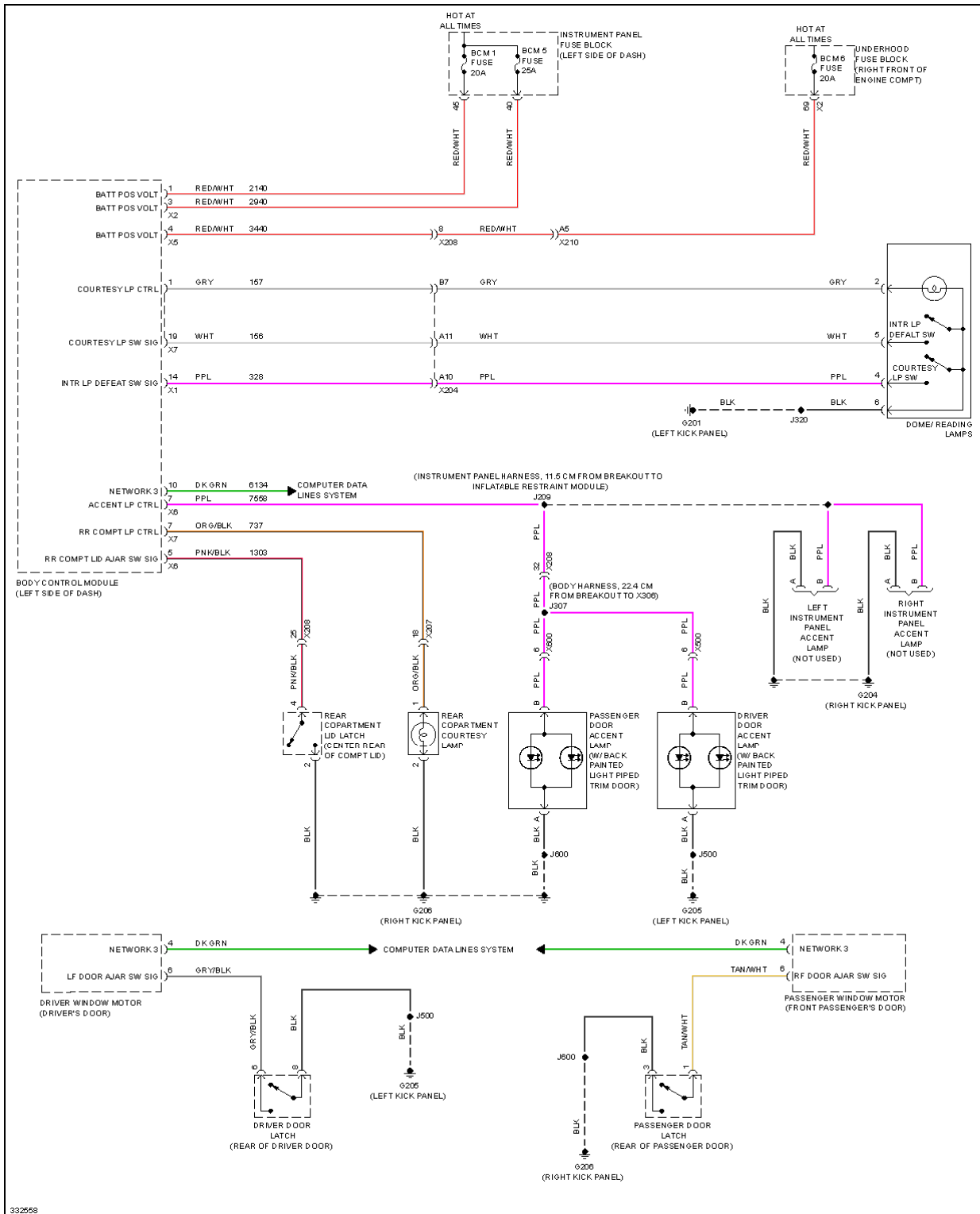

Fig. 42: Instrument Cluster Circuit (2 of 2)

INTERIOR LIGHTS

2010 Chevrolet Camaro LS

2010 SYSTEM WIRING DIAGRAMS Chevrolet - Camaro



2010 Chevrolet Camaro LS

2010 SYSTEM WIRING DIAGRAMS Chevrolet - Camaro

Fig. 43: Courtesy Lamps Circuit

2010 Chevrolet Camaro LS

2010 SYSTEM WIRING DIAGRAMS Chevrolet - Camaro

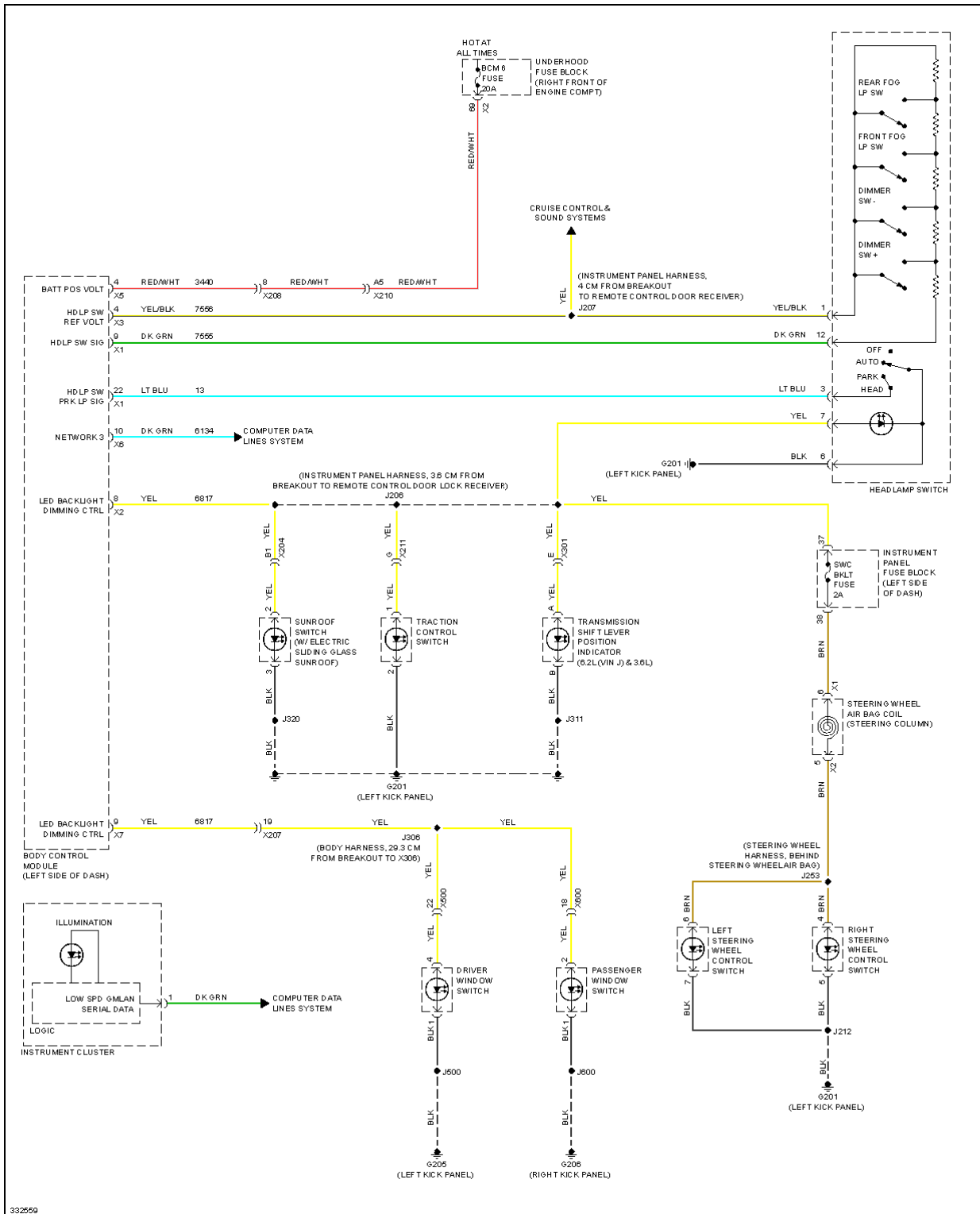

Fig. 44: Instrument Illumination Circuit

NAVIGATION

2010 Chevrolet Camaro LS

2010 SYSTEM WIRING DIAGRAMS Chevrolet - Camaro

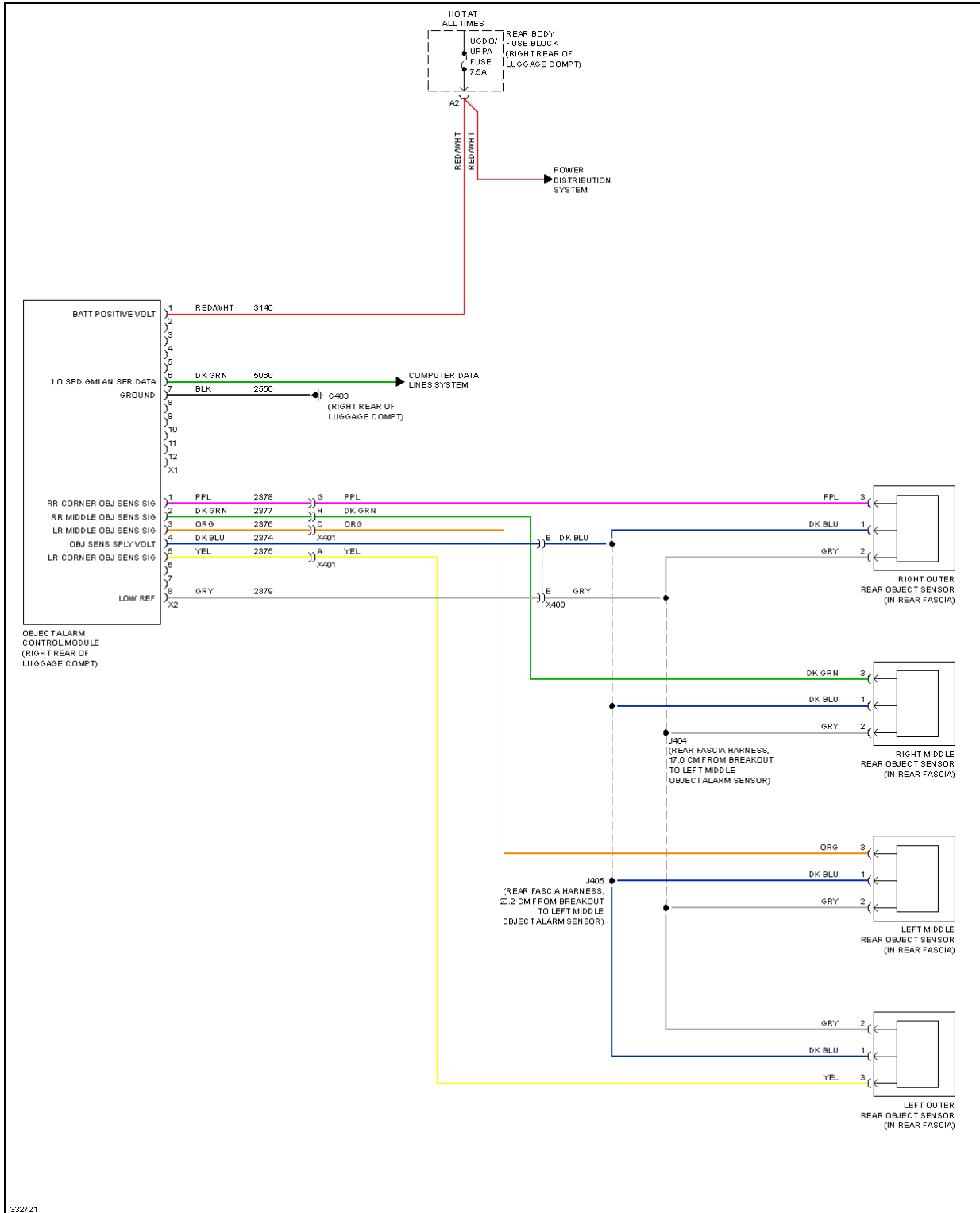
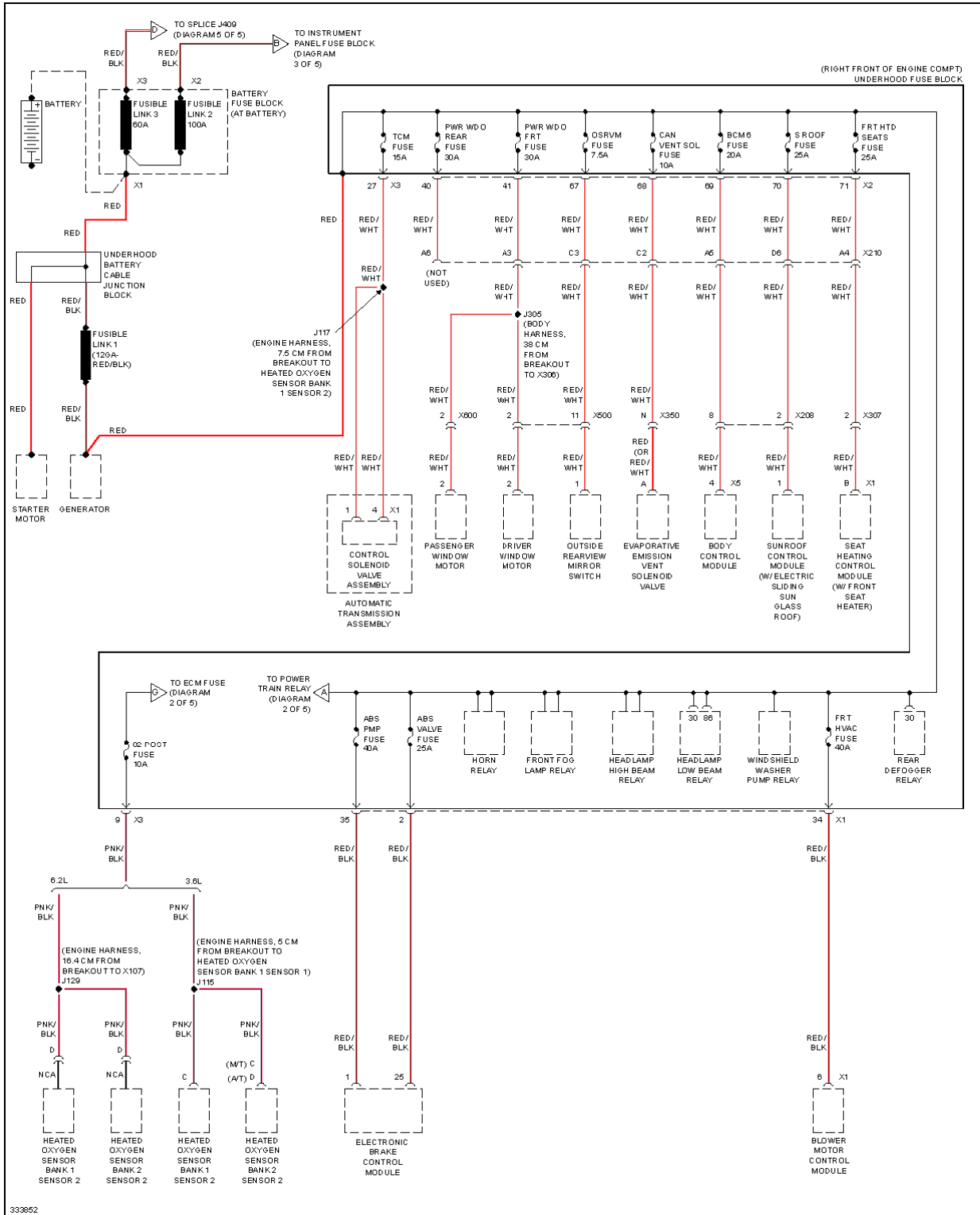

Fig. 45: Parking Assistant Circuit

POWER DISTRIBUTION

2010 Chevrolet Camaro LS

2010 SYSTEM WIRING DIAGRAMS Chevrolet - Camaro



2010 Chevrolet Camaro LS

2010 SYSTEM WIRING DIAGRAMS Chevrolet - Camaro

Fig. 46: Power Distribution Circuit (1 of 5)

2010 Chevrolet Camaro LS

2010 SYSTEM WIRING DIAGRAMS Chevrolet - Camaro

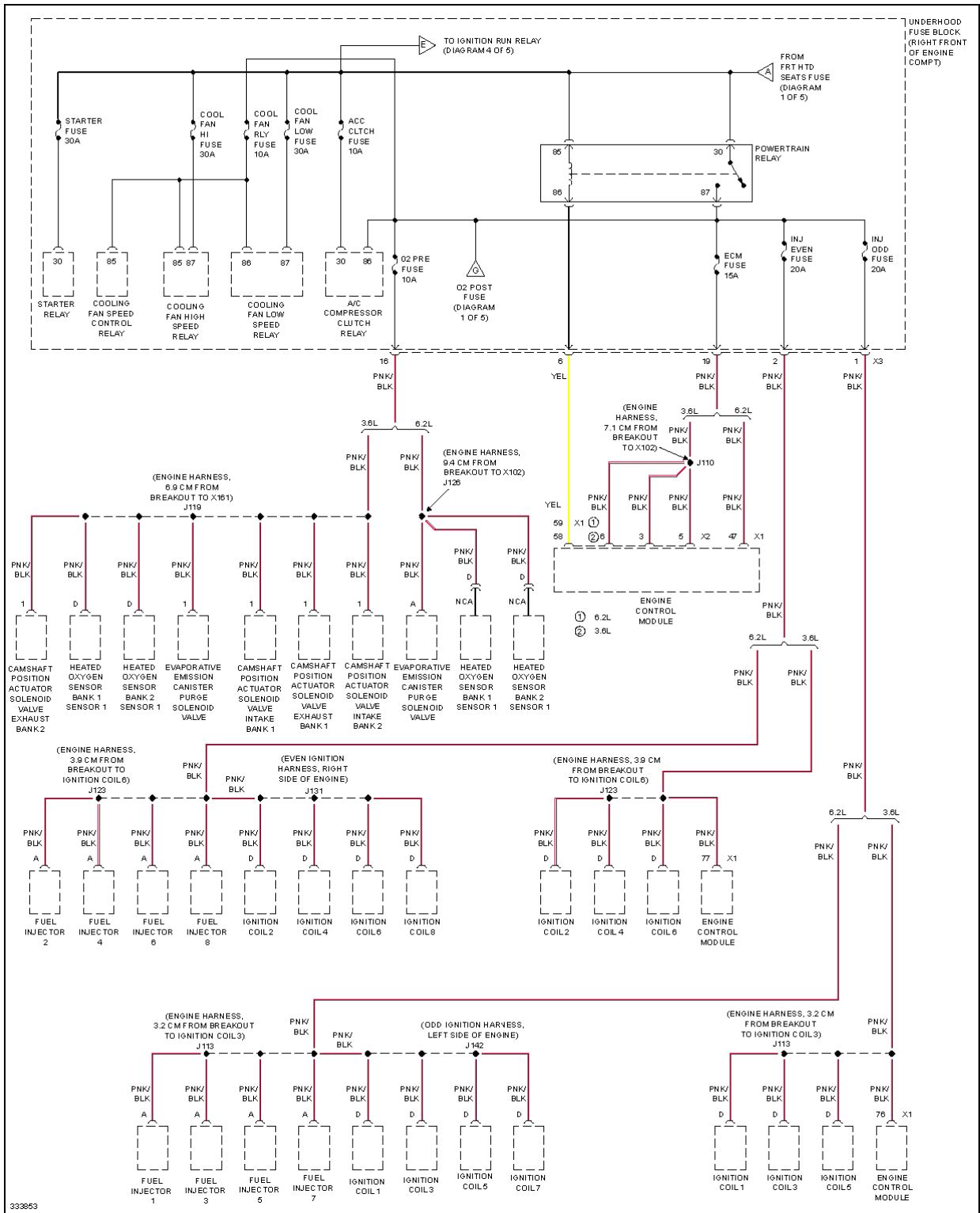

2010 Chevrolet Camaro LS

2010 SYSTEM WIRING DIAGRAMS Chevrolet - Camaro

Fig. 47: Power Distribution Circuit (2 of 5)

2010 Chevrolet Camaro LS

2010 SYSTEM WIRING DIAGRAMS Chevrolet - Camaro

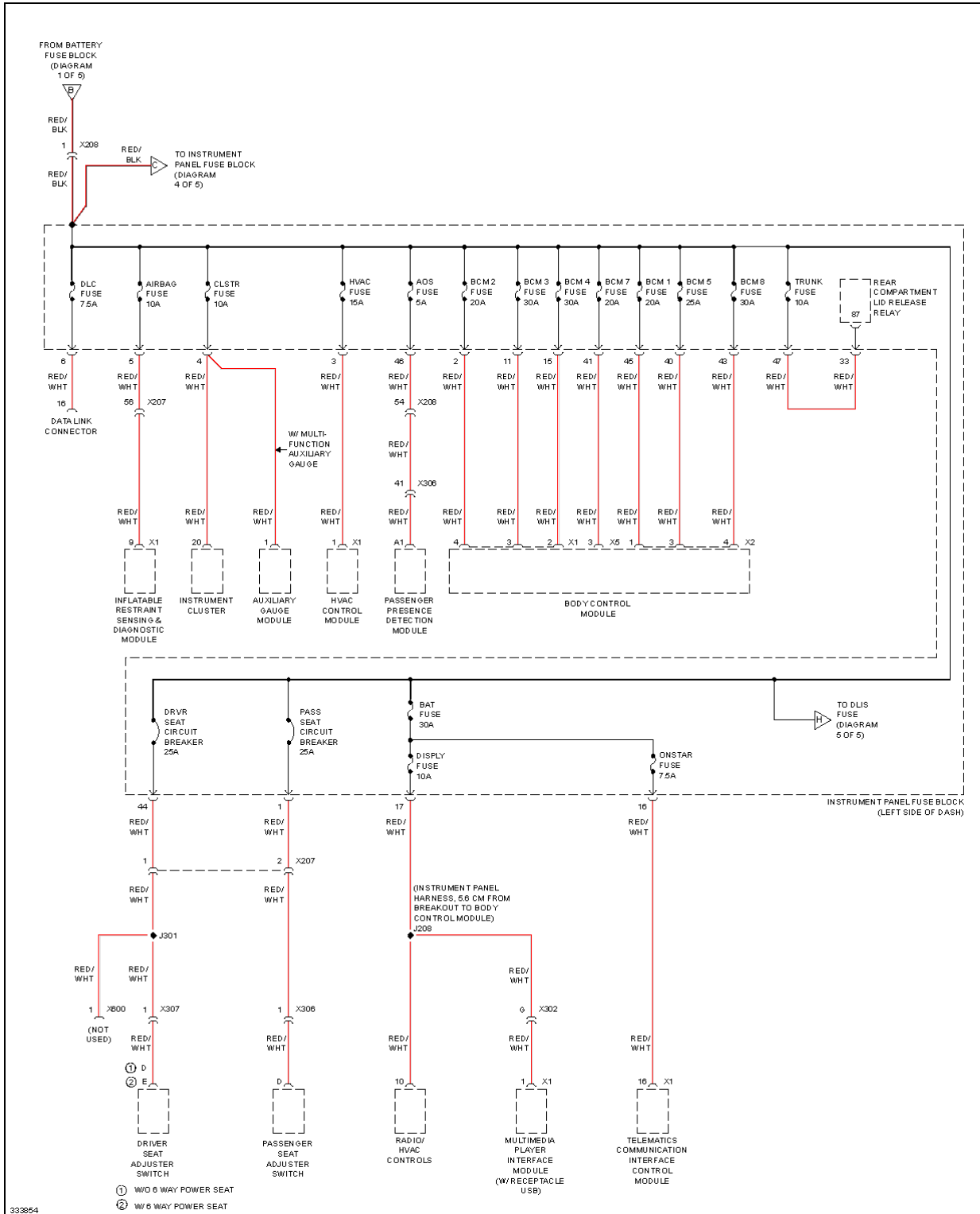

2010 Chevrolet Camaro LS

2010 SYSTEM WIRING DIAGRAMS Chevrolet - Camaro

Fig. 48: Power Distribution Circuit (3 of 5)

2010 Chevrolet Camaro LS

2010 SYSTEM WIRING DIAGRAMS Chevrolet - Camaro

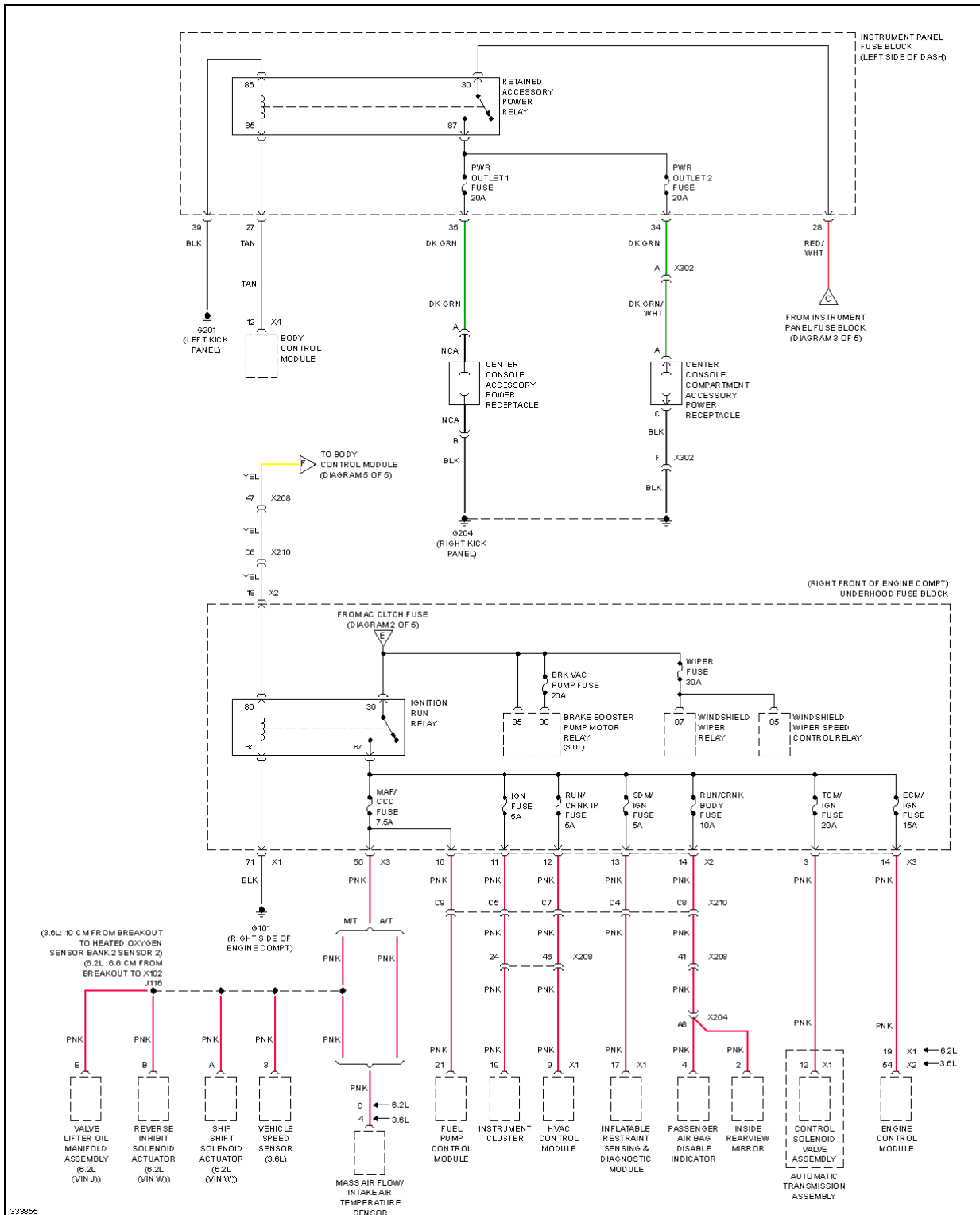

2010 Chevrolet Camaro LS

2010 SYSTEM WIRING DIAGRAMS Chevrolet - Camaro

Fig. 49: Power Distribution Circuit (4 of 5)

2010 Chevrolet Camaro LS

2010 SYSTEM WIRING DIAGRAMS Chevrolet - Camaro

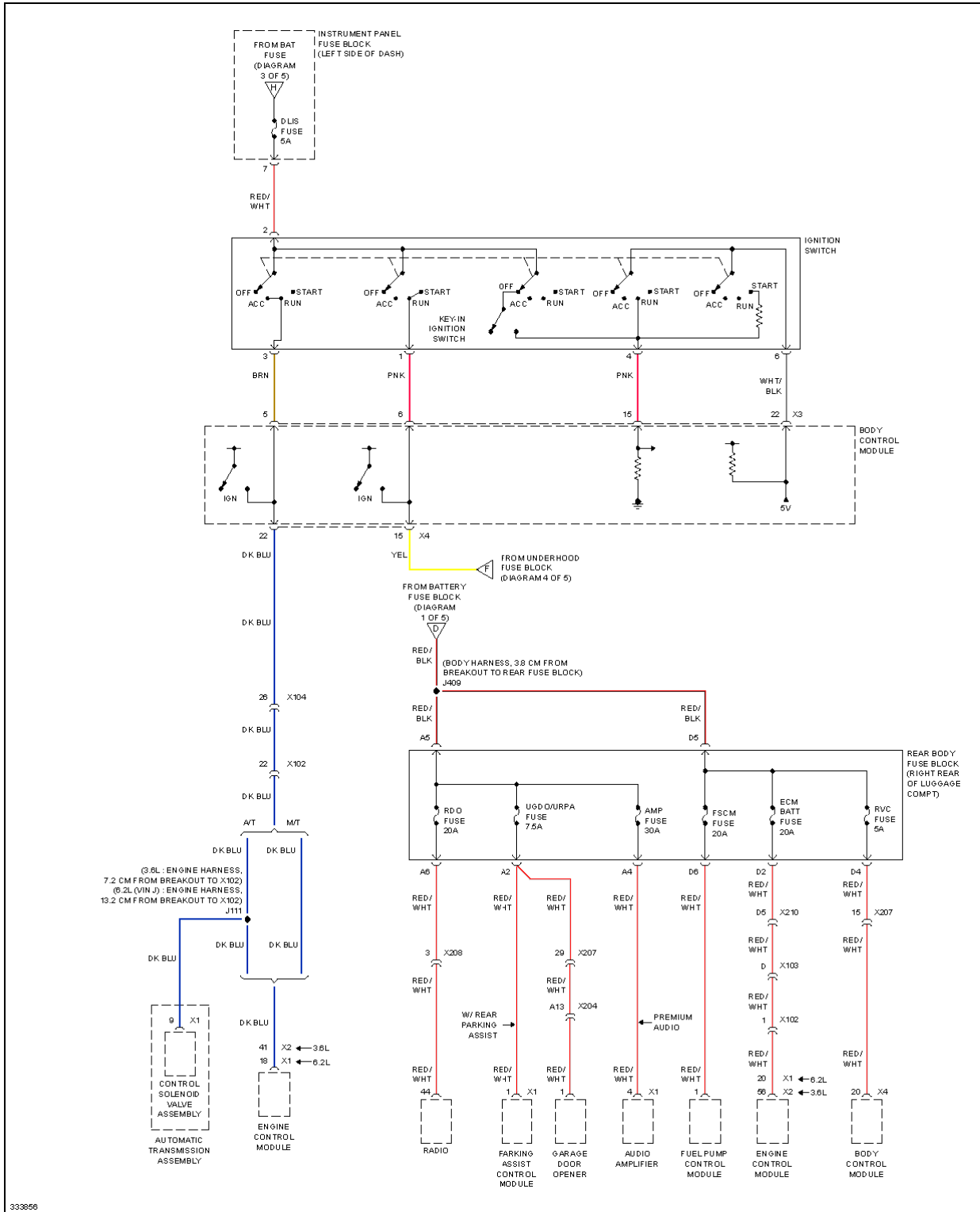

Fig. 50: Power Distribution Circuit (5 of 5)

POWER DOOR LOCKS

2010 Chevrolet Camaro LS

2010 SYSTEM WIRING DIAGRAMS Chevrolet - Camaro

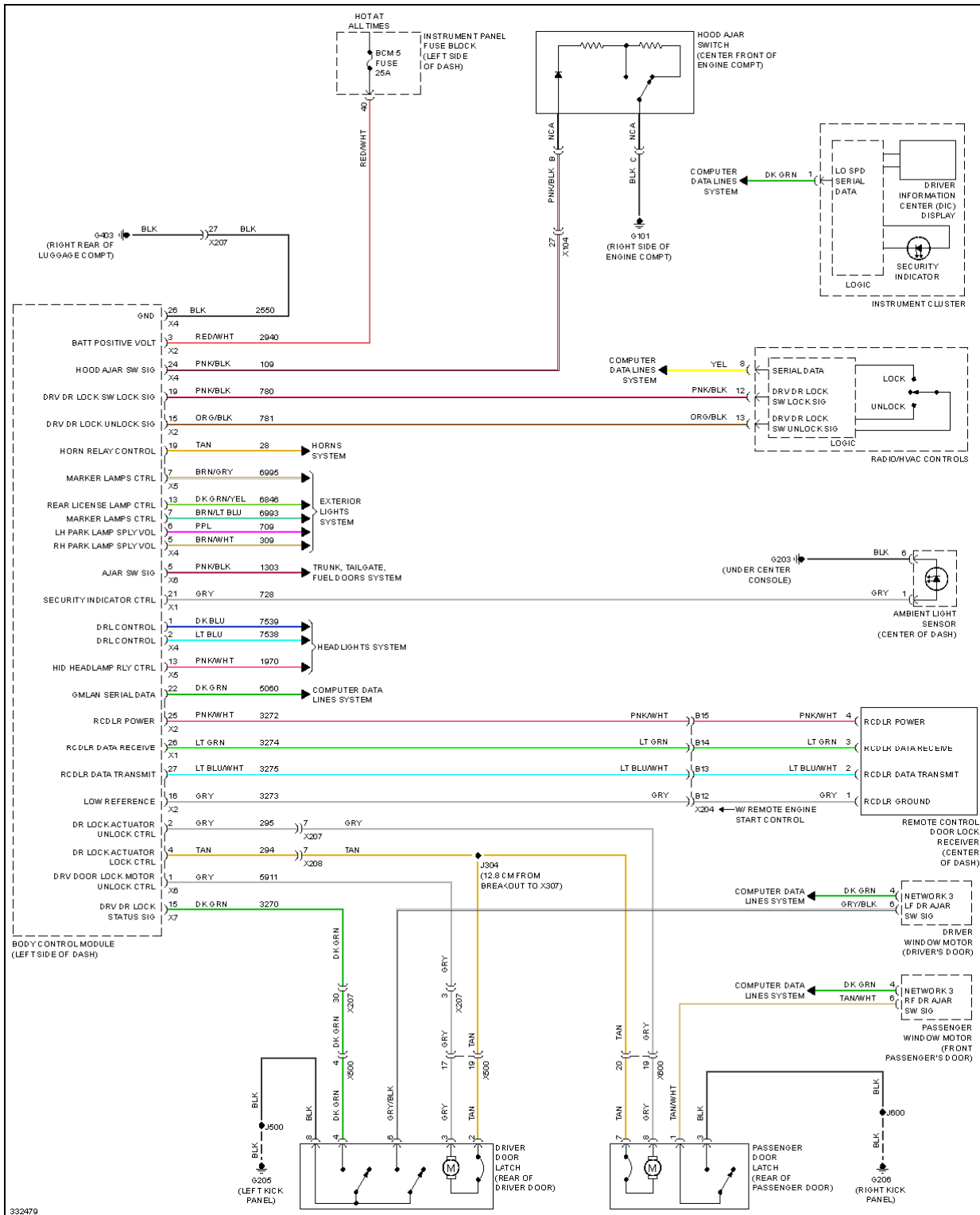
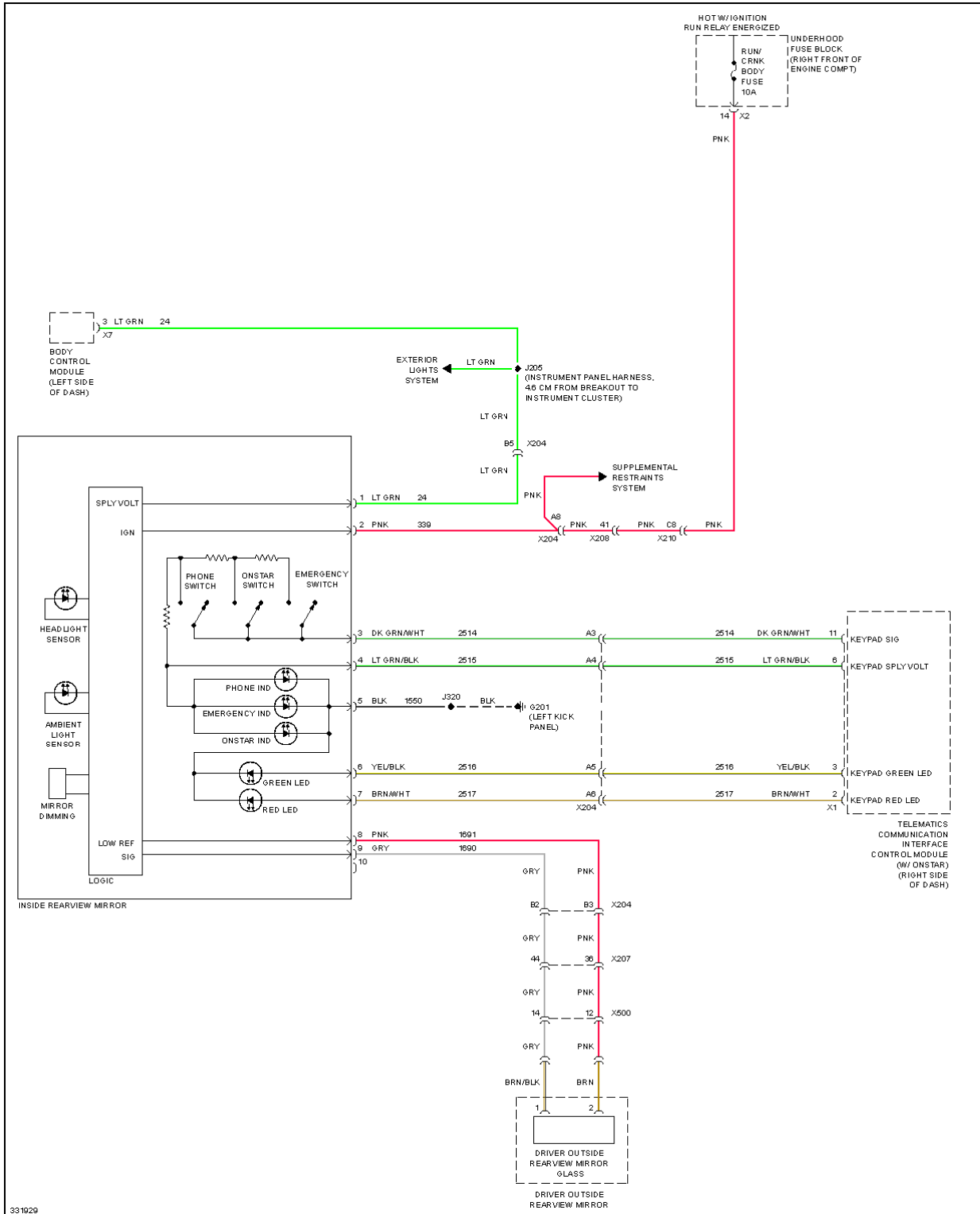

Fig. 51: Power Door Locks Circuit

POWER MIRRORS

2010 Chevrolet Camaro LS

2010 SYSTEM WIRING DIAGRAMS Chevrolet - Camaro



2010 Chevrolet Camaro LS

2010 SYSTEM WIRING DIAGRAMS Chevrolet - Camaro

Fig. 52: Electrochromic Mirror Circuit

2010 Chevrolet Camaro LS

2010 SYSTEM WIRING DIAGRAMS Chevrolet - Camaro

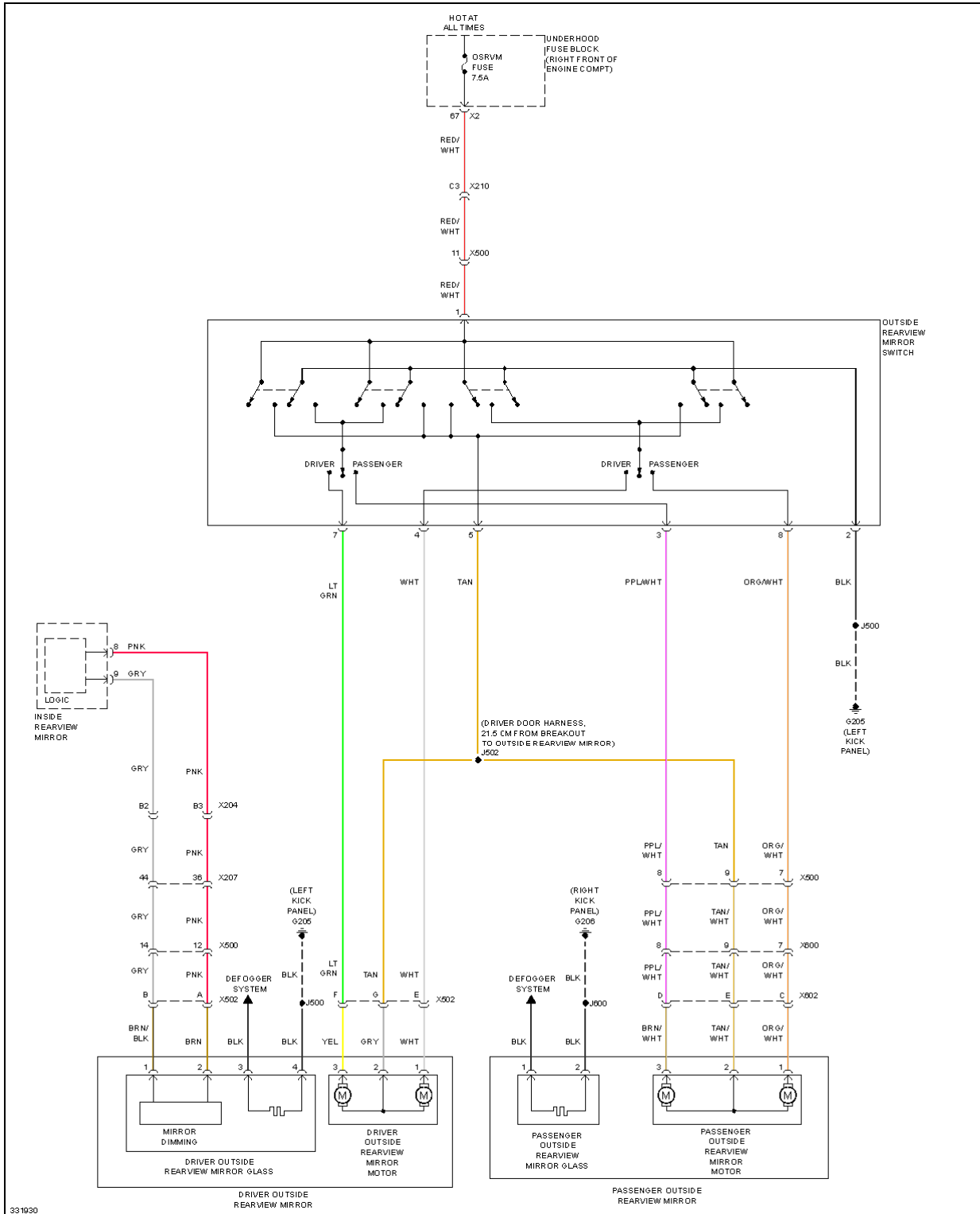
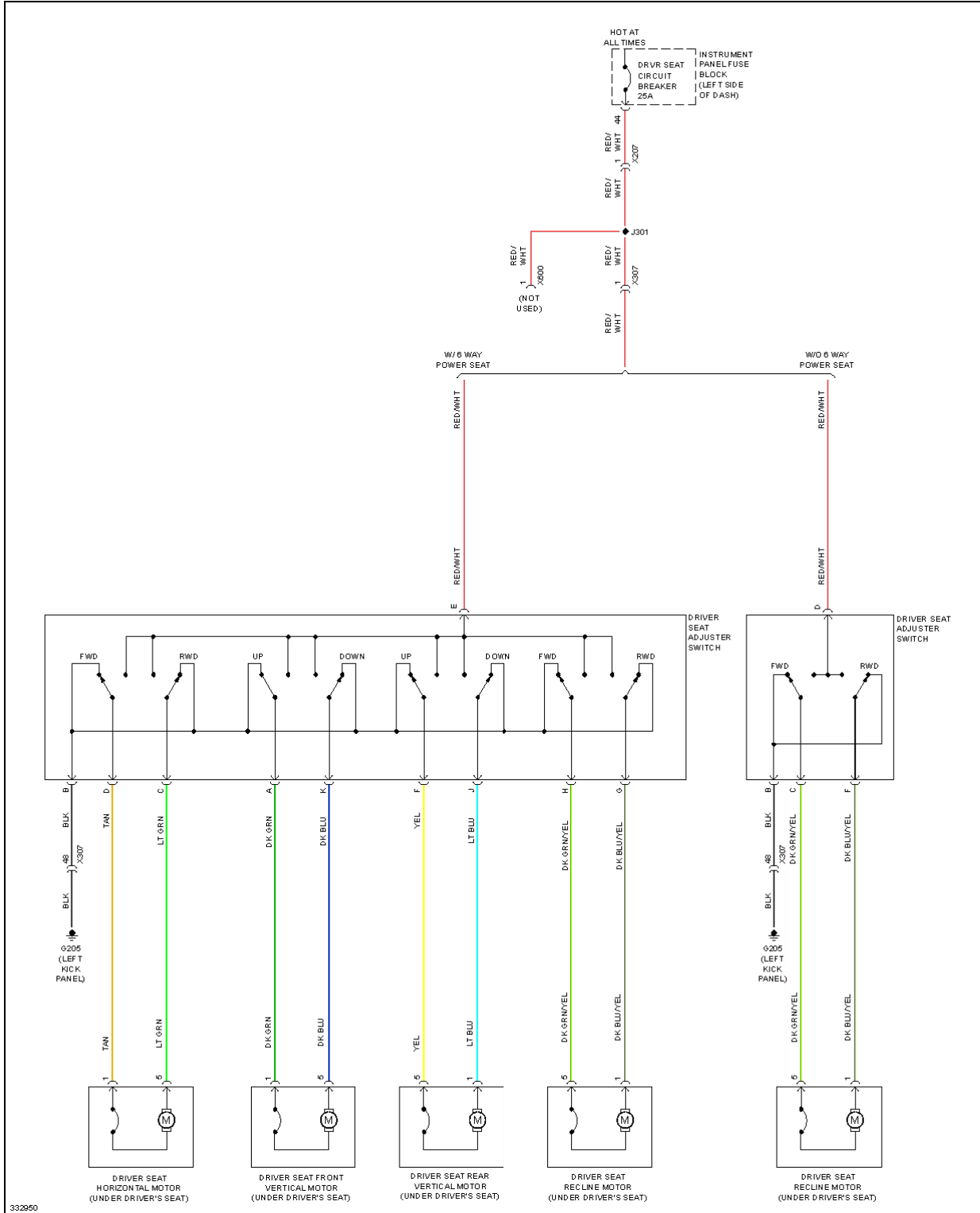

Fig. 53: Power Mirrors Circuit

POWER SEATS

2010 Chevrolet Camaro LS

2010 SYSTEM WIRING DIAGRAMS Chevrolet - Camaro



2010 Chevrolet Camaro LS

2010 SYSTEM WIRING DIAGRAMS Chevrolet - Camaro

Fig. 54: Driver Power Seat Circuit

2010 Chevrolet Camaro LS

2010 SYSTEM WIRING DIAGRAMS Chevrolet - Camaro

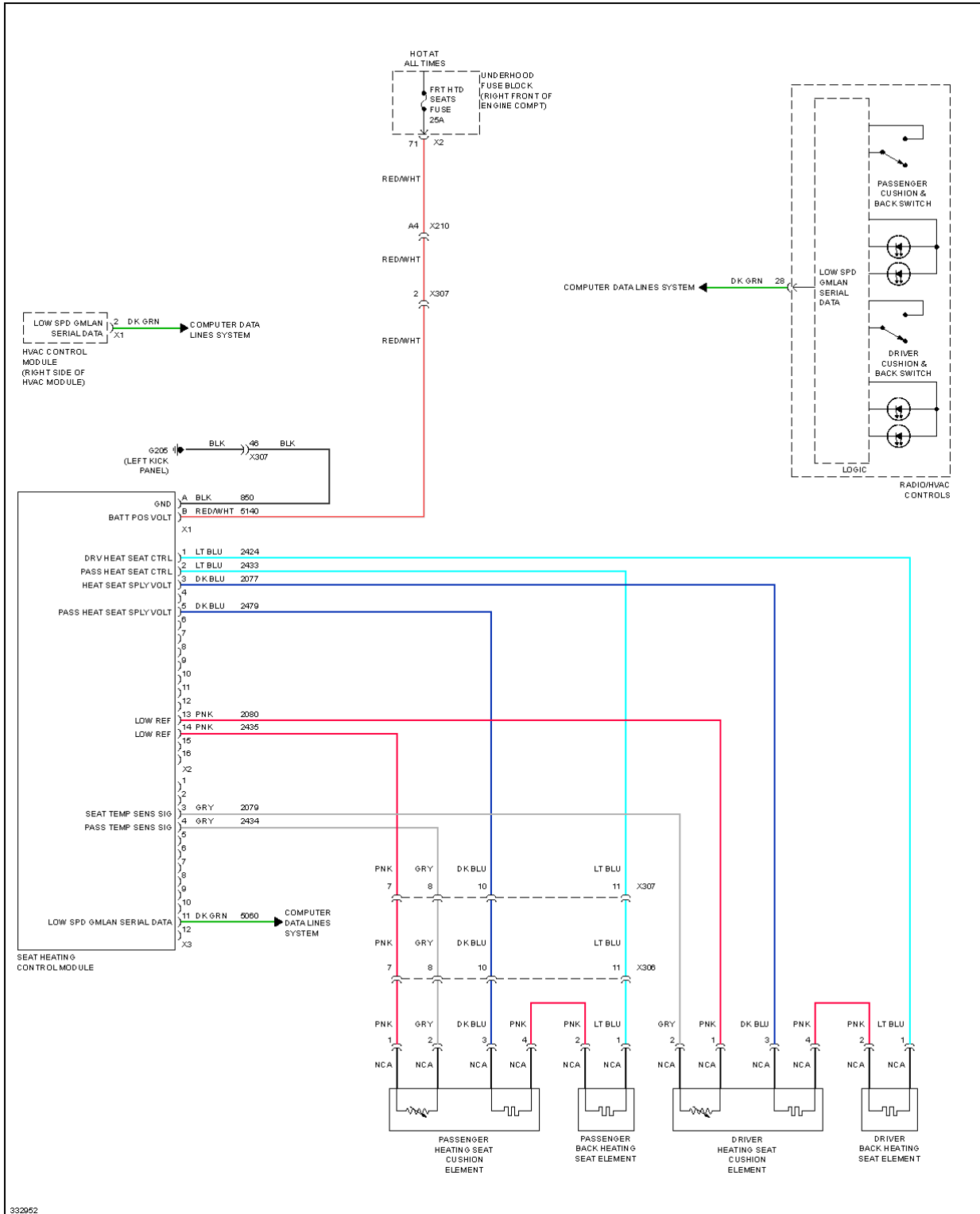

2010 Chevrolet Camaro LS

2010 SYSTEM WIRING DIAGRAMS Chevrolet - Camaro

Fig. 55: Heated Seats Circuit

2010 Chevrolet Camaro LS

2010 SYSTEM WIRING DIAGRAMS Chevrolet - Camaro

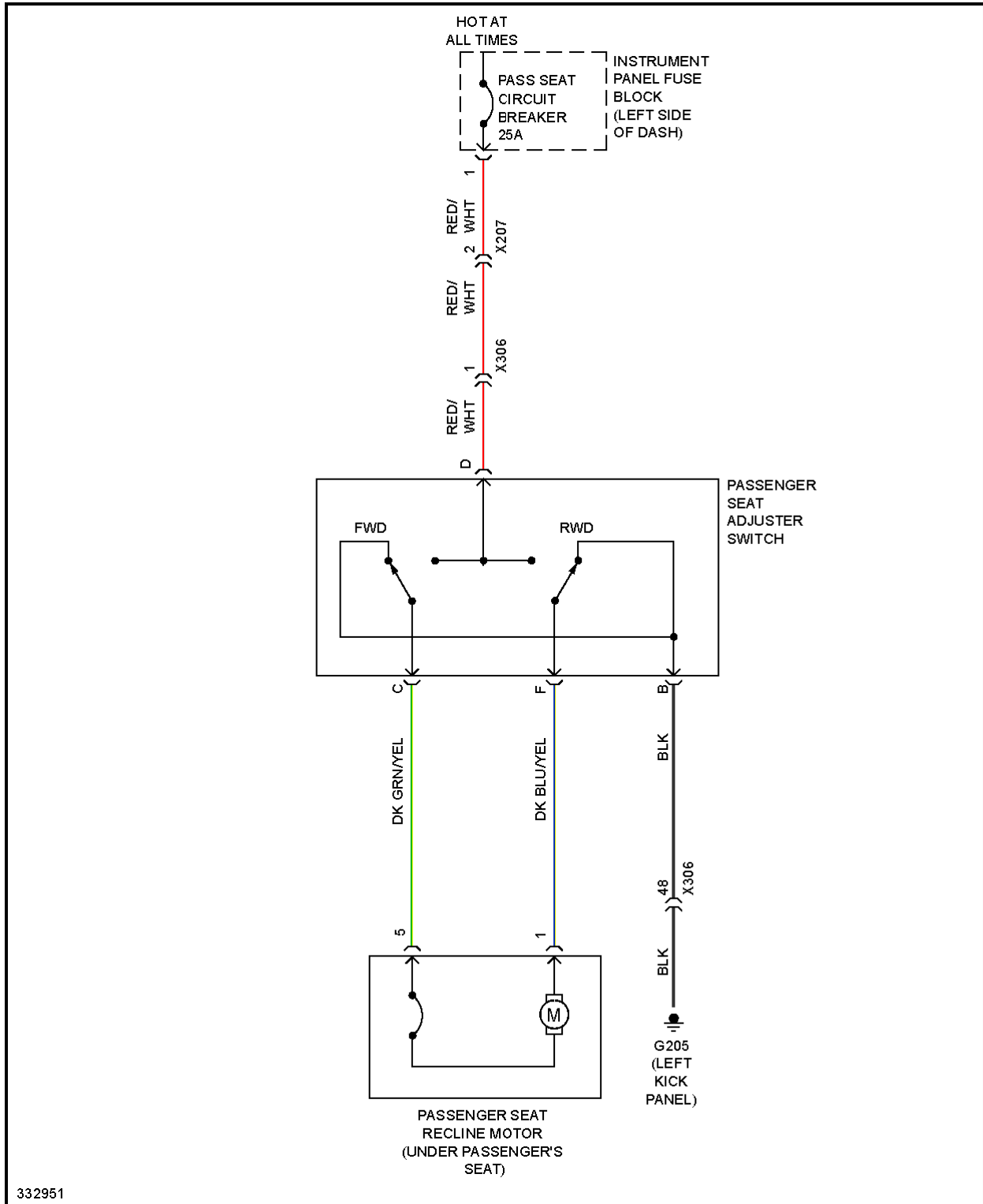

Fig. 56: Passenger Power Seat Circuit

POWER TOP/SUNROOF

2010 Chevrolet Camaro LS

2010 SYSTEM WIRING DIAGRAMS Chevrolet - Camaro

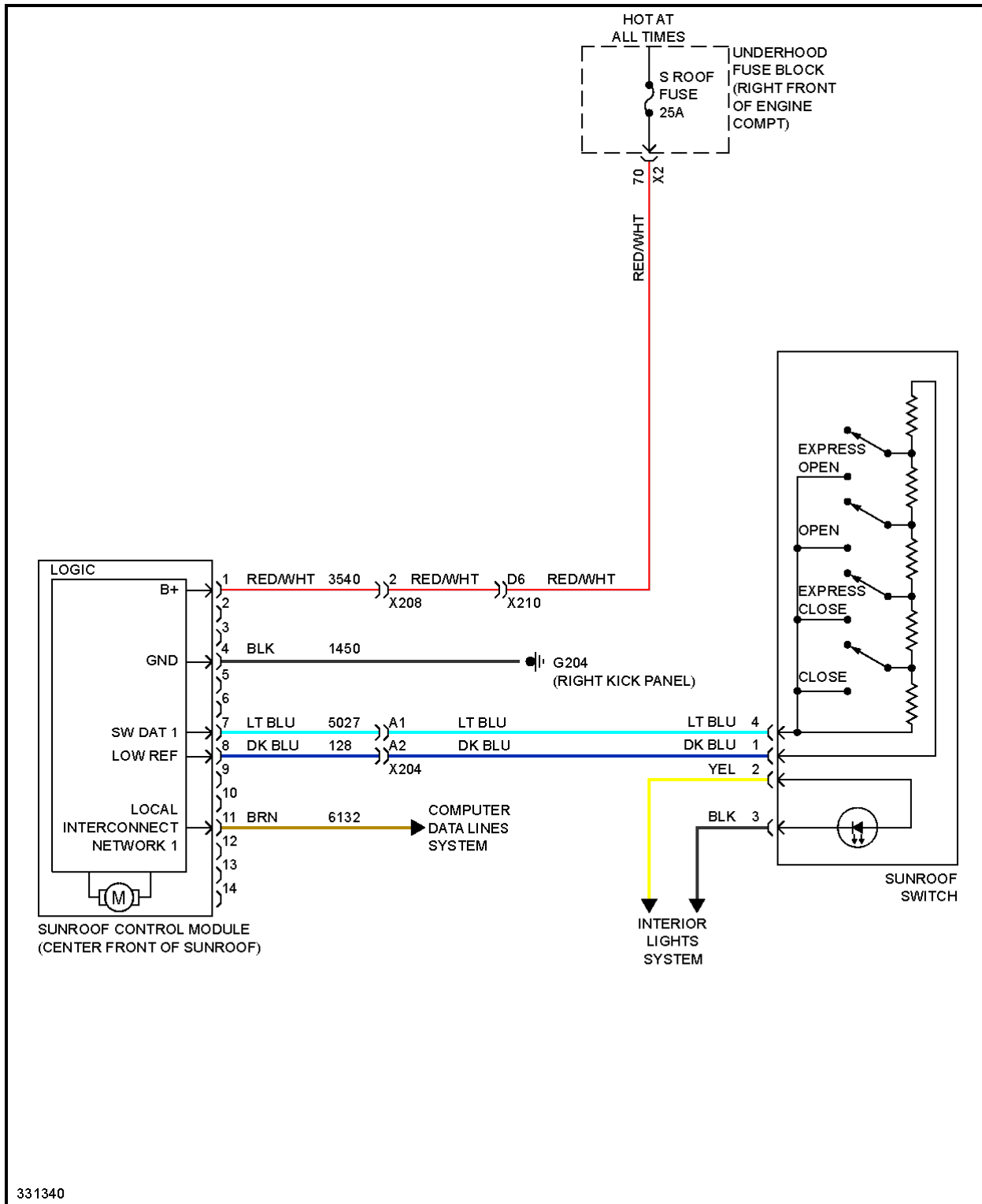

Fig. 57: Power Top/Sunroof Circuit

POWER WINDOWS

2010 Chevrolet Camaro LS

2010 SYSTEM WIRING DIAGRAMS Chevrolet - Camaro

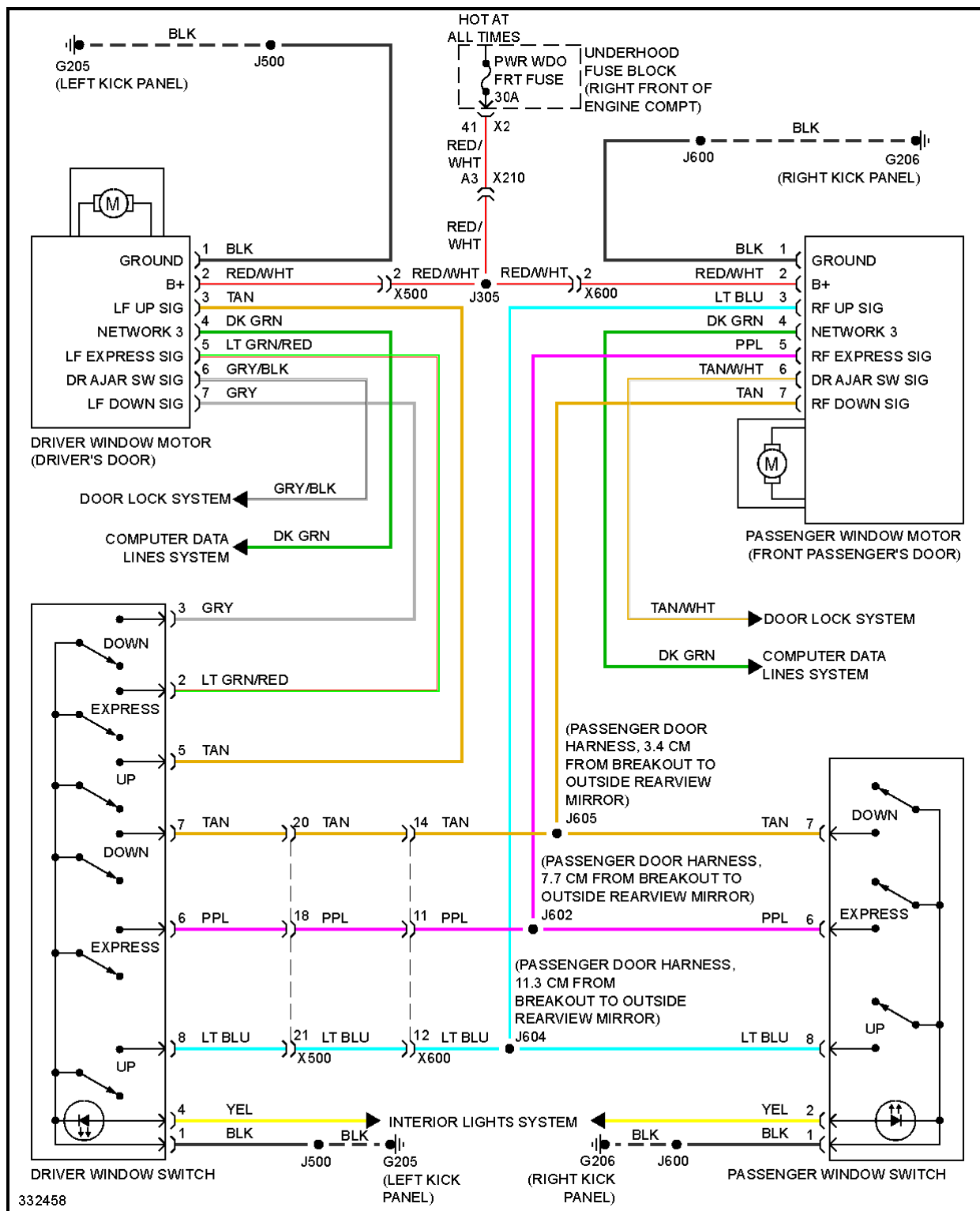
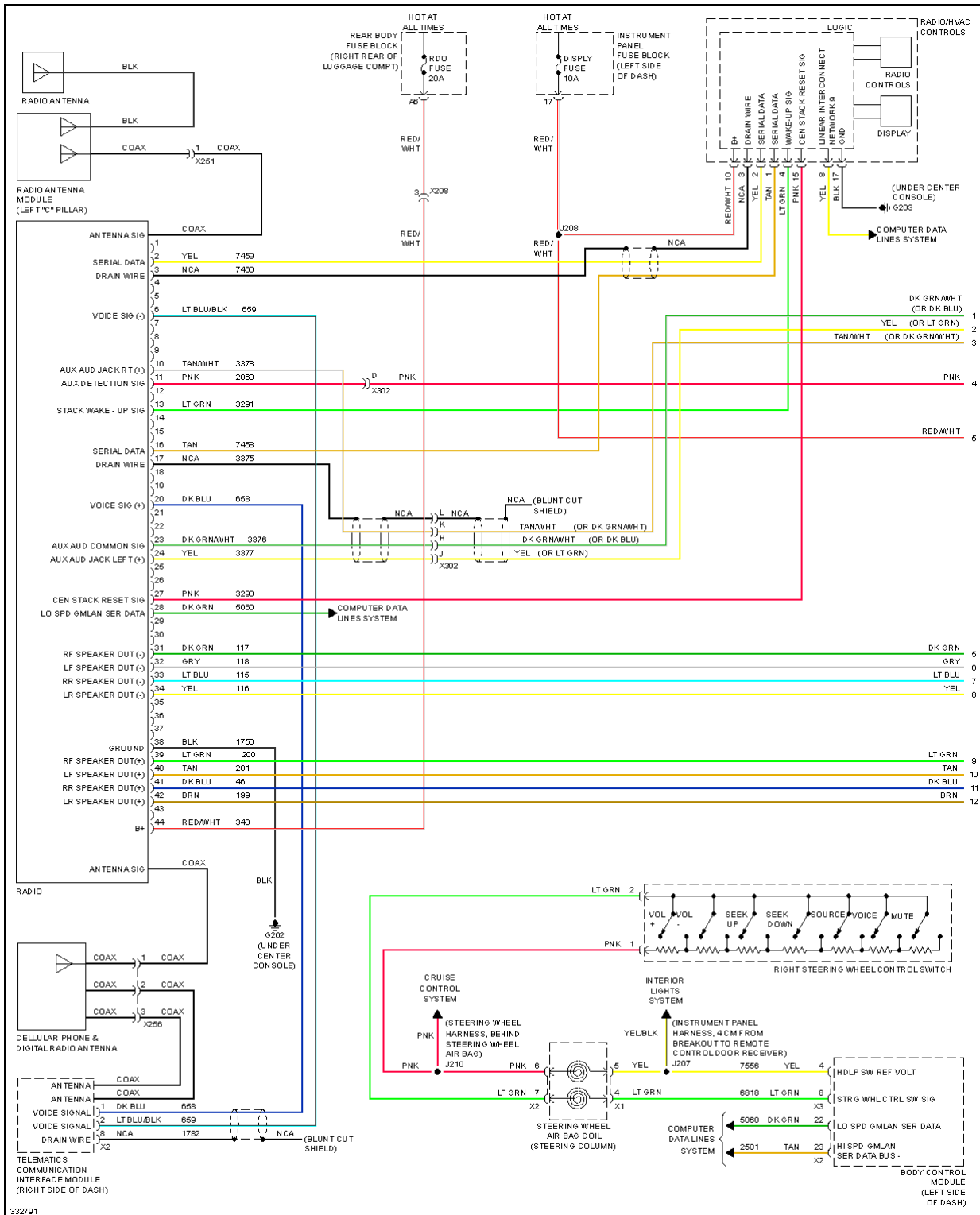

Fig. 58: Power Windows Circuit

RADIO

2010 Chevrolet Camaro LS

2010 SYSTEM WIRING DIAGRAMS Chevrolet - Camaro



2010 Chevrolet Camaro LS

2010 SYSTEM WIRING DIAGRAMS Chevrolet - Camaro

Fig. 59: Base Radio Circuit (1 of 2)

2010 Chevrolet Camaro LS

2010 SYSTEM WIRING DIAGRAMS Chevrolet - Camaro

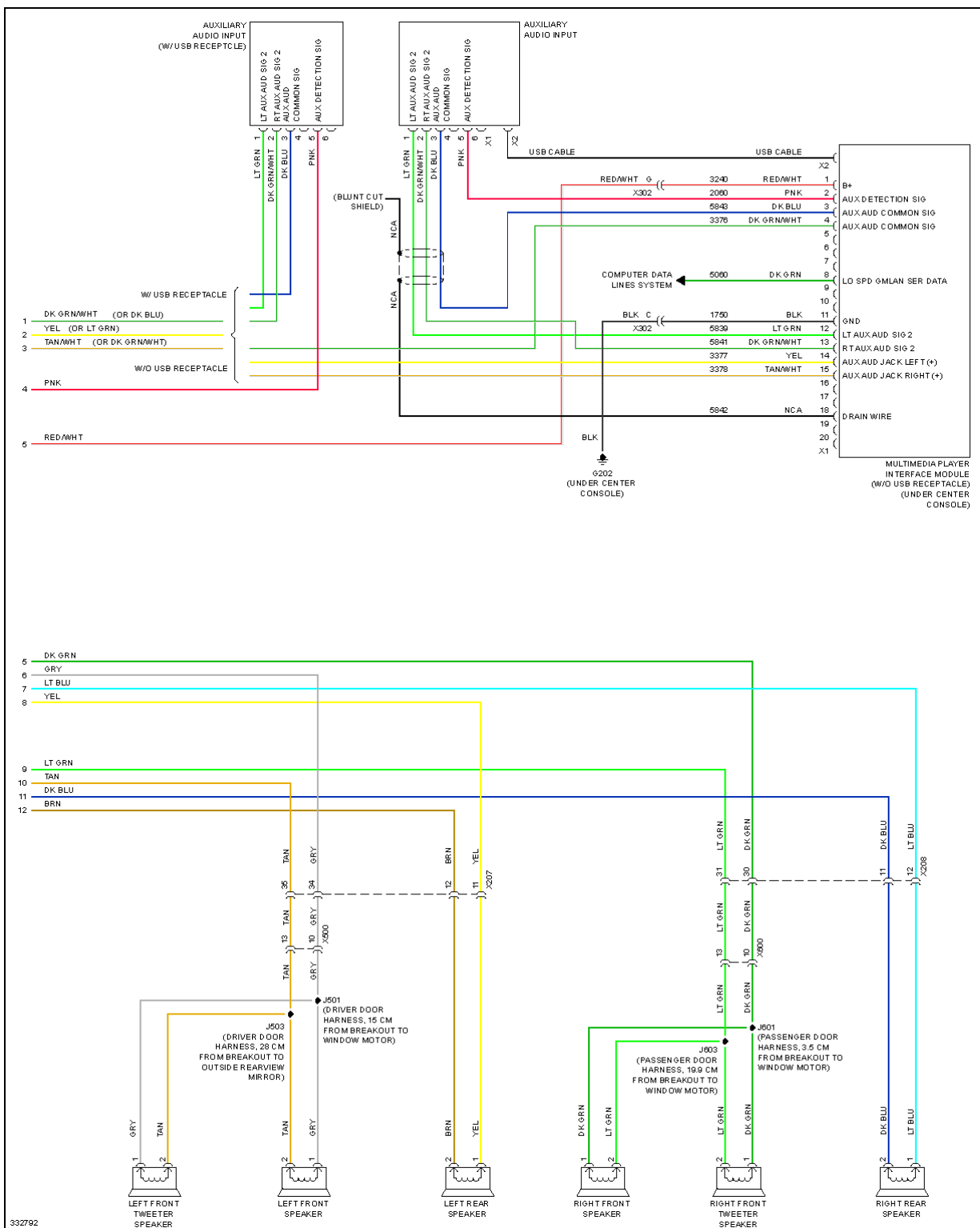

2010 Chevrolet Camaro LS

2010 SYSTEM WIRING DIAGRAMS Chevrolet - Camaro

Fig. 60: Base Radio Circuit (2 of 2)

2010 Chevrolet Camaro LS

2010 SYSTEM WIRING DIAGRAMS Chevrolet - Camaro

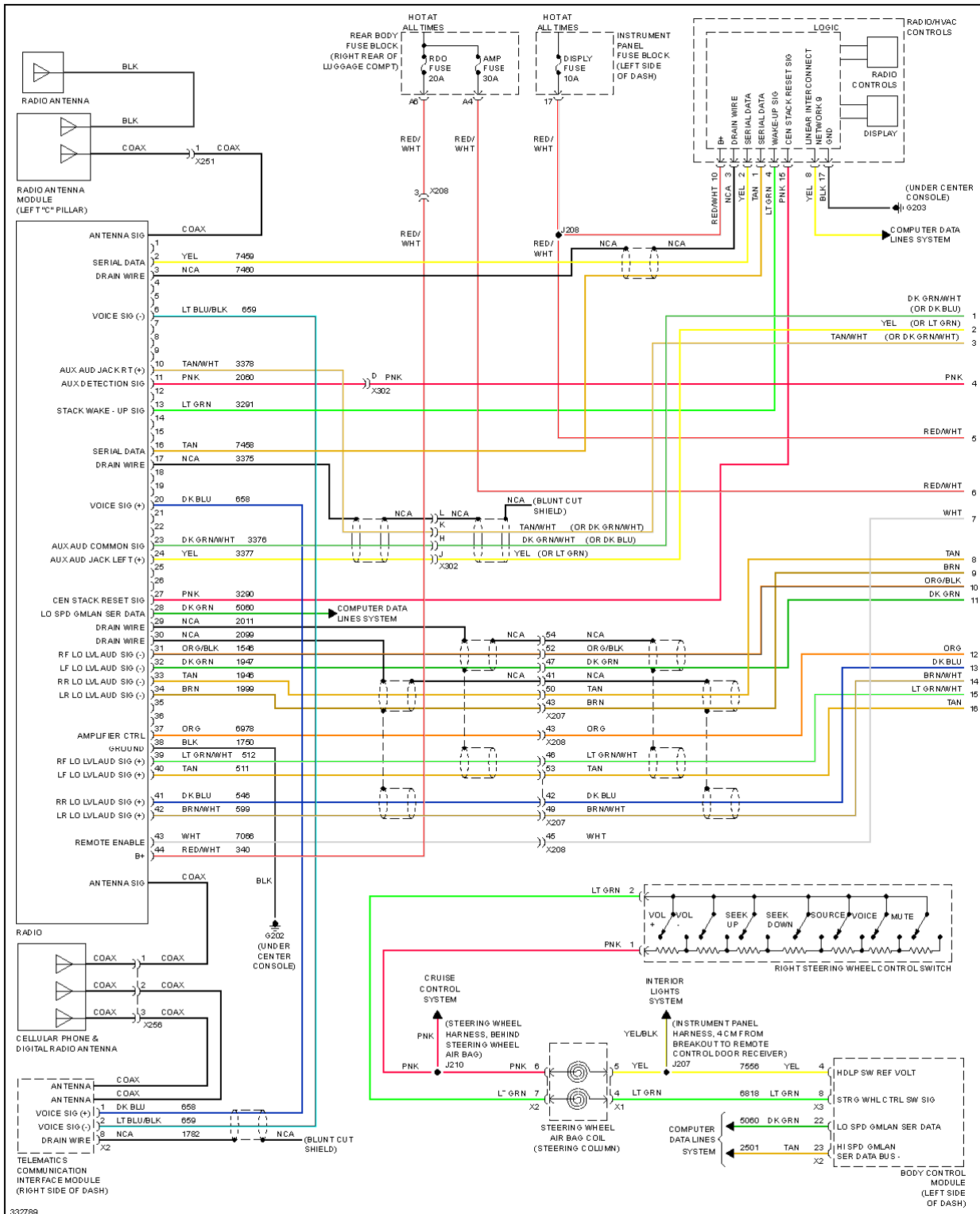

2010 Chevrolet Camaro LS

2010 SYSTEM WIRING DIAGRAMS Chevrolet - Camaro

Fig. 61: Premium Radio Circuit (1 of 2)

2010 Chevrolet Camaro LS

2010 SYSTEM WIRING DIAGRAMS Chevrolet - Camaro

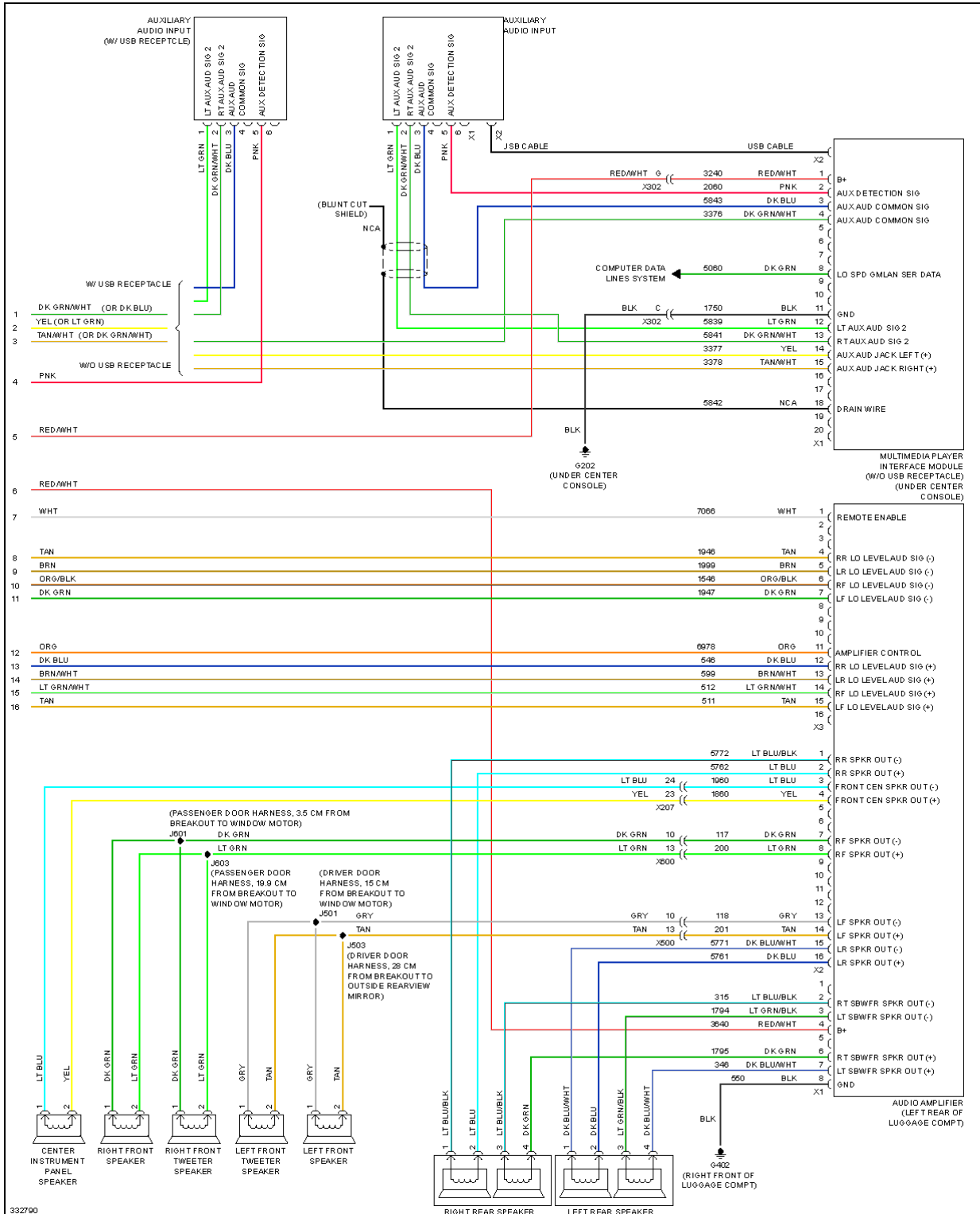
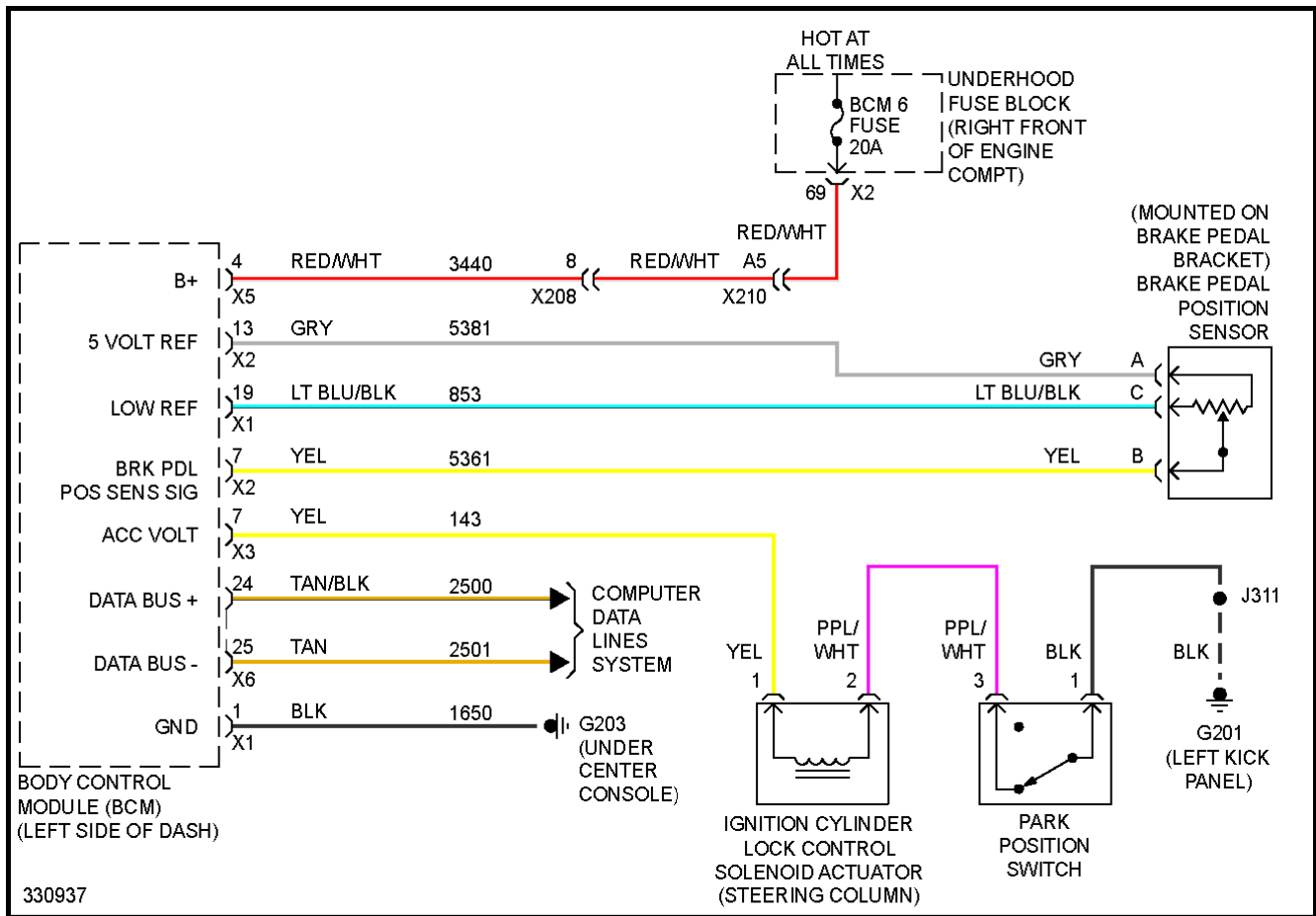

Fig. 62: Premium Radio Circuit (2 of 2)

SHIFT INTERLOCK

2010 Chevrolet Camaro LS

2010 SYSTEM WIRING DIAGRAMS Chevrolet - Camaro



2010 Chevrolet Camaro LS

2010 SYSTEM WIRING DIAGRAMS Chevrolet - Camaro

Fig. 63: Ignition Lock Solenoid Circuit

2010 Chevrolet Camaro LS

2010 SYSTEM WIRING DIAGRAMS Chevrolet - Camaro

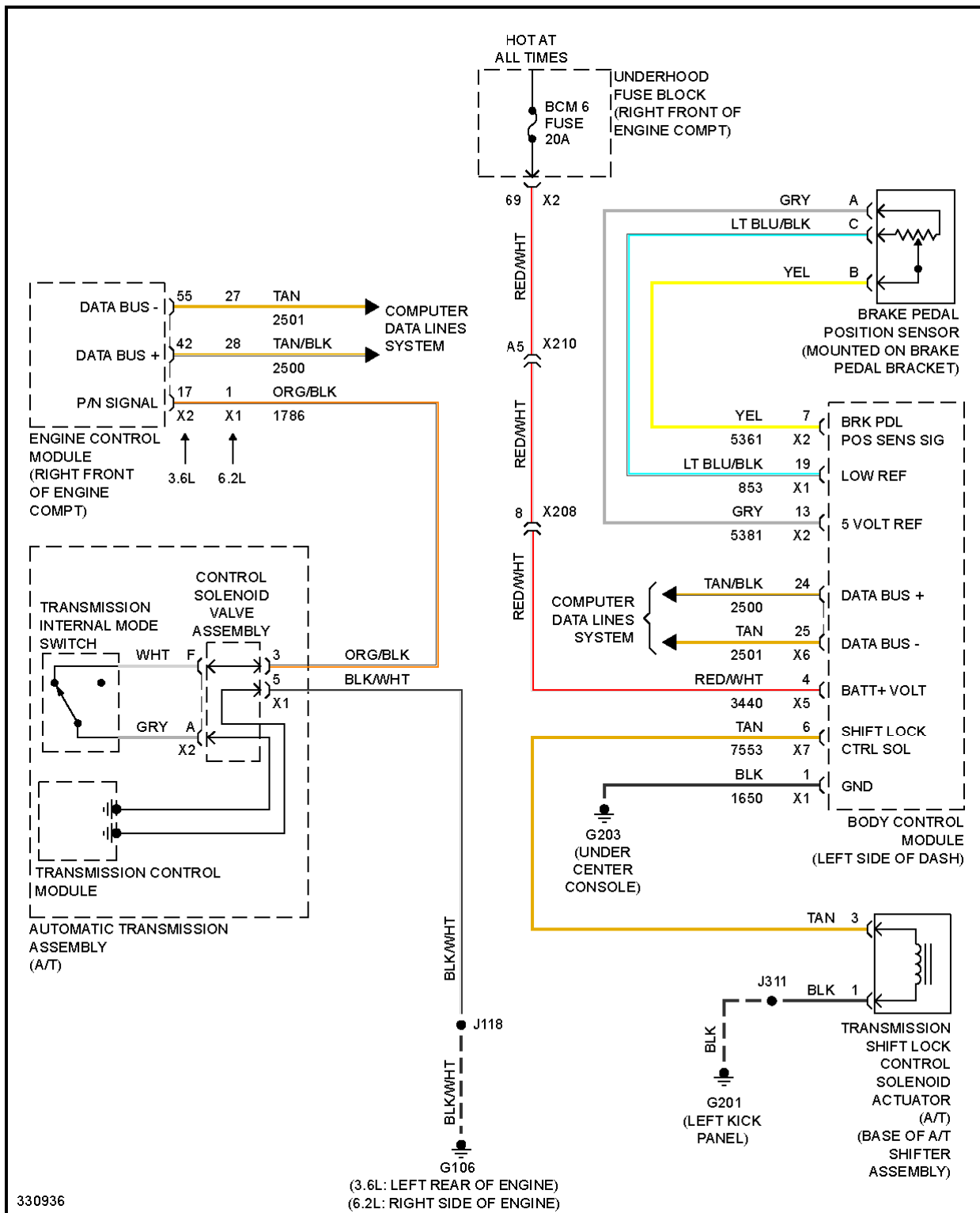
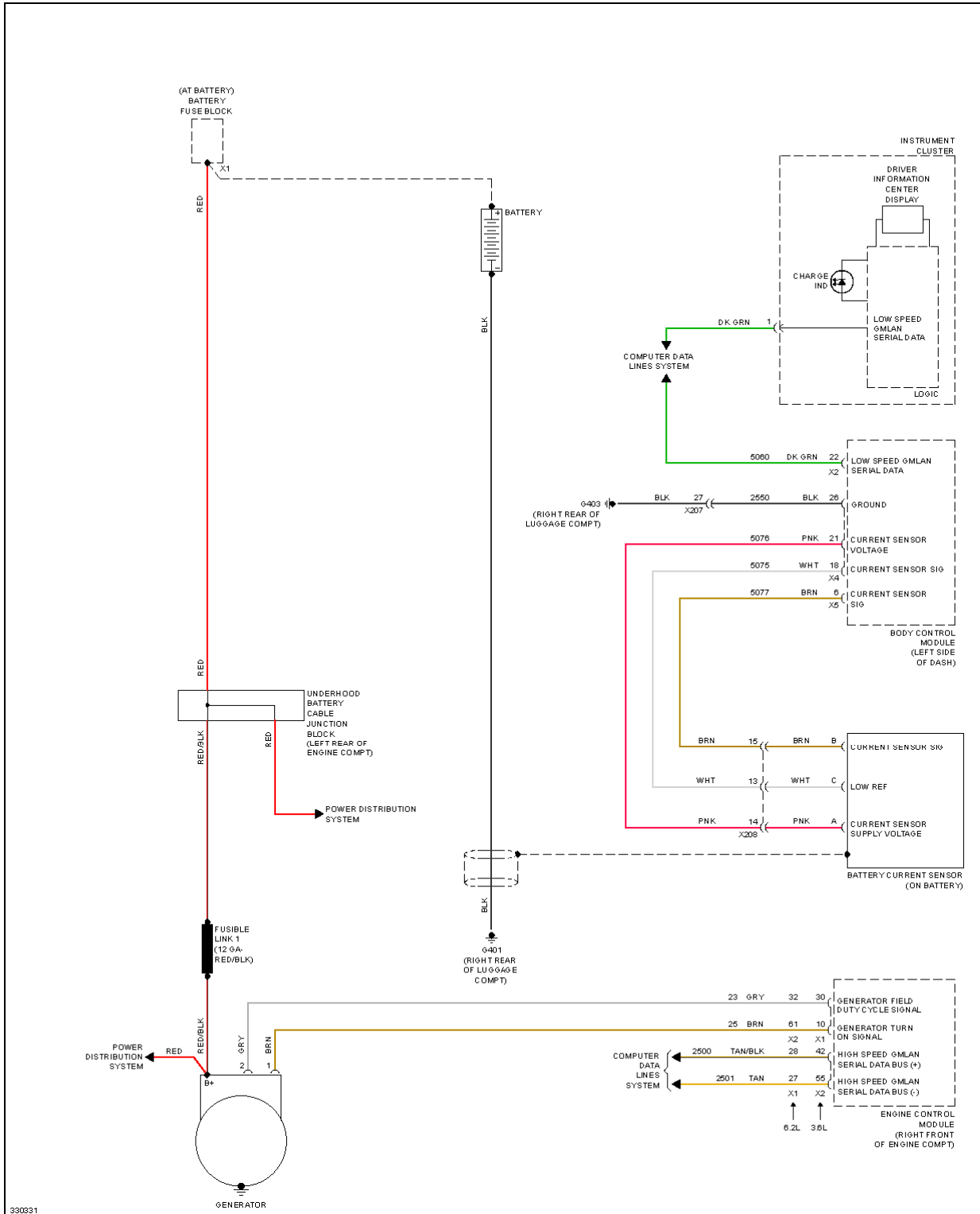

Fig. 64: Shift Interlock Circuit

STARTING/CHARGING

2010 Chevrolet Camaro LS

2010 SYSTEM WIRING DIAGRAMS Chevrolet - Camaro



2010 Chevrolet Camaro LS

2010 SYSTEM WIRING DIAGRAMS Chevrolet - Camaro

Fig. 65: Charging Circuit

2010 Chevrolet Camaro LS

2010 SYSTEM WIRING DIAGRAMS Chevrolet - Camaro

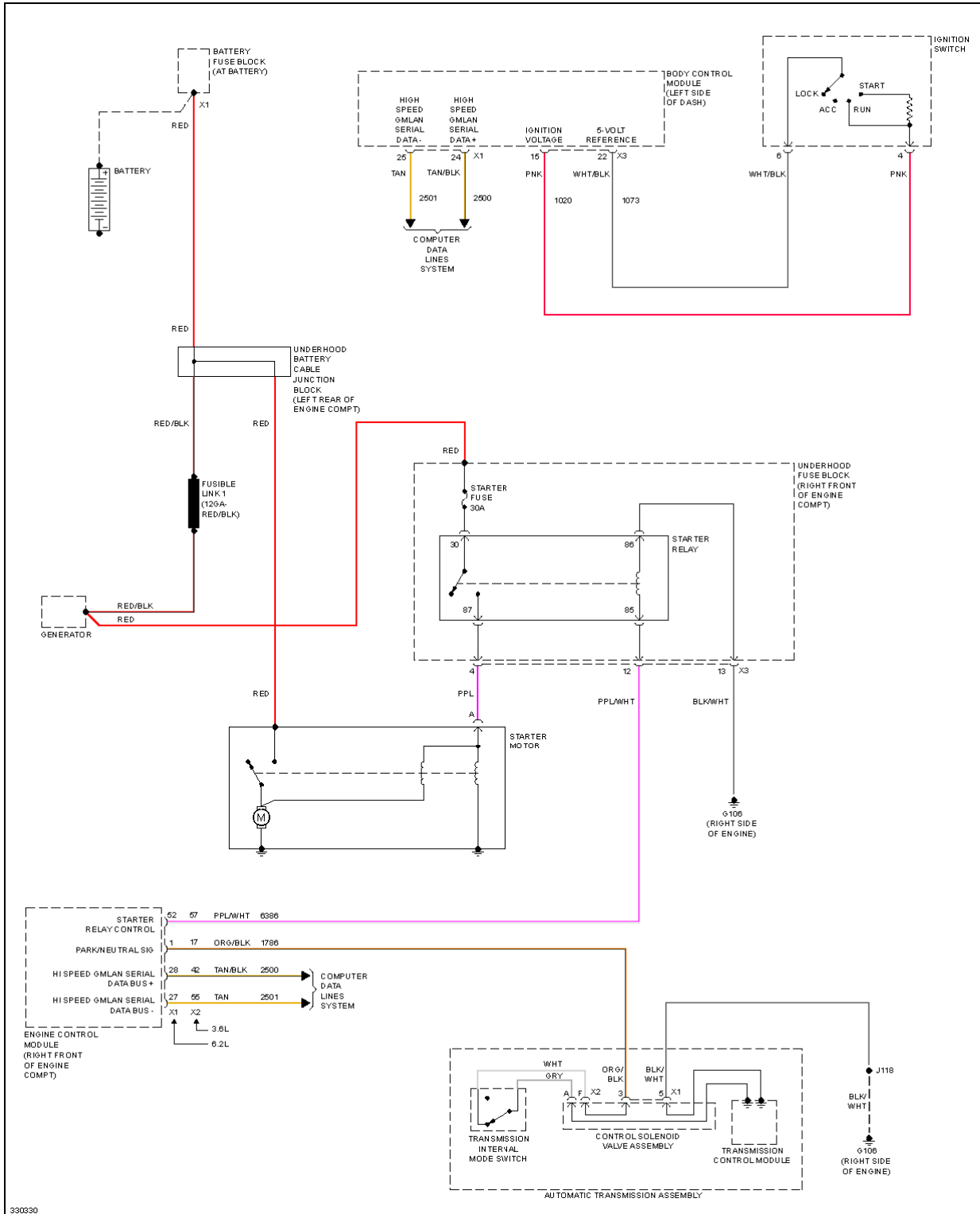
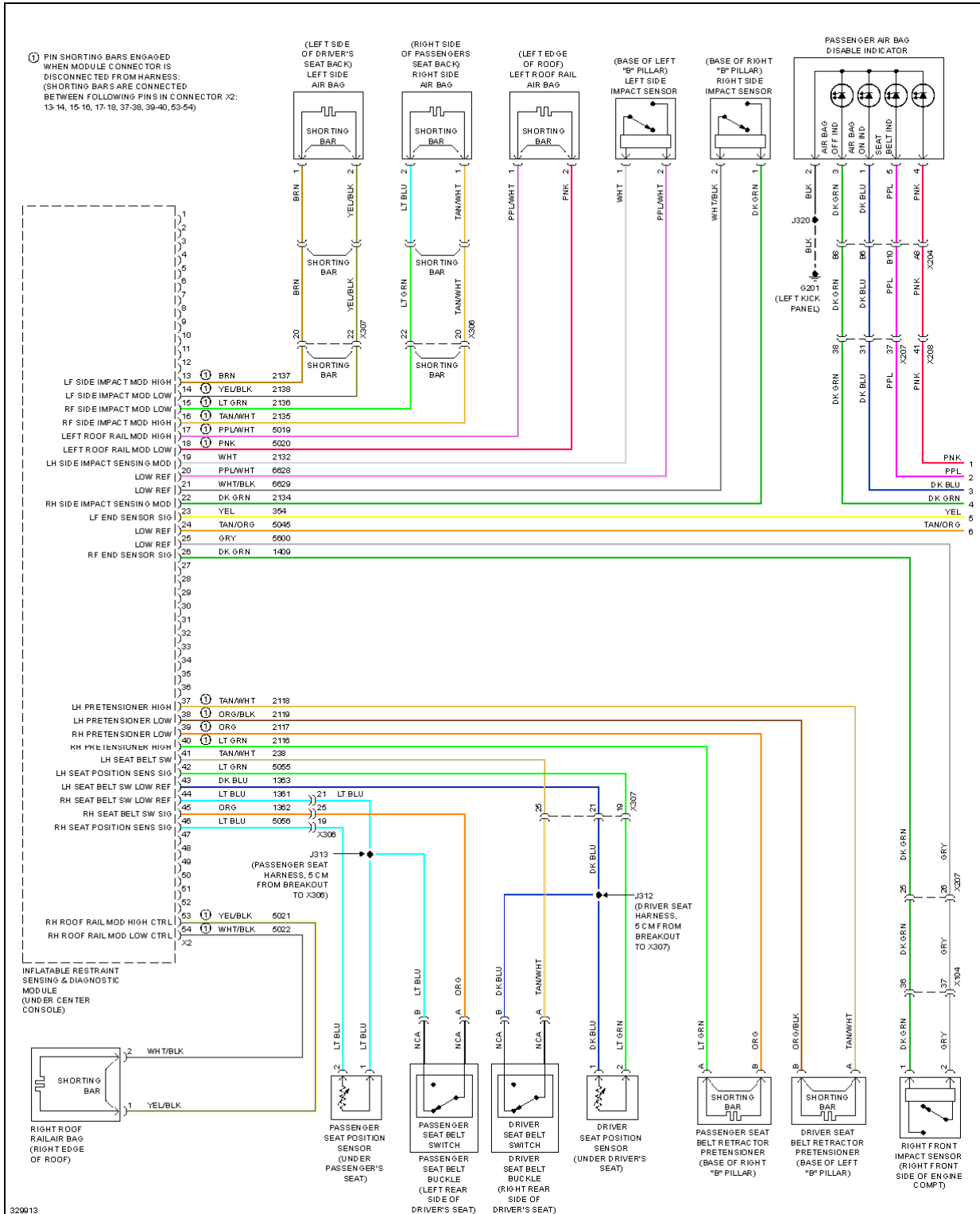

Fig. 66: Starting Circuit

SUPPLEMENTAL RESTRAINTS

2010 Chevrolet Camaro LS

2010 SYSTEM WIRING DIAGRAMS Chevrolet - Camaro



2010 Chevrolet Camaro LS

2010 SYSTEM WIRING DIAGRAMS Chevrolet - Camaro

Fig. 67: Supplemental Restraints Circuit (1 of 2)

2010 Chevrolet Camaro LS

2010 SYSTEM WIRING DIAGRAMS Chevrolet - Camaro

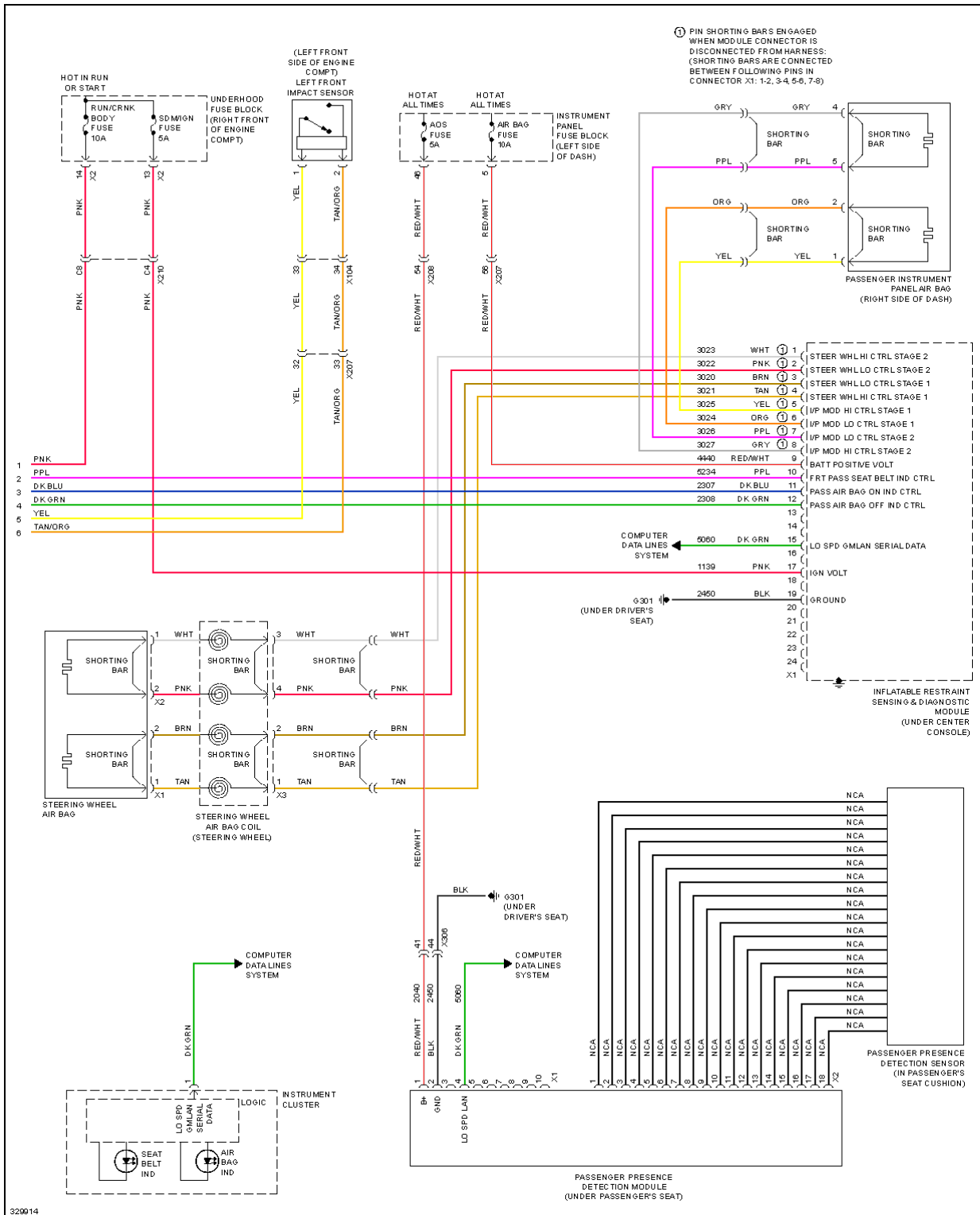

Fig. 68: Supplemental Restraints Circuit (2 of 2)

TRANSMISSION

2010 Chevrolet Camaro LS

2010 SYSTEM WIRING DIAGRAMS Chevrolet - Camaro

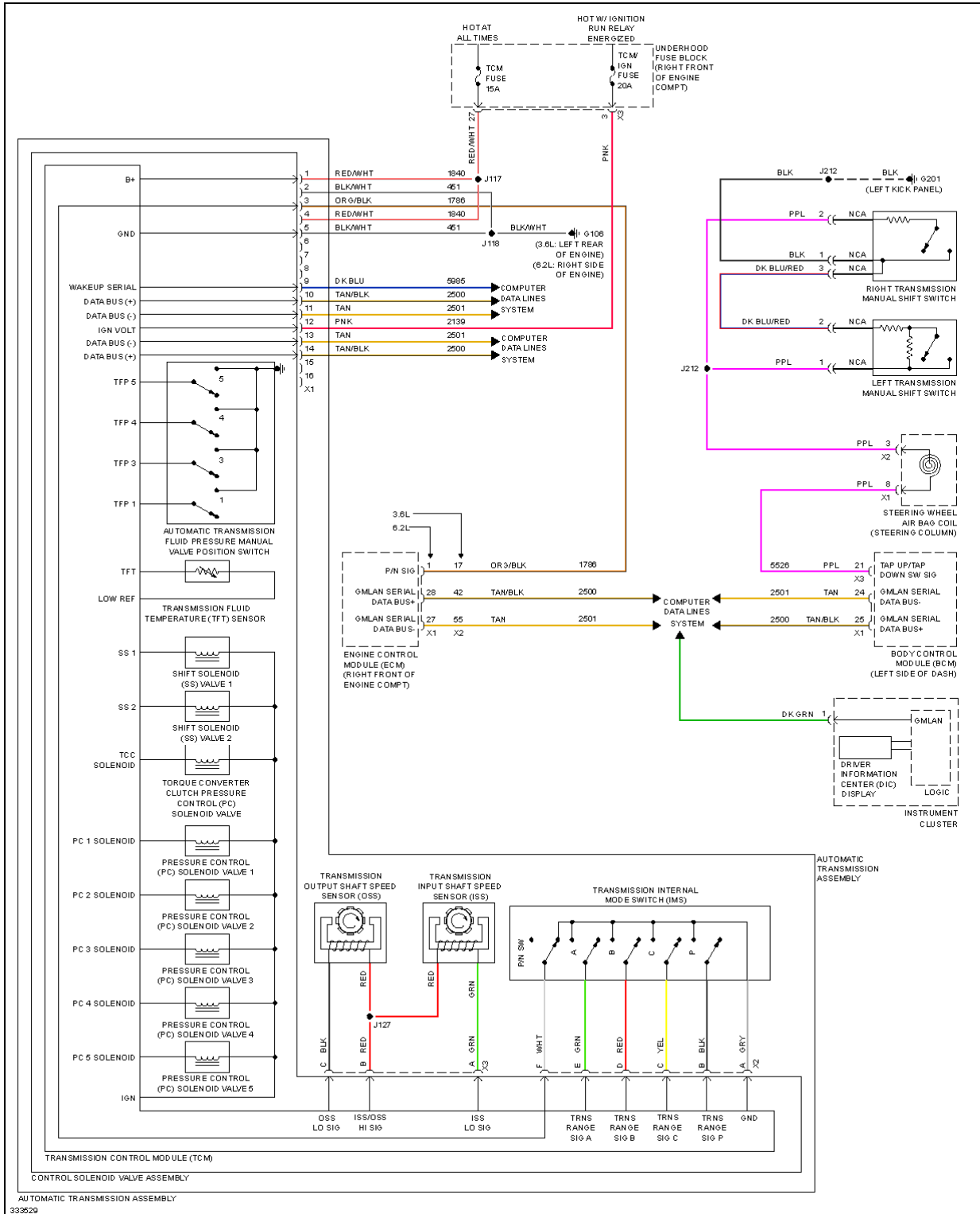

Fig. 69: Transmission Circuit

TRUNK, TAILGATE, FUEL DOOR

2010 Chevrolet Camaro LS

2010 SYSTEM WIRING DIAGRAMS Chevrolet - Camaro

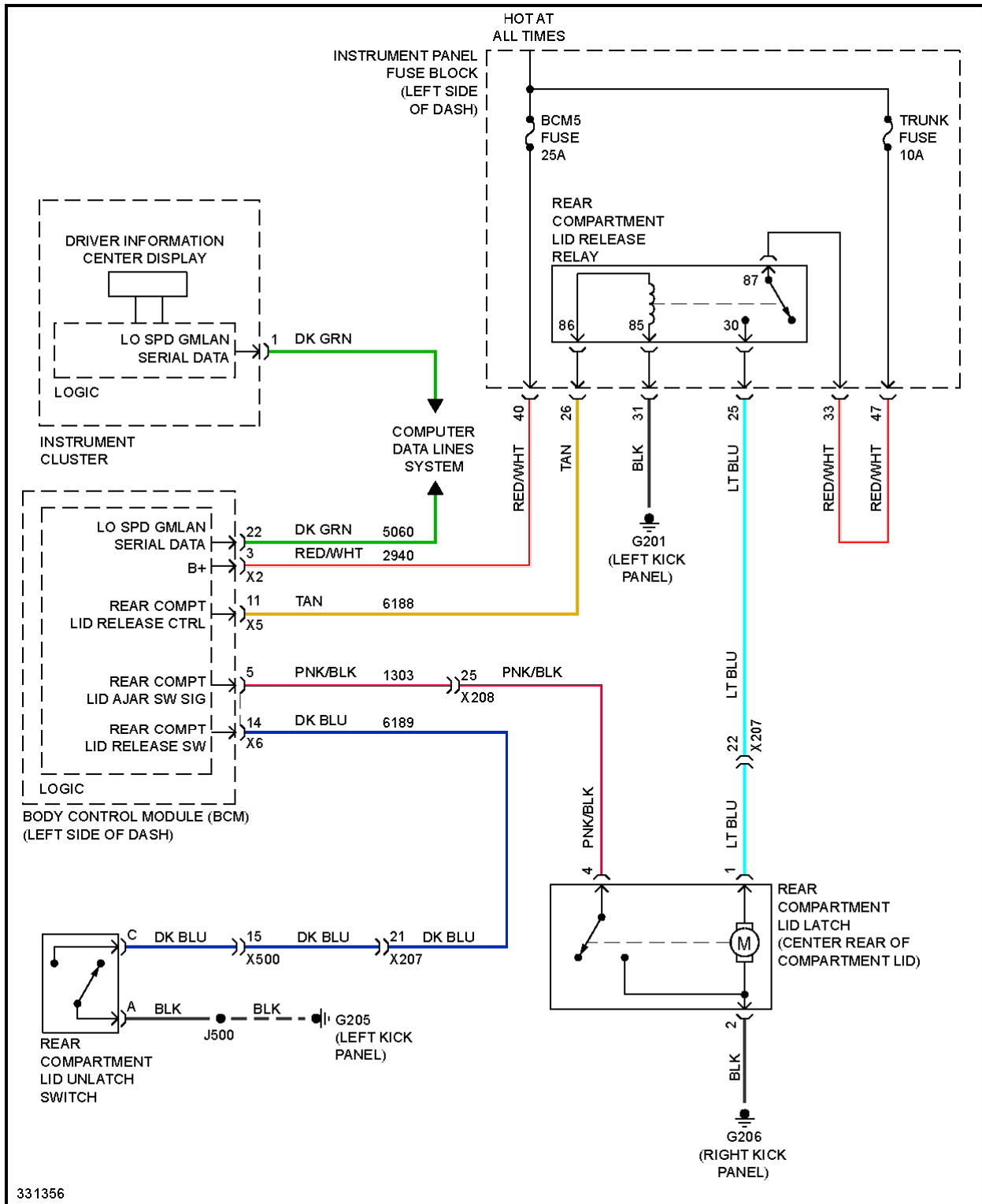

Fig. 70: Trunk Release Circuit

WARNING SYSTEMS

2010 Chevrolet Camaro LS

2010 SYSTEM WIRING DIAGRAMS Chevrolet - Camaro

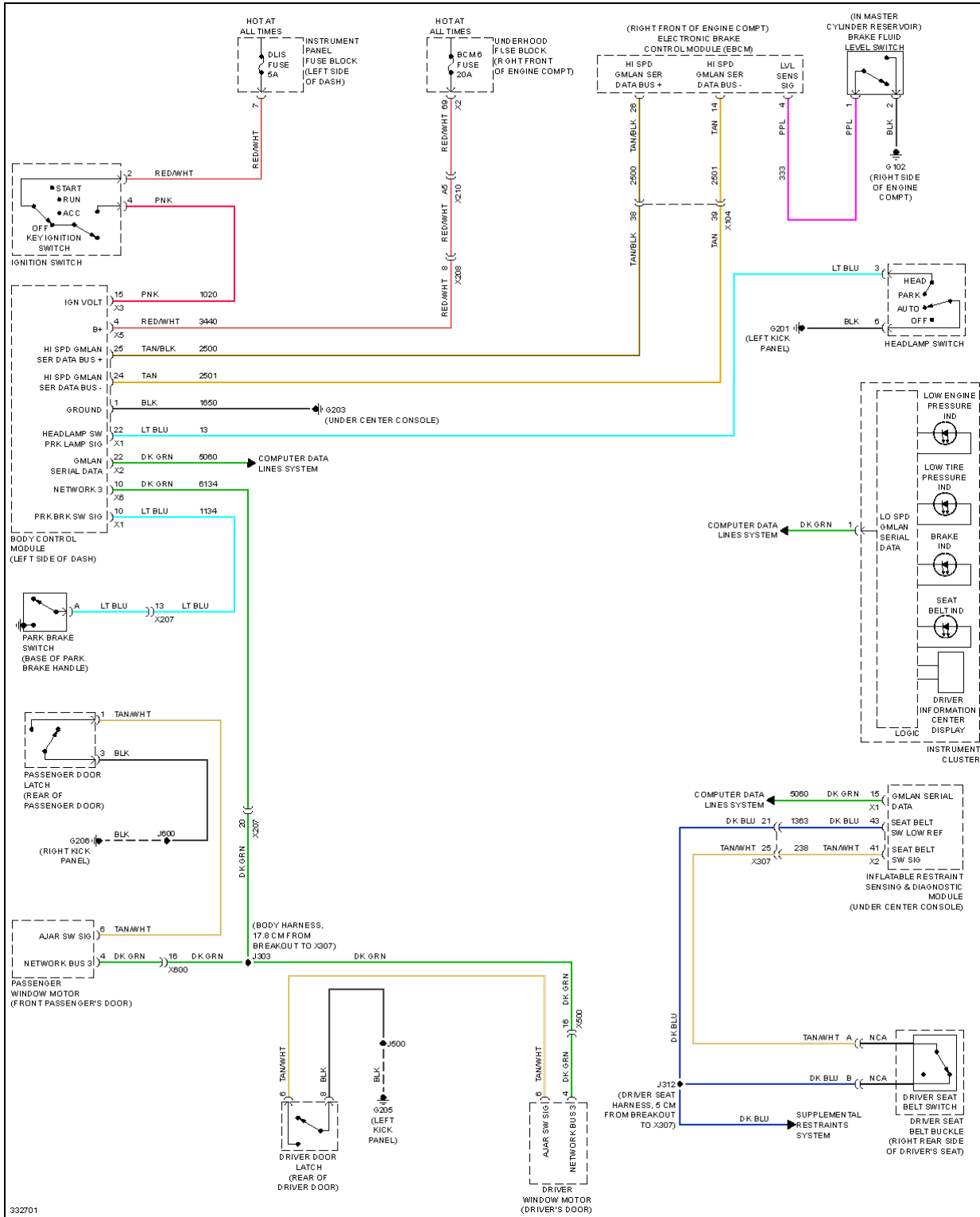
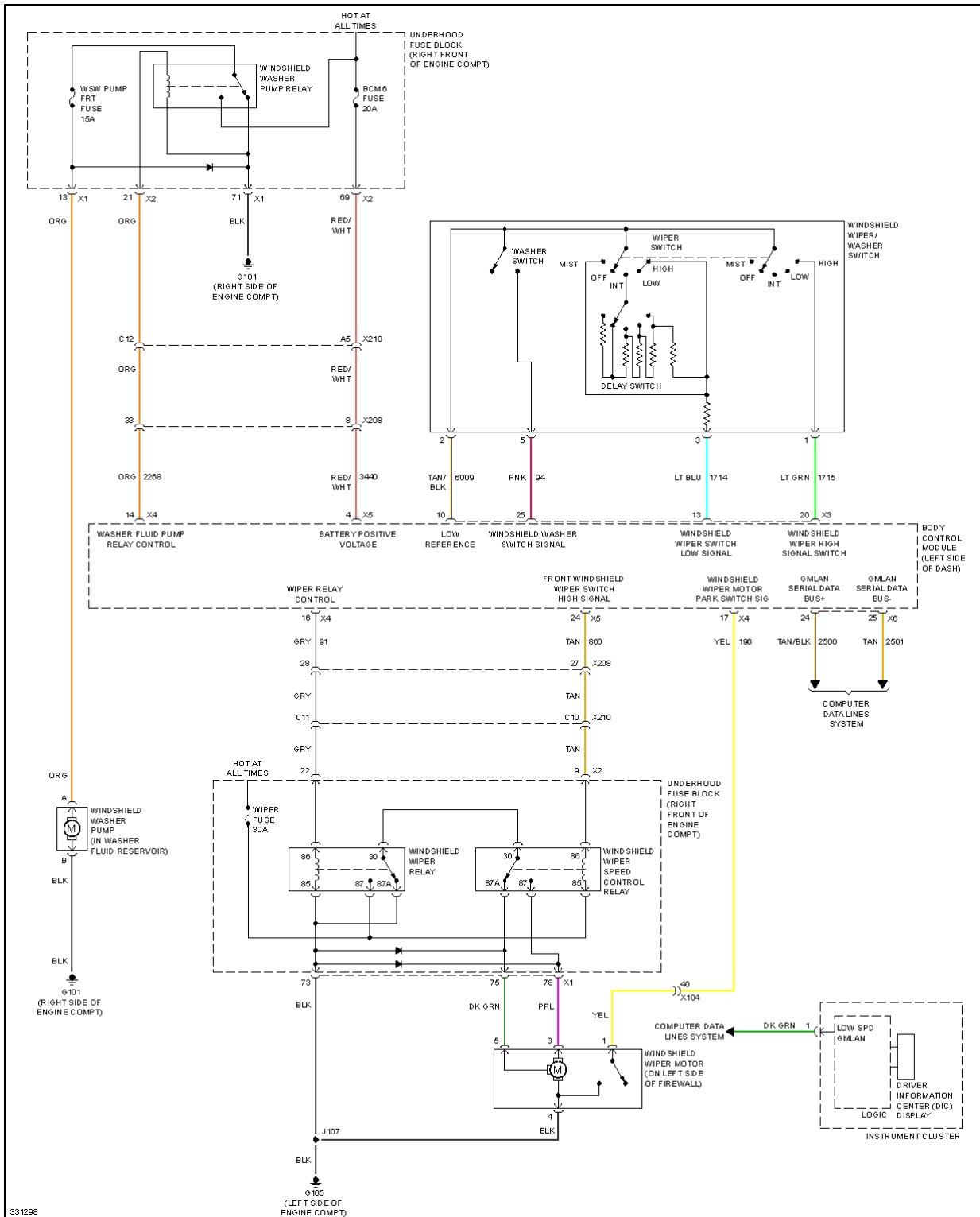

Fig. 71: Warning Systems Circuit

WIPER/WASHER

2010 Chevrolet Camaro LS

2010 SYSTEM WIRING DIAGRAMS Chevrolet - Camaro



2010 Chevrolet Camaro LS

2010 SYSTEM WIRING DIAGRAMS Chevrolet - Camaro

Fig. 72: Wiper/Washer Circuit