

# SYSTEM WIRING DIAGRAMS

## 3.1L (VIN D), Cooling Fan Circuit, W/ Pusher Fan

1993 Pontiac Trans Sport

For x

Copyright © 1998 Mitchell Repair Information Company, LLC

Friday, November 26, 2004 07:52AM

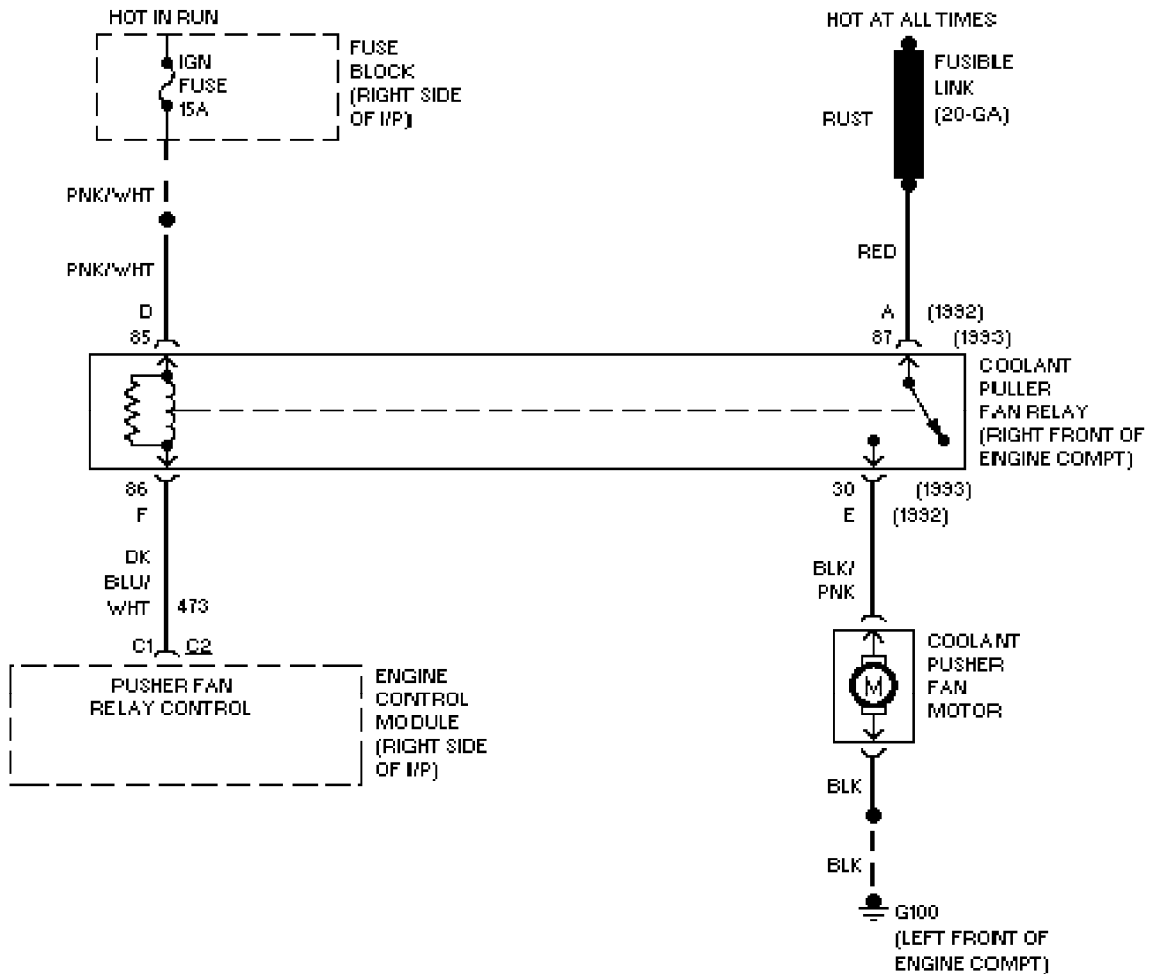

# SYSTEM WIRING DIAGRAMS

## 3.1L (VIN D), Cooling Fan Circuit, W/O Pusher Fan (p. 2)

1993 Pontiac Trans Sport

For x

Copyright © 1998 Mitchell Repair Information Company, LLC

Friday, November 26, 2004 07:52AM

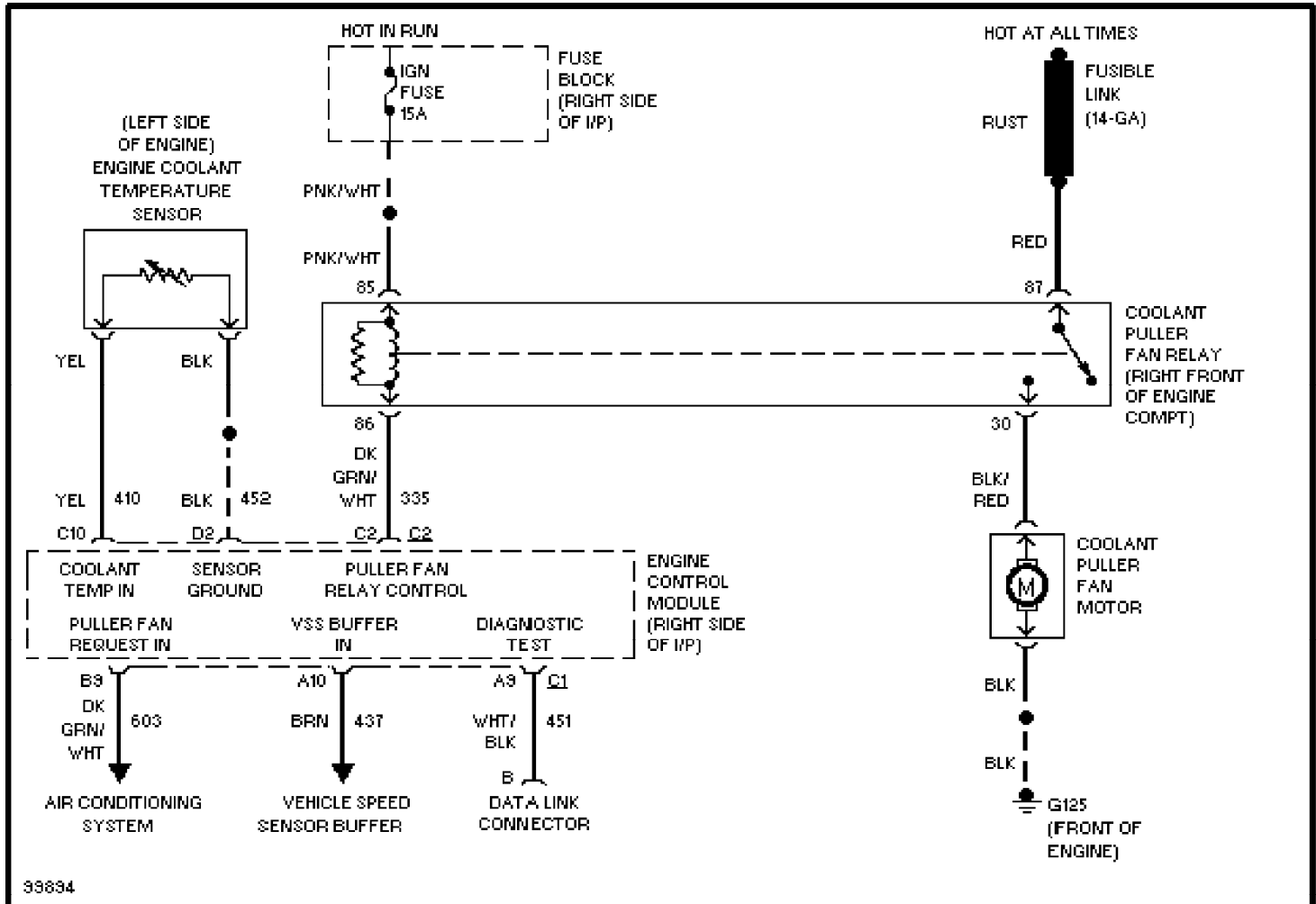

# SYSTEM WIRING DIAGRAMS

## 3.8L (VIN L), Cooling Fan Circuit (p. 3)

1993 Pontiac Trans Sport

For x

Copyright © 1998 Mitchell Repair Information Company, LLC  
Friday, November 26, 2004 07:52AM

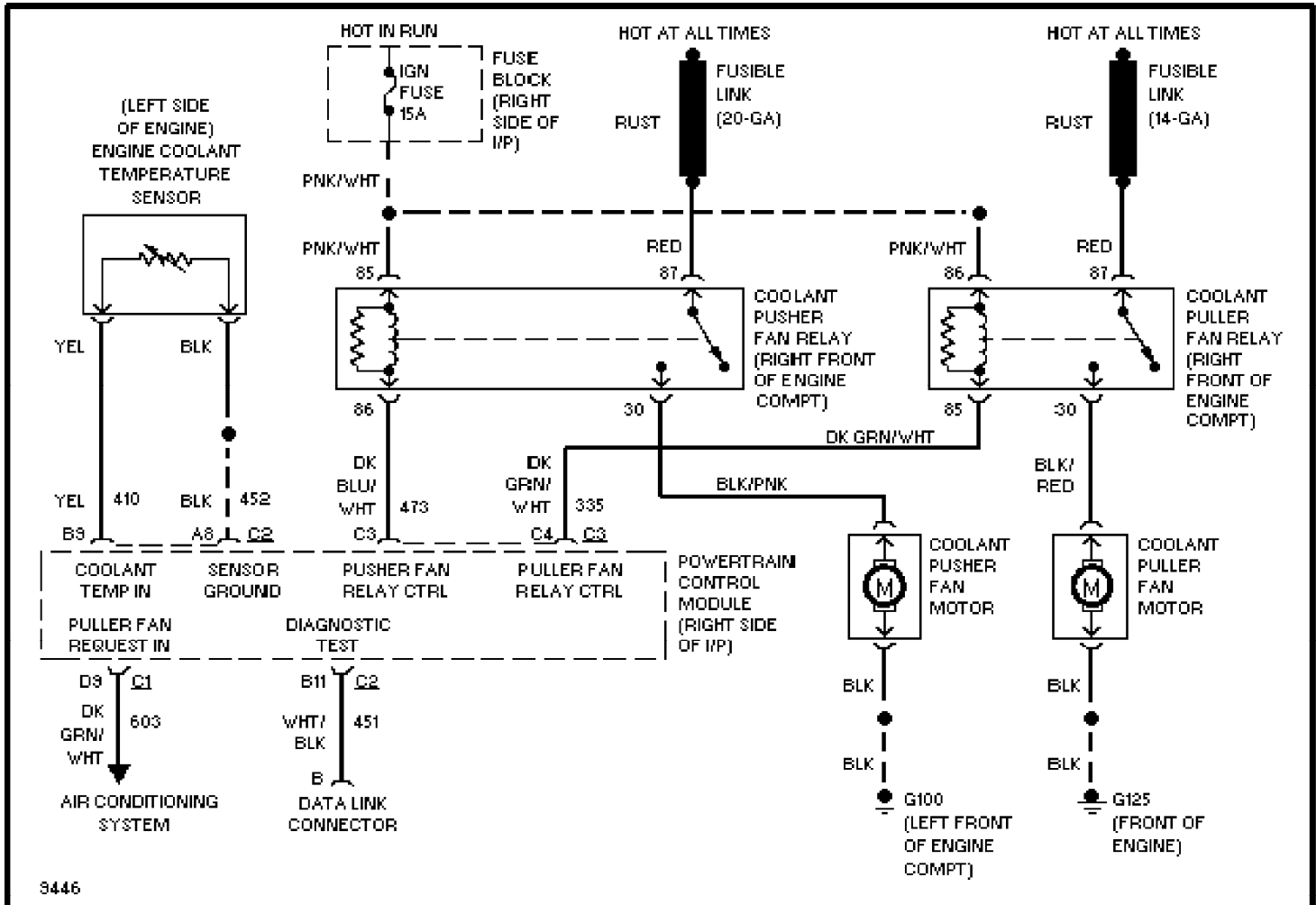

# SYSTEM WIRING DIAGRAMS

## Defogger Circuit (p. 4)

1993 Pontiac Trans Sport

For x

Copyright © 1998 Mitchell Repair Information Company, LLC

Friday, November 26, 2004 07:52AM

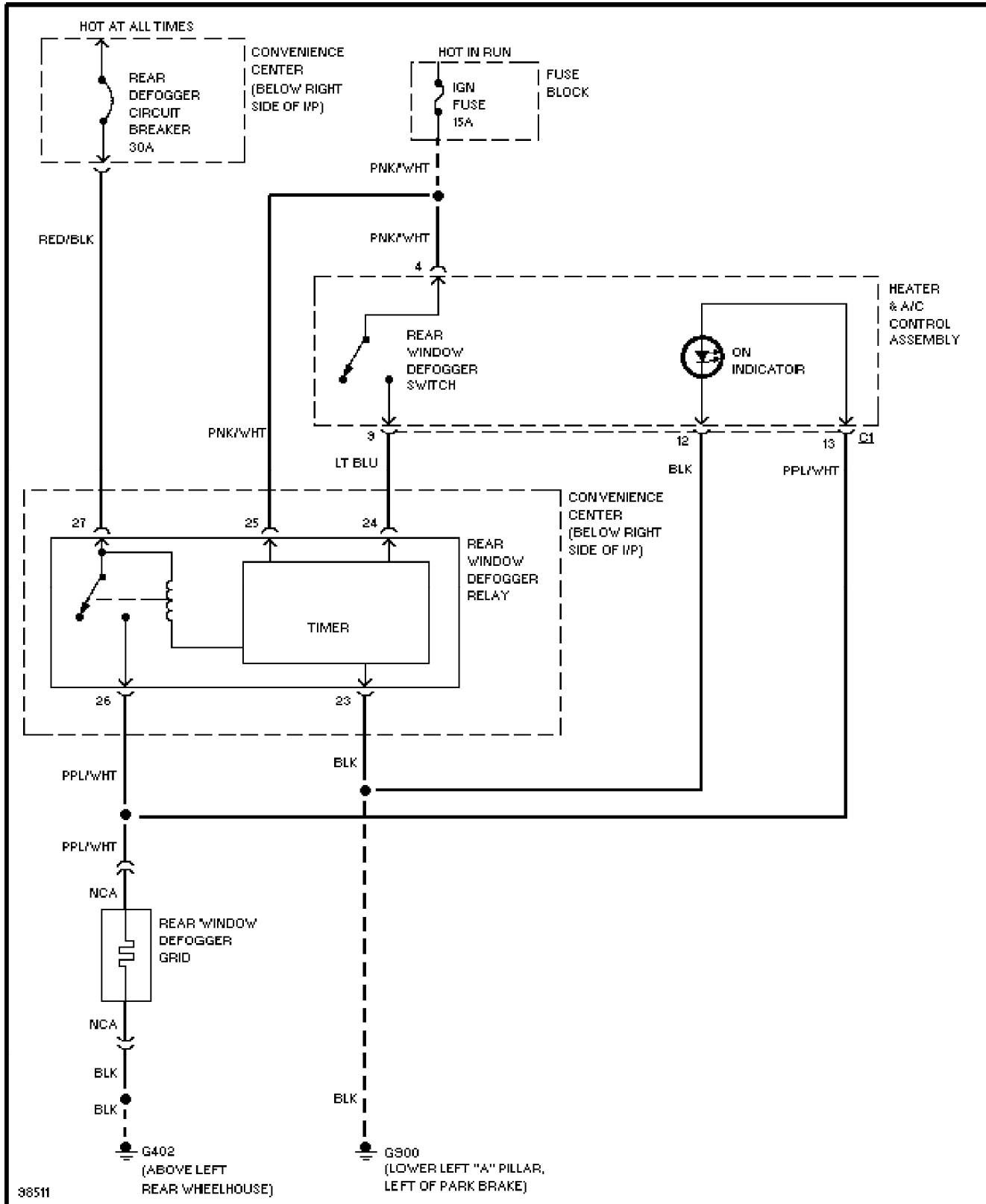

# SYSTEM WIRING DIAGRAMS

## Horn Circuit (p. 5)

1993 Pontiac Trans Sport

For x

Copyright © 1998 Mitchell Repair Information Company, LLC

Friday, November 26, 2004 07:52AM

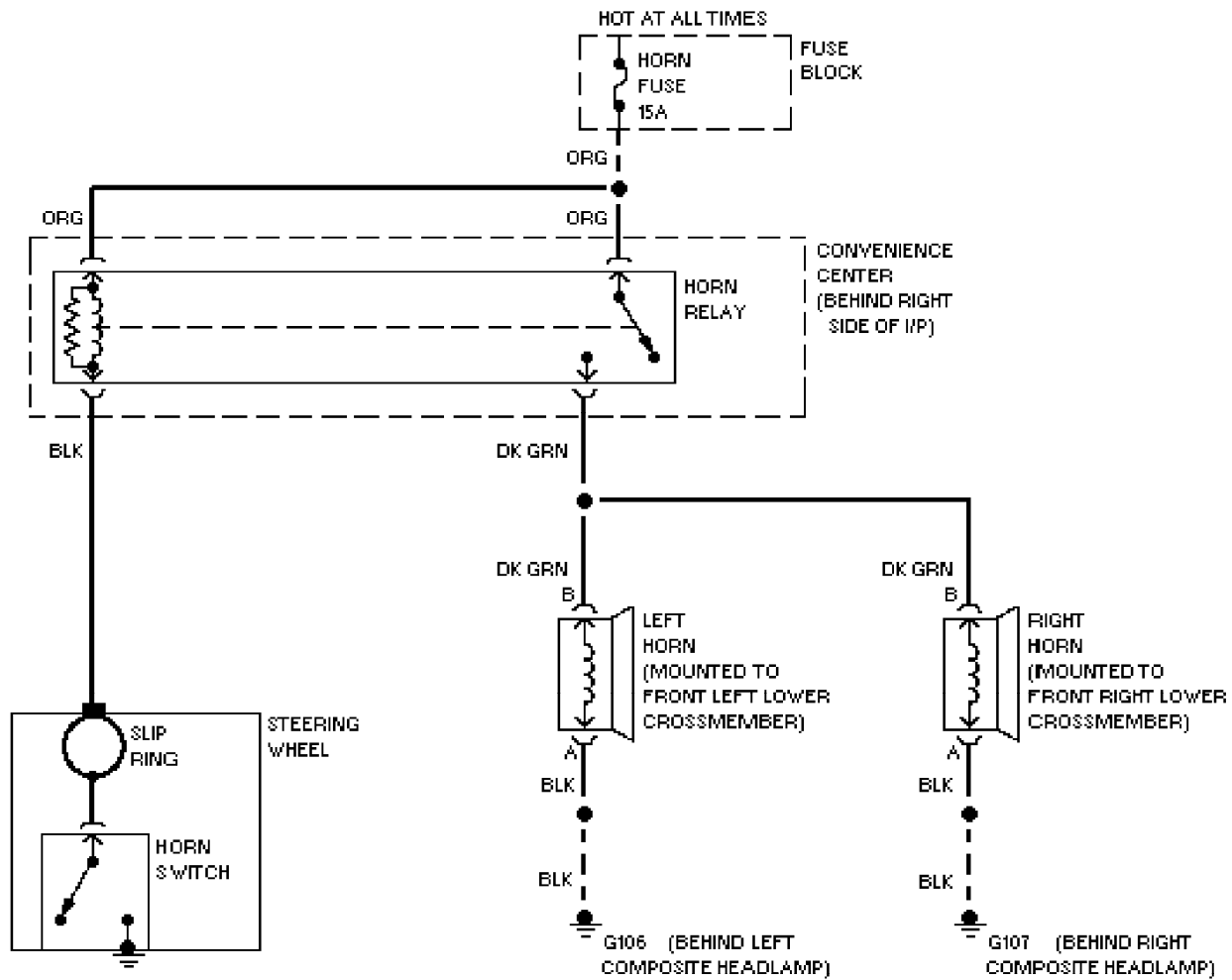

# SYSTEM WIRING DIAGRAMS

## Door Lock Circuit (p. 6)

1993 Pontiac Trans Sport

For x

Copyright © 1998 Mitchell Repair Information Company, LLC

Friday, November 26, 2004 07:52AM

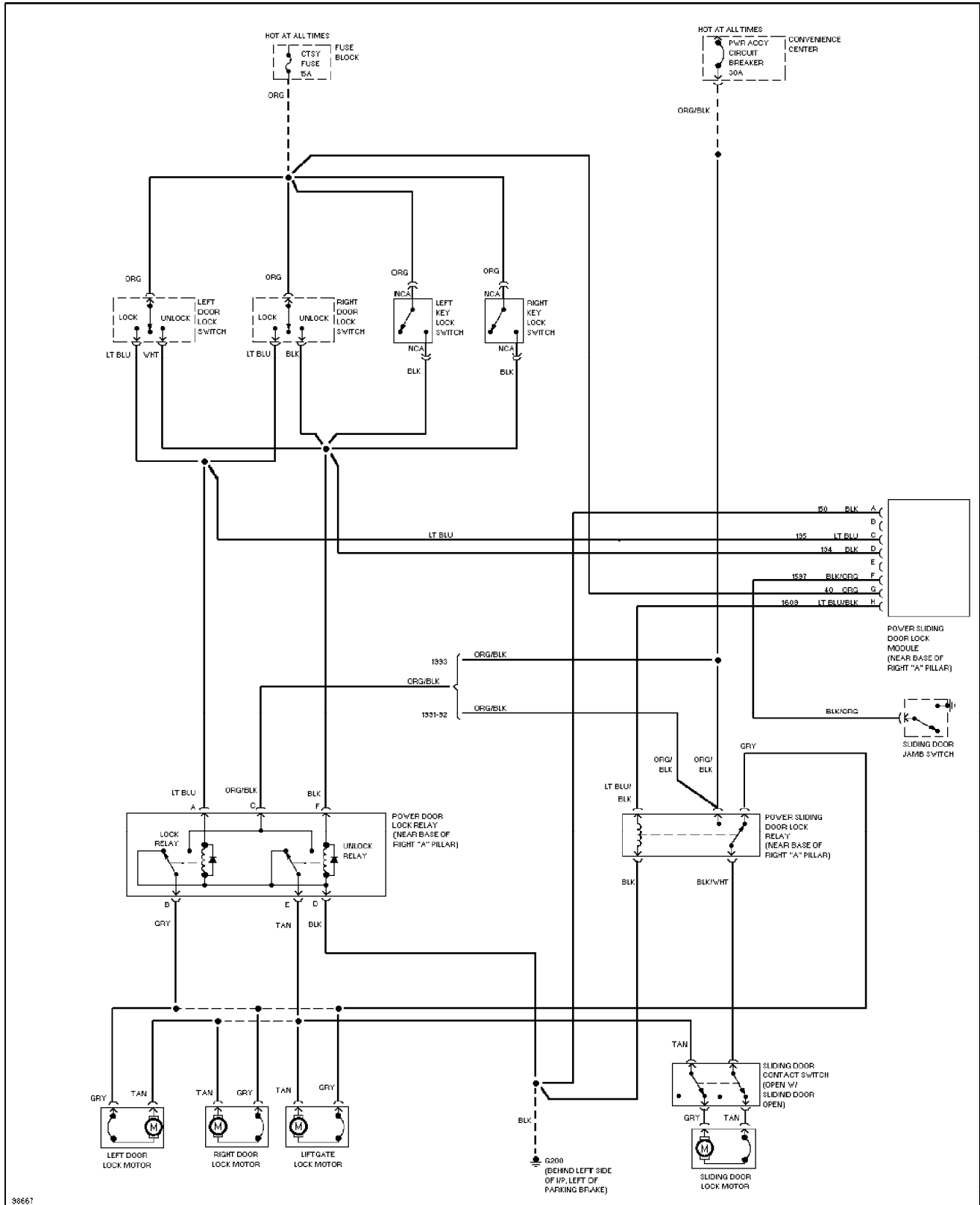







# SYSTEM WIRING DIAGRAMS

## 6-Way Power Seat Circuit (p. 9)

1993 Pontiac Trans Sport

For x

Copyright © 1998 Mitchell Repair Information Company, LLC

Friday, November 26, 2004 07:52AM

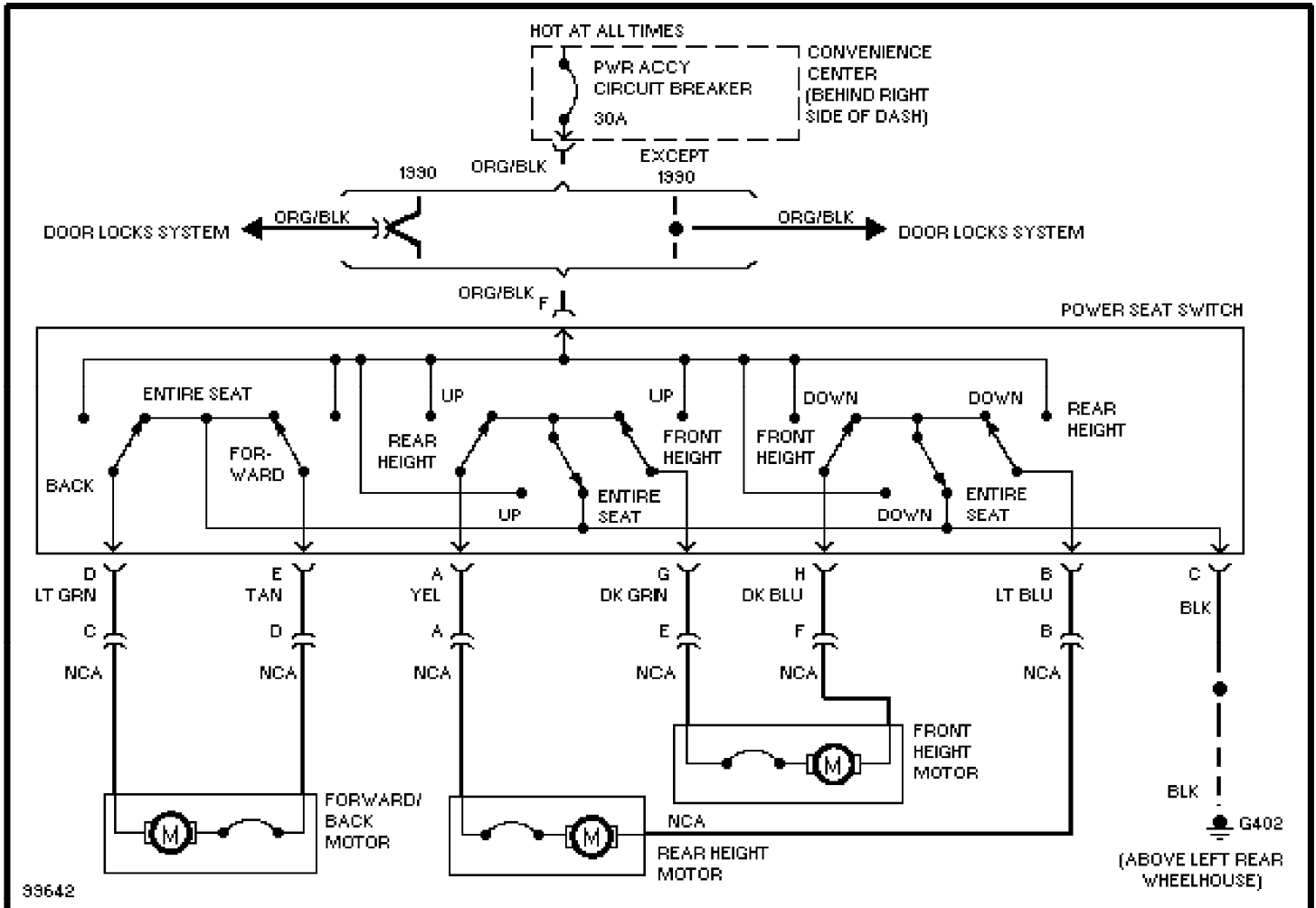

# SYSTEM WIRING DIAGRAMS

## Power Window Circuit (p. 10)

1993 Pontiac Trans Sport

For x

Copyright © 1998 Mitchell Repair Information Company, LLC

Friday, November 26, 2004 07:52AM

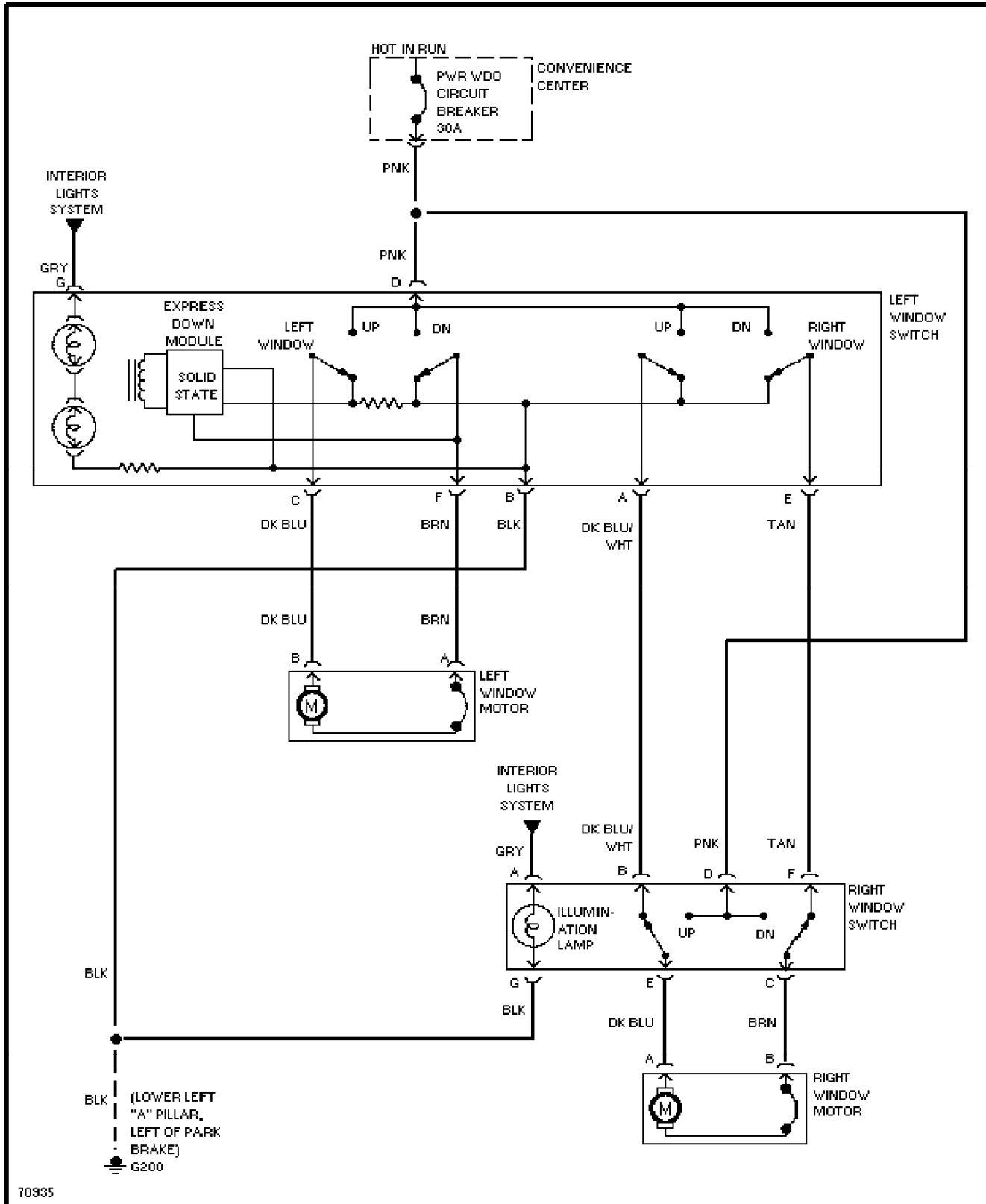

# SYSTEM WIRING DIAGRAMS

## Radio Circuits (p. 11)

1993 Pontiac Trans Sport

For x

Copyright © 1998 Mitchell Repair Information Company, LLC

Friday, November 26, 2004 07:52AM

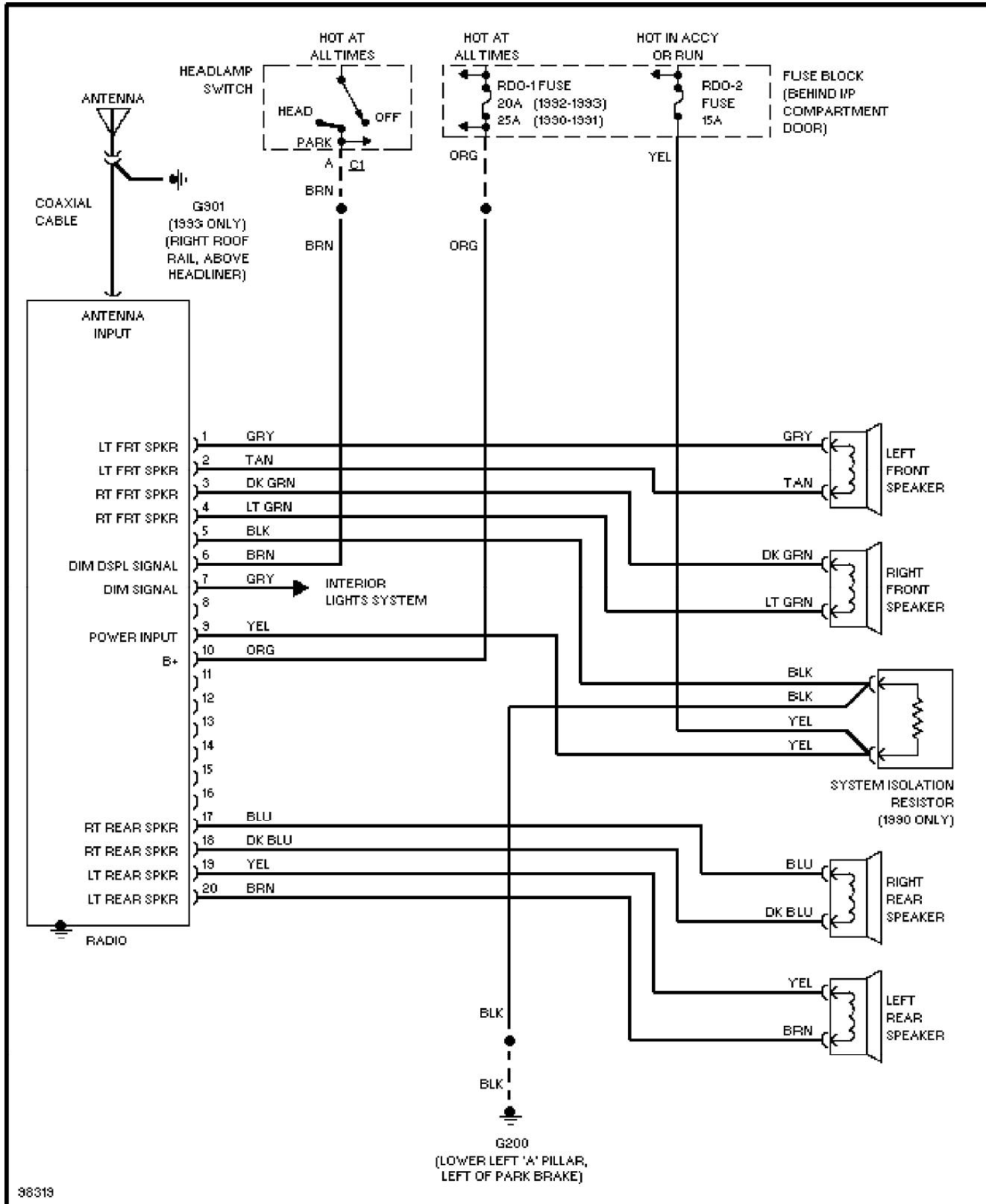

# SYSTEM WIRING DIAGRAMS

## Charging Circuit (p. 12)

1993 Pontiac Trans Sport

For x

Copyright © 1998 Mitchell Repair Information Company, LLC

Friday, November 26, 2004 07:52AM

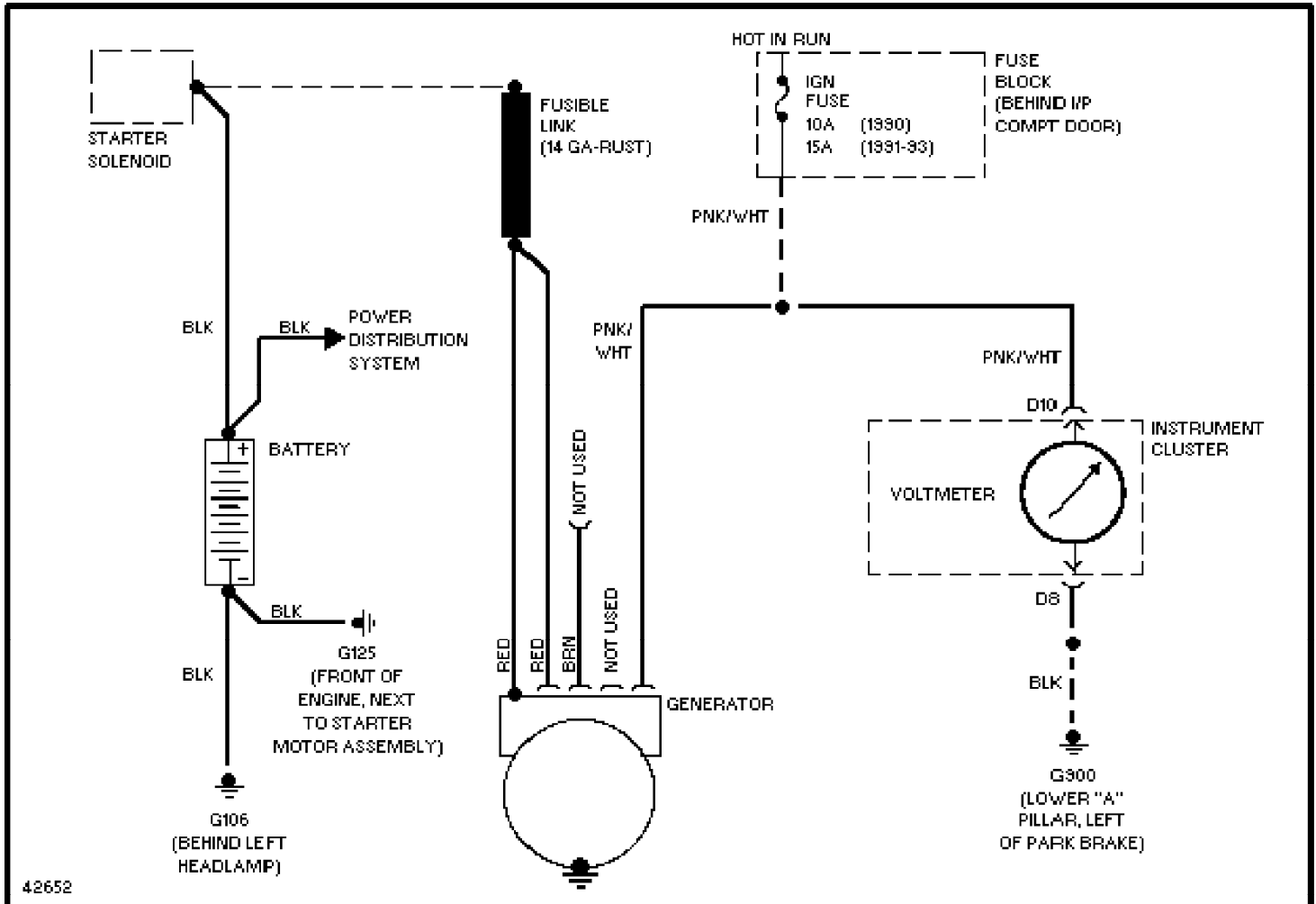

# SYSTEM WIRING DIAGRAMS

## Starting Circuit (p. 13)

1993 Pontiac Trans Sport

For x

Copyright © 1998 Mitchell Repair Information Company, LLC

Friday, November 26, 2004 07:52AM

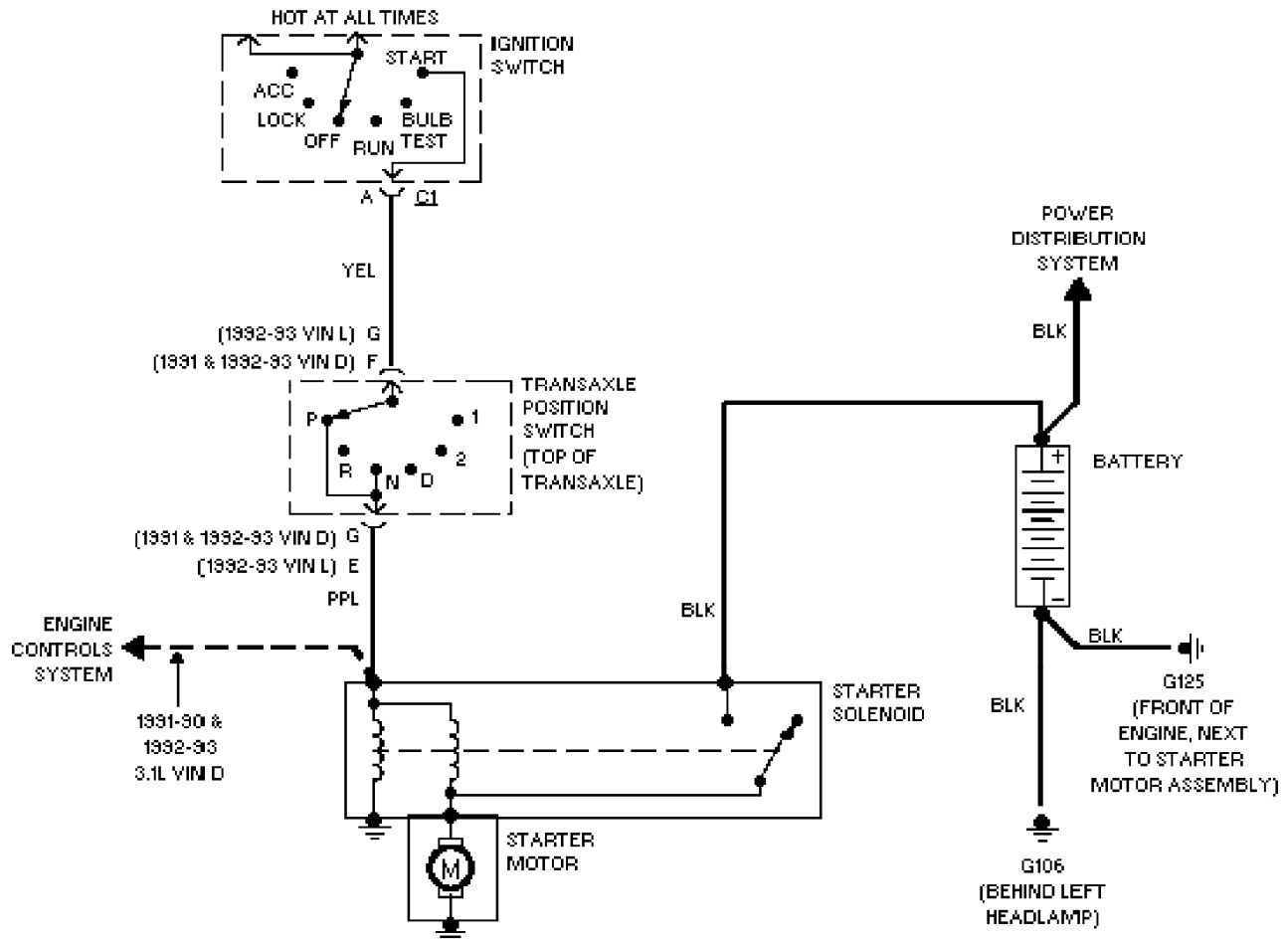

# SYSTEM WIRING DIAGRAMS

## Transmission Circuit, 4T60-E (p. 14)

1993 Pontiac Trans Sport

For x

Copyright © 1998 Mitchell Repair Information Company, LLC  
Friday, November 26, 2004 07:52AM

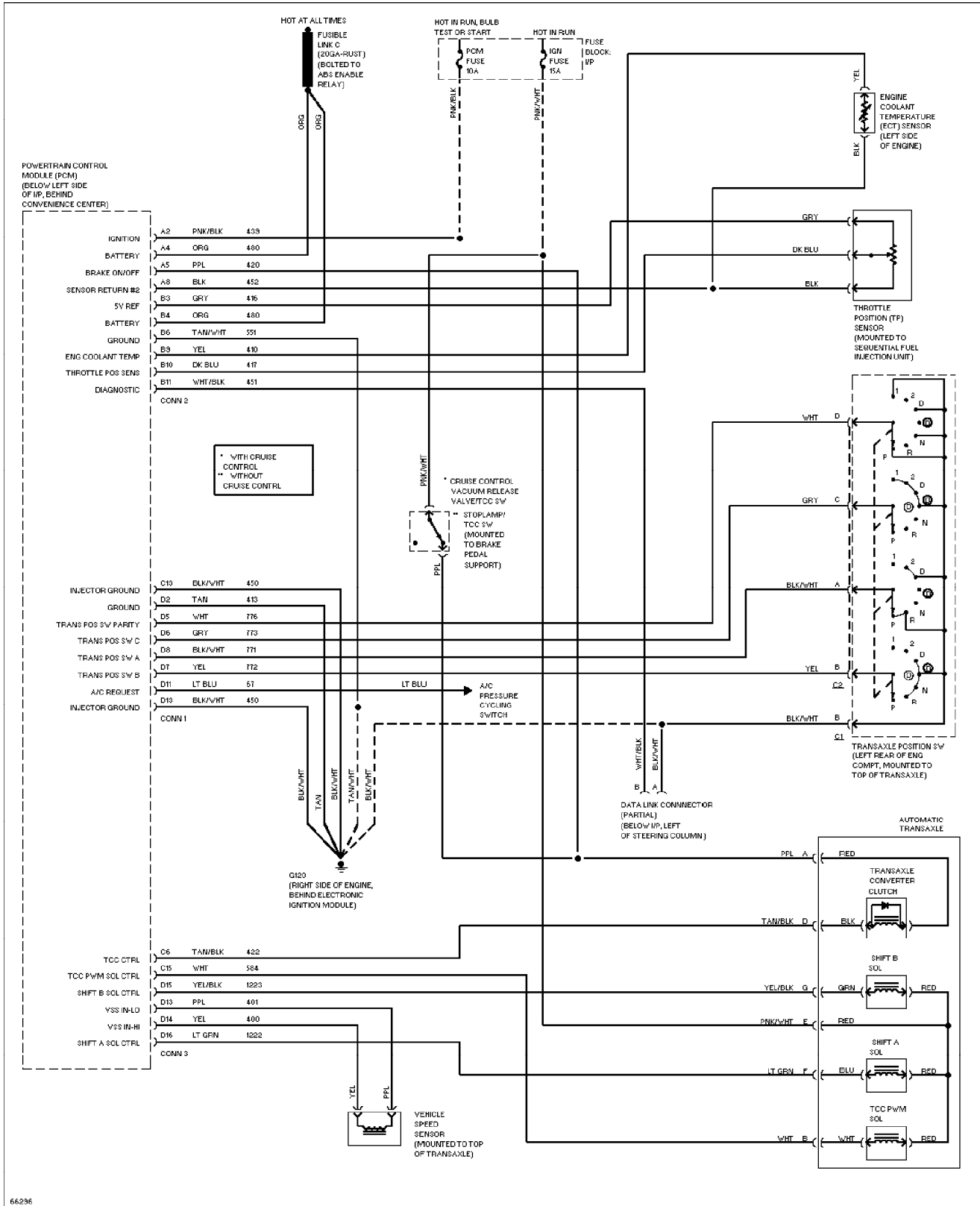

# SYSTEM WIRING DIAGRAMS

## Interval Wiper/Washer Circuit (p. 15)

1993 Pontiac Trans Sport

For x

Copyright © 1998 Mitchell Repair Information Company, LLC

Friday, November 26, 2004 07:52AM

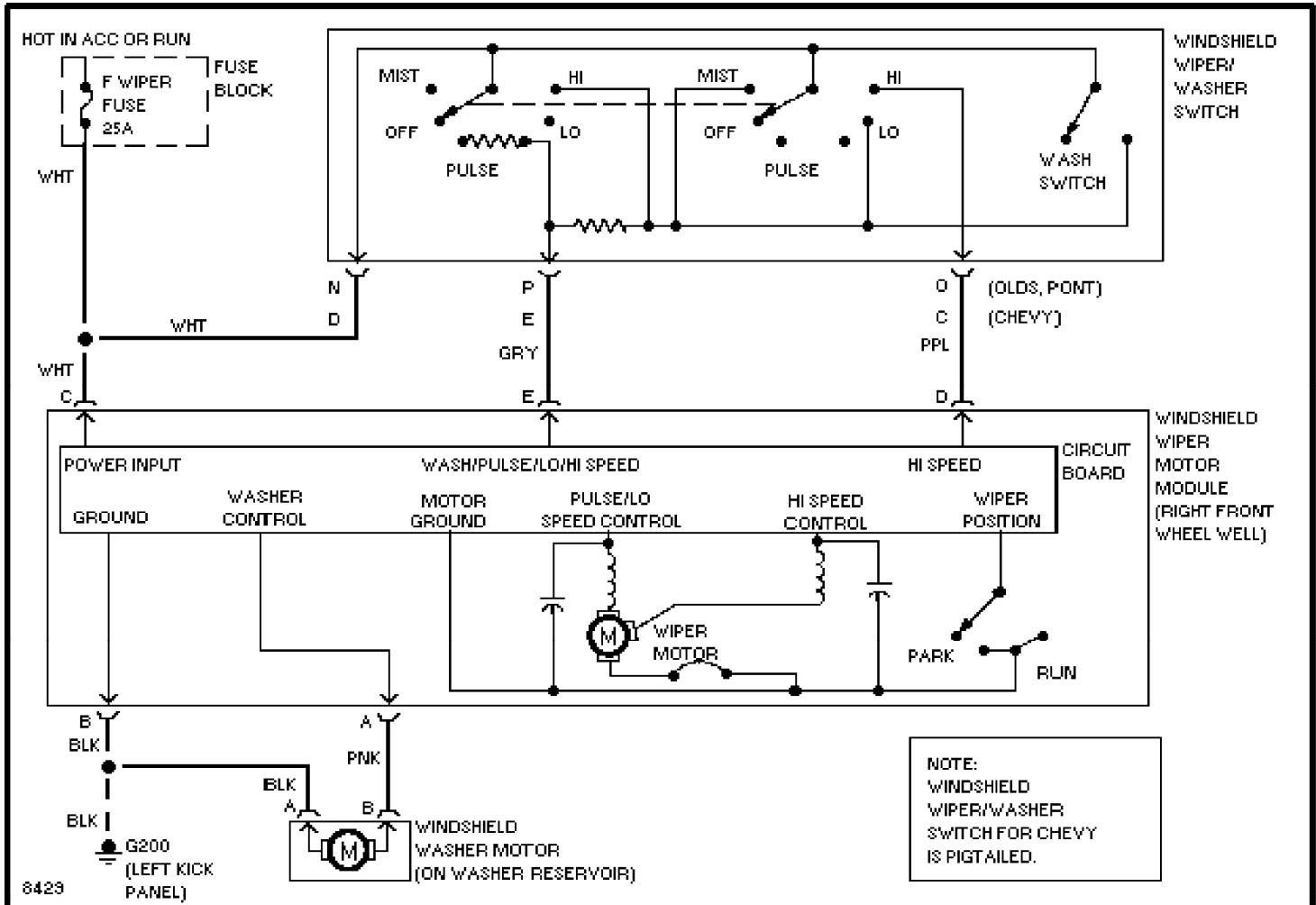

# SYSTEM WIRING DIAGRAMS

## Rear Wiper/Washer Circuit (p. 16)

1993 Pontiac Trans Sport

For x

Copyright © 1998 Mitchell Repair Information Company, LLC

Friday, November 26, 2004 07:52AM

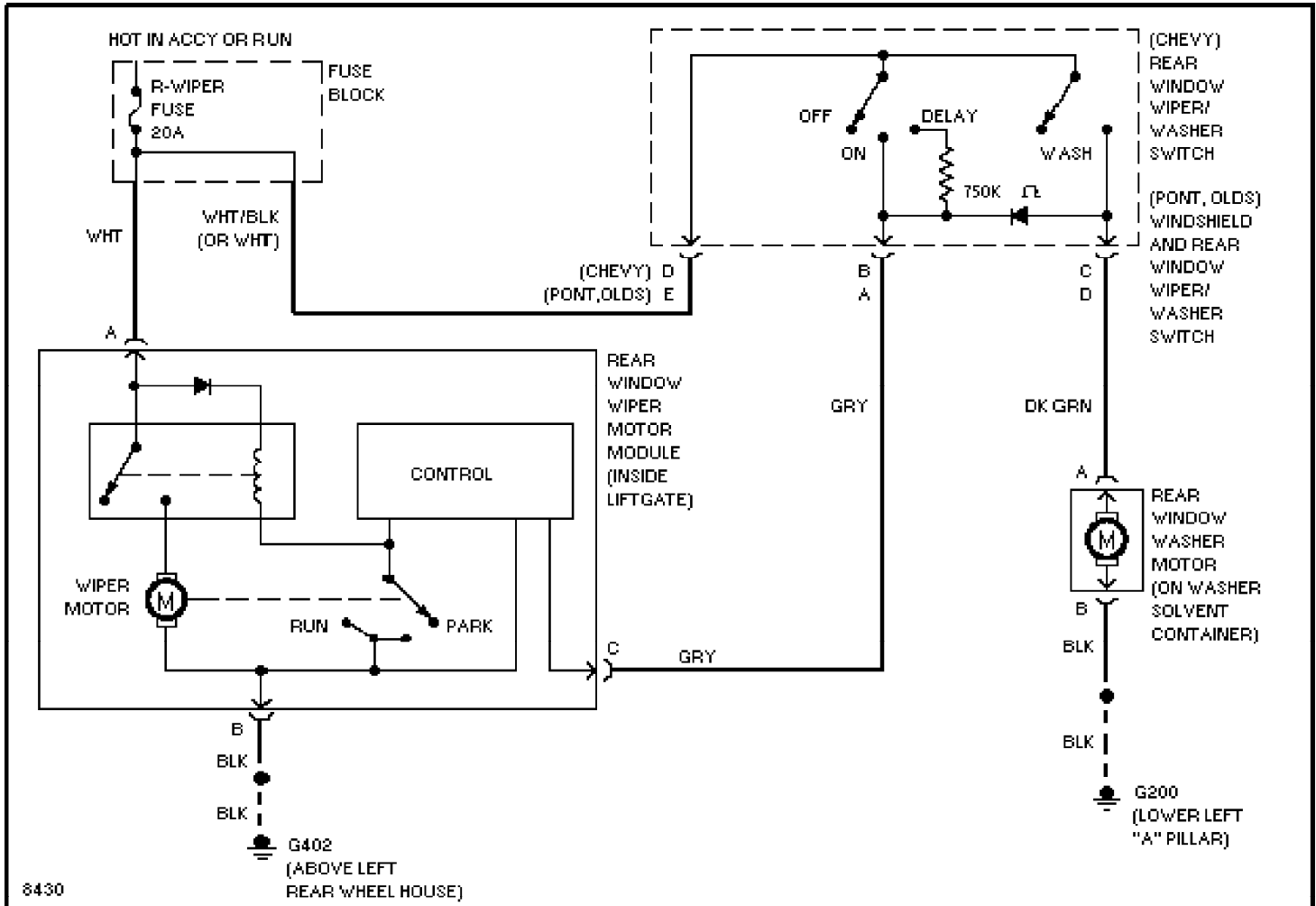



# WIRING DIAGRAMS

## Fig. 1: Engine Compartment & Headlights (Grids 1-3)

1993 Pontiac Trans Sport

For x

Copyright © 1998 Mitchell Repair Information Company, LLC

Friday, November 26, 2004 07:52AM

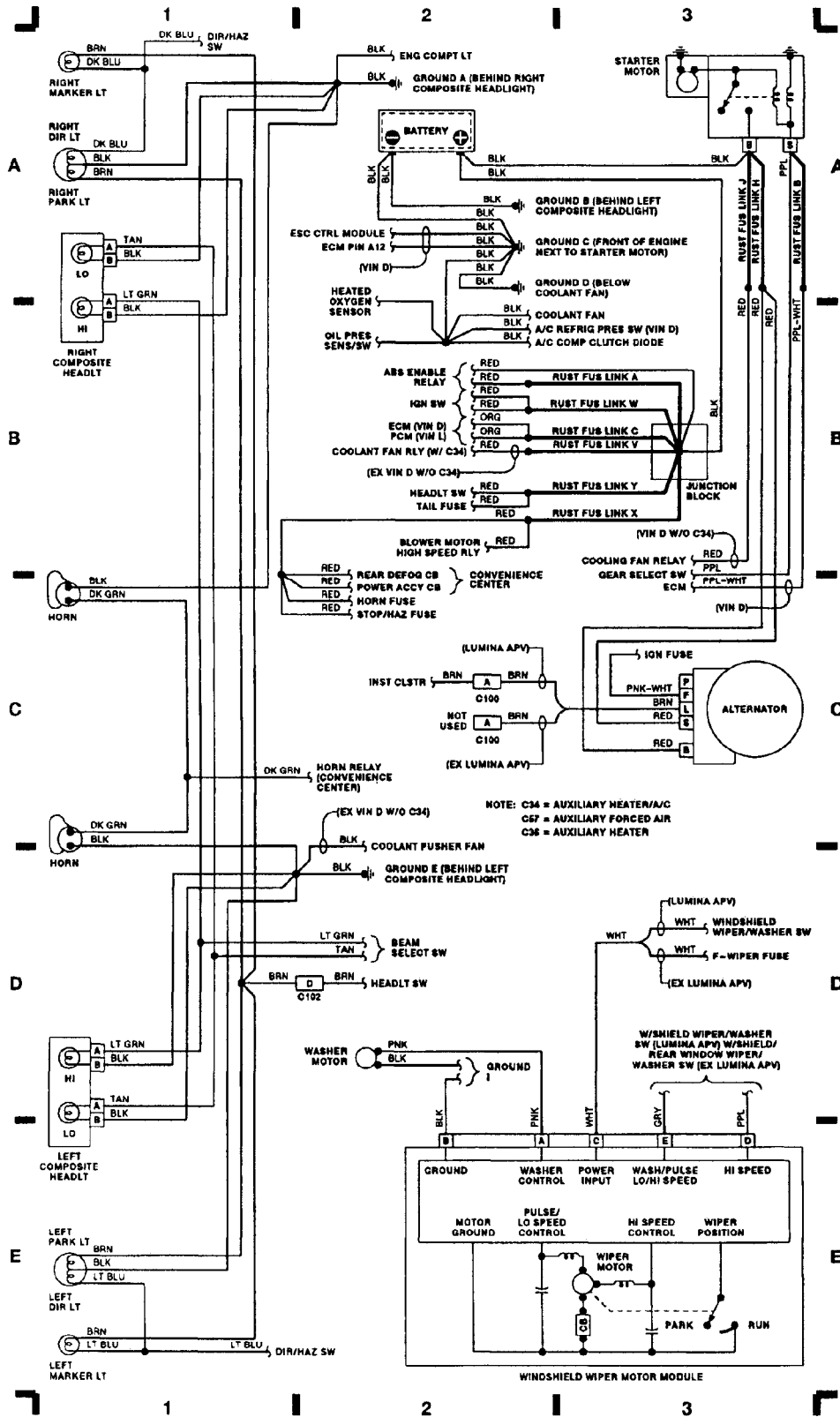





# WIRING DIAGRAMS

## Fig. 4: Cruise Control Servo, Sw, Fuel Pump Relay (Grids 12-15) (p. 4)

1993 Pontiac Trans Sport

For x

Copyright © 1998 Mitchell Repair Information Company, LLC

Friday, November 26, 2004 07:52AM

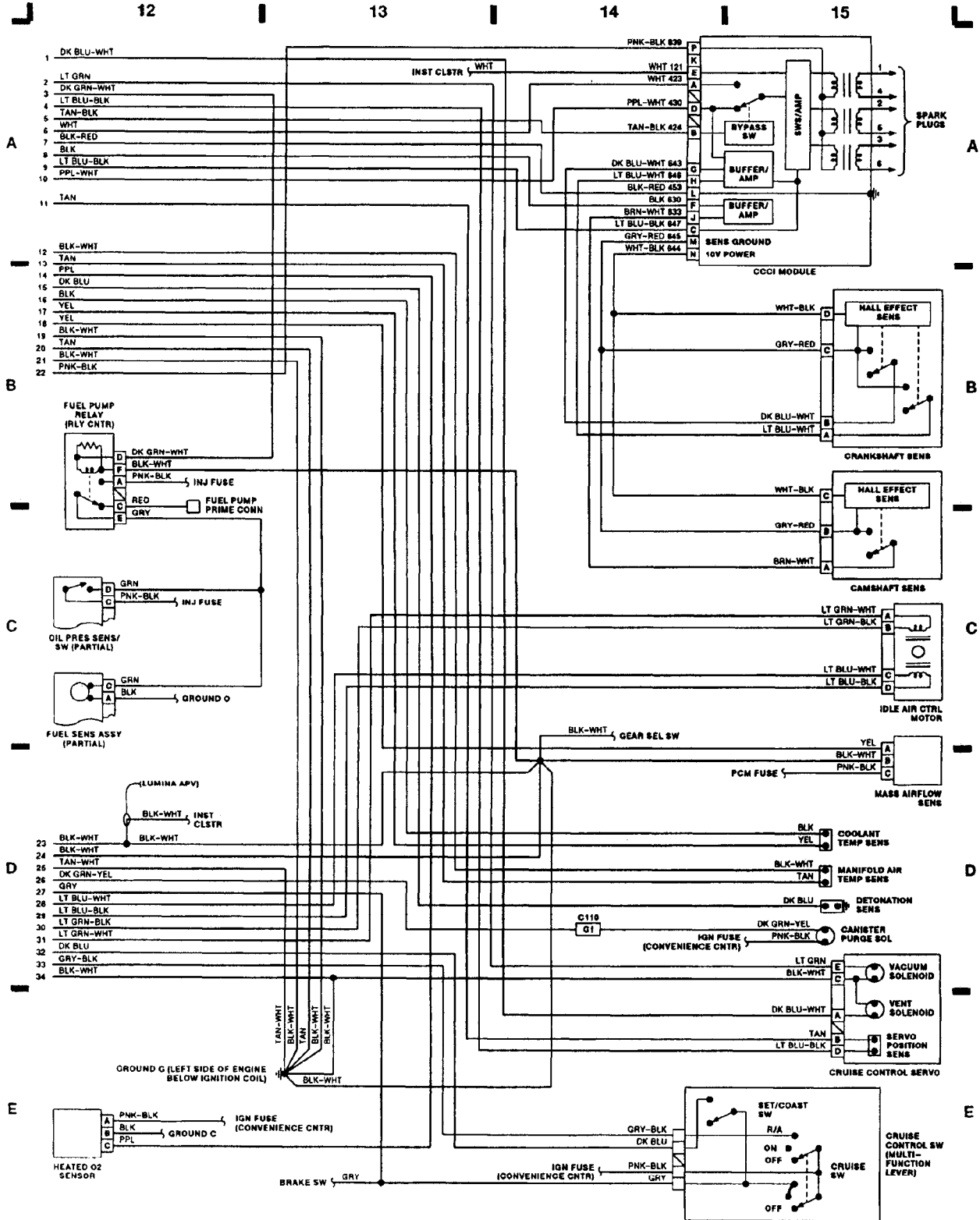

# WIRING DIAGRAMS

## Fig. 5: Fuse Block, VIN L, VIN D (Grids 16-19) (p. 5)

### 1993 Pontiac Trans Sport

For x  
Copyright © 1998 Mitchell Repair Information Company, LLC  
Friday, November 26, 2004 07:52AM

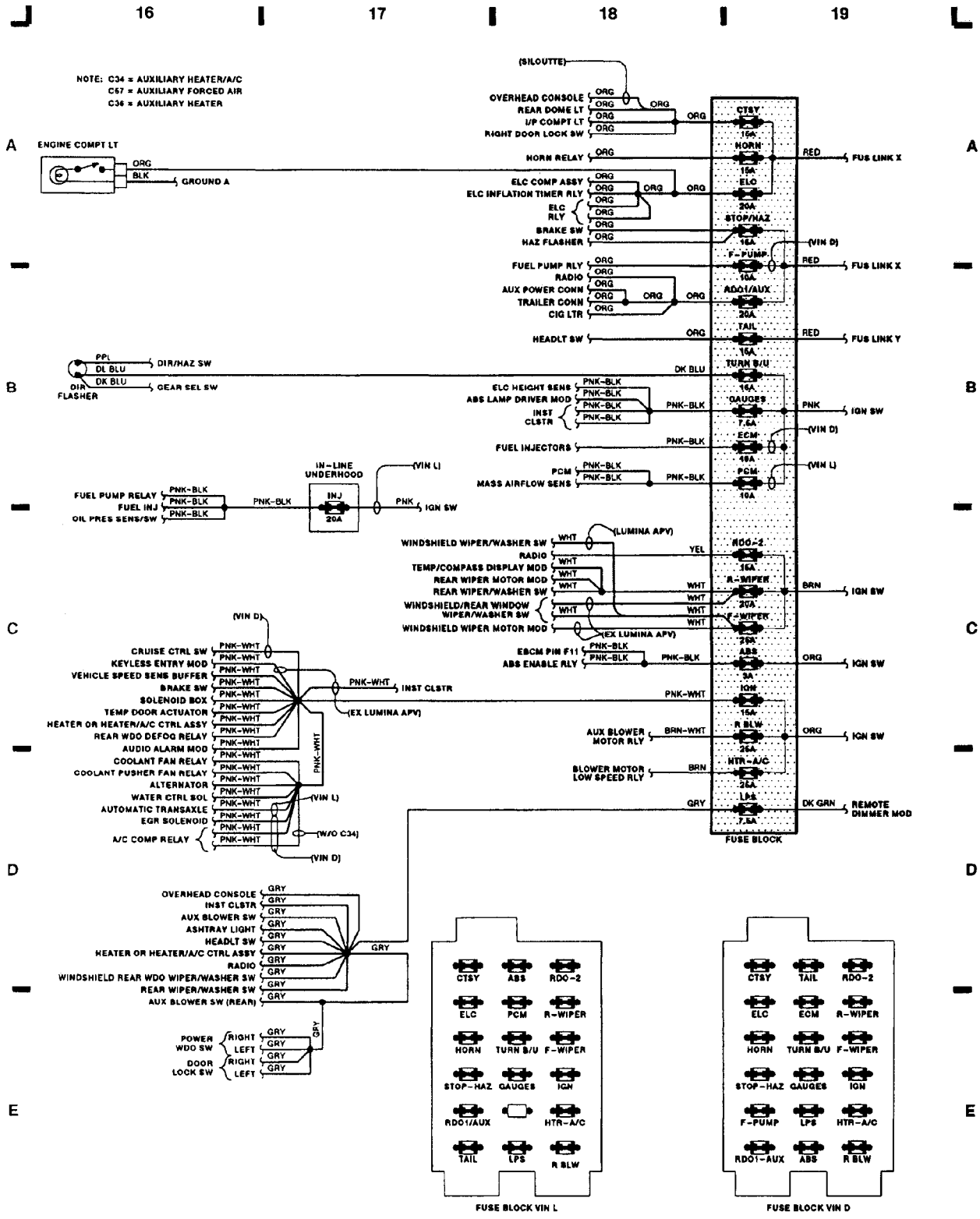

# WIRING DIAGRAMS

## Fig. 6: Ignition Switch, Gear Sel Sw (Grids 20-23) (p. 6)

1993 Pontiac Trans Sport

For x

Copyright © 1998 Mitchell Repair Information Company, LLC

Friday, November 26, 2004 07:52AM

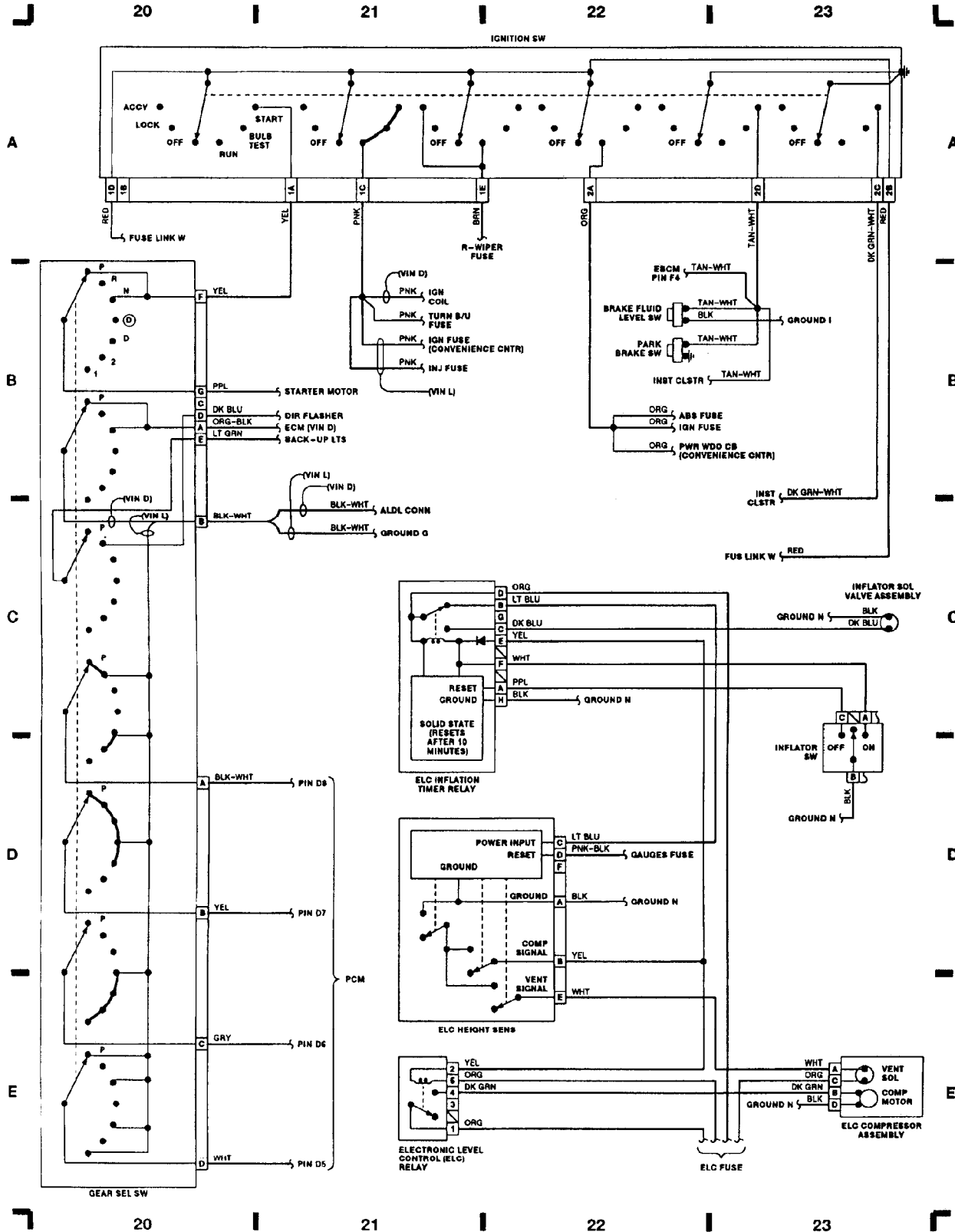

# WIRING DIAGRAMS

## Fig. 7: Electronic Brake Control MOD (Grids 24-27) (p. 7)

### 1993 Pontiac Trans Sport

For x  
Copyright © 1998 Mitchell Repair Information Company, LLC  
Friday, November 26, 2004 07:52AM

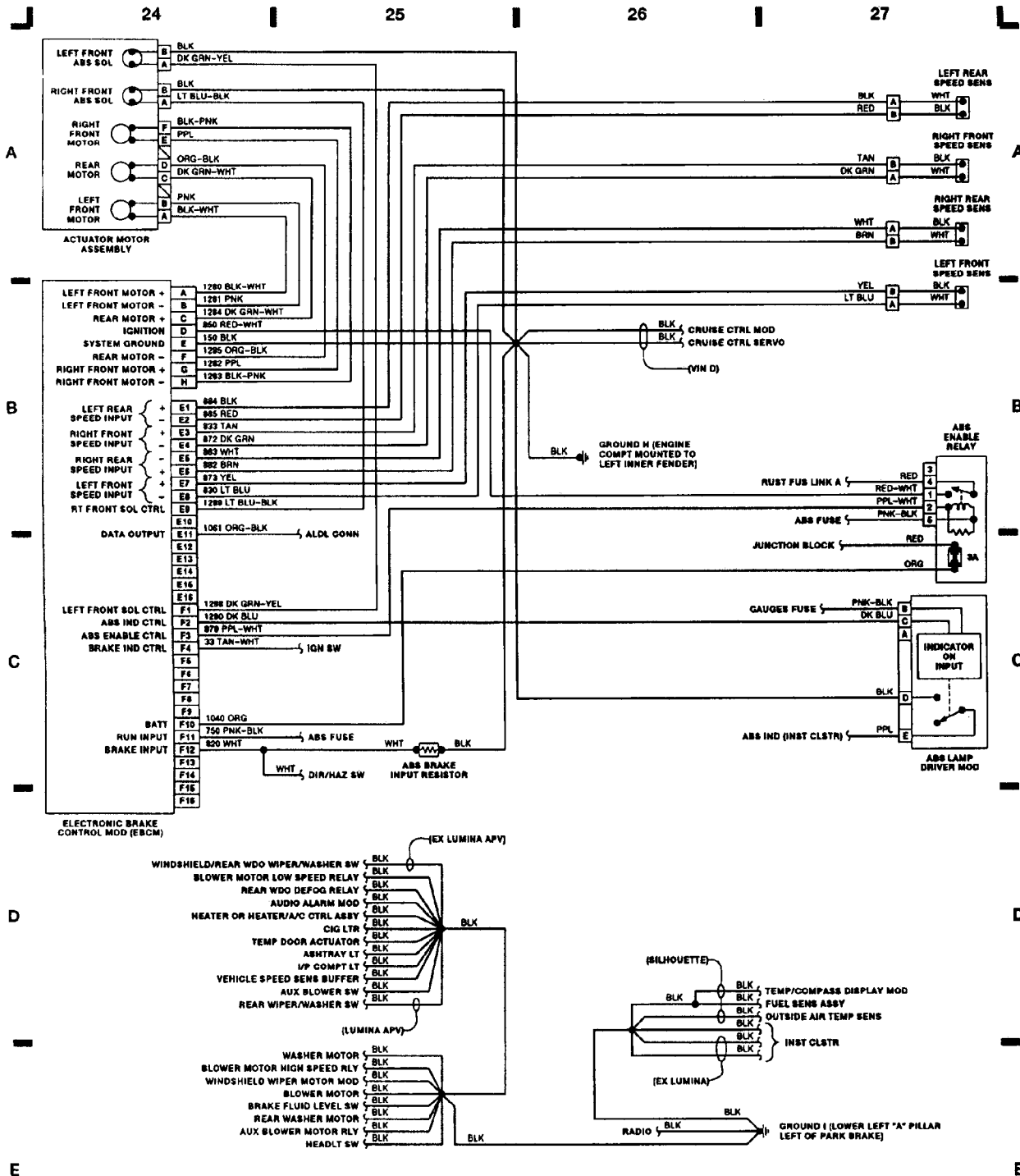

# WIRING DIAGRAMS

## Fig. 8: Heater/A/C Control Assembly (Grids 28-31) (p. 8)

1993 Pontiac Trans Sport

For x

Copyright © 1998 Mitchell Repair Information Company, LLC

Friday, November 26, 2004 07:52AM

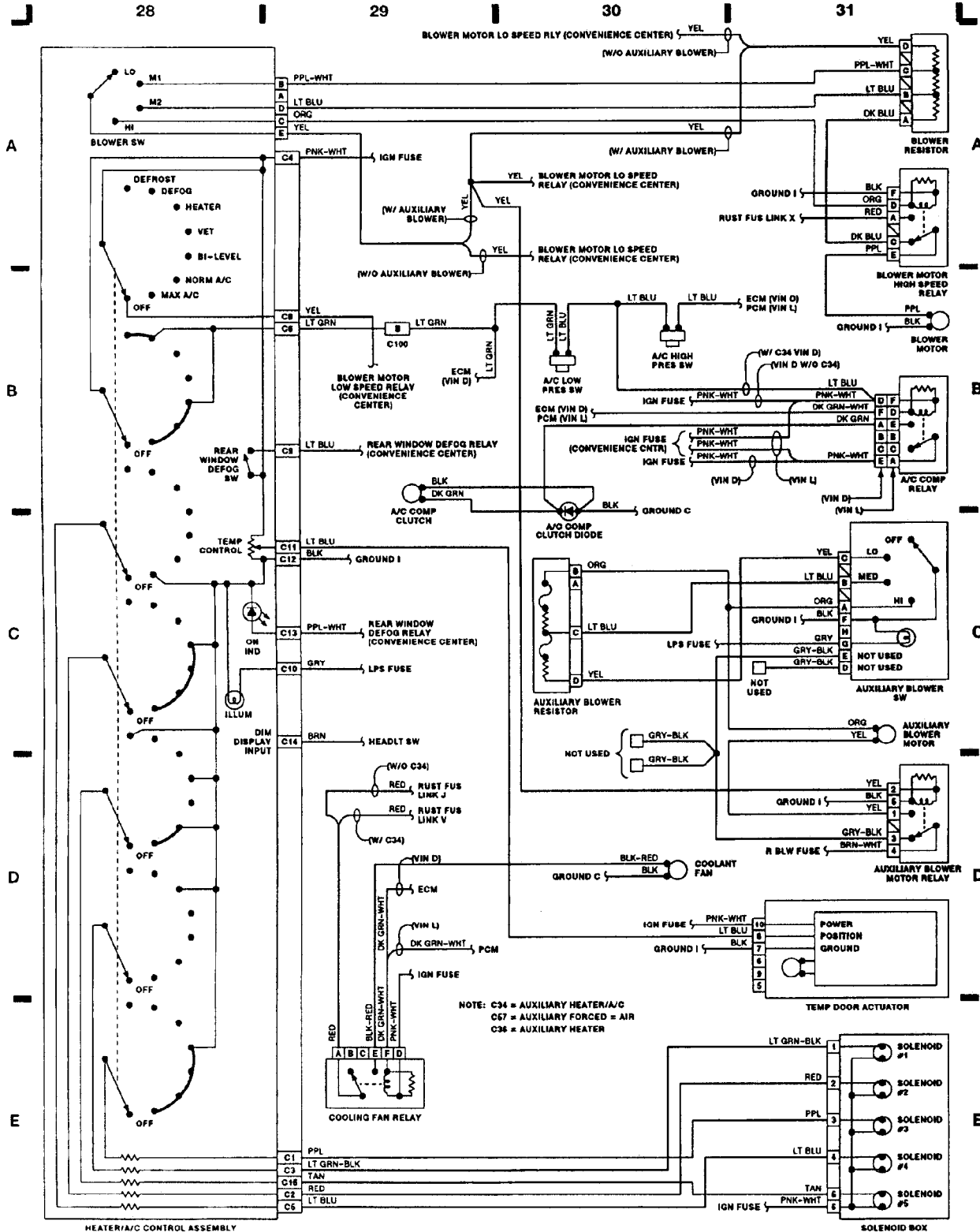





# WIRING DIAGRAMS

## Fig. 10: Convenience Center, Dir/Haz Sw (Grids 36-39) (p. 10)

1993 Pontiac Trans Sport

For x

Copyright © 1998 Mitchell Repair Information Company, LLC

Friday, November 26, 2004 07:52AM

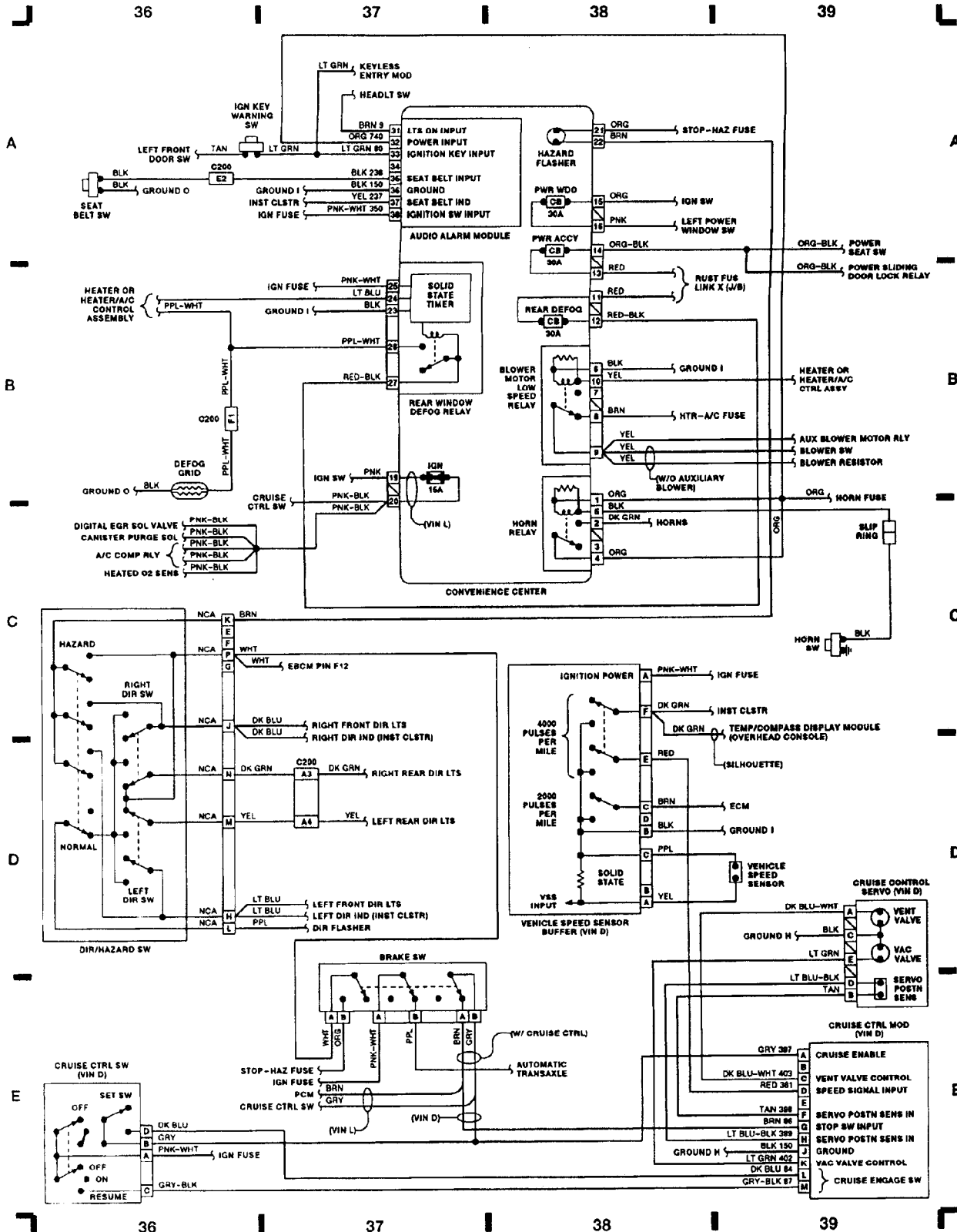

# WIRING DIAGRAMS

## Fig. 11: Headlt Sw, W/Shield Wiper/Washer Sw (Grids 40-43) (p. 11)

1993 Pontiac Trans Sport

For x

Copyright © 1998 Mitchell Repair Information Company, LLC

Friday, November 26, 2004 07:52AM

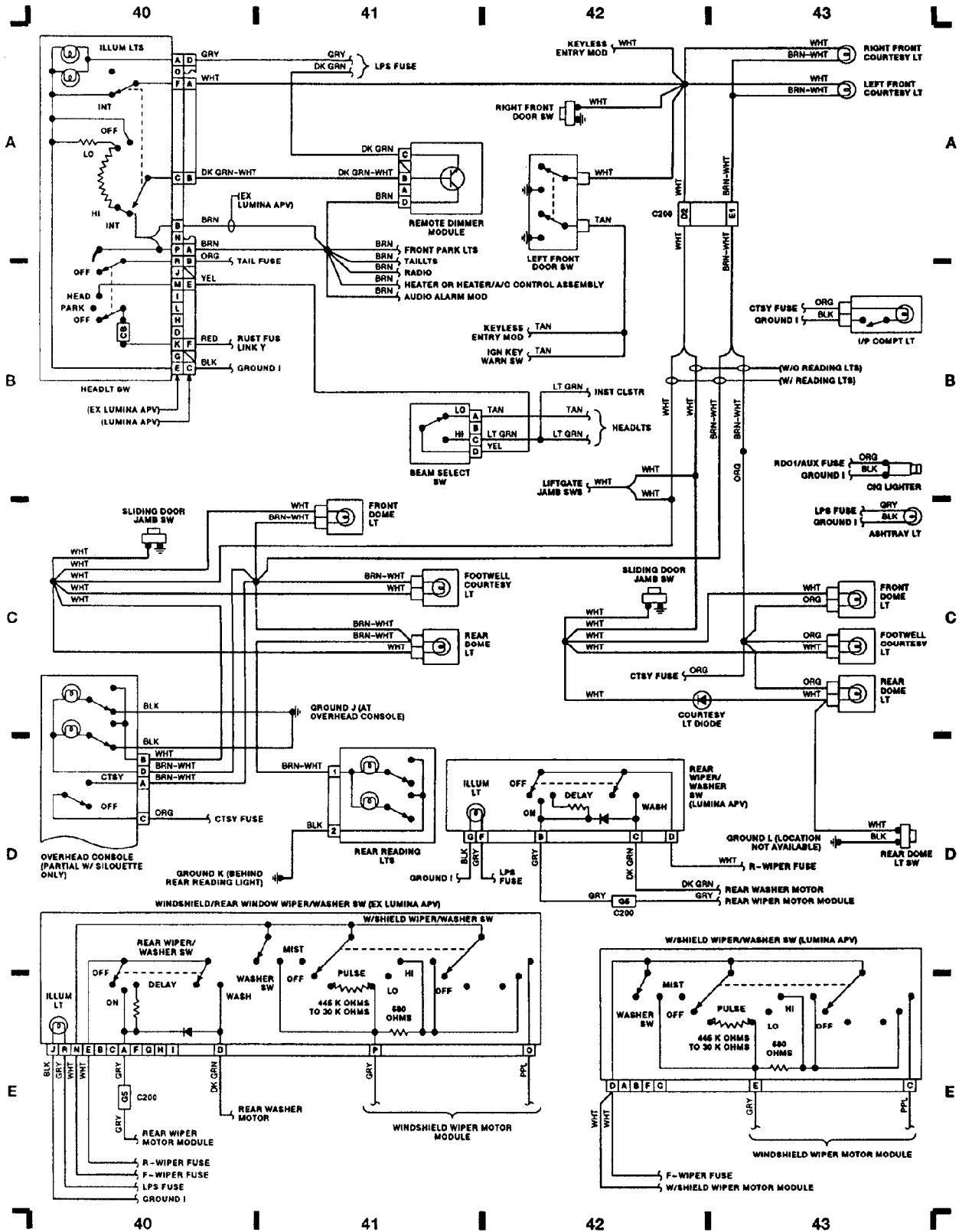

# WIRING DIAGRAMS

## Fig. 12: Instrument Cluster, Mirror Switches (Grids 44-47) (p. 12)

1993 Pontiac Trans Sport

For x

Copyright © 1998 Mitchell Repair Information Company, LLC

Friday, November 26, 2004 07:52AM

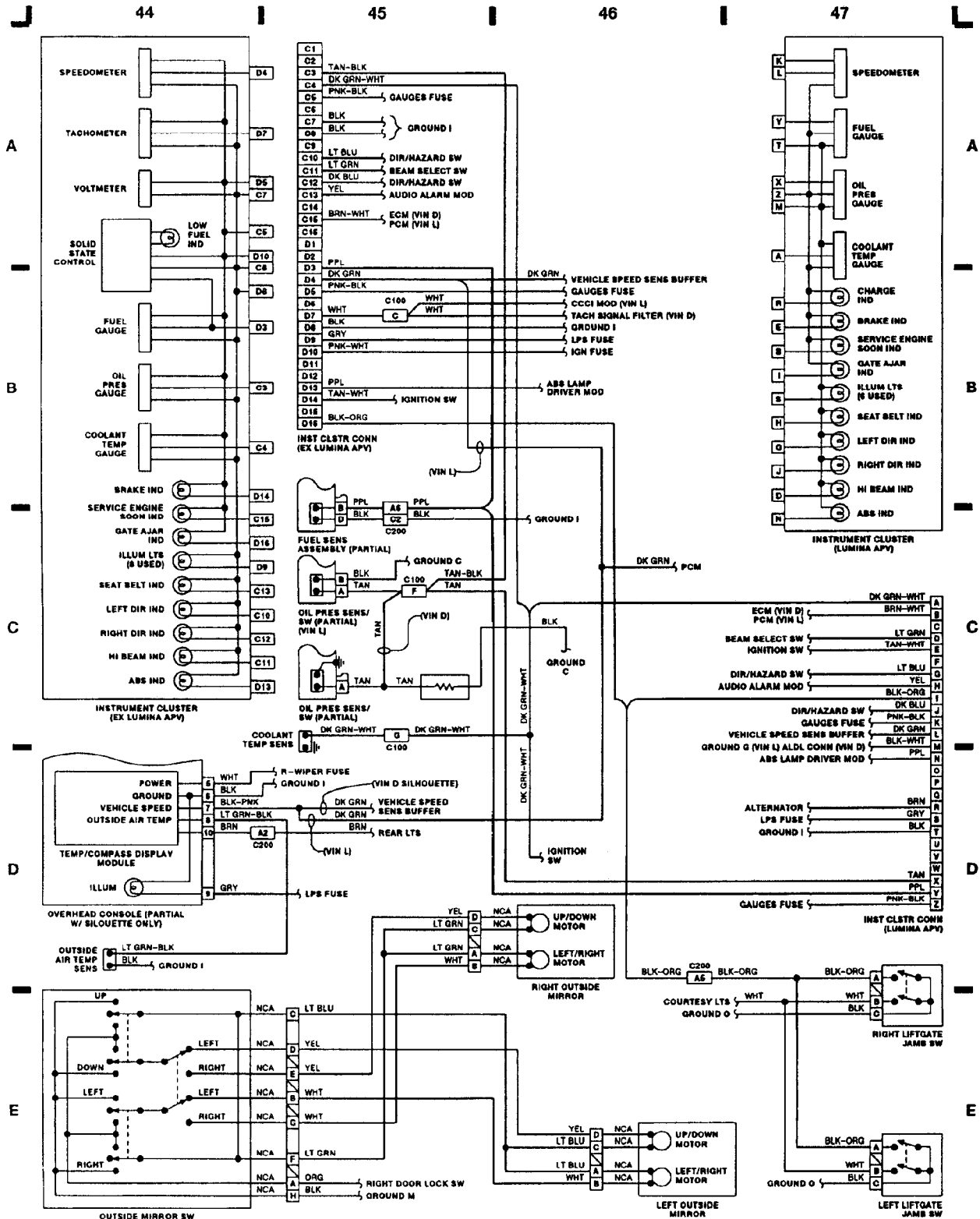

# WIRING DIAGRAMS

## Fig. 13: Keyless Entry Mod, Power Doors (Grids 48-51) (p. 13)

1993 Pontiac Trans Sport

For x

Copyright © 1998 Mitchell Repair Information Company, LLC

Friday, November 26, 2004 07:52AM

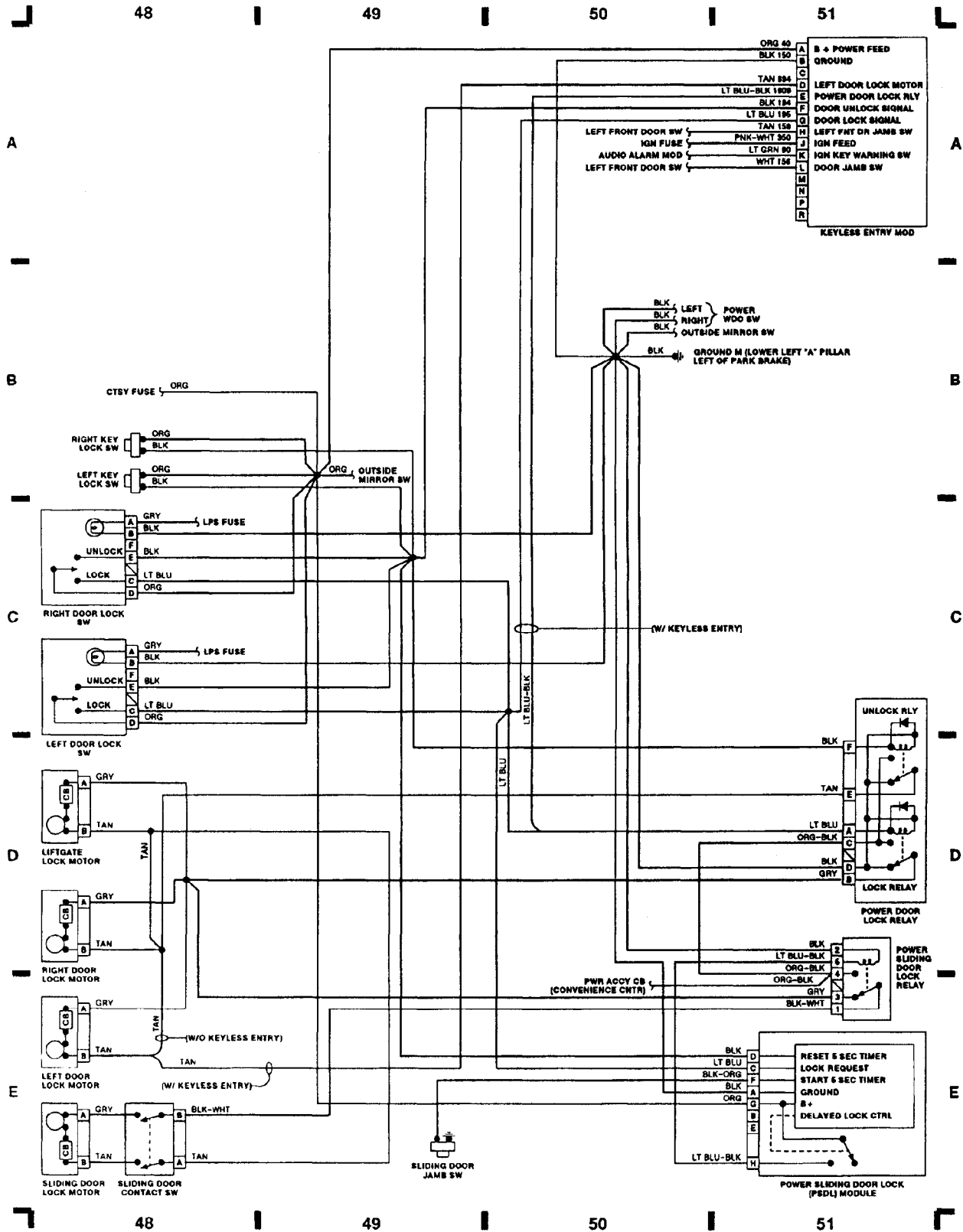

# WIRING DIAGRAMS

## Fig. 14: Power Seat Sw, Window Sw, Taillights (Grids 52-55) (p. 14)

1993 Pontiac Trans Sport

For x

Copyright © 1998 Mitchell Repair Information Company, LLC

Friday, November 26, 2004 07:52AM

