

net

Price 2/6

**THE**  
**OPERATION INSTRUCTIONS**  
**FOR THE**  
**10/40 H.P. & 12/48 H.P.**

**WOLSELEY MOTORS LTD.**

*Chairman:* Lord Nuffield

HEAD OFFICE:

**WARD END, BIRMINGHAM. 8**

Telegrams: "Exactitude, Telex, Birmingham" Telephone: East 1501

Telex Telephone: East Telex 0404

**LONDON DISTRIBUTORS: EUSTACE ACE WATKINS LTD.**

**Manor Street, Chelsea. S.W.3**

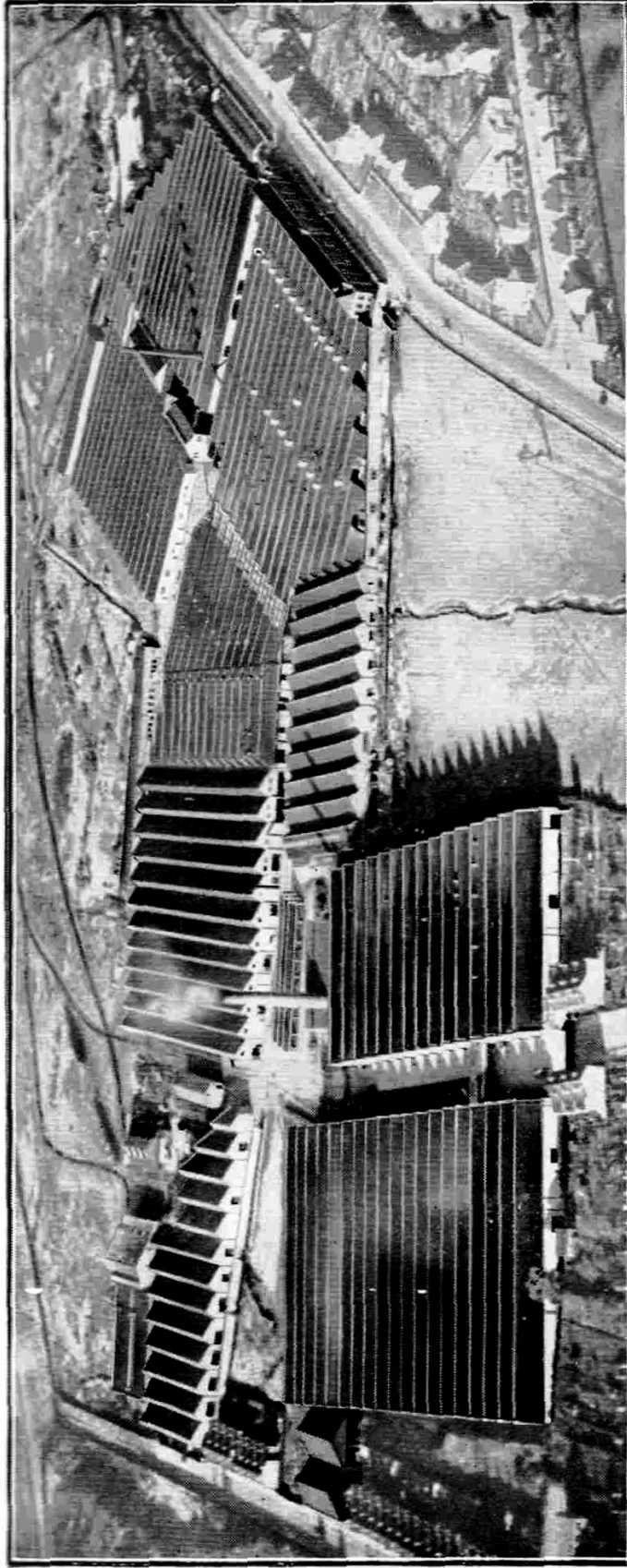

The Wolseley Works at Ward End, Birmingham, where some 7000 British craftsmen are employed.

~~~~~The Operation Instructions for the~~~~~

## **WOLSELEY 10/40 H.P. & 12/48 H.P.**

~~~~~

### **FILLING UP**

#### **Petrol**

THE quantity of petrol in the tank is indicated on the graduated scale at the left-hand side of the centre instrument panel **when the ignition is switched on**. The petrol tank is mounted on the rear of the chassis and has an accessible filler. The tank capacity of the Wolseley 10/40 and 12/48 is seven gallons.

Any first quality petrol, benzole mixture or alcohol mixture will give satisfactory results with the Wolseley 10/40 and 12/48.

#### **Oil**

Before starting see that there is an adequate supply of oil in the engine sump. The quantity present may be checked by means of the dipper rod indicator which projects from a boss on the near-side of the engine cylinder block. See that the engine is switched off and that the car is on level ground, then withdraw the dipper rod, wipe the oil on its lower end, reinsert it and again withdraw it. A certain amount of oil will be found adhering to the lower end of the rod, giving an indication of the actual oil level in the sump. If the oil level is below the " normal " mark the sump should be replenished through the filling orifice in the forward end of the cylinder head cover. The oil level should never be allowed to drop to the low mark.

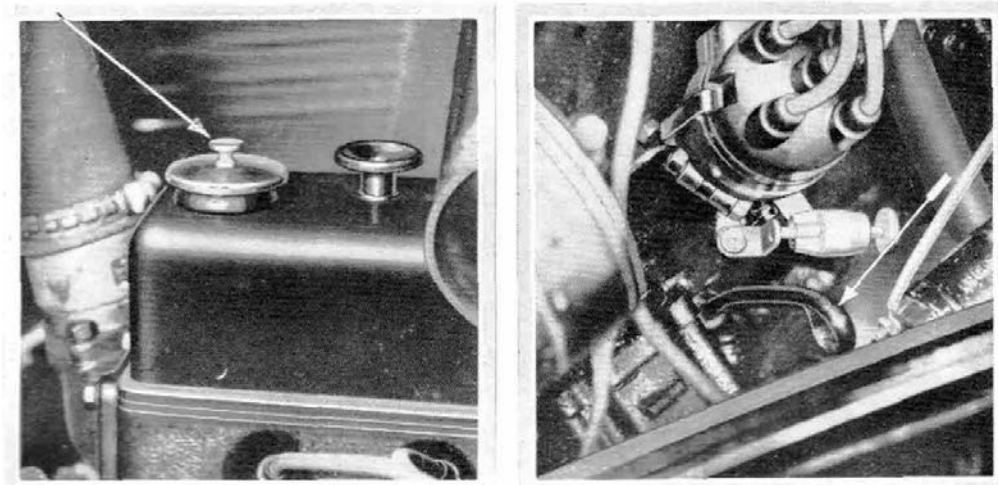

When filling up with oil, it is of the utmost importance to use perfectly clean oil and for this reason oil bought in sealed tins is to be preferred. Wolseley Motors Ltd. cannot hold themselves responsible under guarantee for crankshafts or bearings that are damaged or scored as a result of the use of dirty oil.

Wolseley Motors strongly advise the use of Morrisol " Sirrom " (Regd.) Brand Engine Oil for use in the Wolseley 10/40 and 12/48. Do not mix oils of different make in the sump.

## Water

To ensure the correct functioning of the cooling system and particularly the thermostat, it is essential that the water level be well above the bottom of the top tank—approximately 2 in. from the top of the filler. Any surplus that may be introduced will be ejected automatically through the overflow pipe provided, when the water expands as the engine warms up.

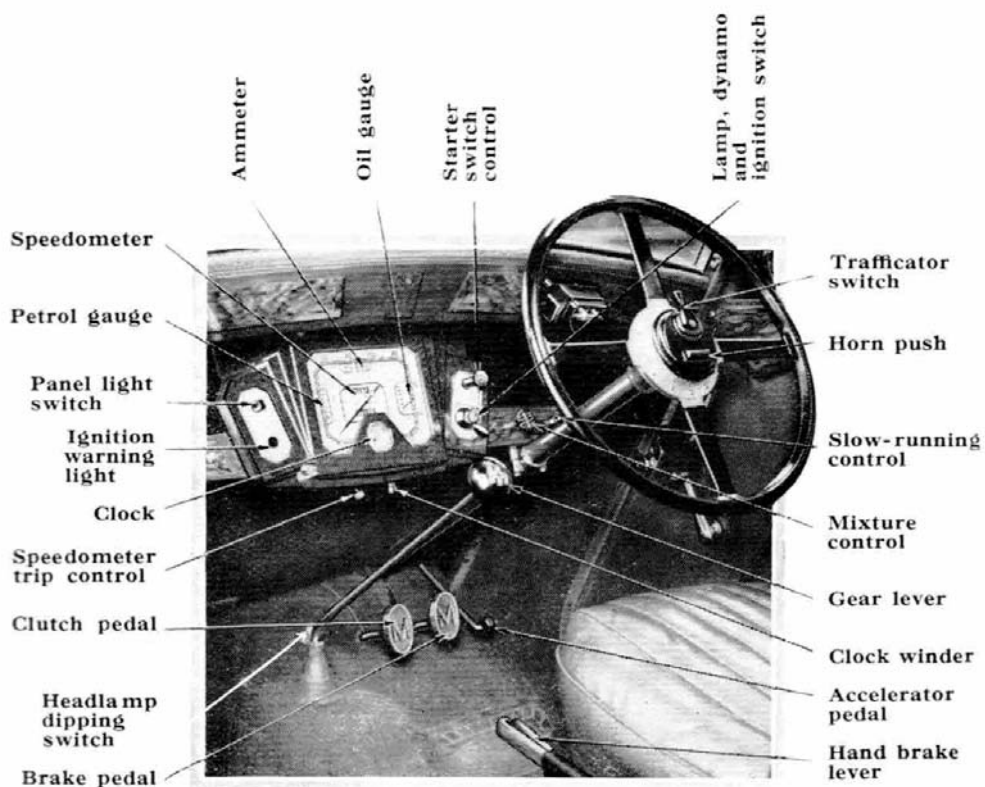

The controls of the Wolseley 10/40 and 12/48.

# The Controls

Before taking the car on the road you should make yourself thoroughly familiar with the position and function of the various controls.

## THE DRIVING POSITION

The position of the driver's seat and the pedals can easily be modified to suit different drivers and the first essential is to adjust these to give you the most comfortable driving position.

The seat is mounted on slides and is instantly adjustable by depressing the catch just in front of the seat. The pedals can be adjusted for position by withdrawing the clamp bolt passing through the upper end of the pedal arm, moving the pedal into the desired position and reinserting the clamp bolt into engagement with the nearest notch in the pedal stem. Take care, however, to allow the pedals sufficient travel.

## HAND CONTROLS

### Car Change Lever and Hand Brake

In the centre of the car is a lever ending in a large black knob; this is the gear lever. To the rear of this, between the front seats, is the hand brake lever and it is pulled upwards to apply the hand brake. To release, apply a further pull to take the load and at the same time depress the ratchet catch lever.

### The Mixture Control

Projecting through the fascia board just above the steering column are two molded knobs ; the left-hand one is the mixture control and serves to regulate the proportion of the petrol and air mixture supplied to the engine. When starting up from cold this knob should be pulled right out as far as it will go and slightly turned to engage the catch, which will hold it open. *It must on no account be maintained in this position for any length of time or neat petrol may be drawn into the cylinders causing considerable damage.* As soon as the engine starts running this knob should be pushed in as far as it will go without causing the engine to hesitate and splutter.

You will soon become familiar with the correct actuation of this control after a little practice, and there are eight alternative positions where the control can be locked to enable you to obtain the best results.

### The Throttle or Slow-Running Control

In order to prevent the engine from stopping each time the foot is taken off the accelerator when the engine is cold and during the warm-up period a hand control is provided for the throttle, limiting its closed position .

This is the right-hand knob in the fascia board just above the steering column. When it is turned anti-clockwise it opens the throttle and increases the engine speed ; when it is turned clockwise it reduces the engine speed. It should be set so that the engine idles comfortably and not too fast, and it should be gradually released as the engine warms up.

*This control should normally be in the fully closed position when the engine is at its normal working temperature, and it should not be used to regulate the slow running under these conditions. The slow running when the engine is hot should be controlled entirely by the carburetter setting (see page 34) and the hand control should then be clear of the foot-controlled mechanism.*

## **FOOT CONTROLS**

### **Clutch, Brake and Accelerator**

Projecting from the floorboards in front of the driver's seat are three pedals, two with large oval heads and, to the right of these, a smaller one terminating in a roller head. These, from left to right, are the clutch pedal, the brake pedal and the accelerator pedal.

### **Dipping Headlamps**

To the left of these pedals in the centre of the sloping footboard will be found a plunger type switch. This operates the dipping headlamp mechanism and is of the single-acting repeating type. Depression of this switch with the foot brings the dipping mechanism into action and it will remain in action when the foot is removed from it

A further depression of the switch with the foot will release the dipping mechanism when full illumination is required again. This scheme obviates the necessity for the driver maintaining his foot on the switch during the whole dipping period and leaves it free for clutch operation if required.

## **AUTOMATIC CONTROLS**

The distributor fitted to the Wolseley 10/40 and 12/48 is of the fully automatic type and requires no attention from the driver beyond regular lubrication attention outlined on page 76.

A thermostat is fitted in the water outlet pipe from the engine, which automatically regulates the flow of cooling water through the cylinder block and ensures that the engine is always working at its most efficient temperature.

The dynamo is provided with three charge rates, two of which can be controlled by the switch provided on the instrument panel, the third being controlled automatically when the lights are switched on.

## THE SWITCHES

### **The Dynamo and Lighting Switch**

The switch controlling the lamps is situated in the lower half of the right-hand instrument panel and is a large rotary switch with operating lever. It has four positions clearly marked on the panel face. The first of these is " Summer," in which position all lamps are " off " and the dynamo is giving half its normal charge. When the switch is rotated into the "Winter" position the lamps are still " off " but the dynamo is giving an increased charge. The rest of the switch scarcely needs explanation. When the switch coincides with the word " Side " the sidelamps and tail-lamp are switched on, and when the switch is rotated still further into the " Head " position, side, tail and head-lamps are all switched on, the headlamps being under the additional control of the foot dipping switch.

The dynamo is arranged to give a suitable output automatically when either the head- or the sidelamps are switched on.

### **Ignition Switch**

The ignition switch is located in the centre of the lighting switch and serves to switch the engine on and off. It is of the locking type is operated by a removable key so that when turned into the 'off' position and the key withdrawn the ignition is permanently switched off to prevent the engine from being started by unauthorized persons. Care should therefore be taken not to lose this key. New keys can be obtained from Wilmot-Breeden Ltd., Eastern Works, Camden Street, Birmingham, on quoting the number stamped on the face of the lock.

In addition to switching on the ignition this key switch also switches on the petrol gauge and the petrol pump, which will be heard pumping one or two strokes. The petrol gauge will now indicate the contents of the petrol tank.

*The ignition switch must always be turned to the " off " position immediately the engine stops, except momentarily, in order to prevent the discharge of battery current through the ignition coil. Any such discharge will be indicated by the lighting of the red warning lamp in the lower portion of the left-hand instrument panel.*

### **The Starter Switch**

The switch is mounted on the starter motor and is actuated by the knob in the upper portion of the right-hand instrument panel. Pulling the knob out actuates the switch and it should be returned to the " off " position immediately the engine fires. The switch should always be operated smartly and decisively both when switching on and off.

### **Reverse Lamp, Foglamp and Inspection Lamp Sockets**

Mounted in a specially shaped bracket, fitted on the instrument board close to the steering column, are two switches, one of which is for the foglamp and the other for the reversing lamp. These switches have the knobs engraved to designate which lamp each switch controls. Between the switches are situated a pair of sockets where an inspection lamp can be plugged in.

The foglamp can only be switched on when the ignition is switched on.

The reversing lamp can only be switched on when the sidelamps are switched on.

The inspection lamp sockets are usable at all times and, being fed directly from the battery, are independent of all other electrical equipment.

### **Instrument Panel Lamps**

The lamps illuminating the instrument panel are controlled by rotating the switch in the upper portion of the left-hand instrument panel.

### **Trafficator Switch**

The switch operating the Trafficator arms is situated at the top of the large black disc in the centre of the steering wheel. When moved to the left it operates the near-side Trafficator arm, when moved to the right it operates the off-side Trafficator arm. The switch is of the self-cancelling type which switches off the Trafficator arms as the steering wheel is returned to the straight-ahead position after negotiating a corner.

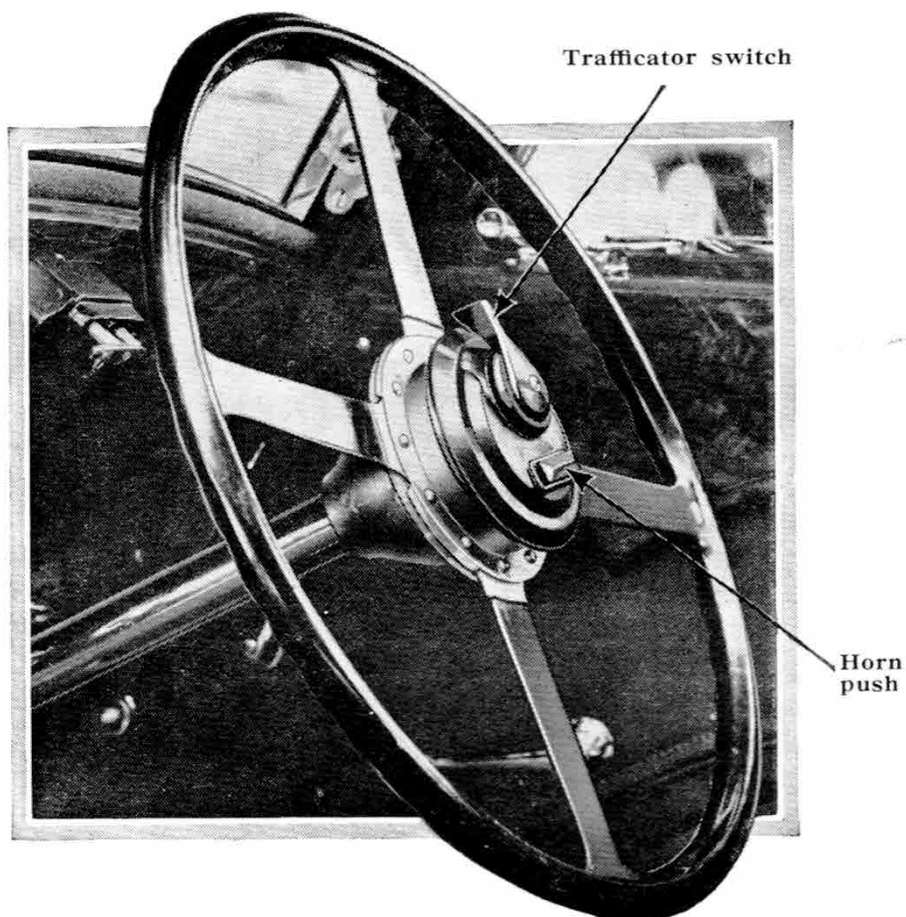

The self-cancelling Trafficator switch and the horn push are mounted in the centre of the steering wheel.



### **Horn Push**

The electric horn is actuated by the rectangular push button in the black disc in the centre of the steering wheel.

### **Petrol Tap**

The action of switching off the ignition also switches off the petrol pump which ceases to function. There is therefore no need for a separate petrol tap and none is fitted.

## **INSTRUMENTS**

The instruments provided in the Wolseley 10/40 and 12/48 provide the driver with all the information he requires to know.

### **Speedometer**

The centre panel of the instrument board comprises a large speedometer with square pattern dial, in the centre of which is a mileage recorder, indicating the total mileage which the car has covered, and also a similar recorder, which can be reset at will to zero, for indicating trip mileages. The latter is reset to zero by means of a knob projecting downwards from the back of the panel. Pushing the knob upwards and rotating it a few times brings the figures back to zero.

### **Ammeter**

At the top of the speedometer dial is a smaller scale and pointer. This is the ammeter and its pointer swings to the right or left, indicating either that current is being taken from the battery or delivered to it. When no lights are on and the switch is turned to the mark " Winter " the ammeter needle should swing over to the right-hand side until it reads between 8 and 10 amperes when the car is running at 20 to 25 miles an hour. If the ammeter does not register when the switch is in that position and the car is traveling at this speed with no lights on it means that either the fuse has blown or attention must be given to the electrical system (see section on electrical equipment, pages 86-97)

### **Oil Gauge**

The right-hand scale in the speedometer dial is the oil gauge. This indicates the pressure of lubricating oil that is being pumped through the engine. It will naturally show a higher figure when the oil is cold when starting, and therefore thick, and it will gradually fall as normal running temperature is reached, when it should register from 40-80 lb. at normal running speeds, depending on the condition of the bearings. Provided the pressure does not drop far below 40 lb. when the car is traveling at 25 m.p.h. it can be taken that the oil circulation is satisfactory.

### **Petrol Gauge**

This is the left-hand scale in the speedometer dial and it gives indication of the petrol tank contents. Remember that it only functions when the ignition is switched on.

## STARTING UP

Before starting up the engine from cold make sure that the gear lever is in the central or neutral position—that is to say, it is free to move sideways. Pull out the mixture control knob on the left of the steering column as far as it will go, turning it to engage the catch and pull out the slow-running control knob on the right of the column. Turn the ignition key switch on the instrument panel into the " on" position and pull the small plunger just above the switch out smartly. The engine will be heard revolving and after a second or two should fire, when the starter switch plunger must be released immediately. *With a new car or in cold weather the engine should be turned by the starting handle with the ignition switch " off" before the electric starter is used.* It is bad practice to keep the starter switch " on " if the starter is not turning the engine round, as may happen if the battery becomes run down, or with a new stiff engine, or in very cold weather.

**NOTE.—It is extremely bad practice to allow the engine to warm up from cold by letting it idle slowly.**

**The correct procedure is to let the engine turn over fairly fast (approximately 1000 r.p.m., corresponding to a speed of 20 m.p.h. in top gear), so that it attains its correct working temperature as QUICKLY AS POSSIBLE.**

**Allowing the engine to work slowly in a cold state leads to excessive cylinder wear, as the low speed of revolution does not throw the oil on to the cylinder walls in sufficient quantities to ensure proper lubrication of the pistons. Far less damage is done by driving the car on the road straight from cold than by letting it idle slowly in the garage.**

If piston wear is to be kept at a minimum it is essential that the cylinder wall should be maintained in a copiously lubricated condition, and this can only be assured by reasonably high revolutions, in conjunction with normal oil pressure and clear oil passages.

Should the starter jam it can be released by rotating the spindle by means of the square provided on the end. The spindle end is protected by a tubular sleeve which must first be removed.

## THE GEAR POSITIONS

Neutral position is in the centre, where the lever is free to move from side to side.

First gear is forward to the left.

Second gear is rearward to the left.

Third gear is forward to the right.

Fourth or top gear is rearward to the right.

Reverse gear is to the extreme right, against the restraining action of the spring-loaded safety fence, and rearwards.

The engagement of top and third gears is rendered particularly easy by the provision of the synchromesh device.

## Getting in Gear

The procedure after getting into the car and starting the engine is to press the clutch pedal down as far as it will go and keep it there for a few seconds, with the engine running slowly. This releases the clutch, and the gear lever can then be swung to the left and forward, which will engage the first speed, or low gear.

The gears should engage easily. Do not use force. Should the gears not engage readily, repeat the instructions in the previous paragraph.

The hand brake should now be released and the clutch pedal gradually let up ; simultaneously the engine should be accelerated by gentle pressure of the foot on the accelerator pedal and the car will then move off smoothly.

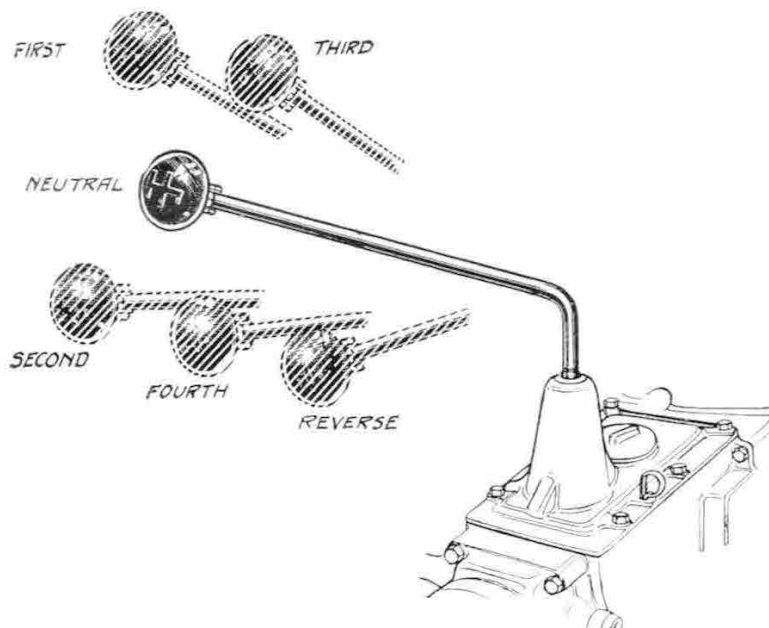

The gear positions.

## Changing Gear

*It should always be remembered that the engine should have the opportunity of increasing its speed when changing to a lower gear, but must lose speed when changing to a higher.*

When the car has gained some headway change into second speed. To do this, again depress the clutch pedal, bring the gear lever into the neutral position, make a slight pause, then swing it straight back, when the second-speed gear will be engaged. The clutch pedal should now again be gradually released.

To change into third gear the same procedure is adopted, but the gear lever is moved to the right and forward after being brought back to the neutral position. Third speed is provided with a synchromesh clutch which levels up the speeds of the components to be engaged, providing the gear lever is moved reasonably slowly in order to give the synchromesh device time to function. Actually a slight resistance

will be felt between the " neutral " position and the " fully engaged " position, indicating the point where the synchromesh clutch members engage, and a slight pause should be made with the gear lever held in this position to give the synchromesh clutch time to do its work and enable the gear to engage easily.

To change into fourth speed, or top, again repeat the foregoing instructions, but bring the gear lever straight back. This gear is also fitted with the synchromesh device and the same pause should be made between the neutral and fully engaged positions.

The reverse position is towards the rear on the extreme right side. Care should be exercised when changing from third speed into top to avoid pushing the gear lever into reverse, as this will result in setting up a tremendous strain on the gear wheels, and might cause a serious breakdown. This is guarded against by a safety spring, the tension of which must be overcome before the gear lever can be moved into the reverse position. The same damage would result if the forward gear were engaged before the car had lost its backward motion.

*Never engage a gear which will reverse the direction of travel of the car until it has come to an absolute standstill.*

When changing gear up from first to second, the clutch pedal should be pressed down and the foot momentarily taken off the accelerator whilst the change is being made. A pause in the neutral position is advisable.

When changing down from third to second, or second to first, the clutch pedal should be depressed, and after waiting for half a second, *with the throttle remaining open for the engine to gain speed*, the change can be made noiselessly. The expert driver will have recourse to double declutching in this instance, but this requires a little tuition and practice. We advise all drivers, however, to take the necessary steps to become thoroughly familiar with this method of changing gear at the earliest possible opportunity.

## **Stopping the Car**

The Wolseley 10/40 and 12/48 cars are fitted with Lockheed hydraulic four wheel brakes that ensure maximum braking efficiency under the most severe conditions.

To slow down, take foot off accelerator and if necessary apply foot brake gently. To stop, slow down as indicated, apply foot brake gently and declutch as soon as the car speed falls below 6 m.p.h. Apply hand brake and place the gear lever into neutral position, i.e. in the centre. You may now release the clutch and switch off the engine. Always try to pull up as though the car had no brakes, when opportunity allows. This saves tyre wear and helps to prolong the life of the car.

The brake pedal operates hydraulic brakes on back and front wheels, the hand lever operating on brake-shoes in the rear wheels. The foot brake is intended for general use and the hand brake for emergency and parking.

Never apply the brakes so hard that the wheels become locked. This only produces excessive wear and actually reduces the braking efficiency.

### **Descending Steep Hills**

On approaching a hill which is known to be steep, slow down the car and engage third or second gear before the descent is begun. The foot can then be removed from the accelerator and the clutch left in engagement. This will enable the engine to function as a brake, leaving the hand and foot brakes for additional braking and emergency. When using the engine as a brake it is unadvisable to switch off the ignition, as this is liable to cause the plugs to become oiled up and there is danger of an explosion in the silencer.

Do not coast down hills by depressing the clutch pedal. This is definitely bad practice and only produces unnecessary wear on the clutch pedal mechanism.

#### **TOP DEAD CENTRE**

To facilitate the location of top dead centre for ignition timing or other purposes, the crankshaft belt pulley flange of the 12/48 engine has a small hole drilled in it at the top dead centre position of the crankshaft for Nos. 1 & 4 cylinders, and an arrow is provided on the timing chain cover to facilitate its correct location.

## The Power Unit of the Wolseley 12/48

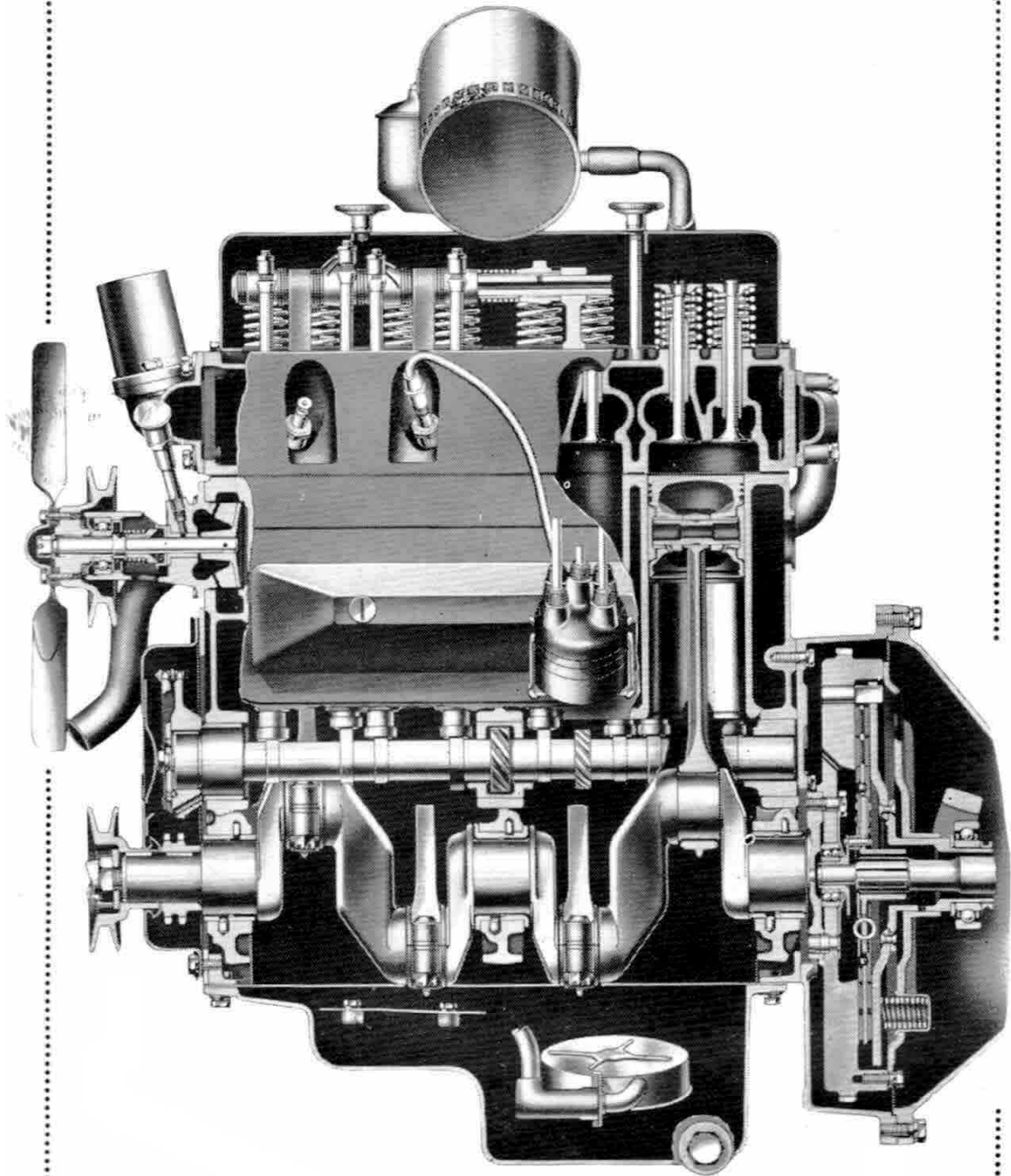

# General Care of the Car

## New Engines

WHEN the car is given its first run it may be noticed that power is lacking for about 150 to 200 miles. The reason for this is that the engine is stiff on account of the parts being a very accurate fit. When the car is further used, however, this lack of power will gradually disappear as the engine is run in. There will be a progressive improvement in the engine and the car generally for the first 1000 miles if proper care is exercised. It is a great mistake to drive a new car fast. It should be driven at a very moderate pace for the first 1000 miles, or the life of the car will be greatly shortened and its efficiency destroyed.

The use of upper cylinder lubricant is an advantage during the running-in period. One eggcupful of engine oil, or one of the special oils procurable, added to each gallon of petrol is sufficient.

**For the first 1000 miles 35 m.p.h. must not be exceeded in top gear, 26 m.p.h. in third, 15 m.p.h. in second gear or 10 m.p.h. in bottom gear. In addition, the engine should never be raced when cold.**

New engines should be given proper attention during the first 1000 miles if they are to be ensured a long life. At the conclusion of the first 1000 miles the tappet clearances should be checked and the tappets adjusted if necessary (see page 21). The cylinder head stud nuts also should be tightened after the first 500 miles and the engine should be drained at 500 miles and refilled with fresh oil.

## Care of the Coachwork

The cellulose finish of the Wolseley 10/40 and 12/48 cars may be dusted with a dry cloth without in any way harming the surface, but it is always advisable to remove mud, either in the wet or dry state, by carefully washing off with an abundant quantity of water. Whenever possible, the mud should be removed while still wet and not allowed to dry. Tar which may find its way on to the surface can readily be removed with a cloth damped with benzole. It is of considerable advantage to give the cellulose finish a thorough polish once a week with a special cellulose polish free from abrasive procurable from your Dealer. We recommend the use of Belco No. 7 Polish or Karpol Cellulose Cleaner.

## Wings

The wings are finished in synthetic lacquer and should not be dusted with a dry duster, but always washed down with plenty of water. No attempt should be made to remove tar spots by the use of benzole or a similar medium, but they may be removed by the diligent and careful application of Dockers' "Cellusol" Liquid Polish No. 1684 or Karpol "Paint and Varnish" Cleaner. These preparations may also be used for polishing the wings.

After the wings have been well washed down with hose and sponge, all beads of water remaining should carefully be cleaned off with a chamois leather.

### **Care of the Upholstery**

The cushions of a car should be cleaned periodically. Accumulations of dirt, if left too long, eventually work right through into the pores of the leather, giving it a soiled appearance not easily remedied.

Cars upholstered with leather can be kept clean by occasionally wiping the cushions over with a damp (not wet) cloth. If necessary a little neutral soap such as " curd " or " toilet soap " may be used, but caustic soaps, petrol or spirit of any kind must on no account be used, as these have a very deleterious action on the leather.

### **Radiator and Cooling System**

It is of some importance that the radiator be filled only with clean rain water. The use of hard water for this purpose results in the deposit of the impurities which it contains on the surface of the water passages of the cooling system, reducing its efficiency. It is therefore advisable to drain out the cooling system approximately every three months (except when anti-freezing mixture is used) and flush it out with water by inserting a hose pipe in the filler opening, leaving the drain tap open. The capacity of the cooling system of the Wolseley 10/40 is 18 pints, and that of the 12/48 18 pints.

### **Frosty Weather**

If the car is not stored in a warmed building, steps must be taken to prevent the cooling water from freezing during frosty weather. Water upon freezing expands, with the result that there is a very considerable risk of bursting either the radiator or the cylinder block by the pressure generated. As a precautionary measure, when frost is anticipated, the water should be drawn from the radiator before the car is stored for the night, not forgetting to remove the plug in the off-side of the cylinder block so as to release the water trapped in the cylinder jackets by the pump. When refilling in the morning it is of advantage to use hot water, firstly because it facilitates starting and secondly, it is more free from those impurities which form deposits in the cooling system.

Anti-freezing solutions may be used in the radiator to overcome severe climatic conditions.

We recommend owners to use Smith's " Bluecol " non-corrosive anti-freeze in order to protect the cooling system during frosty weather and reduce corrosion to a minimum.

The recommended " Bluecol " quantity for Wolseley 10/40 and 12/48 models is Nos. 0 and 1y sizes.

With this anti-freeze in the cooling water it is unnecessary to drain the system, even in the coldest weather, and one filling lasts the whole winter.



" Bluecol " does not evaporate, providing the cooling system is not allowed to boil—therefore it is only necessary to top-up in the usual manner.

Before introducing either of the above anti-freeze mixtures to the radiator it is advisable to clean out the cooling system thoroughly by draining out the water and swilling out the water passages with a Lose inserted in the radiator water filler cap opening, keeping the drain tap open the while.

### **The Springs**

The spring clips which secure the front and rear springs to the axles should be examined periodically to see that they are bolted up tight. It is essential, particularly when the car is new, to test the nuts on these clips to ensure that no slackness has taken place. The majority of spring failures are traceable to the fact that slackness has occurred at these points and has not been attended to.

### **Tyre Pressures**

The pressure at which large-section tyres are run is most important, as the type of tyre is more sensitive to its degree of inflation than are older types. The table given on page 64 should be adhered to rigidly.

Once a tyre is punctured do not leave it on the spare wheel but have it repaired as soon as possible, or the advantage of the fifth wheel is lost. The spare wheel tyre should always be in repair and fully inflated.

### **Chromium Finish**

The introduction of chromium finish has the effect of greatly reducing the labour previously entailed in cleaning the bright portions of the car. The chromium finished parts of the Wolseley 10/40 and 12/48 should on no account be cleaned by the use of metal polishes (all of which contain a certain amount of abrasive matter), but by the expedient of washing the parts with plenty of water and, when the dirt has been removed, polishing the surface with a clean dry cloth, or with chamois leather, until bright. In short, chromium finish should be treated in precisely the same way as coachwork and no special polish of any description is necessary.

All that is necessary to maintain the original brilliance of the chromium finished bright parts is that they should be wiped over once a week with a damp chamois leather. It is recommended that this is regularly carried out.

If the chromium finish has been neglected it may be restored to its original brilliance with soap and water applied with a soft rag.

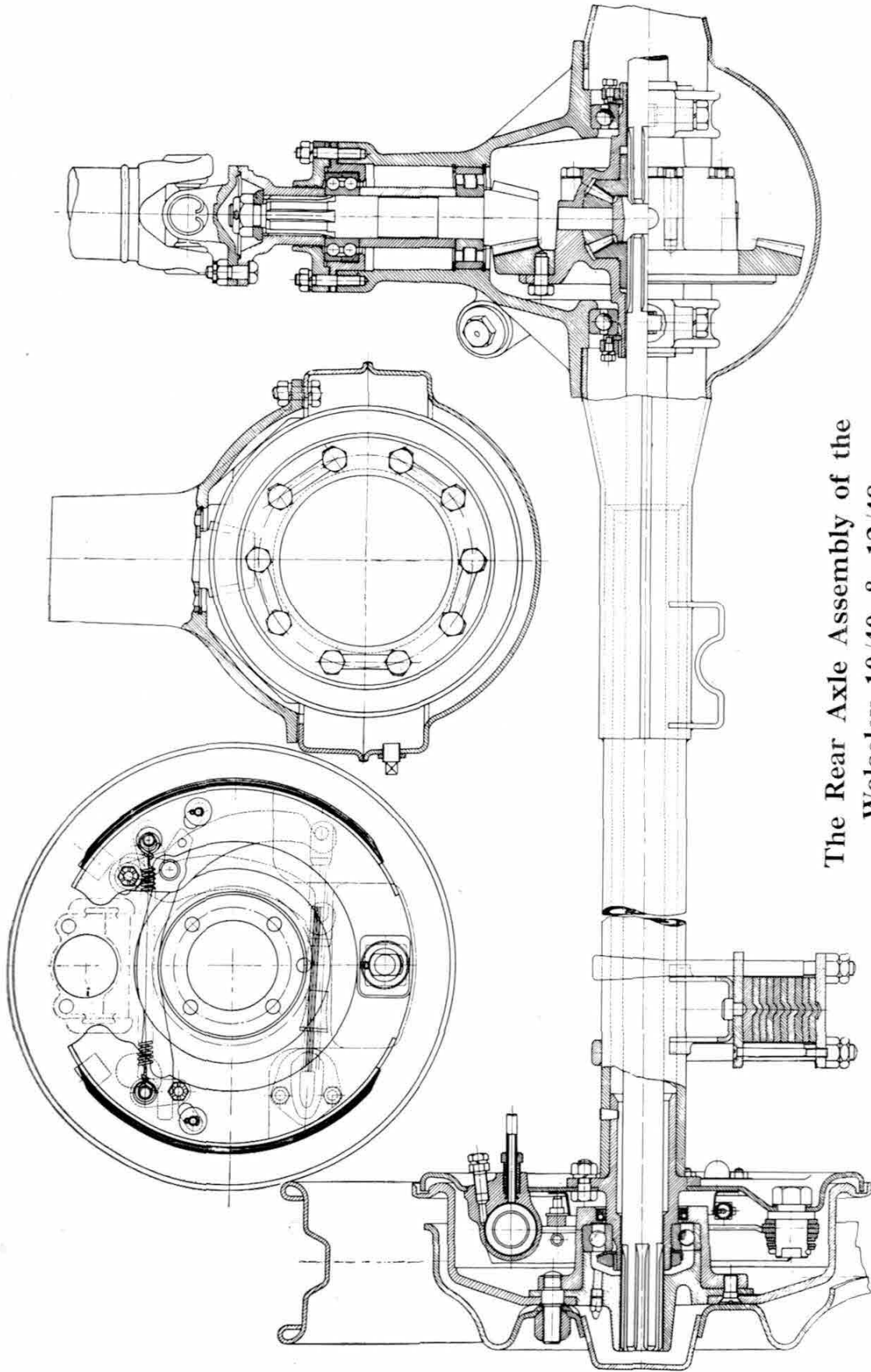

The Rear Axle Assembly of the  
Wolseley 10/40 & 12/48.

## Adjustments

### Windscreen

The single-panel windscreen fitted to Wolseley 10/40 and 12/48 cars is provided on either side with guides which can be locked in any desired position by wing nuts and thumb levers with cam action.

The thumb lever is so shaped that when the lever is pushed downwards, with the screen in the fully closed position, it engages with a projecting pin and the windscreen is firmly locked in the closed position. *It is therefore impossible to open the windscreen, even though the wing*

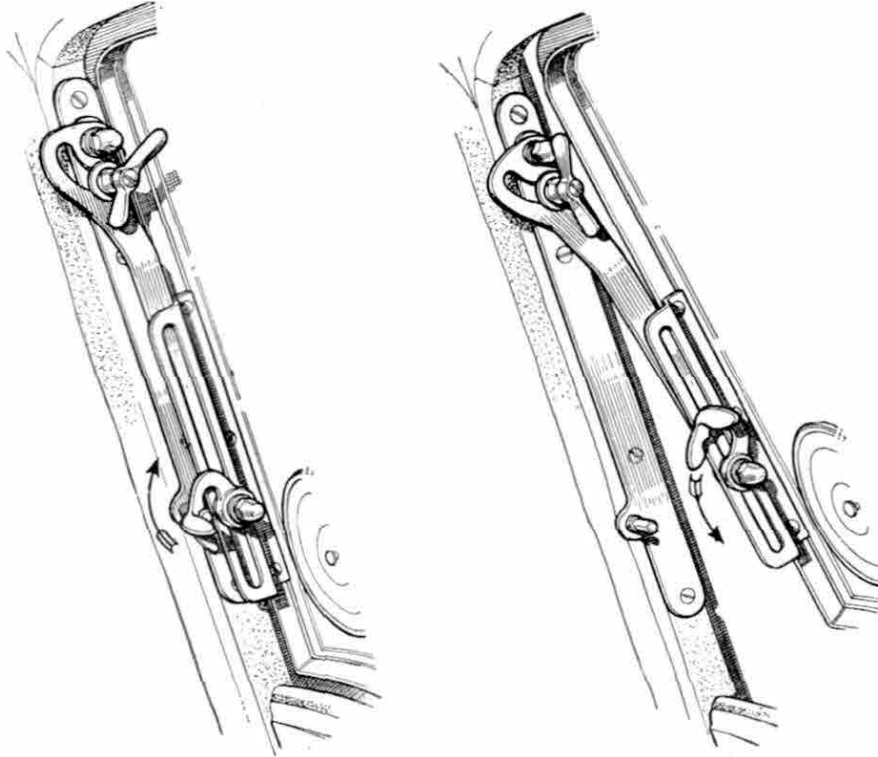

The windscreen can't be opened until the thumb levers have been pulled up in the direction of the arrow on the left-hand illustration. When the screen is open lock in position with the wing nut and by returning the thumb lever downwards as shown on the right.

*Nuts have been slackened off, until these thumb levers have been pulled Upwards by hand. To lock the windscreen in the open position, Push both thumb levers well downwards and tighten up both wing nuts.*

### Brakes

The hydraulic four-wheel brakes that are fitted on Wolseley 10/40 and 12/48 cars provide, when they are properly adjusted, the maximum possible braking power obtainable at the present time.

Their adjustment is indicated on pages 46 and 51.

### Tappets

Adjust the valve rocker screws to give a play of at least .015 in. for both inlet and exhaust valves between the end of the valve stem and the head of the rocker when the engine is warm.



**Left :-**  
The tappet adjustment screw is released for adjustment by slackening off the hexagon lock nut with a spanner while holding the tappet screw against rotation with a screwdriver. The tappet screw is relocated in a similar manner after adjustment

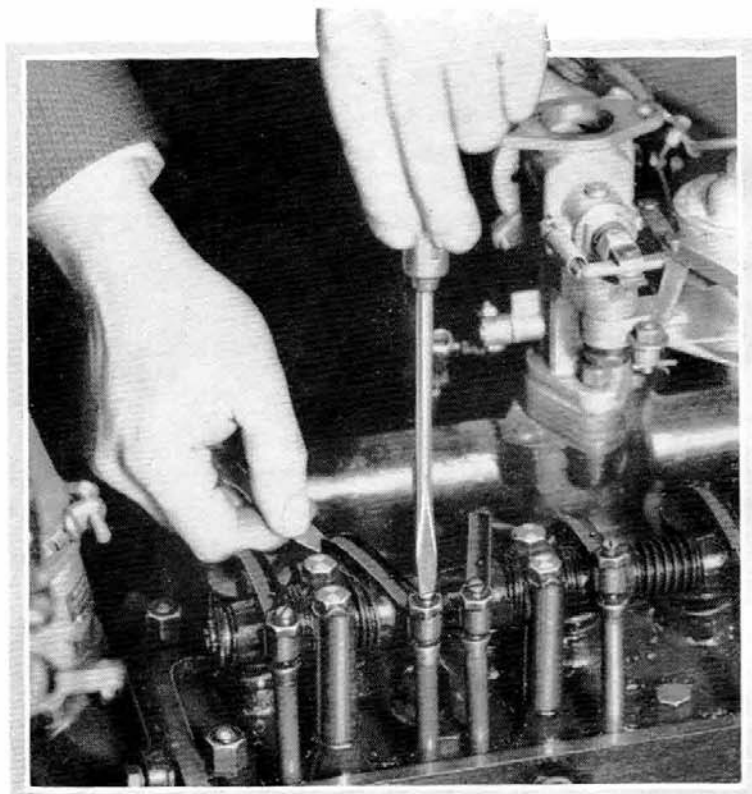

**Right :-**  
The valve clearance can then be set by carefully rotating the tappet screw while checking the clearance with the feeler gauge provided in the tool kit.

This clearance is considerably greater than normal practice, but the camshaft contours have been specially developed and no improvement in either performance or silence will be achieved by reducing this clearance. Remember, the engine has been designed to operate with this clearance and any departure from it is likely to be a source of trouble.

*It is of importance to note while the clearance is being set that the tappet of the valve being operated on is bearing on that portion of the cam which is concentric with the camshaft.*

The camshaft, however, is out of sight, but once it is realized that the pistons of numbers one and four cylinders, and numbers two and three cylinders move in unison and that while the valve of one is fully open the corresponding valve of the other is fully closed, no difficulty will be experienced in ensuring the correct position, since it is only necessary to rotate the engine by the starting handle until the corresponding valve belonging to the other cylinder paired with it is fully opened.

To assist owners and to ensure that the engine is rotated the fewest number of times, the correct sequence of tappet setting is tabulated below, No. 1 valve being at the front of the engine

### **Tappet Setting Table**

Set No. 1 tappet with No.	8 valve fully open
3	6
5	4
2	7
8	1
6	3
4	5
7	2

When the valves are ground-in the tappets must be reset, and it is advisable *when the car has run 50 to 100 miles after resetting to again check the clearance, as valves have a tendency to "bed down" a little after having been disturbed. The tappets should always be reset after tightening of the cylinder head stud nuts has taken place.*

### **Camshaft**

Great care has been taken to ensure that the camshaft has ample bearing surfaces and is adequately lubricated ; as a result this item should give no trouble whatever.

### **The Crankshaft**

The crankshafts of the Wolseley 10/40 and 12/48 are accurately balanced both statically and dynamically by the Olsen method, thus ensuring a degree of balance above the ordinary.

Attention to the crankshaft main bearings—such as those occasioned by wear—is only necessary at very long intervals if the instructions in this *Manual* have been faithfully carried out. Rectifying wear in

the crankshaft main bearings calls for a degree of skill greater than that possessed by the average owner, and he is therefore strongly advised to place any such work in the hands of a Wolseley Dealer, who has facilities for rapid and effective rectification.

### **Connecting Rods**

It should be distinctly understood by the owner that the white-metalled bearings in the Wolseley 10/40 and 12/48 engines are of the full-ring butted type—that is to say, the two halves of the white-metalled bearing completely encircle the connecting rod, and make contact with each other at their joint without leaving a gap and without the use of packing shims.

*On no account whatever must these bearings be closed together for any reason by the process of filing the caps, as this will immediately render the whole bearing non-standard and render the connecting rod valueless for future bearing replacement. The bearings are made on a system which ensures a sufficient degree of accuracy to make it totally unnecessary for the caps or rods to be touched by a file or scraper, and, in fact, renders any hand fitting superfluous.* The bearings are of a heavy type in which the white metal is run direct on to the connecting rod, and if this white metal should run in use or become worn, the connecting rods should be replaced. Under no circumstances can Wolseley Motors Ltd. recognize any trouble consequent on adjustment of these bearings by owners. Any attention required to connecting rods should be entrusted to a competent Wolseley Dealer.

The correct working clearance between the big-end bearings and the crankshaft journal is rather larger than was accepted practice a few years back, and is such that an appreciable rocking is present in the bearing when it is in an unlubricated state. The correct clearance is automatically allowed for in the machining process, and no hand work whatever is necessary or advisable. This relatively large clearance permits a substantial protective film of oil to exist between the bearing surfaces, and the connecting rod under these circumstances should fall quite freely on its journal when the big-end bearing is bolted up quite tight.

The correct clearance when fitting big-ends is .0015 in.

### **Piston and Piston Rings**

To remove a piston it is necessary to take off the sump and remove the big-end bearing cap, when the piston can be withdrawn through the crankcase. This is an operation beyond the scope of the average owner, and you are therefore advised to entrust any work of this nature to your nearest authorized Wolseley Dealer.

### **The Fan and Water Impeller**

Wolseley 10/40 and 12/48 cars are equipped with a cooling fan and water impeller mounted on a common spindle carried at the front end of the cylinder block and driven by belt from a pulley on the end of

the crankshaft. The belt tension may be adjusted by slackening the bolt clamping the dynamo to the slotted bearer arm plate and swinging the dynamo until the desired belt tension is attained. Tightening up the clamping screw will firmly relock the dynamo in position. Too great a tension on the fan belt is to be avoided as it places unnecessary load on the bearings. Only sufficient tension to overcome slip should be used.

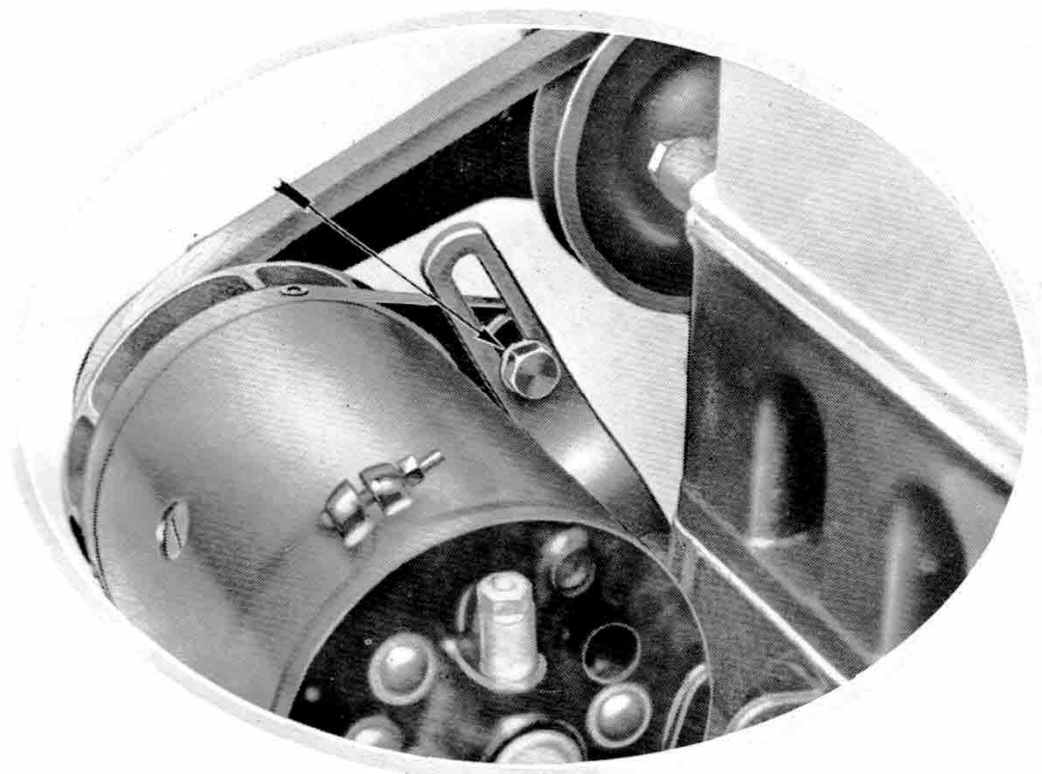

**The method of adjusting the dynamo and fan belt.**

Water is prevented from leaking from the spindle of the water impeller by a carbon ring. The ring is held in constant contact with its seating by a spring and should therefore give no trouble.

If a leakage of water is taking place at this point it may be necessary to replace the carbon ring, a matter which should be entrusted to your nearest Wolseley Dealer.

### **Dynamo**

The dynamo is attached to the left side of the cylinder block by three bolts and driven by the fan belt from the crankshaft, the tension of which is adjusted in the manner indicated in the previous paragraph.

The dynamo requires very little attention, but every 5000 miles any accumulation of carbon dust at the commutator end should be removed with the aid of a clean rag dampened with petrol.

(Detailed instructions on the care of the dynamo are to be found on page 80.)

**The Ignition** (for instructions see pages 76-79).

### **Clutch and Clutch Pedal**

The clutch provides two friction surfaces. The driving surfaces comprise (a) the rear face of the flywheel, (b) the forward face of a pressure plate. Three clutch driving pins in the flywheel cover pass through the pressure plate, which consequently revolves with the engine.

The driven surfaces comprise a double line of cork insets in a plate, the plate itself being spring mounted on to a driving hub engaging the driven shaft.

Driving pressure for the clutch is derived from a series of helical springs hearing against the pressure plate.



**The component parts of the Wolseley 10/40 and 12/48 clutch.**

The clutch must run in oil, and provision is made to ensure that the correct quantity is fed from the rear crankshaft main bearing. Persistent slipping of the clutch should not be indulged in.

Owing to its granular structure, cork consolidates considerably under pressure. The effect of this in the clutches under consideration is to allow the pressure plate to take up a position closer to the engine flywheel, and as this plate is connected with the withdrawal race on which the withdrawal fork engages, and which in turn is attached to the clutch pedal, a corresponding movement takes place in the pedal itself, causing it to take up a fresh position, projecting further



into the body of the car. There is a possibility that when this happens the clutch lever may move to such an extent that it affects the adjustment of the clutch pedal, reducing the amount of backlash present. Assuming that this has occurred, it will be necessary to reset the clutch pedal as indicated.

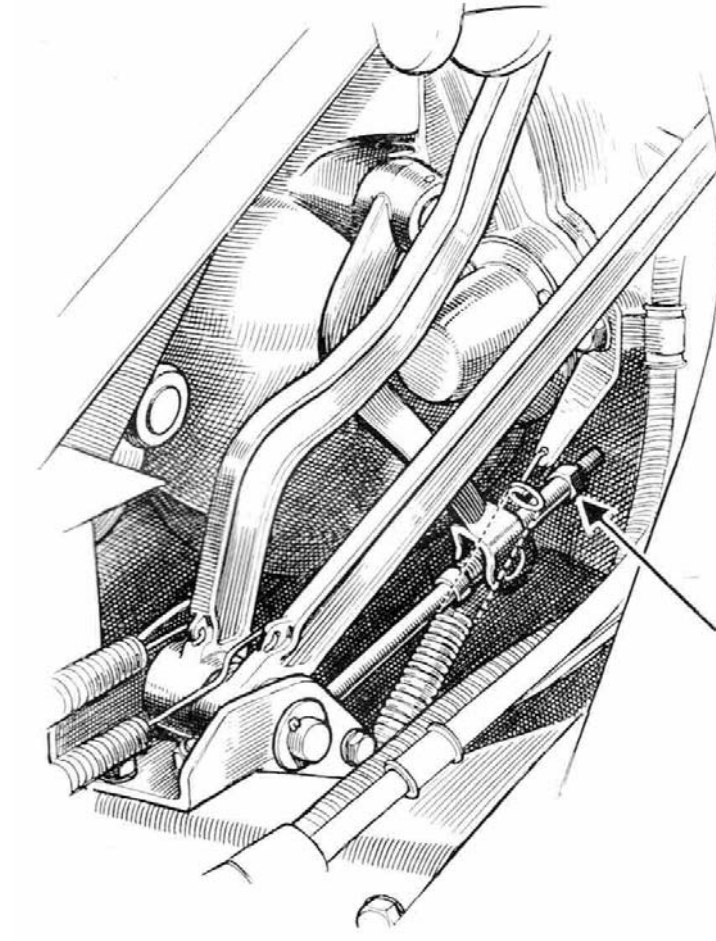

**The arrow indicates the nut by means of which the clutch pedal position is adjusted.**

This point is of particular importance during the first 2000 miles of running, as by the time this mileage has been covered the natural consolidation of the corks will be practically completed, and very little further movement is to be expected.

Adjustment of the position of the clutch pedal is easily effected by a nut on the end of the clutch pedal actuating rod.

The clearance between the clutch pedal arm and its back stop should be set to give at least  $\frac{1}{2}$  in. backlash at the pedal. The pedal return spring should be disengaged from the clutch actuating lever to facilitate feeling the extent of the backlash. The clearance between the clutch pedal arm and its stop screw should be 1 in. when the clutch withdrawal lever is just making contact with the thrust race.

## Steering Gear

The presence of stiffness in the steering gear can be ascertained by jacking the front axle so that both the front wheels are clear of the ground and rotating the steering wheel.

If stiffness exists, disconnect the rear end of the draglink from the steering drop arm. It will then be an easy matter to locate if the

Stiffness is due to the wheel mounting and steering connections, or whether it is due to stiffness in the steering column and steering gearbox assembly.

Stiffness in the wheel mounting and steering connections is usually due to lack of lubrication and should disappear immediately the steering joints have received an adequate charge of oil.

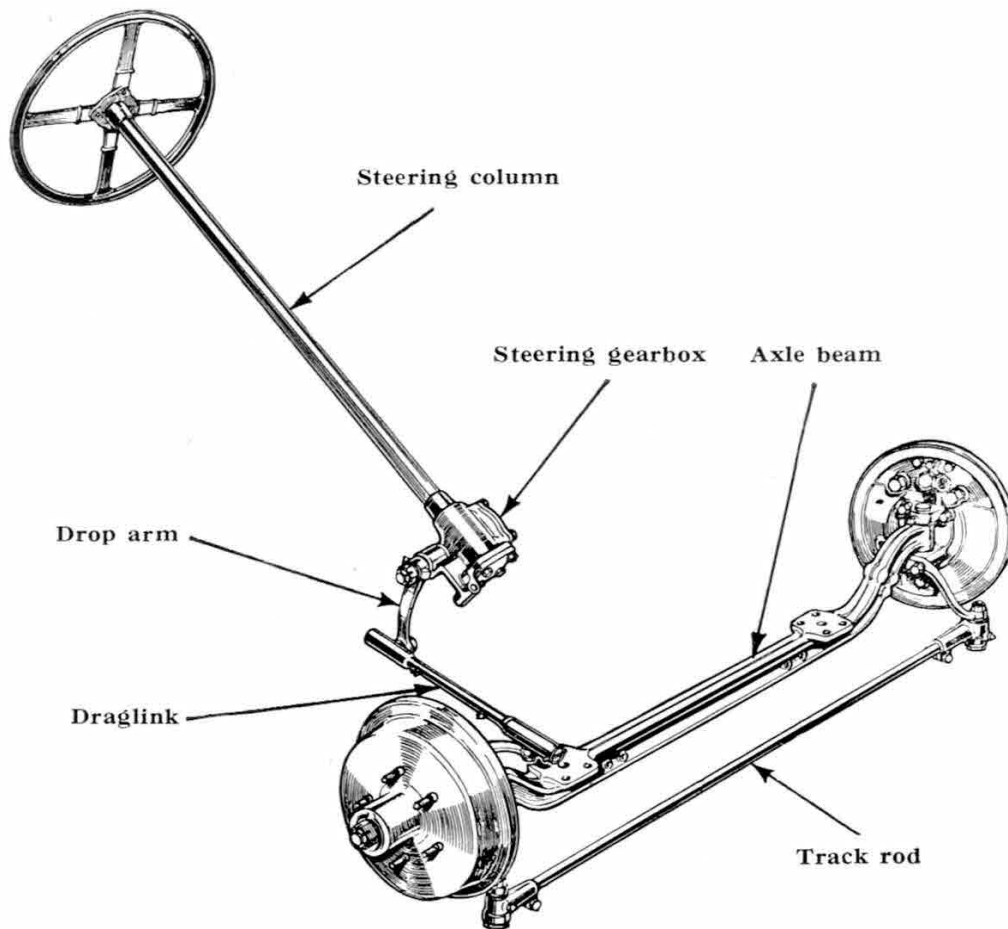

The component parts of the Wolseley 10/40 and 1248 steering gear.

Slackness in the steering column assembly is due either to excessive clearance between the cam and the hardened end of the rocker-shaft, or end play in the steering column mounting.

The presence of end play on the steering column is easily ascertained as any motion in this direction can easily be felt by lifting the steering wheel in line with the column itself. Any appreciable motion in this direction needs rectification inside the steering gearbox—a procedure which should be entrusted to a competent Wolseley Dealer.

If slackness is due to lost motion between the cam and the end of the rocker-shaft this may be rectified by removing the side cover-plate and removing one or more of the thin brass shims to be found between this cover-plate and the main casing. The cam gear is made so that there is no appreciable backlash at the bottom of the drop arm when the gear is in the paid position, although a varying degree of backlash is present in other positions of the drop arm.

The track rod is equipped with self-adjusting ball joints that require no maintenance other than the periodical lubrication attention outlined on page 61.

Every 10,000 miles attention should be given to the adjustment of the ball joints of the draglink. The locking split pin should be removed, the slotted cup nut screwed up as far as it will go, and then slackened back a quarter of a turn. It should then be relocked with a fresh split pin through the nearest slot.

If the drop arm has been withdrawn from the steering gearbox spindle ; when reconnecting, care should be taken to see that the drop arm is in its correct position, permitting full lock in both directions, the wheel stub axles coming into contact with the stops provided on the axle beam in either direction. The gearbox spindle and the drop arm are marked to facilitate their correct replacement.

### **Front Wheels**

These run on journal type ball bearings, and are protected from dirt by a special oil seal. The bearings are filled with grease before leaving the Works and should require no attention apart from the usual greasing periods.

As hub removal entails the use of a special hub withdrawing tool you are advised to entrust work of this nature to an authorized Wolseley Dealer.

If the track rod of the front axle has been dismantled, when refitting the length of the rod should be such that the distance between the forward inside edges of the wheel rims measures is in. less than does the distance between the rear inside edges, taking care to mark the rims where the first measurement is taken and to rotate the wheels through 180° so that the second measurement is taken at the same point on the wheel rims, thus eliminating any errors in the rims. To carry this out accurately a special alignment gauge is required, and you are advised to consult your nearest authorized Wolseley Dealer for attention of this nature.

### **Rear Axle**

The Wolseley 10/40 and 12/48 rear axle is of the three-quarter floating type, where the driving shafts only transmit the driving torque and do not carry any of the load. The bearings are therefore not mounted on the driving shaft itself, but on the extension of the axle casing ; and the wheel hub flange, with driving shaft attached, can be readily withdrawn.

Since withdrawal of the hub, itself entails the use of a special hub withdrawing tool you are advised to entrust this work to an authorised Wolseley Dealer.

If any adjustments to the differential bearings are required these should be entrusted to your nearest authorised Wolseley Dealer, since considerable experience is required to effect satisfactory adjustment.

### **Coachwork Adjustments**

*Loch Striker.*—On the Saloon models the plate on the body pillar, against which the bolt of the lock strikes, and the plate in which the pin on the door locates are both adjustable, so that should the lock show signs of looseness owing to wear, this can be compensated for by adjusting the plates. To test whether this is necessary, shut the door, press the outside door handle inwards and then pull outwards. If the lock-bolt can be felt hitting against the inside face of the striker-plate on the outward pull, the plates should be adjusted. The striker and pin socket each consists of a back-plate, fixed to the body pillar, and a top-plate attached to it by two cheese-headed set screws so that adjustment can be effected. The two parts have their abutting faces serrated, and, by loosening the set screws, and moving the top-plate inwards one or more serrations as required, the necessary adjustment can be effected, afterwards retightening the set screws. The lock striker-plate should first be set correctly and then the pin socket-plate moved so that it fits well up the pin.

On the Special Coupe models the adjustment to the striker-plate can be made in a similar manner, it being necessary only to loosen the single set screw holding the catch-plate of the striker to its back-plate before sliding the former inwards.

## THE AIR CLEANER, SILENCER AND FUME CONSUMER

The Wolseley 10/40 and 12/48 engines are provided with an efficient air cleaner and silencer, consisting of a large cylindrical chamber of special construction.

The air cleaner and silencer functions in the following way :—

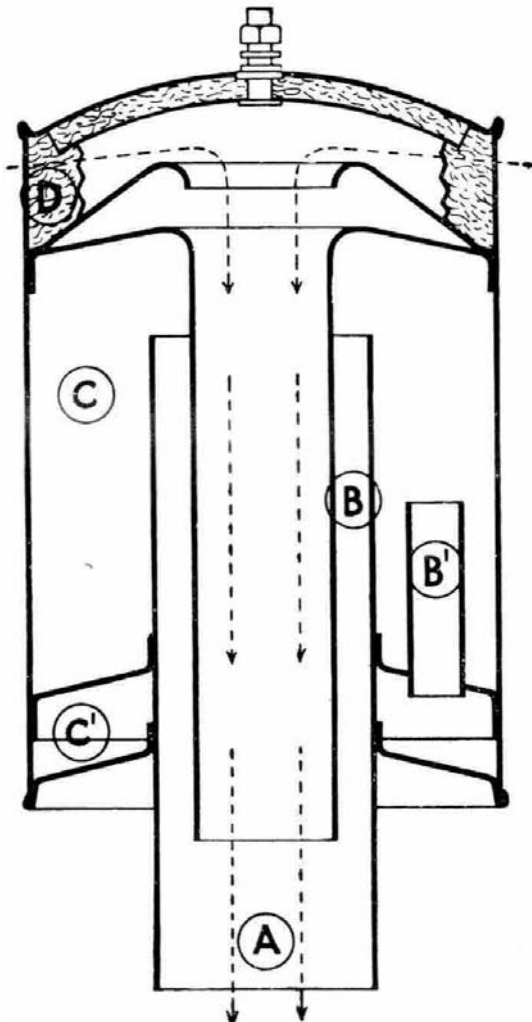

Air on its way to the carburettor passes through the central tube A. Any sound waves produced and passing out of the carburetor would also ordinarily pass through this tube into the car, but in the case of the intake silencer they pass through passages B, and B.1, into resonating chambers C and C.1, and thus set up counter waves which eliminate or considerably damp the original waves, so that no sound waves pass out of the air intake tube A. The filtering medium D is oil-wetted woven mesh to which dust from the incoming air adheres.

### Cleaning and Re-oiling

Every 5000 miles these oil-wetted air cleaners need

cleaning and re-oiling. This is best done by swilling the louvered end of the cleaner in a shallow pan of petrol, as shown in the illustration.

After drying, the filtering mesh should be re-oiled with engine oil, allowing any surplus to drain off before refitting the cleaner to engine.

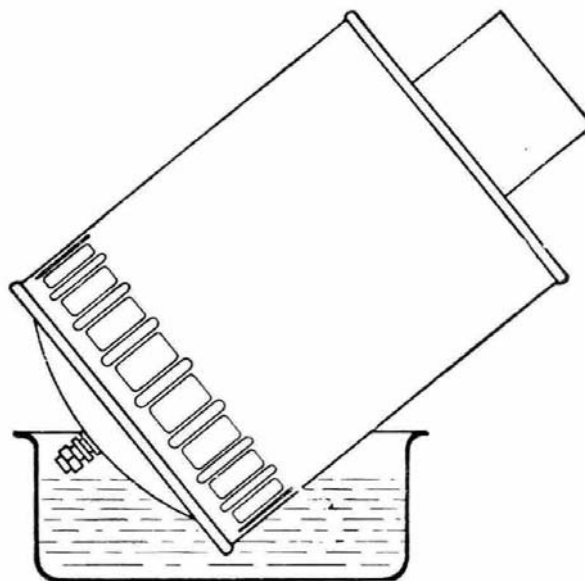

## THE JACKALL HYDRAULIC JACKS

### Jacking System

The operating cylinder for the jacks is situated beneath the floorboard which is in front of the passenger's seat, and access to it is achieved by lifting the carpet floor covering and raising the hinged cover provided in the body flooring. The jacks can be brought into action from inside the car when necessary.

To bring the jacks into action the indicator pointer should first be turned towards the required position as marked in the indicator plate, that is to say, towards " F " if the front jacks only are required, towards " R " if the rear jacks only are required, and towards " ALL " if all four jacks are required.

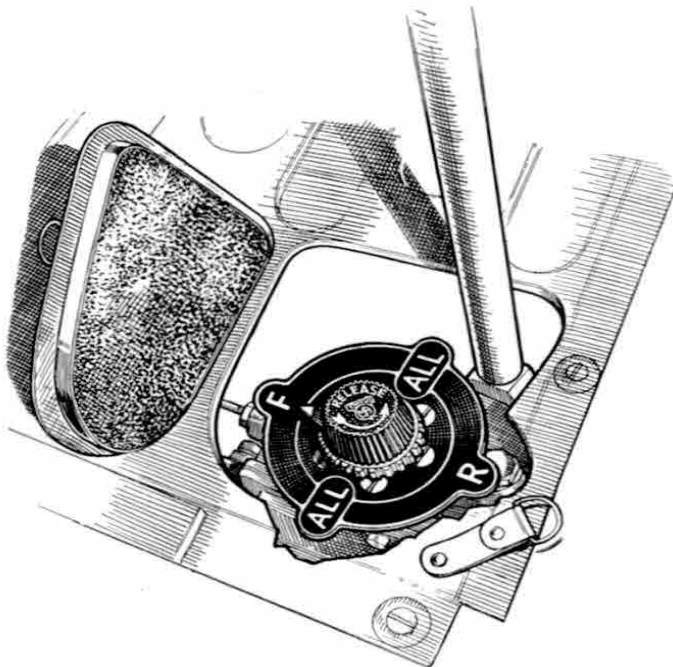

The operating cylinder for the hydraulic jacks is located below the floorboards in front of the passenger's seat.

*Before operating make quite sure that the release valve is firmly, but not forcibly, screwed down.* The operating handle should then be placed in position on the stub lever and the pump operated with a full stroke in each direction until the wheels are clear of the ground. It is to be noted that no damage can be caused by continual pumping, since a relief valve is provided to cope with any excessive pressure generated.

To release the jacks remove the handle, unscrew the release valve at least two or three turns, opening the valve slowly at first in order to lower the car gently to the ground. Once the tyres have made contact with the ground, you should then turn the indicator pointer to the " ALL " position, allowing the release valve to remain well open.

*Note* :—It is most important that the indicator pointer should always be kept at the " ALI, " position, and the release valve allowed to remain open when the jacks are not in use. This ensures the jacks returning to the inoperative position, thus preventing the possibility of accidental damage.

In the event of damage to the jacks, necessitating removal of one or more of them, the indicator pointer should be turned to the rear position while the front jacks are dealt with, and to the front position

The supply tank for The " jackall" fluid is situated on the steel dash underneath the bonnet. Take care not to confuse this with the Lockheed brake fluid tank next to it, as each needs filling with a different fluid.



while the rear jacks are attended to. This will prevent the escape of fluid, other than that contained in the pipe line between the distributor box and the jack being operated on.

If it is desired to remove the pump, the connection between the pump and the most convenient joint should be broken and the fluid pumped into a receptacle to prevent its waste.

Beyond periodical inspection of the fluid level in the supply tank the left-hand side of the dash under the bonnet and occasionally good for the shortages, the Jackall system requires no attention whatever.

The correct level for the fluid with all four jacks fully retracted is indicated by a dotted line round the supply tank about 4 in. from the top. The fluid level should not be permitted to fall appreciably below this line and never above it or insufficient room for expansion will be provided.

*Warning* :—To ensure satisfactory working of the Jackall built-in jacks it is essential that only genuine Jackall fluid should be used. This preparation is the result of extensive research, and is manufactured to a special formula which guarantees absolute protection of the rubber components and thorough lubrication of all the hearing surfaces. The use of any but genuine Jackall fluid is not only liable to render the jacking system inoperative, but automatically invalidates the maker's guarantee.

Should any faults develop, the fault)' component should be disconnected and returned to the makers, Messrs. S. Smith & Sons (Motor Accessories) Ltd., Cricklewood, London, N.W.2, for attention.

The jack cylinders can easily be removed from the axles by turning the indicator pointer to the other jacks, as previously detailed, dis-

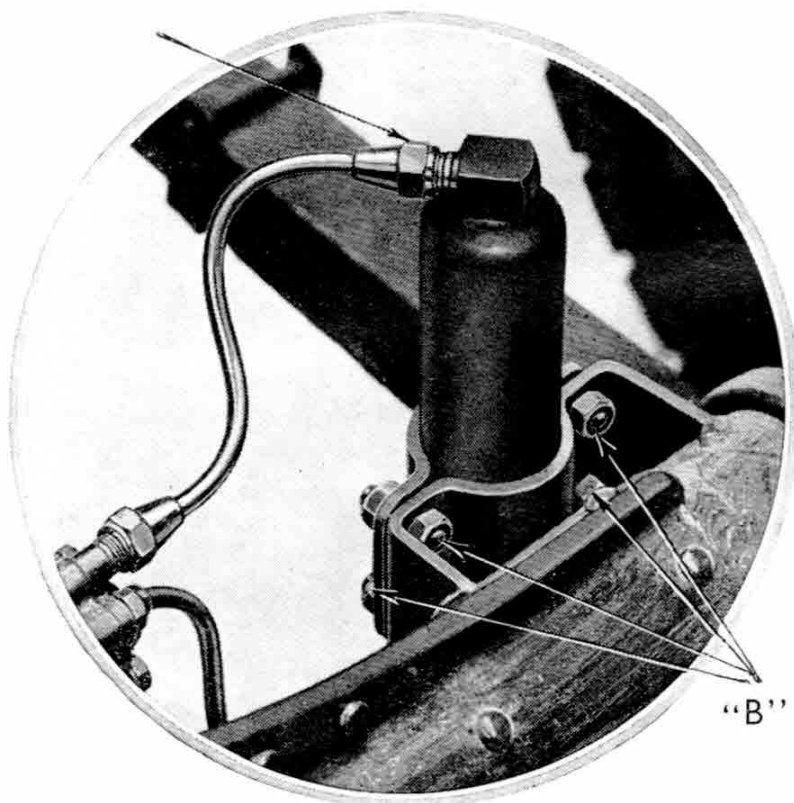

connecting the fluid delivery pipe union " A " and then the clamp-inn screws of the attachment yoke " 13," enabling the complete cylinder to be withdrawn.

When refilling the system with fluid, to make good the loss which takes place upon a disconnection, fill the supply tank in the ordinary way with the jacks fully retracted and pump the fluid into the jacks in the normal way. Release the jacks by the distributor box release, and, screwing it down again, repeat the pumping operation. Continue doing this, making good the fluid level in the supply tank each time, until no further chance takes place in the fluid level when the jacks are fully retracted. When completely empty 2 pints of Jackall fluid are required to fill the system.



# The Carburetor and its Adjustment

## The S.U. Carburetor with Controllable Jet

THE function of the carburetor is to supply to the engine a correctly proportioned mixture of petrol and air under all conditions of engine speed and load.

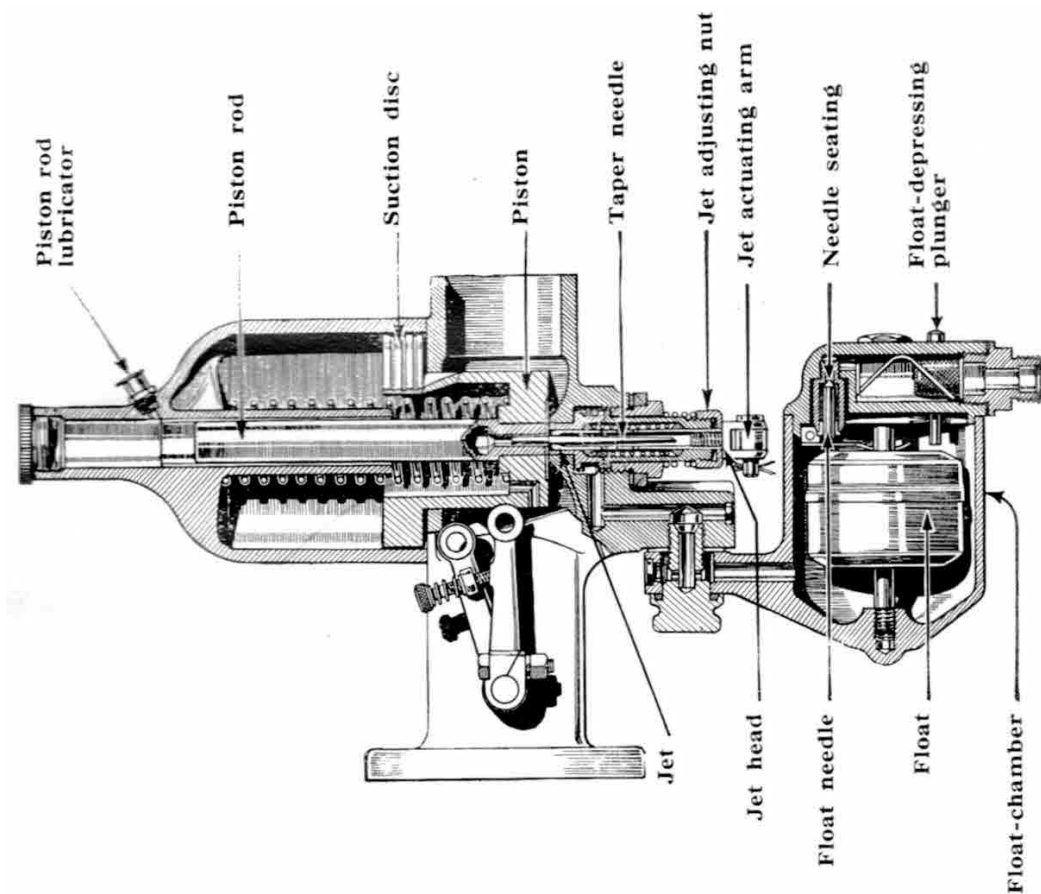

Fig. 1. The S.U. carburetor in section clearly showing its internal construction

The construction of the carburetor fitted to the Wolseley 10/40 and 12/48 can be followed in detail by reference to Fig. 1. The petrol flow to the jet is governed by a float mechanism of the "top feed" type.

Petrol from the float-chamber is led to a jet, the size of whose orifice—and consequent delivery—is regulated by means of a tapered needle attached to the end of a piston controlled by the suction from the engine. As this suction increases the needle is gradually withdrawn from the jet, enlarging its effective opening and permitting it to pass more petrol.

## ..... ADJUSTING .....

Run the engine until it attains its normal running temperature. Set the slow-running control to the right of the steering column so that the engine idles fast. Disconnect the mixture control wire from the end of the brass lever actuating the jet, and screw the jet adjusting nut well outwards. Note that the jet actuating lever is kept in contact with the jet head by its return spring and must be kept in contact during the whole of the adjusting process. The jet adjusting nut should now be screwed inwards slowly (thus gradually weakening the mixture) until the engine idles evenly, firing on all cylinders regularly, and running at its best speed. This will be the normal slow-running position when the engine is hot, and as the jet needle is of the correct size the general performance of the carburetor on the road should be entirely satisfactory. If, however, it is found that the mixture is still too rich when the adjusting nut is screwed up tight with the spring solid, it will be necessary to dismantle the suction chamber, withdraw the piston (taking great care not to damage the needle) and withdraw the needle 4 in. from its socket in piston, resetting the carburetor as previously outlined. The mixture control wire may be reconnected to the jet actuating lever when the adjustment is satisfactory, care being taken to see that the control knob has ample clearance when the jet is in contact with the adjusting nut.

Final adjustment for slow-running is then carried out by completely releasing the throttle control knob so that this control is quite clear of the accelerator control, and adjusting the carburetor throttle lever stop screw, which is spring-loaded until gentle slow running is attained.

If difficulty is encountered in obtaining complete freedom for the throttle, the adjustment provided on the carburetor end of the dash control should be made use of.

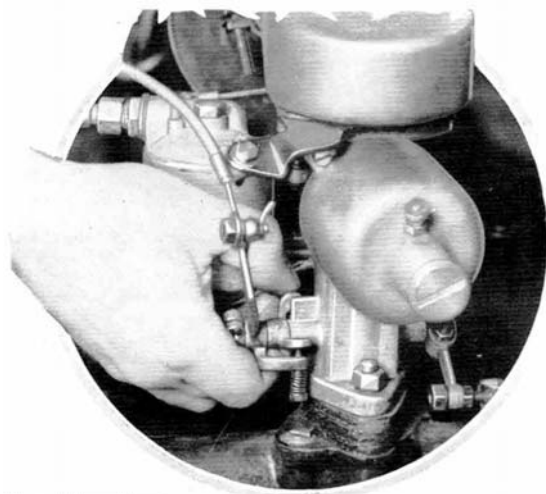

**Setting the slow-running adjusting screw on the throttle lever of the carburetor**

The jet is so mounted that it may readily be moved in or out relative to the tapered needle, in order to weaken or strengthen the mixture over the whole working range, by a lever operated from the fascia board. This control provides an enriched mixture to ensure easy starting and even running when the engine is cold. The position of the jet relative to the needle to regulate minimum mixture strength can accurately be set by means of the adjusting nut which forms an abutment for the enlarged head of the jet.

The carburettor is extremely simple, and its adjustment is equally simple if it is remembered that the jet is of a fixed standard size and cannot be altered. The correct normal position for the jet needle is with its shoulder flush with the end of the piston. The only possible adjustment is the slow-running and jet stop adjustment and, in exceptional cases, the position of the jet needle in the piston.

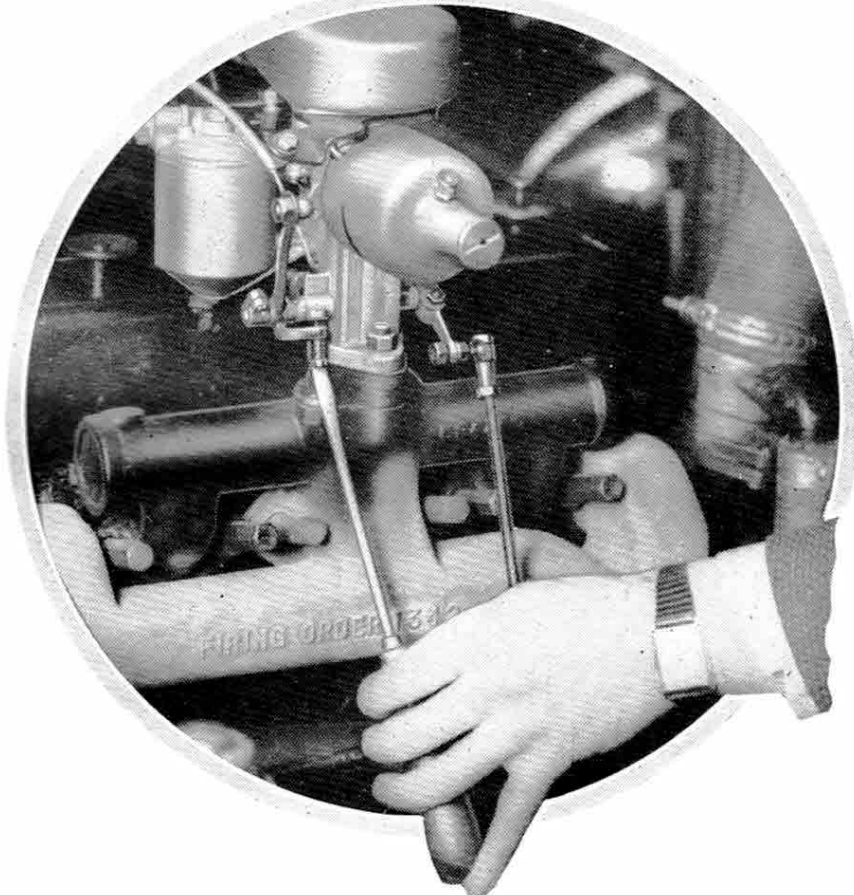

Adjusting the clearance of the dash slow-running control which should be quite clear of the throttle control.

### Sources of Trouble

There are only three troubles which may affect the functioning of the S.U. carburetor.

1. The piston may be sticking and not functioning properly.
2. There may be dirt or water in the carburetor.
3. The float mechanism may have become deranged, and the carburetor is in consequence flooding.

## Piston Sticking

The suction piston consists of the piston proper forming the choke the suction disc, into which is inserted the hardened and ground piston rod working in a bearing in the suction chamber ; a piston return spring and a tapered needle regulating the jet opening. If the piston is sticking this can easily be ascertained by inserting a finger in the air intake and moving the piston. Access to the piston is achieved by loosening the air silencer assembly from the carburettor and fume extracting pipe. The piston should move quite freely.

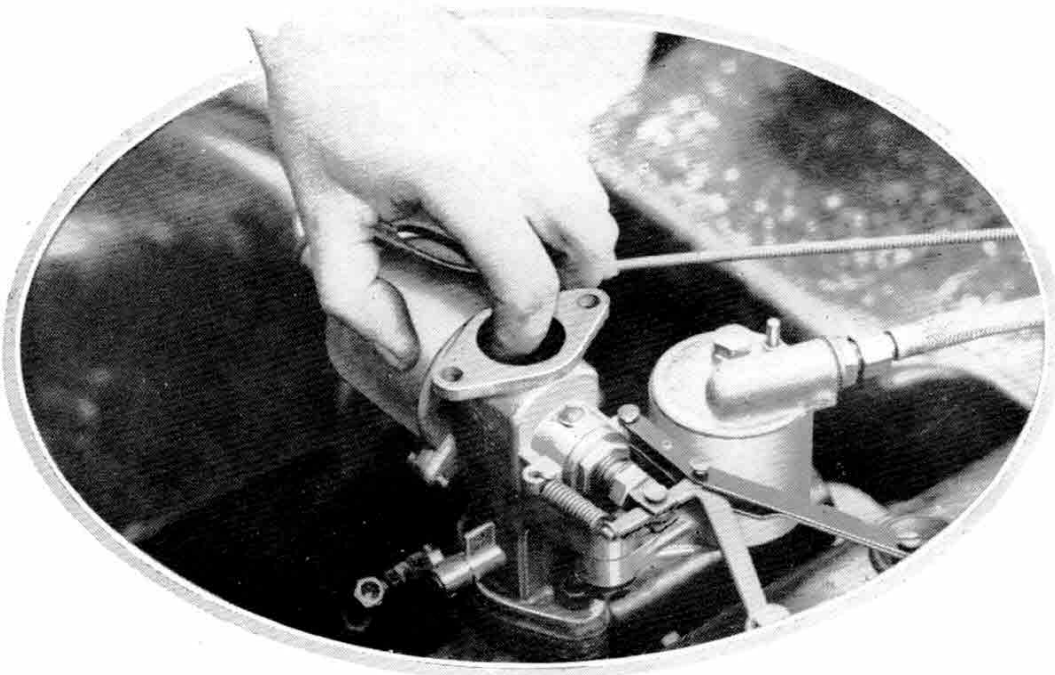

Testing the carburettor piston for freeness.

The piston rod sliding within its bearing is the only part which is in actual contact with any other part, the suction piston and its needle possessing a clearance space around them. If, therefore, the piston does not move readily it is probable that the piston rod has become dry- and sticky.

To free this, insert a few drops of good quality thin oil—such as sewing machine oil —into the lubricator on the piston rod guide. In particularly obstinate cases a little paraffin may be introduced and the piston worked backwards and forwards until it is free by inserting a finger in the air inlet. *Under no circumstances should a heavy-bodied lubricant such as engine oil be used, and no oil must be introduced on any other part of the suction chamber.*

It may be found advisable to clean out the dashpot and piston at intervals of 5000 miles if trouble is experienced in obtaining satisfactory slow-running. Great care must be exercised when doing this to see that the delicate tapered jet needle is not damaged or bent

## Water or Dirt

If this is suspected remove the air silencer assembly, then with a small article—such as a pencil—move the piston away from the jet so that the jet can be seen. Flood the carburettor by switching on the ignition and depressing the float-chamber needle and observe

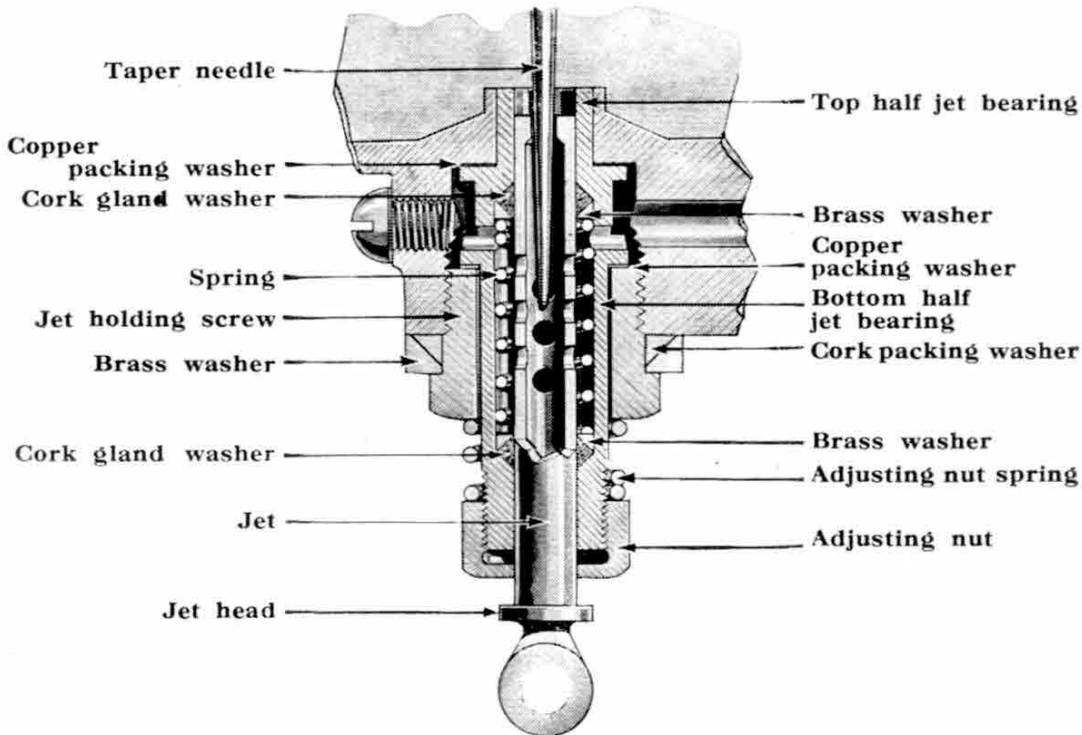

Fig. 2.

An enlarged section of the jet assembly. It will be noticed that the junction between the jet and the casing is rendered perfectly petrol-tight by means of two cork washers which are forced against the sides of the jet by a coil spring and conical washers. If the jet is dismantled great care must be taken not to lose these washers.

if the petrol issues freely from the jet. If it does not do so there is foreign matter of some sort blocking the passage to the jet. To rectify this, start the engine and open the throttle, then momentarily block the air inlet by placing the hand over it, keeping the throttle open until the engine commences to race.

This trouble is not a frequent one with the S.U. carburetor owing to the size of the jet and petrol passages. When it does occur, however, the foreign matter can usually be cleared by the foregoing treatment, which, however, must not be abused, or damaging quantities of neat petrol will be sucked into the cylinders.

## Float-chamber Flooding

This is usually obvious from the quantity of petrol flowing over the float-chamber. Flooding is generally caused by foreign matter finding its way on to the seating of the float-chamber needle. This does not often occur, however, as the incoming petrol stream washes

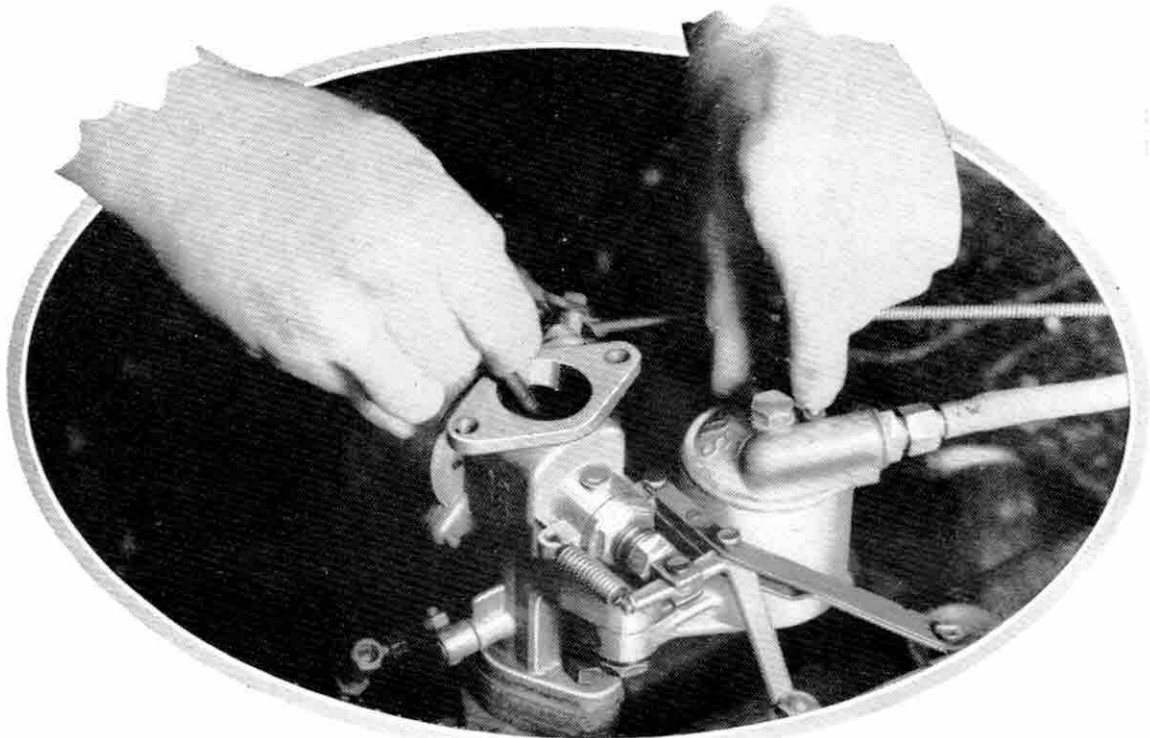

**Moving the piston aside with a small implement and flooding the float-chamber will enable the proper functioning of the jet to be observed.**



**The petrol feed pipe removed to show the filter**

away the particles of grit. When it does occur it may be remedied by removing the float-chamber cover and then twisting the needle on its seating a few times with the fingers ; the seating should on no account be ground in.

### **The Filter**

To ensure a free flow of petrol to the float-chamber the filter should occasionally be dismantled (every 5000 miles) and thoroughly cleaned. The filter is situated behind the union nut at the junction of the petrol pipe to the float-chamber lid, and is released by unscrewing the petrol pipe union. The filter should never be cleaned with rag ; always employ a stiff brush and petrol.

When replacing the filter remember that the helical spring is first introduced into the filter housing and that the thimble-like filter has its open end in contact with the hexagon union piece.

*NOTE.---We strongly advocate that owners should not modify their carburetors in any way. The jet and needle fitted as standard have been proved by extended tests to be the correct ones for best results, and nothing is to be gained by individual experiment.*

The Power Unit of the  
Wolseley 12/48

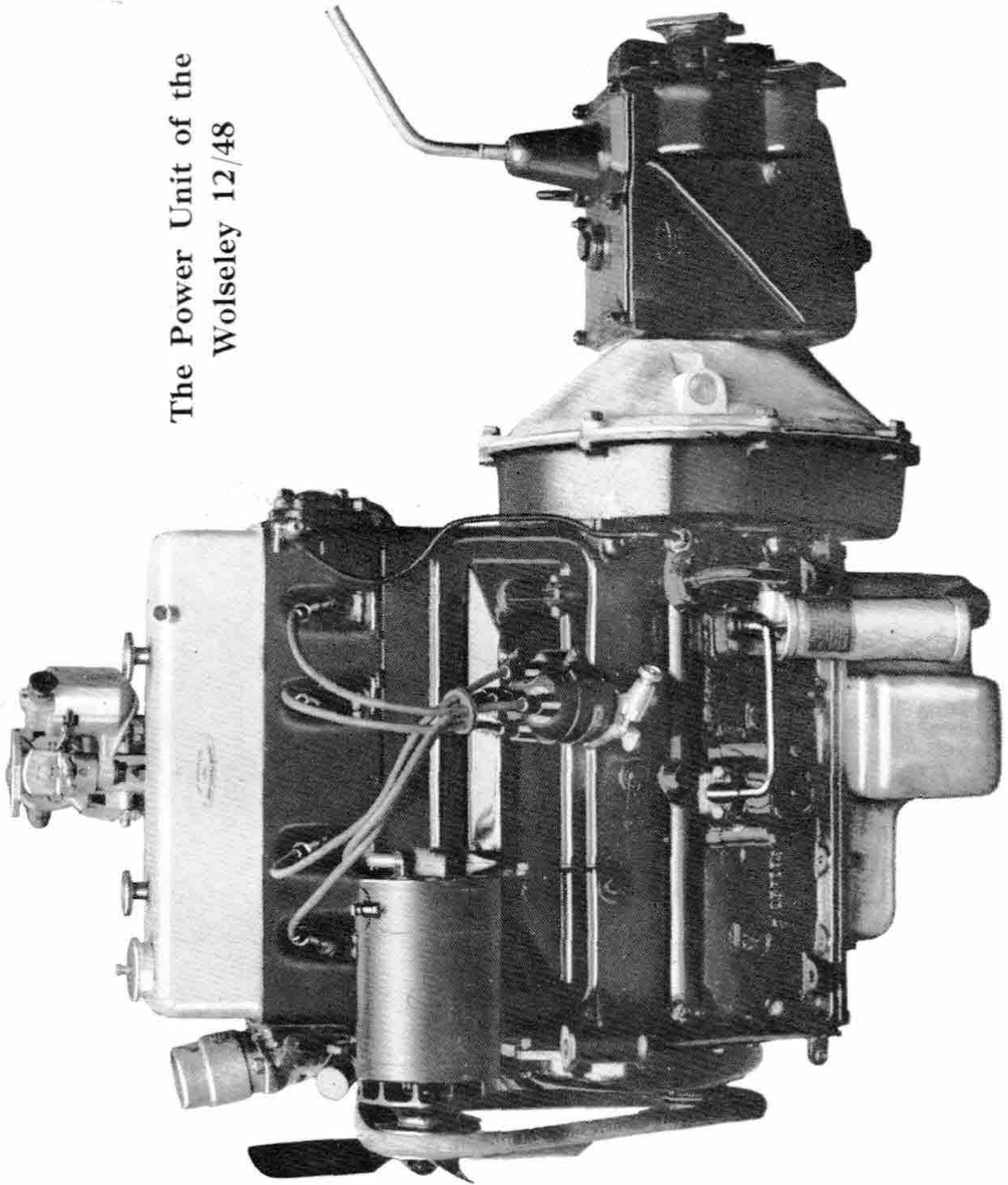



# S.U. Electrical Petrol Pump

## PRESSURE TYPE

THE single petrol pump of the Wolseley 10/40 and 12/48 is of the diaphragm type and its construction is such that it NN-ill give prolonged service with the minimum attention.

The only actual maintenance attention called for is the occasional removal and cleaning of the filter. The filter is inserted into the bottom of the pump body and can easily be withdrawn by unscrewing its hexagon attachment screws. When removed it should be thoroughly cleaned in petrol with a stiff brush, never use rag.

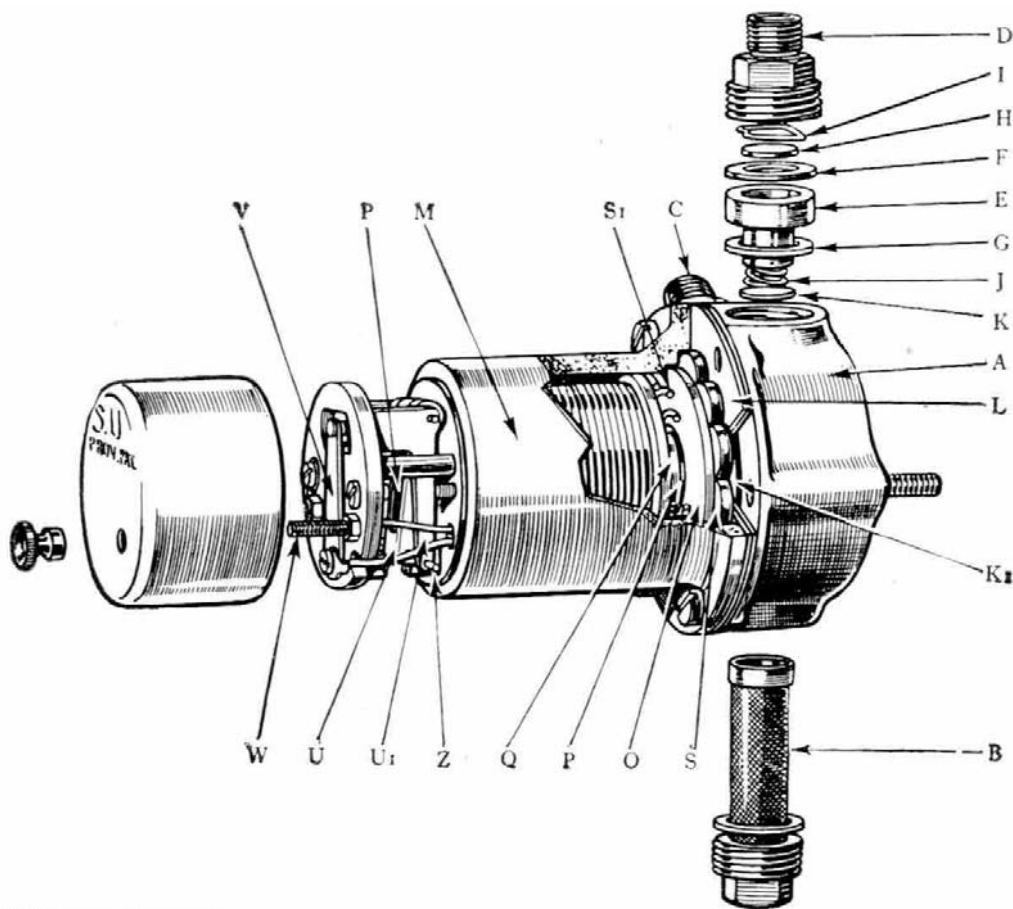

The S.U. electrical petrol pump in part section, showing salient feature

## Tracing Troubles

Should pump trouble be suspected, first disconnect the pump union of the pipe from the suspected pump to the carburetor and switch on the engine. If the pump functions the shortage is due either to blockage of the petrol pipe to the carburetor, or possibly to the carburetor float needle sticking up. If the pump will not function

after this has been done, first remove the filter " B " which is held in position by the brass hexagon nut at the base of the pump, and see if this is clear. Then disconnect the petrol pipe leading to the tank and blow down this with a tyre pump to ensure the pipe being absolutely- clear, and reconnect, the petrol pipe.

If the pump Still does not function or only works slowly, the stoppage may be due to a bad earth return, but this is very unlikely' as an earthing wire is included in the cable harness. To test for a bad earth connection, make definite metallic contact between the brass body of the pump " A " and the car chassis with a length of copper wire. To ensure a good earth it may be necessary to scrape off a small portion of the black enamel with which the chassis is coated. If the pump then functions normally, the copper earth wire connection should be cleaned and remade.

A bad connection in the pump itself may sometimes be traced to the nut on the terminal " W "inside the cover not being screwed down firmly.

Should these points be found in order but the pump still does not work, the trouble is in the pump itself and the cause will probably be too much tension on the diaphragm or blackened contact points, the cause of which is the tensioning of the diaphragm. The remedy is to clean the contacts by removing the cover from the contact points and pass a piece of thin card between the points when pressed together, so as to effect the necessary cleaning.

To release the tension on the diaphragm " L," remove the body M " from the base of the pump by undoing the small screws which hold these two parts together. The diaphragm itself will then be found to be adhered to the body of the pump, from which it will have to be separated. A knife will help in this operation, care being taken to prevent the rollers " S. " which support the diaphragm and act as a bearing, from falling out. The body should then be replaced on to the base, and the screws put in loosely, but before finally tightening up it is advisable to stretch the diaphragm to its highest possible position. This is effected by switching on the pump and holding the contact points together while well tightening up the screws. This will effect a permanent cure.

Should a pump work intermittently or not start clicking when switched oil in the morning, it is an indication that this trouble is occurring, and it should be given immediate attention to obviate final stoppage on the road.

### **The Filter**

The filter is situated at the bottom of the pump body and can be removed for cleaning purposes by unscrewing the hexagon plug holding it in position. It should be removed and cleaned in petrol with a stiff brush every 5000 miles. In order to withdraw the filter it is necessary to release the pump from its support bracket.

## **A Noisy Pump**

If the pump becomes noisy it is usually an indication that an air leak is taking place on the suction side of the pump. Check the level of the petrol in the tank and see that it is not too low ; also check all the unions and points, making sure that the filter union and inlet unions are quite airtight.

If the connection to the pullp is in order and the trouble persists, then it is probable that an air leak has developed somewhere in the petrol feed pipe between the tank and the pump. The best way to test whether this is so is to replace the feed pipe by a short length of temporary piping, the mouth of which can be inserted in a can of petrol. If the pump then functions properly\_ it is obvious that a leak has developed somewhere in the feed pipe.

## **Failure to Deliver Petrol**

Should the pump continue beating without delivering petrol it is very probable that some dirt has become lodged under one of the valves, in which case they should be dismantled by unscrewing the top or delivery union and lifting out the valve cage, when they can be cleaned and reassembled.

If, however, the pump struggles to pump and becomes very hot it is probable that the pipe line has become obstructed or that the filter has become clogged.

# THE BRAKE LAYOUT

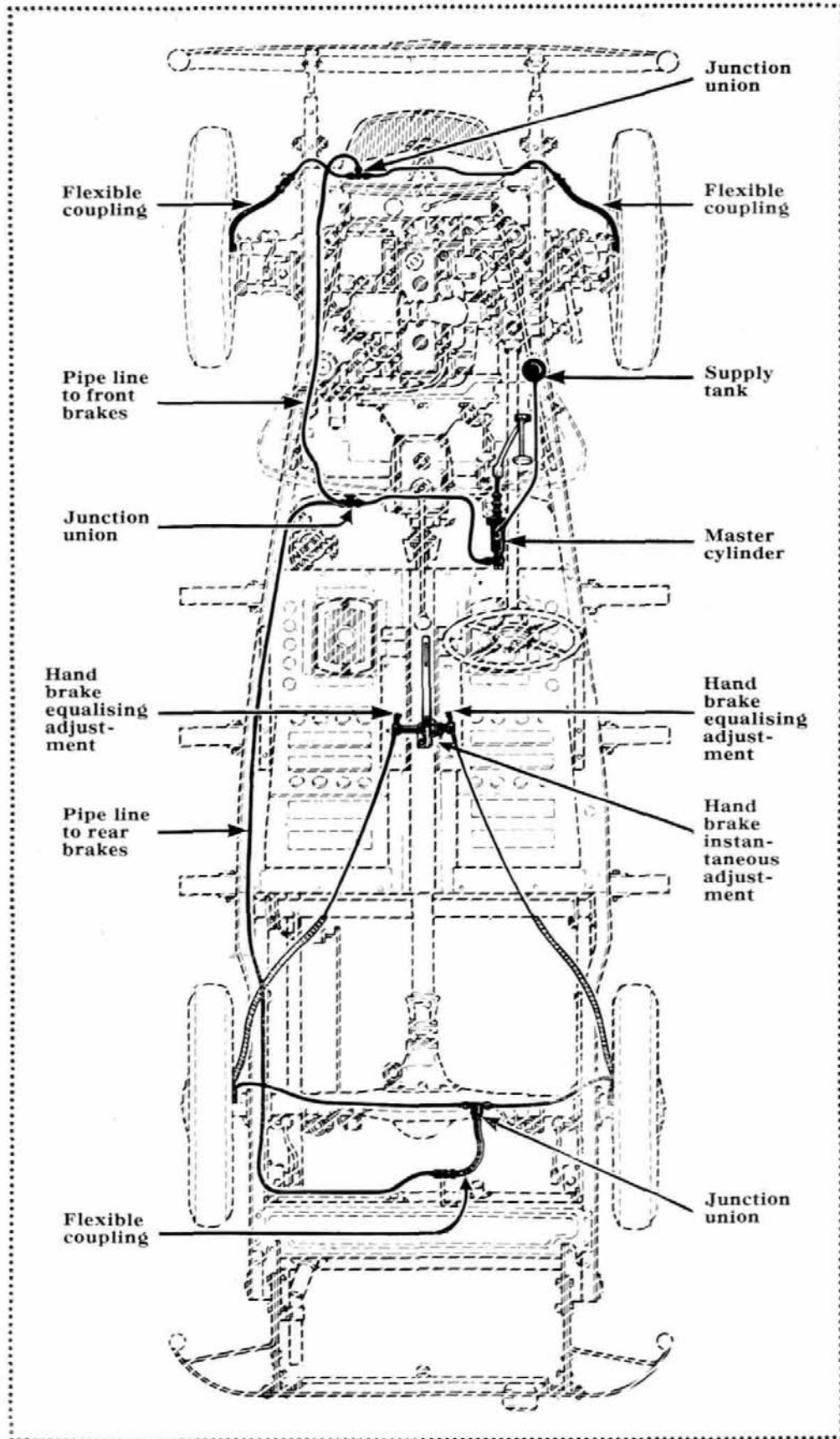

# The Hydraulic Brakes

## THEIR FUNCTIONING AND MAINTENANCE

THE foot brakes fitted to Wolseley 10/40 and 12/48 cars are of the self-equalising hydraulic type. They have no cross shafts, operating rods or hinged points to rattle or need lubrication. They are actuated by a master cylinder operated from the brake pedal. Pressure on the brake pedal is conveyed to fluid contained within the master cylinder and equally distributed by special pipe lines to each individual wheel brake.

### The Master Cylinder and Supply

These are of the automatically compensating type and maintain a constant volume of fluid in the brake system. Special expanders in all the cup joints ensure that the system is completely sealed and leak-proof

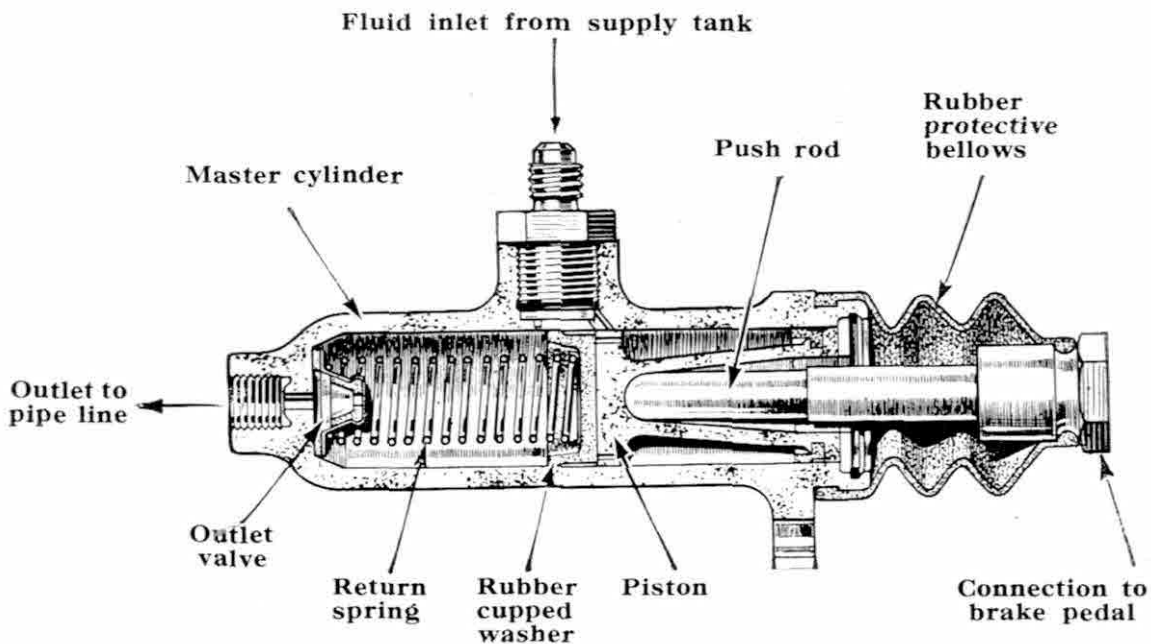

The master cylinder in section, showing its construction.

Provision is made automatically to compensate for expansion and contraction of the fluid in the system due to temperature changes.

The supply tank is mounted on the chassis and is merely a simple reservoir containing a sufficient quantity of fluid to feed the braking system under all conditions.

### The Wheel Cylinders

The wheel brake-shoe cylinders are open at both ends, rigidly attached to the brake back plates, and are each equipped with two opposed pistons with cup washers and push rods for connection to

the brake-shoe ends. The open mouths of these cylinders are covered with rubber boots to prevent the entry of dirt.

Since it is imperative that all air should be withdrawn from the braking system, provision is made at each wheel brake cylinder to expel any air which may be present in the pipe line. This consists of a "bleeder valve" with plug situated at the top of each cylinder immediately above the pipe line union.

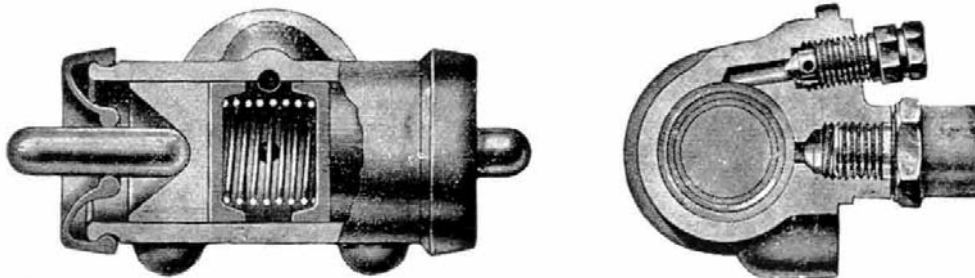

**Wheel cylinder details. The conical-ended bleeding screw and plug is clearly shown at the top of the right-hand illustration.**

### **The Pipe Line**

The pipe line is of stout gauge copper tubing, specially prepared and cleaned, and should not be replaced by piping of an inferior quality. Where spring deflection and steering movement must be provided for, special patent flexible hose connections are fitted. These, though flexible, are non-expandable, and are capable of withstanding a pressure of 6000 lb. per square inch.

### **Adjustments and Replenishments**

The brakes on all Wolseley cars are carefully adjusted before leaving the Works, and all Wolseley Dealers have instructions to check the brake adjustments before handing the car over to the purchaser. The brake mechanism should therefore require but little attention for a lengthy mileage. The supply tank filler cap should, however, be removed once a month and the level of the fluid checked. If it is found to be particularly low it is an indication that a leak has developed somewhere in the system, and it should be traced and rectified without delay. The supply tank should be about three-quarters full of fluid, and never less than half full. *Always use genuine Lockheed brake fluid.*

No equalisation adjustment is required, since the pressure applied to the shoes will always be precisely equal. It must be remembered, however, that the presence of oil, grease, or similar foreign matter on the braking surfaces will seriously affect the coefficient of friction, and in consequence the retarding effect on that particular brake, in spite of the fact that it is being applied with the same force as the others. In such cases it is necessary thoroughly to clean the brake lining with petrol, and slightly roughen its surface with a file.

The only adjustment required is that needed to compensate for the wear of the brake-shoe linings, and the frequency for such adjustment is, of course, dependent upon the character of the service to

which the brakes have been submitted. *During the first 500 miles, however, the maximum braking power may not be available, and adjustments may have to be carried out by the owner in order to take up the natural surface wear inevitable with new brake lining's.*

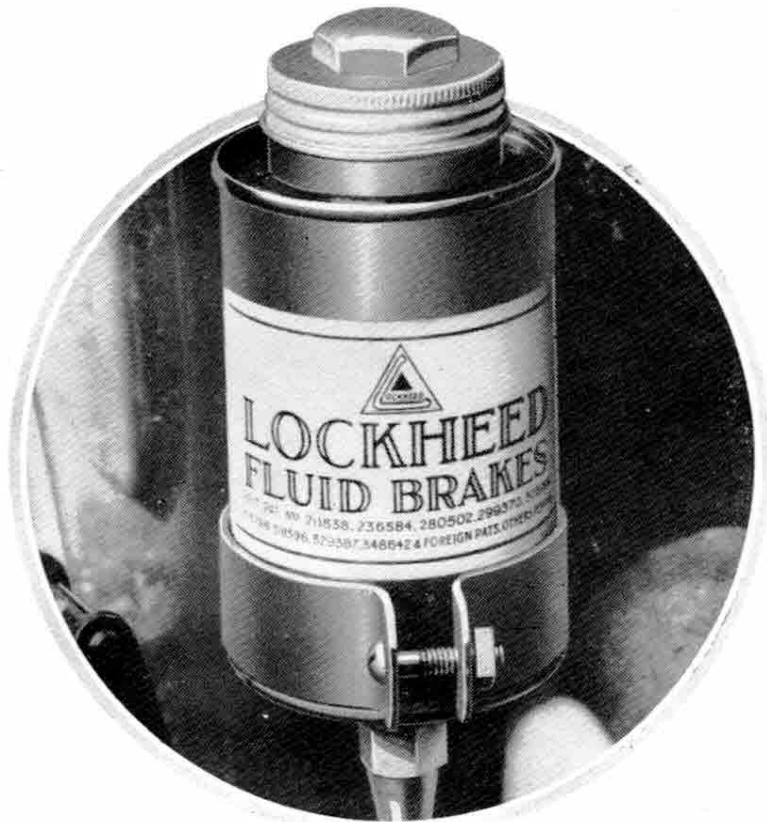

**The supply tank is carried on the dash.**

When linings have worn so far that the brake pedal has insufficient clearance from the floorboards, it is necessary to bring the brake-shoes in closer relation to the brake-drums. It is advisable to have at least  $\frac{1}{2}$  in. clearance between the head of the pedal and the floorboard when the brake is fully applied. Adjustment is effected by jacking each wheel in turn, spinning the wheel and partly rotating the hexagon adjustment bolts which are to be found on either side of the wheel cylinder until the brake-shoes just come into contact with the drums, then slackening back this adjustment until the wheel just rotates freely and without drag. The adjustment bolts operate snail-type cams bearing against the shoes and need only, a small movement. They are frictionally held and require no locking device ; they can easily be rotated with a spanner into the desired position. To bring the shoes closer to the drums the adjustment bolts should be rotated away from the centre of the wheel, and to bring the shoes farther away from the drums they should be rotated towards the centre of the wheel, With the spanner above the nut. when these operations have been carried out on all four wheels, all brakes should be in correct adjustment.

## Brake Linings

It is of importance that the brake linings of all brakes be of the same kind, or equalisation of the braking will not be achieved. Brake linings of the correct size and material can be supplied by your Wolseley Dealer.

If oil has been finding its way on to the brake linings from the axle it is probable that it has been passing the special oil-retaining device, and to obtain access to this it is necessary to remove the hub. Take care to see that this oil retainer is fitted the right way round, i.e. with the plain side of the metal housing towards the centre of the car.

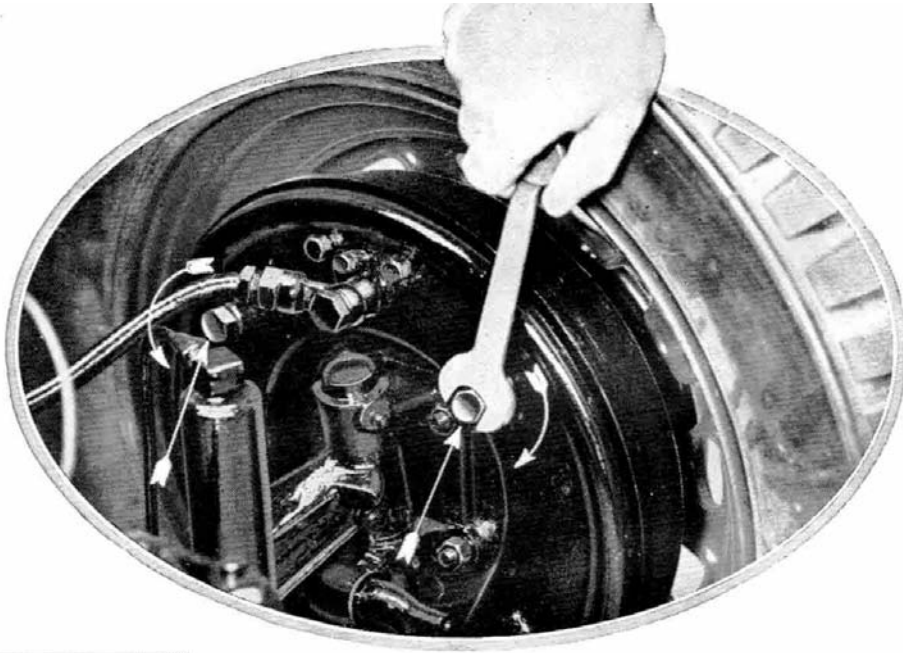

Here are shown the two shoe adjusting nuts to be found on each brake back plate. The small arrows indicate the direction in which they should be turned to bring the shoes closer to the drums.

## Access to Brake-shoes

If the brake linings require attention remove the wheel by taking off the domed wheel nuts, when the wheel will draw off. Next unscrew the three small countersunk-head screws in the brake-drum flange and draw off the brake-drum.

Removal of the brake-drum reveals the entire brake-shoe assembly, and the brake-shoes can now be detached for cleaning in the following way :

Unhook the brake retard springs from their anchorage to the brake-shoes. A piece of stout string or wire passed through the spring eye will greatly facilitate this. Remove the split pins and washers from the ends of the brake-shoe guide pins, and in the case of the rear brake release the upper end of the hand brake operating lever from the rear shoe by unscrewing the castellated nut retaining it to the toe of the shoe.



The shoes are released from the pivot pin by removing the horseshoe spring washer engaging the pivot pin, which when removed will allow the shoes to come away.

*Do not interfere with the wheel brake cylinders unless they are found to be leaking and obviously need attention, and do not operate the brake pedal while the drums are removed, or the wheel cylinder pistons may be forced out of their cylinders.*



#### **Left**

Here are clearly shown the three countersunk screws, spaced between the wheel studs, which have to be removed before the brake-drum can be withdrawn.

**Right .**  
The brake-drum removed showing the rear brake-shoe assembly. The assembly for the front shoes is identical, with the exception of the hand operating mechanism.

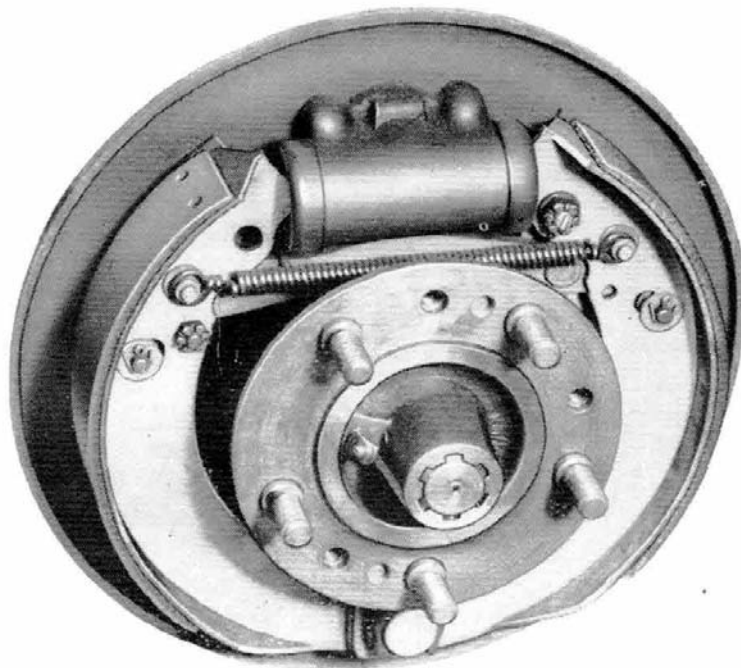

Brake re-lining should be entrusted to a competent Wolseley Dealer. During the first 500 miles after re-lining the maximum braking effect may not be available and adjustments may have to be carried out, at

fairly frequent intervals, by the owner in order to take up the natural surface wear inevitable with the new brake lining. (See Adjustments on page 46.)

### **Bleeding the System**

The process of bleeding is necessary whenever a portion of the system has been disconnected, thus permitting air to enter the fluid circuit. It consists of removing any air which may have found its way into the system. While this is not a difficult matter, it entails the use of special equipment to obtain the best results, and is at the best not a pleasant operation. Owners are therefore advised to entrust this work to an authorised Wolseley Dealer, who is also a Lockheed service agent.

**Instantaneous  
adjustment**

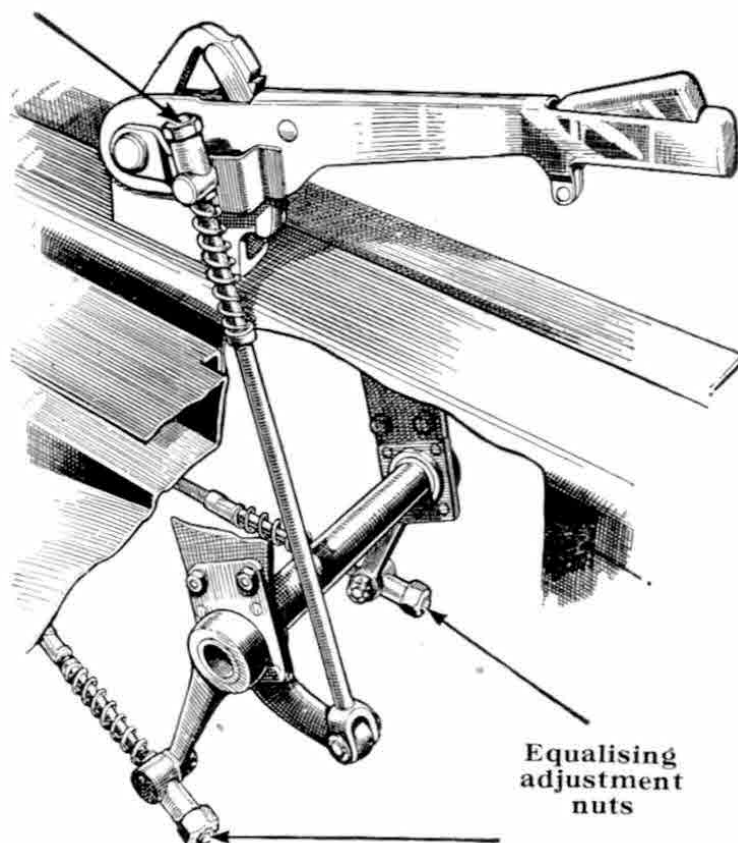

**Equalising  
adjustment  
nuts**

The instantaneous adjustment for the hand brake can here be seen close to the base of the hand lever. It adjusts both sets of rear brake-shoes in unison, and can be operated from the drivers's seat.

### **The Brake Fluid**

The Lockheed fluid used in the Wolseley 10/40 and 12/48 braking system is specially prepared for the purpose and it is important that no other fluid be introduced into the system for replenishment or

serious trouble will ensue. This special fluid, known as Lockheed Orange Fluid, is unaffected by high atmospheric temperatures, and is immune from freezing. Oil, petrol, paraffin and similar mediums are definitely injurious to some parts of the system and should on no account be introduced to the system or used for cleaning purposes. If it is required to clean any parts of the braking system they should be washed either in the special brake fluid supplied or alcohol. If alcohol is used, the parts should be well dried and treated with brake fluid before being replaced.

Lockheed fluid is stocked by all Wolseley Dealers.

### **Leakage of Brake Fluid**

Excessive consumption of brake fluid is an indication of a leak somewhere in the system. A leak may be traced by applying very heavy pressure to the brake pedal with the car stationary and checking over the various connections until the point of leakage is found.

Note.—The pistons of the wheel or master cylinders should never be removed. Special tools are required correctly to assemble these components and there is nothing in them to give trouble, provided only genuine Lockheed fluid is used. In cases of damage a complete cylinder replacement should be employed.

### **In Conclusion**

Don't use an substitute for Lockheed Orange fluid, or you will have trouble.

Don't permit grease, paint, oil or brake fluid to get into contact with the brake linings.

Don't use packing compounds for the joints ; only straight metal-to-metal joints should be made.

Don't use paraffin or petrol for cleaning purposes. Nothing but alcohol or brake fluid should be used.

Don't re-line one wheel with a different make of lining to that used on the others. Always use genuine Wolseley linings.

Don't allow the supply tank to become less than half full of brake fluid.

### **The Hand Brake**

The hand brake on the Wolseley 10/40 and 12/48 is centrally situated next to the gear lever and operates the shoes in the rear brake-drums by cable mechanism. Ample and simple equalization adjustment for the cables is provided at their junction to the brake countershaft levers.

(Care must be taken to see that both brakes are applied with equal force in order to obtain maximum braking efficiency, and whenever the adjustments provided at the junction of the cables to the brake countershaft levers are used the rear wheels must be jacked up and tested for equal resistance by turning them by hand. When using these adjustments the cable arrest be prevented from rotating by engaging the flats, provided on the end of the adjusting screw, with a spanner.

A main adjustment is provided, which adjusts both cables in unison, on the tipper end of the pull rod from the hand brake lever to the countershaft, which can be operated from the driving seat.

## WITHDRAWING THE AXLE SHAFTS

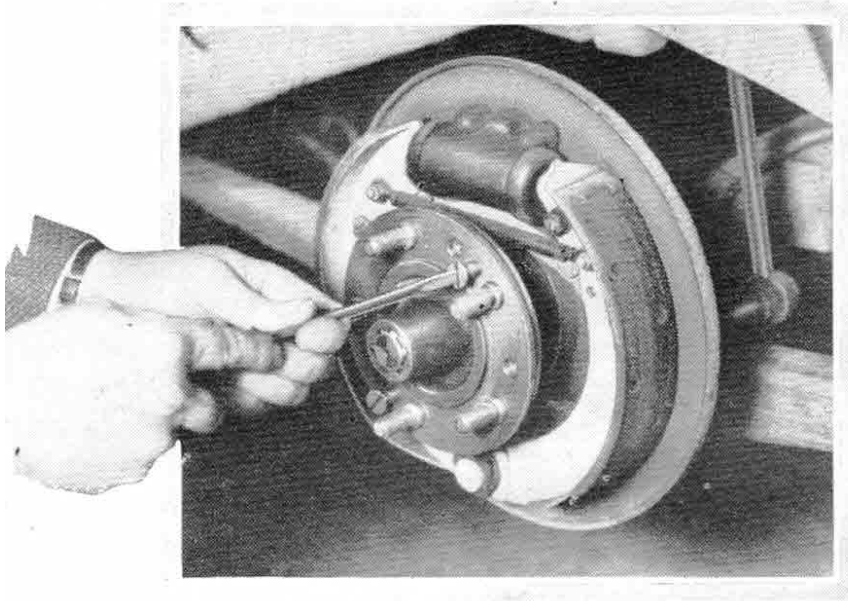

**ABOVE :—**Withdrawal of the brake-drum reveals the shoe assembly, including the hydraulic brake wheel cylinder. The shoes can now easily be inspected for condition. When it is required to withdraw the axle shaft, this can be done by inserting the two countersunk screws into the tapped holes indicated, and screwing them up alternately to part the flanges.

**BELOW :—**When the flanges are parted it is a simple matter to withdraw the axle shaft and axle flange assembly from the axle.

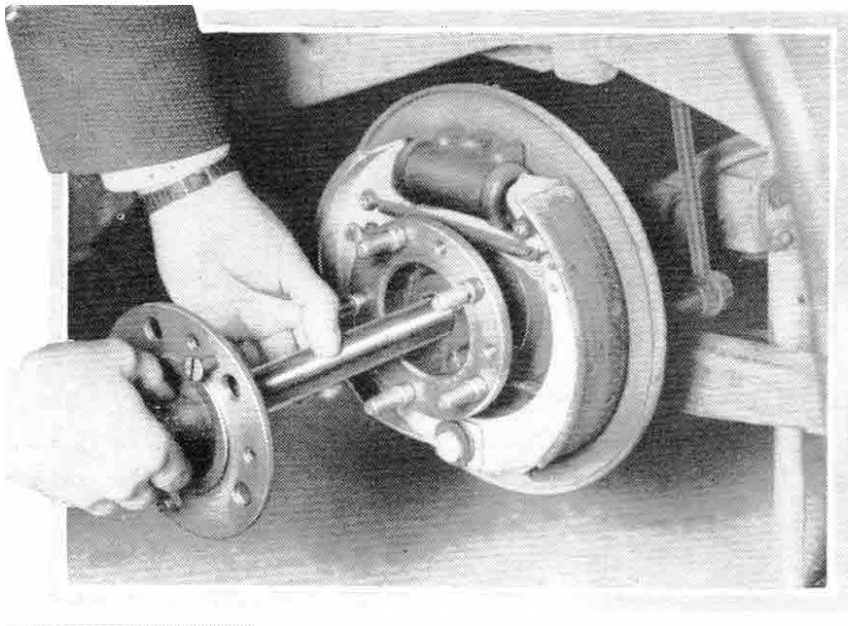

## Lubrication

CORRECT lubrication of any piece of mechanism is of paramount importance, and in no instance is it of greater importance than in the correct choice of lubricant for a motorcar engine.

It will be understood that all automobile engines have individual characteristics, such as operating temperatures, oiling systems, size of oil ways, clearances and similar technicalities, and it is therefore extremely important that an oil which is specifically suited to the needs of a particular engine should always be used.

With the object of enabling Wolseley owners and operators to obtain the best possible results from their cars, a high-grade superfine lubricant has been specifically prepared for Wolseley and certain other engines by Alexander Duckham and Co. Ltd., called Morrisol " Sirrom " (Regd.) Brand Engine Oil, and its use in Wolseley engines is recommended—indeed urged—by us because a long series of careful research and exacting tests have proved its superiority and entire suitability.

**The following is a list of the oils recommended.**

Engine.....	Morrisol " Sirrom " (Regd.) Brand Engine Oil.
Gearbox	Morrisol 11 Sirror " (Regd.) Brand Svnchro-Gear Oil.
Rear Axle ...	Morrisol " Sirrom " (Regd.) Brand X-S-Press Oil. Duckham's Special Wolseley Rear Axle Compound.
Steering Gear-box and Chassis Nipples	Morrisol " Sirrom " (Rebel.) Brand Transmission Oil.

When the above oils are not available we approve the use of the following makes

### **Important Note**

Before oil of a different make is used the Sump must be drained It is had practice and risky to mix lubricants in the sump.

### **Engine**

<i>Winter</i>	<i>Summer</i>
Duckhain's Aero N.P.3.	Duckham's Aero N.Y..
Double Shell	Triple Shell
Mobiloil A.	Mobiloil BR.
Patent Castrol AA.	Patent Castrol XL.
Filtrate Medium	Filtrate Ex. Heavy
Sternol WT W. Medium	Sternol WW. Medium Heavy
Motorine M.	Motorine M.
Essolube 40 Medium Heavy	Essolube io Heavy

### **Gearbox**

Duckham's Synchro-Gear Oil	Castrol S anshot
Mobiloil C«'.	Synchro-Filtrate
Golden Shell	Motorine Amber A.
	Essolube Gear Oil Medium

### **Rear Axle**

Duckham's XS-Press	Shell E.P. Spirax
Mobiloil E.P.	Filtrate Extreme Pressure Gear Oil
Castrol Hi-Press	
Essoleum Expee Compound 110	

### **Steering Gearbox and Chassis Nipples**

Duckham's Adcol Gear Oil N.	Castrol D Gear Oil
Shell Gear Oil	Filtrate Gear Oil
Mobiloil C.	Sternol Gear Oil
	Motorine Battersea A.
Esso Grease	

### **Engine**

The oil supply is carried in the sump of the engine. On the left-hand side of the valve gear cover an oil filler is fitted. An indicator rod, graduated at its lower end to give indication of the oil level of the sump, is fitted to a boss on the off-side of the crankcase. By drawing the indicator rod out the quantity of oil in the sump can be read off from where the oil adheres to the rod. When the oil level reaches the mark " full " on the indicator rod the sump contains i gallon 3 pints in the case of the 10/40 model, and 1 gallon 3 pints in the case

of the 12/48 model. After 250 miles the level should be checked and the loss should be replenished. The oil level should never be allowed to fall below the " low " mark.

In checking the quantity of the oil in the sump the car should be level and the rod should be withdrawn, wiped clean and reinserted before taking the reading. Owing to the surging and splashing of the oil when the engine and car are in motion an accurate reading is not otherwise possible.

An observant driver will pay as much attention to his supply of lubricating oil as to his petrol supply. Neglect of this results in harsh running and an overheated engine, loss of power, and, finally, " seizing-up " of pistons or bearings.

*When filling with oil it is imperative only to use perfectly clean oil, preferably that bought in sealed tins. Wolseley Motors Ltd. cannot hold themselves responsible under guarantee for crankshafts or bearings that are damaged or scored as the result of the use of dirty oil.*

The oil is drawn from the sump by a gear-type pump driven from the camshaft by helical gears and situated externally on the near-side of the crankcase.

After passing the pump the oil is delivered into a passage drilled in the pump casing, and then passes into an external filter, from which it passes into the internal main delivery- duct running the whole length of the engine, any excess oil delivered being by-passed back to the suction side of the pump through a release valve.

An oil lead is provided from the rear end of the oil gallery to the cylinder head, which lubricates the rocker-shaft bearings, and an additional pipe is connected to the oil gauge.

After use the oil gravitates back to the sump.

It will be found on first starting up the engine from cold that a high-pressure reading will be obtained on the oil gauge. This will gradually drop as the engine warms up and the oil becomes more fluid until a normal pressure of approximately 40-80 lb. per square inch will be indicated. Avoid racing the engine when first starting up while the oil is cold and thick. (See page 10.)

*Note.*—The automatic release in the pump deals with any excessive pressure when starting from cold. When hot, the pressure naturally drops as the oil becomes more fluid ; thus the reading on the gauge is dependent upon temperature ; furthermore—and this is very important—upon the condition of the oil itself.

Cold running is often the cause of serious oil dilution by petrol and a consequent drop in pressure. Under normal running conditions the pressure should not drop far below 40 on the gauge, whilst 10 at least should be shown when the engine is ticking over. New engines with new oil will of course give considerably higher readings than the above.

Oil which has been damaged by dilution —indicated by consistently low-pressure readings —should naturally be changed at once. For this reason, attention is called to the recommended change of oil after every 1000 miles.

## The Clutch

Oil from the rear crankshaft bearing finds its way into the clutch-case and lubricates all the moving parts automatically. The clutch chamber does not therefore need replenishing. Any excess of oil is returned to the sump filter by an oil trap and duct in the flywheel housing.

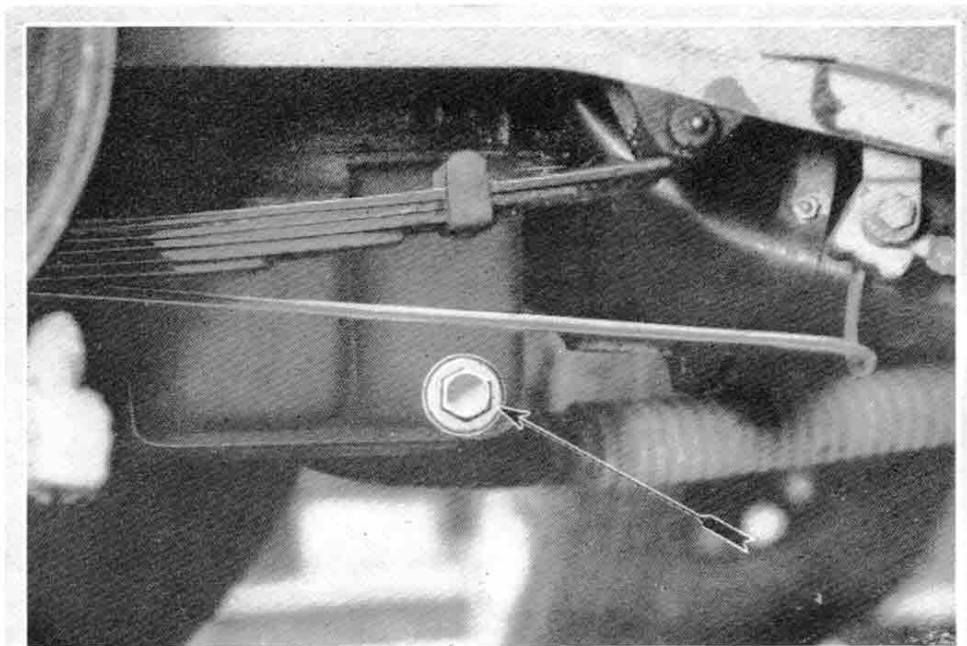

Here is shown the engine sump drain plug.

## Draining the Sump

We recommend that when the car has completed 1000 miles the oil in the sump and the gearbox should be drained to free them from any impurities that may have accumulated during the initial running-in process. Also, by reason of the fact that all oil loses some of its lubricating properties after it has been in use for a length of time, we recommend that the sump should be drained every 1000 miles after the first 500.

This operation is best carried out immediately the car returns from a journey, while the oil is still warm and fluid.

To drain the oil the following procedure is adopted : At the bottom of the engine on the near-side a brass drain plug will be found. Removal of this drain plug, will allow the oil to drain away. After removing the drain plug *we do not recommend that paraffin should be swilled through the engine or that the engine should be run without oil in the sump with the cover plate removed—either may lead to very serious damage.*

After carefully cleaning the drain plug, which will probably have an accumulation of dirt in its hollow centre, it may be replaced and screwed up tight. The engine may now be replenished with fresh oil through the oil filler.



If the engine is turned while the sump is drained, thus emptying the suction pipe, it may be necessary- to prime the pump through the opening exposed by disconnecting the delivery pipe to the external filter from its connection to the pump body.

### **Tecalemit External Oil Filter**

The engine oil is filtered before delivery by an external oil filter of the removable element type. It is situated in the lubrication circuit between the oil pump and the main internal delivery duct, on the left-hand side of the engine.

The filter element consists of felt-like filtering medium supported on a steel mesh frame housed in a cylindrical steel case bolted to the side of the crankcase. Oil is fed to it under pressure by the pump, and delivered to the engine in a thoroughly filtered condition.

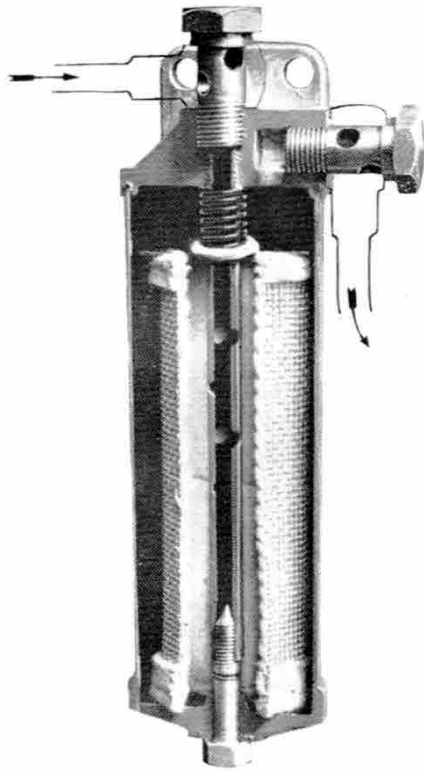

**The external oil filter is situated on the left-hand side of the engine, next to the oil pump. In the illustration it is partly cut away to show its internal construction.**

Every- 2000 miles the filter should be dismantled by unscrewing the hexagon-head bolt at the bottom of the cleaner. The container, with the element, is then thoroughly cleaned in petrol to remove all trace of accumulated impurities and dried before reassembly.

Care should be taken before assembly to see that the element slides freely over the central tube. Should there be any tendency for the element to bind, thus causing the valve seating spring to become coil bound, it should be carefully reshaped by hand, after which it should be replaced in the container, and the whole offered up to the head casting. The hexagon-head bolt at the bottom of the container should then be entered into the tube a few threads by hand until the top edge of the container engages truly with the annular groove and head cover joint. It is highly important that the container should engage freely in the 'groove and seat properly on the head cover joint.

In the final tightening operation, with the bolt at the bottom of the container, it should be noted that excessive spanner pressure is unnecessary, and in the event of there being leakage at the top cover joint with the bolt full-tightened, the container should be dismantled for further examination, and the joint faces carefully examined for any foreign matter which may be present on the joint surfaces.

The normal useful life of the filter element is 10,000 miles, and at the end of this mileage it should be removed and replaced by a new one.

New filter elements can be obtained from any Wolseley Dealer or Tecalemit Agent in sealed tins for carrying in the tool kit under Tecalemit Part No. OF.21804 for the 10/40 model and the 12/48 model, or under Part No. OF.1804 when paper wrapped.

An automatic pressure relief valve is provided in the cover just below the delivery pipe union. This consists of a spring-loaded disc closing the upper end of the filter element, which operates when the pressure within the filter element exceeds the predetermined maximum pressure.

If the intake and delivery pipes are disconnected at any time it must be remembered that the fiber washer should be between the nut and banjo and the copper asbestos washer between the banjo and the seating on the cover.

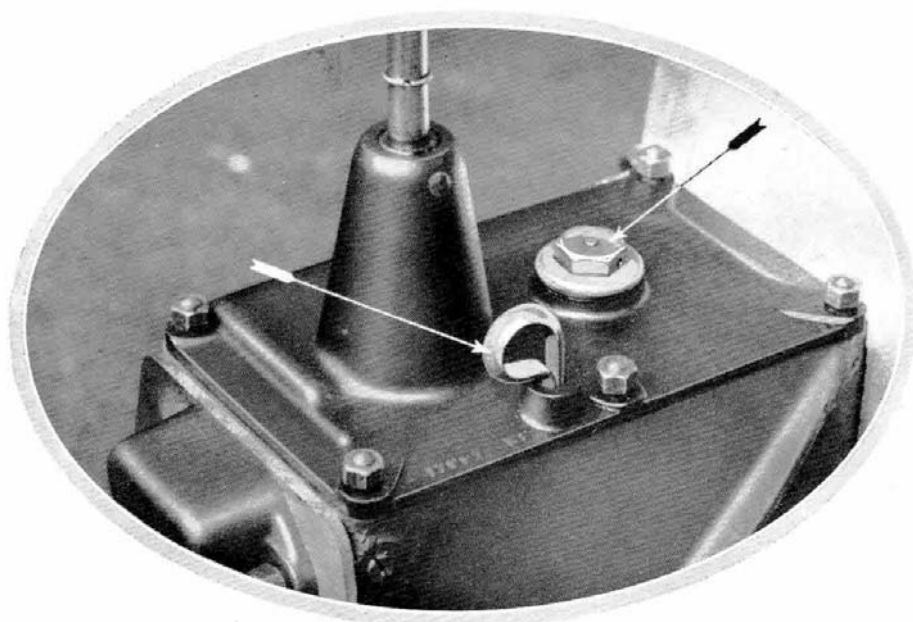

The oil filler and level dipstick for the gearbox are accessibly situated and easily reached by removing the rubber draught excluder.

## **Gearbox**

It is of the utmost importance to keep this full to the correct level, or harsh running of the gears will result.

The large filling plug is accessibly situated on the top of the gearbox. A dipstick on the right side of the gearbox provides indication of the correct oil level, which should reach the " normal " mark.

### **Draining the Gearbox**

It is advisable after the first 500 miles and subsequently every 5000 miles to drain off the old oil and refill the gearbox with fresh oil. Underneath the gearbox will be found a large plug. Removal of this will permit the gearbox oil to drain away. After draining; the oil replace this plug and remove the filling cap on the top of the gearbox and fill the gearbox with oil through the filler orifice up to the level indicated by the dipstick. This takes approximately 2 pints of oil on the 12/48 models and 2 pints on the 1040 models. Use 1Mlorrisol " Sirrom " (Read.) Brand Synchro Gear Oil.

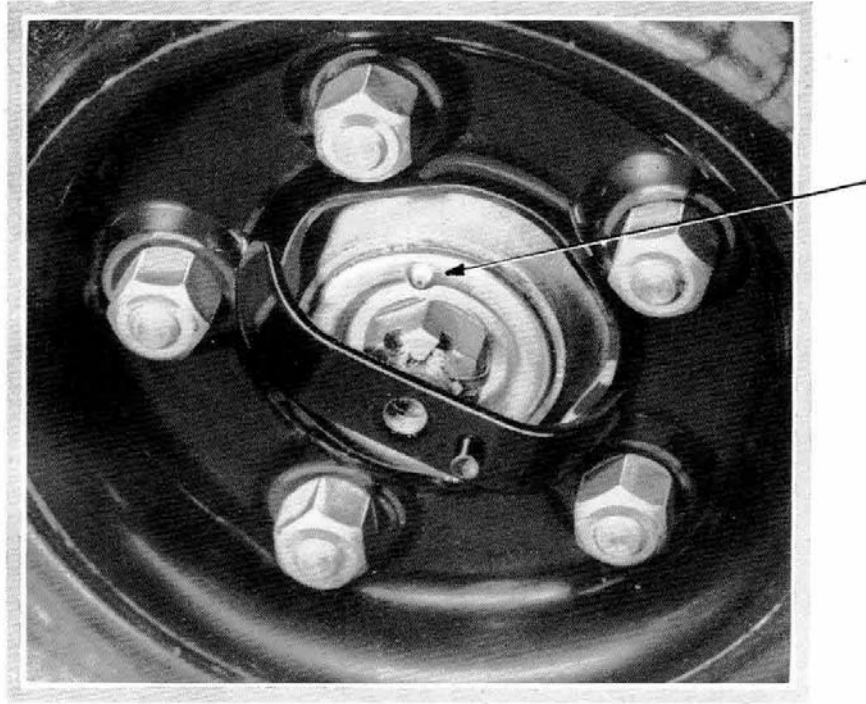

**The hub oiling nipple on the front hubs of the Wolseley 10/40 and 12/48.**

### **Wheel Hubs**

Every ;000 miles the wheel discs should be removed and the oilgun applied to the nipple exposed on the end of the hub. Not more than one stroke of the oilgun should be given or there is a danger of the excess oil finding its way on to the braking surfaces in spite of the oil seal.

### **Rear Axle**

This should be filled to the level indicated by the filler plug With 3 pints of oil, and this supply well kept up. Use Duckhaln's Special Wolseley Rear Axle Compound or \_llorrisol " Sirrom " (Regd.) Brand XS-Press Oil. While the car is new the rear axle should receive special attention ; anti it is advisable after the first ;00 miles, and thereafter every 5000 miles, to drain the old oil out by removing the drain plug situated underneath the axle.

After replacing the drain plug, refill with fresh oil. This is best accomplished upon returning from a lengthy journey, while the oil is still warm.

### **Chassis Lubrication and the Tecalemit Oilgun**

At all points of the chassis of Wolseley 10/40 and 12/48 cars that require lubrication the new type nipples are fitted, and in the tool kit will be found a Tecalemit oil-gun. This gun should be filled with Morrisol "Sirrom" (Regd.) Brand Transmission Oil by unscrewing the large cap on the end of the container and removing the automatic feed plunger by pulling the chain attached to it. When the gun is sufficiently full of oil, the plunger and end cap should

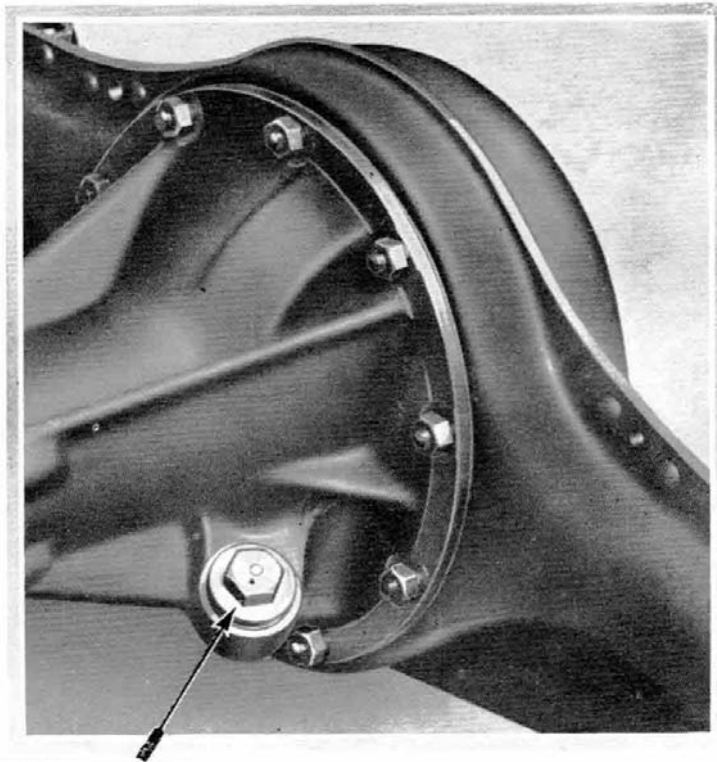

**This illustration indicates the combined oil filler and level plug on the rear axle.** be replaced. Removal of the cover on the other end of the gun displays an extension piece with a strong recoil spring surrounding it. This extension is really a type of high-pressure pump and it has at its end a recess with a hole in the centre. By applying this recess to the projection presented by a nipple and pushing the whole of the pump towards the nipple, oil will be forced under pressure into the bearing, and as soon as pressure is removed from the oilgun the extension «will be forced out again by its return spring, and the vacuum created will cause the automatic plunger to take up a new position read- for delivery of the next charge. This gun is particularly easy to handle and extremely effective in action. After using the gun replace the cap over the extension, screwing it up reasonably tight. This will prevent leakage of oil from the gun while it is not in use.

## **Fan**

An oil nipple is provided on the fan hub, to which the oilgun should be applied every 500 miles and given two strokes.

## **Water Impeller**

Every 3000 miles the lubricator of the water impeller should be given a few drops of engine oil. The water pump gland is of the carbon ring type and needs very little lubrication.

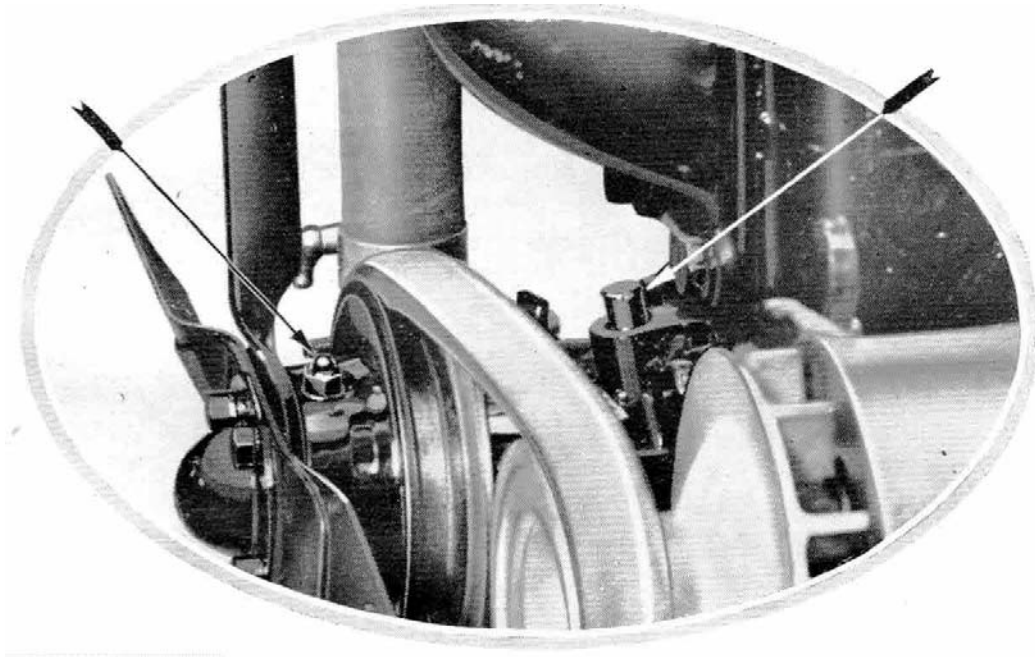

**The fan oiling nipple and water impeller oiler.**

## **Dynamo**

Every 5000 miles remove lubricator cap and, if necessary, refill with Vaseline.

## **Distributor**

Every 1000 miles two drops of good quality thin oil should be added to the distributor oiler.

Every 3000 miles the distributor rotating cam should be given a slight smear of Vaseline and the rotating arm withdrawn so that a few drops of good quality thin oil can be added in the opening to lubricate the cam spindle. Do not disturb the central screw.

Every 5000 miles place a spot of thin machine oil on the contact breaker rocker arm pivot.

Every 10,000 miles remove the distributor rotating arm and the distributor molded base. This will expose the automatic mechanism, which should be lubricated with engine oil.

## **Steering Gearbox and Steering Connections**

A hexagon plug is provided on the steering gearbox. Every 500 miles this should be removed and Morrisol " Sirrom " (Read.) Brand Transmission Oil poured into the opening until full.

The oilgun should be applied to the lubrication nipples of all the steering gear ball joints and the front axle knuckle pins every 500 miles and given three or four strokes.

## **Universal Joints (Propeller Shaft)**

The universal joints are provided with needle type bearings which are packed with grease on assembly and sealed. These bearings therefore need no lubrication attention.

## **Transmission**

A lubricating nipple is fitted to the fork of the front universal joint which serves to lubricate the propeller shaft sliding joint. The oilgun should be applied to this every 500 miles and given two strokes.

## **Brake Gear**

The foot brake gear being of the hydraulic type requires no attention in the matter of lubrication. All it needs is the periodical filling of the master cylinder reservoir with Lockheed fluid as detailed on page 46. Occasional free use of the oilcan is required at the function of the hand brake cables and pull rod to their respective levers and to the cable adjusting screw threads.

## **Bodywork**

Door lock bolt : Oil occasionally in oil hole.

Door hinges : Oil occasionally.

Seat slide runners : Grease lightly occasionally.

Sliding roof : Apply a few drops of thin oil with a rag on the side channels of the roof.

## SUMMARY OF LUBRICATION & ROUTINE ATTENTION

**After first 500 miles :** Tighten cylinder head stud nuts. Examine valve tappet clearances and adjust if inadequate. (Page 19.)

Drain old oil from engine ; do not wash this with paraffin but merely fill with fresh oil. Examine valve tappet clearance and adjust if inadequate. (See page 19.) Tighten body holding-down bolts.

**Every 250 miles :** Inspect oil level in engine crankcase. Refill if necessary. (See pages 3 and 54.)

**Every 500 miles :** Attach oilgun to all nipples and give pump three or four strokes. The nipples are situated as under :

10 on shackle pins, 2 on draglink, 2 on track rod, 4 on steering knuckles, 1 on fan, and 1 on propeller shaft sliding joint.

Remove plug on the steering gearbox and fill with oil.

See that wheel nuts are tight.

**Every 1000 miles :** Drain engine. Refill with fresh oil. Remove wheel hub caps and give one stroke of oilgun to nipple on end of hub.

Oil door lock bolts and hinges. Tighten door hinge fixing screws. Grease seat slide runners lightly. Apply a smear of oil on sliding roof channels.

Examine fluid level in hydraulic brake-gear supply tank and replenish if necessary. The tank should never be allowed to be less than half full of fluid or more than three-quarters full.

*USE ONLY GENUINE LOCKHEED ORANGE FLUID.*

Add one drop of thin oil to distributor and dynamo oiliers.

**Every 2000 miles :** Remove and clean external filter element.

**Every 3000 miles :** Give distributor rotating cam slight smear of Vaseline. Remove rotating arm and add a few drops of thin oil in opening. (Do not disturb scree-) Give a few drops of engine oil to water impeller lubricator.

**Every 5000 miles :** Clean mesh in air cleaner and re-oil.

Examine the gaps of the sparking plugs, and make sure that they are not too wide ; they should be .022 in.

Clean petrol filters at carburetor and petrol pump. Examine valve tappet clearance. (Page 19.)

Remove old oil from gearbox, rear axle, wash with paraffin and refill with fresh oil. (Pages 8 and icy.)

Inspect level in Jackall supply tank, replenish if necessary with genuine " Jackall " fluid only.

Add drop of thin oil to contact breaker pivot.

**Every 10,000 miles :** Examine valves and valve seatings, and scrape off carbon deposit from pistons and head.

Remove and clean sump. Replace oil filter element.

Tighten tip steering gear draglink ball joints. (Page 27.)

Tighten up spring seat bolts. (Page 17.)

Replenish shock absorbers with Luvax fluid if necessary.

Remove distributor base molding and lubricate automatic advance mechanism.

Renew sparking plugs.

## Care of the Tyres

Wolseley 10 /40 and 12/48 cars are fitted as standard with Dunlop cord tyres of the wired type. The reason for the selection of this make and type is that *special service* is given in those directions which matter to the owner.

When replacing tyres remember that the tyres have been accurately checked for balance at the `Forks and that the red spot on the wall of the tyre near the edge should coincide with the position of the valve. This ensures the maximum degree of balance of the complete wheel assembly.

The pressure at which tyres are run is most important, as the modern large section tyre is sensitive to its degree of inflation. The table given herewith should be adhered to rigidly, for which purpose we recommend that the owner should purchase a pressure gauge.

Once a tyre is punctured do not leave it on the spare wheel but have it repaired as soon as possible, or the advantage of the fifth wheel is lost. The spare wheel tyre should always be in repair and fully inflated.

Do not neglect the pressure until the tyres look as though they wanted more air, because by that time irreparable damage may have been done.

Test the pressure frequently in the spare as well as the running tyres, and restore any loss, even if only a matter of two or three pounds per square inch.

---

### RECOMMENDED TYRE PRESSURES FOR WOLSELEY 10/20 AND 12/48 CARS

		<i>minimum pressure :</i>		
		<i>lb. per sq. in.</i>		
		<i>Tyre size</i>	<i>Front</i>	<i>Rear</i>
10/40	... ..	5.75-16	22	25
12/48	... ..	5.75-16	22	25

Gauges for testing tyre pressures can be bought from all reputable motor dealers.



## TYRE FITTING AND REMOVAL INSTRUCTIONS



### **Special Note**

*Inextensible* wires are incorporated in the edges of wired type tyres. Therefore do not attempt to stretch the wire edges of the tyre cover over the rim edge.

Force is entirely unnecessary and may be dangerous, as it merely tends to damage the cover edges and serves no helpful purpose.

Fitting or removing will be quite easy if the wire edges are carefully adjusted into the rim base ; if it is not found to be easy the operation is not being correctly performed.

### **To Remove Tyre**

Remove all valve parts and push both cover edges into the base of the rim at the part diametrically opposite the valve, then lever the cover edges near the valve over the rim edge (see illustration above).

### **To Fit Tyre**

Push one edge of the cover over the edge of the rim. It will go quite easily if the part first put on is pushed right down into the rim base.

Very slightly inflate the inner tube—do not distend it—place it in the cover, with the valve through the hole in the rim. ("Take care that the valve, which is fitted in the side of the tube, is on the correct side of the rim.)

Fit the second edge of the cover, commencing at a point diametrically opposite the valve, and pushing the edge down into the base of the rim.

Small levers may be gently used to ease the last few inches over the rim edge.

Whilst inflating, see that the edges of the cover are seated evenly round the rim.

## TYRE VALVES

### Valve Cap

The valve caps fitted to each valve provide an air seal, preventing the ingress of dirt into the valve interior. By inserting the special key supplied in the tool kit into the mouth of the valve, it can be engaged with the valve interior for the purpose of unscrewing it.

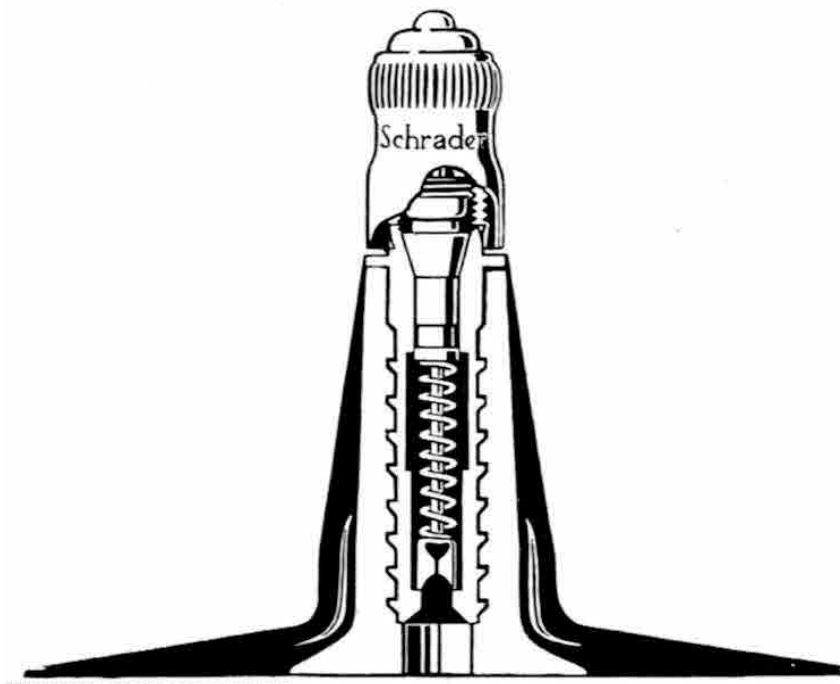

### Valve Interior

The air tightness of the valve depends upon the proper functioning of its "interior". It may be tested for air tightness by rotating the wheel until the valve is at the top and inserting its end in an eggcup full of water. If bubbles appear the seating is faulty. It should be removed and replaced by a new interior. It is advisable always to have spare interiors handy, and these are procurable suitably packed in small metal containers.

## Care of the Sparking Plug

ALL Wolseley 10/40 and 12/48 cars are fitted with Champion No. L10 extra range sparking plugs, a specially sectioned view of which is shown herewith. This particular plug has a 14 mm. thread.

The gap between the sparking plug points should be set between .022 and .025 inches. Too wide a gap will cause misfiring, especially at high speeds and under heavy pulling at low speed with an open throttle, while too small a gap causes poor idling. When adjusting gap move the side wire--never bend the centre wire

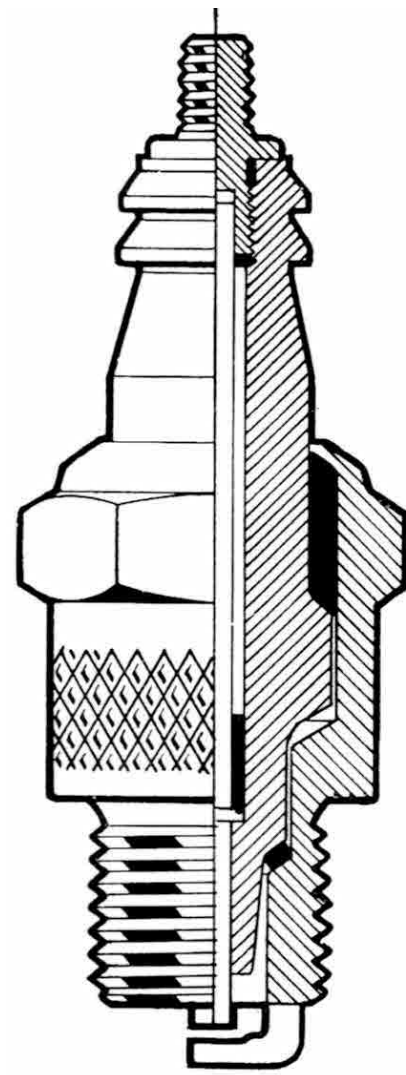

A partly sectioned view of the Champion sparking plug.

After the first several hundred miles of operation it will be necessary to clean the sparking plugs, for during the "wearing-in" process which is taking place in the car's early life, an excess amount of oil is generally used, and the slow-speed carburetor adjustment is a

little rich, with the result that carbon may deposit on the sparking plug insulator, causing a fouling condition. This soon disappears, however, when the motor has been well run-in and fresh oil introduced.

It must not be forgotten that the best of sparking plugs do not wear for ever. The intense stresses and strains imposed, especially in modern high-compression engines—often under conditions which



**Adjustments should be made only by the side wire, and the combined setting tool and gap gauge illustrated can be obtained from the Champion Sparking Plug Co. or your Wolseley Dealer for 4d.**

are not of the best—are so terrific that naturally- there is a gradual deterioration of the sparking plug. Inefficient functioning of the plugs means incomplete combustion in the engine cylinder, and incomplete combustion means unburnt gas going out of the exhaust. In this case the full heat value of the fuel is not used, and as a result power is lost and fuel is wasted. In this connection, therefore, it is recommended that sparking plugs should be replaced at intervals of 10,000 miles of service. By so doing you will restore power, speed, and save their cost many times over. Moreover, during the life of the plugs every considerate attention thereto will be repaid by unflinching service.

## Maintenance of the Hydraulic Shock Absorbers

THE Luvax shock absorbers fitted to the Wolseley 10/40 and 12/48 cars are of the hydraulic type and are designed to control the road springs both on compression and on recoil.

The shock absorbers incorporate constant pressure valves arranged to operate at a pre-determined pressure. These valves prevent the resistance of the shock absorbers rising too far, and they are situated in either the reacting block or the rotor. They are accurately set in the factory when being assembled and require no further adjustment. No adjustment screw is therefore provided in this type of shock absorber.

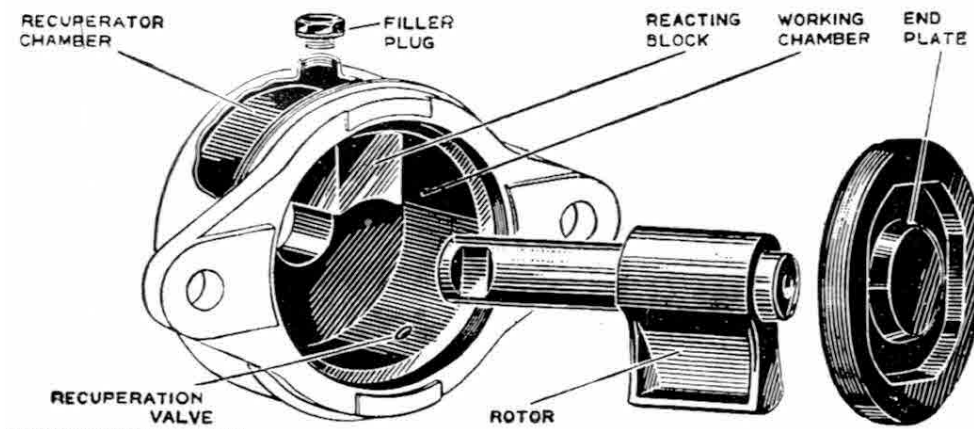

The component parts of the Luvax hydraulic shock absorbers separated to show their construction.

In order to ensure the proper functioning of this instrument, it is essential that the working chamber should always be completely full of fluid. The whole of the mechanism is therefore enclosed in another cylindrical chamber, or reservoir, in which is maintained a reserve supply of fluid. Any shortage of fluid in the working chamber is automatically made good through valves in the lower wall of the cylinder, and similarly any air which may be present is expelled through a special air duct in the top of the reaction block.

The oil valves fall automatically on to their seats when the shock absorber is doing no work, thus preventing loss of fluid or entry of air into the working cylinder.

### The Connecting Links

Tilting hearings are used in the connecting links between the lever arm and the spring. These bearings consist of round blocks of rubber which grip the hearing portion of the connecting link and obviate the use of ball joints. With this construction they do not require attention, such as lubrication, etc.

## **Replenishment**

Every 10,000 miles the recuperator chamber should be inspected by removing the tiller plug on the top of the case, and the fluid replenished if necessary.

*Use only Luvax Fluid.* It is a special grade of fluid whose properties have been carefully selected in order to comply with the conditions essential for efficient working at all times.

It can be obtained from -our Wolseley Dealer or any Lucas Service Depot in sealed cans with a special pouring spout.

The recuperator chamber must not on any account be allowed to become empty. Under these conditions, air will find its way into the working chamber and destroy the action of the shock absorber. At the same time it should not be overfilled.. When the recuperator is 3/4 full there is an ample supply of fluid.

# Tracing Troubles

## Motor will not Start

IF for any reason the motor fails to start readily when the starter switch is operated, do not keep it revolving for a long period, but release the starting switch at once. One of the following things may be the cause of the trouble :-

Your petrol supply may be exhausted.

The sparking plugs may be fouled with oil or carbon.

The high-tension lead from ignition coil to distributor may be loose, broken or damaged so as to leak.

The petrol pipe may be clogged or may have an air lock (indicated by petrol pumps laboring).

The battery may be run down (usually indicated by the slow speed at which the engine is turned).

The ignition coil may be defective.

The distributor points may be faulty and require resetting and cleaning.

The low-tension wire from coil to distributor and coil to ignition switch may be broken or faulty.

There may be water in the petrol feed.

In cold weather a low-grade petrol may cause difficult starting.

The petrol filters of the automatic petrol pumps or carburetors may be choked.

The automatic petrol pumps may not be functioning properly.

A carburetor piston may be sticking.

## Motor Misses at High Speeds Only

This may be occasioned by :-

Faulty sparking plugs which may be fouled or gaps not properly set.

Shortage of fuel due to dirt or obstructions in the petrol pipe, accumulation of dirt at filters, or petrol feed pump not working properly.

Improper functioning of inlet or exhaust valves (inlet valve indicated when spitting in carburetor takes place, exhaust valve when "banging" in silencer takes place).

Valve clearance may be badly set. Correct clearance .015 in.

One of the electrical connections may be loose, particularly in the high-tension lead between the coil and distributor.

Distributor contact breaker points badly set or dirty.

## Motor Misses at All Speeds

This may be due to :-

Faulty sparking plugs with an internal fault, such as oil on plug points, carbon deposit, or too wide a setting.

Faulty valve action due to incorrect setting of valve tappet clearance or valve sticking in guide.

Warped or badly pitted valves also arising from faulty setting of the tappet clearance.

Broken valve spring.

Insufficient fuel due to petrol filters being clogged. (See pages 39 and 42.)

One of the ignition wires may be loose and making intermittent connection, particularly that between coil and distributor.

Distributor points may not be functioning with regularity and in need of attention. (See page 76.)

Carburettor may be flooding, due to dirt on the needle valve seating, causing mixture to be too rich. (See page 37.)

### **Motor Misses at Low Speeds Only**

This may be due to :-

Valves not seating properly, due to faulty tappet setting or distortion. (See page 19.)

Air leaks in induction system, due to faulty joints between carburettor and induction pipe, or induction pipe and cylinder block. Check joint gaskets for soundness and tighten up all nuts.

Carburettor setting fault\ (refer to carburettor section, page 34).

Batter%\- run down and thus unable to supply sufficient current for ignition purposes.

### **Engine Stops Suddenly**

If the engine stops suddenly without making any further attempts to run :-

Examine carburettor and ascertain that float-chamber is receiving sufficient petrol supply. (Shortage of fuel is often indicated by one or two restarts before the engine finally stops or by spitting through the carburettor.)

Test flow from carburettor jet. (See page 37.)

Test spark at plug points by removing plug, resting on engine, and observing spark when motor is turned by hand.

If spark is weak or non-existent, check distributor lead connections to coil and distributor, check distributor contact breaker points, clean and reset, if necessary.

If the spark is still weak, test all electrical connections.

If the spark still remains weak, check coil.

### **Engine Spits through Carburettor**

This is usually an indication of a weak mixture.

Check fuel supply to carburettor float-chamber. Remove carburettor and automatic petrol pump filters, clean and replace.

It may be caused by air leaks in the induction system. Check over all joints in the induction manifold and tighten up nuts.



A sticking automatic distributor advance control may be the cause. Lubricate as indicated on page 77.

Faulty setting of the inlet valve tappet clearance, preventing valves from closing properly, also causes this trouble.

One or other of the inlet valves may be sticking in its guide (indicated by no compression in that cylinder).

Spark plug gaps too wide. Correct gap .022 in. to .025 in.

Engine not attained normal running temperature.

### **"Banging " in Silencer**

This is usually an indication of a faulty, exhaust valve which is not closing properly, due to a warped seating or faulty valve tappet clearance. It may also be due to the exhaust valve sticking in its guide. It may also be produced by faulty mixture supply, which is either much too rich or too weak.

If " banging " takes place in the silencer when proceeding downhill with the throttle closed, it is usually an indication that the throttle does not close sufficiently when the foot is taken off the accelerator pedal. The slow-running position of the throttles should be checked over and the carburetter setting checked.

### **Starter Motor does not Operate**

This may be caused by an exhausted battery, due to excessive use of the starter motor or the lights, and is the direct result of failure on the part of the owner to observe the recommendations made in the electrical section of this Manual. It may also be caused by broken or loose wires, either in the battery, the starting switch, or the starter motor. Therefore examine all terminals and wires carefully for looseness or damage. Corroded battery terminals sometimes produce poor contact and thus interfere with the functioning of the motor. Disconnect corroded battery terminals, thoroughly clean, and finally coat them with Vaseline.

The starting switch may be defective, in which case it should be checked by a Lucas Service Depot or a Wolseley Dealer.

### **Engine Lacks Power and is Sluggish**

This in a new car may be caused by general tightness of the engine and will wear off after the car has been used for approximately 1000 miles.

Faulty setting of the carburetter mixture control is also a source of trouble of this nature. (See page 34.)

Faulty action on the part of the automatic ignition control, due to lack of lubrication, may also be a cause of this trouble. Remove the distributor rotating arm and add one or two drops of thin machine oil in aperture. (Do not disturb screw.)

In an engine which has seen some use, sluggishness is an indication of excessive carbon deposit, particularly if accompanied by " pinking when the engine is pulling hard. It may also be occasioned by faulty valves or faulty valve clearances.

## **Motor Runs Hot**

Water supply in radiator too low. It is necessary always to have the water well covering the base of the upper tank.

Carburetor mixture control maintained at " rich " position for too long a period. The carburetor mixture control should be checked.

A carburetor which is set to deliver an excessively weak mixture is also a cause of overheating.

Hand brake has been left partly on or foot brake adjusted too closely.

Radiator thermostat not functioning properly.

Fan belt may be broken.

Automatic ignition control may be faulty and sticking. Lubricate as indicated in above paragraph.

## **Engine Knocks when Pulling Hard**

When an unusual sound emanates from the engine, investigate its cause immediately and do not continue running the engine in the hope that matters will right themselves. First of all ascertain that the oil gauge is registering the right pressure and that there is plenty of oil in the sump. Be sure that the noise is not due to shortage of lubricant.

The more general causes of engine knocks are

**1. An excessive accumulation of carbon deposit on the piston heads, valves and combustion chamber.** This state of affairs is indicated by a high-pitched metallic ring or " pinking " whenever the engine is made to pull hard. This develops gradually as the engine is further used and must not be confused with a similar noise produced by ignition which is too far advanced. When an engine is suffering from excessive carbon deposits, it will have a tendency to be sluggish, run rather hot, and labor heavily on gradients.

**2. Loose or worn bearings.**

The accurate diagnosis of knocks is a matter for an expert accustomed to the particular engine, and you are advised to consult your nearest Wolseley Dealer as soon as any unusual noise occurs.

*Remember it is bad policy to continue running a car if it is obviously faulty.* If the trouble is attended to early no damage need be done and the matter may be comparatively easily remedied, but if allowed to continue extensive damage may ensue.

*For dynamo, starter and lamp troubles refer to pages 95-97.*

## HOW TO LOCATE AND REMEDY IGNITION TROUBLE

<i>Condition</i>	<i>Method of Detection of Possible Causes</i>	<i>Remedy</i>
Engine Will not fire	Starter will not turn engine and lamps Do not give good light. Battery Discharged.	Start engine by hand. Battery should be recharged by running car for a long period during the day time. Alternately recharge from an independent electrical supply. (see also Page 80)
	Controls not set correctly for starting	See that ignition is switched on and Everything is in order for starting
	Remove cable from center distributor terminal and hold it about ¼" away from some metal part of the chassis while engine turned over. If it sparks jump gap regularly, the coil and distributor are functioning correctly	Examine the spark plugs, and if these are clean and the gaps correct (.5mm. or .022".), the trouble is due to carburetor, petrol supply, etc.
	The coil does not spark, the trouble may be due to any of the causes below :-	
	Faults in low tension wiring. Indicated by (1) No fluctuating movement of ammeter needle when engine is slowly turned and ignition switch is on, or (2) No spark occurs between the contact points when quickly separated by the fingers when the ignition switched is on.	Examine all the cables in the ignition circuit and see that all connections are tight and clean. See that battery terminals are secure
	Dirty or pitted contact points	Clean fine carborundum stone or emery cloth and afterwards with a cloth moistened with petrol
	Contact breaker out of adjustment, or arm sticking on pivot. Turn engine until are fully opened and test gap with gauge on spanner	Adjust gap to gauge. Clean rocker arm pivot and lubricate with one drop of oil
Engine misfires	Dirty or pitted contact points	Clean fine carborundum stone or emery cloth and afterwards with a cloth moistened with petrol
	Contact breaker out of adjustment. Turn engine until are fully opened and test gap with gauge on spanner	Adjust gap to gauge. Clean rocker arm pivot and lubricate with one drop of oil
	Remove each sparking plug in turn, rest it on the cylinder head and observe whether a spark occurs at the points when the engine is turned. Irregular sparking may be due to dirty plugs or faulty high tension cables If sparking is regular at all plugs, the trouble is probably due to engine defects	Clean plugs and adjust the gaps to about .022" (0.5mm) Replace any cable if the insulation shows signs of deterioration or cracking. Examine carburetor, petrol supply etc...

# Maintenance of the Lucas Coil Ignition System

## The Ignition Control

THE ignition distributor is provided with an automatic timing mechanism which varies the firing point according to the requirements of the engine.

The distributors are fitted with a micrometer adjustment which allows accurate adjustment, to suit local or temporary conditions, to be made simply by the movement of a knurled knob.

With a clean engine, and using first grade fuel, the micrometer scale should be set at " 0 " before timing, and the distributor set so that the points are just breaking with the piston at top dead centre in the case of both 10/40 and 12/48 models. (See page 13.)

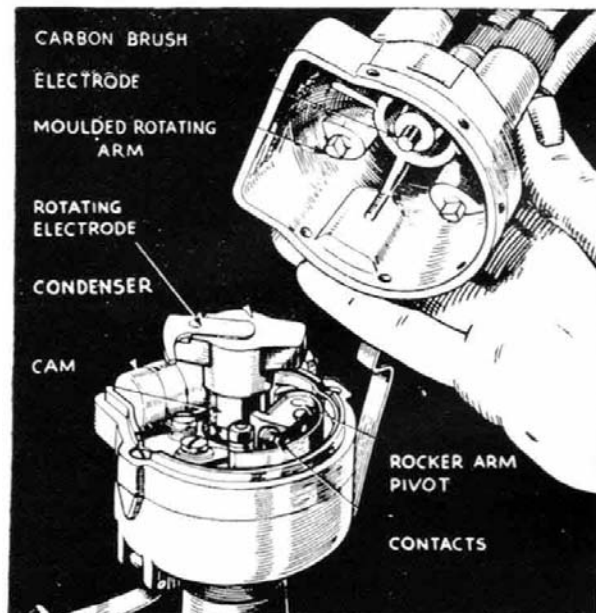

The Lucas distributor with cover removed to show its construction.

The final setting can be made by use of the micrometer adjustment after testing the car on the road. If the firing is found to be slightly too early or too late, adjust the knurled knob until the best engine performance is obtained. The adjustment should not be altered by more than one distributor degree at a time (one division on the scale is equivalent to two distributor degrees.)

## Lubrication

The following parts of the distributor require lubrication :-

1. *Distributor Shaft.* Add one or two drops of thin machine oil, through oiler provided, about every 1000 miles.

2. *Cam.* About every 3000 miles clean any accumulation of old grease from the heel of the rocker-arm and give the cam a smear of Vaseline.

3. *Automatic Tuning Control Mechanism.* About every 3000 miles withdraw the molded rotating arm from the top of the spindle by pulling it off, and add a few drops of thin machine oil. Do not remove the screw exposed to view as there is a clearance between the screw and the inner face of the spindle, through which the oil passes to lubricate the automatic timing control. Take care to refit the arm correctly and to push it on to the shaft as far as possible.

4. *Contact Breaker Pivot.* Every 5000 miles place a spot of thin machine oil on the pivot on which the contact breaker rocker-arm works.

### **Cleaning**

Keep the outside of the distributor clean, particularly the spaces between the high-tension terminals. Very occasionally remove the moulding by springing aside its two securing spring clips.

Wipe the inside clean with a dry cloth and see that the carbon brush is quite free in its holder. Clean the metal electrodes inside the moulding and also the rotating electrode on the distributor arm ; if necessary, use a cloth moistened with a drop of petrol for this. Make sure that all petrol has evaporated before replacing distributor cover.

-Next examine the contact breaker ; you must keep the contacts free from any grease or oil. If they are burned or blackened, clean them with fine carborundum stone, or if this is not available you can use very fine emery cloth. Finish off with a cloth moistened with petrol and remove all traces of dirt and metal dust. Misfiring is sometimes caused by dirty contacts.

### **Checking and Adjusting the Contacts**

Very occasionally you may need to adjust the contact gap. The chief cause of variation in the gap is wear of the heel of the contact rocker-arm which bears upon the actuating cam. Provided you keep the cam smeared with Vaseline, however (see lubrication instructions), the wear on the heel will be negligible and the contact gap setting should only require adjustment at infrequent intervals.

To check the setting turn the engine by hand until the contacts are fully opened. Now insert the gauge provided on the ignition screwdriver between the contacts. The gauge has a thickness of about 12 thousandths of an inch and it should be a sliding fit between the contacts when the gap is correct. We do not advise you to alter the setting unless there is quite an appreciable variation from the gauge. To make the adjustment keep the engine in the position to give maximum opening of the contacts and slacken the two screws securing the contact plate. Then move the plate until the gap is set to the thickness of the gauge. After making the adjustment care must be taken to tighten the locking screws. It is advisable to draw a clean

piece of paper between the points to remove all trace of dirt or grease left by the gauge.

### **Renewing the High-tension Cable**

The high-tension cables are those connecting the coil to the distributor and the distributor to the sparking plugs. If these cables should show signs of perishing or cracking they must be replaced by new mm. rubber-covered ignition cable. The method of connecting the cable is to thread the knurled moulded nut over the cable, bare the end of the cable for about 1 in., thread the wire through the metal washer provided and bend back the strands. Finally screw the nut right down into its respective terminal.

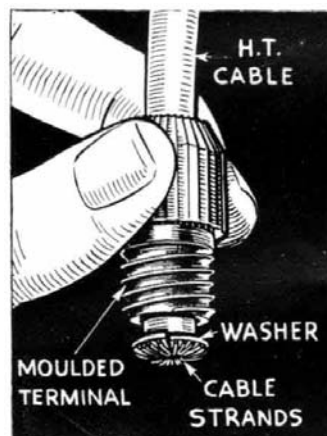

The method of securing the cable end to the distributor cover.

### **The Ignition Coil**

The coil requires no attention beyond keeping its exterior clean, particularly between the terminals, and occasionally checking the terminal connections to make sure that they are quite tight.

### **Ignition Switch and Warning Light**

The ignition switch, besides forming a means of stopping the engine, is provided for the purpose of preventing the battery being discharged by the current flowing through the coil windings when the engine is stopped. A warning lamp is provided in the instrument panel which gives a red light when the ignition is switched on and the engine is running slowly or is stationary, thus reminding you to switch off when the engine is at rest.

Should the warning lamp bulb burn out this will not in any way affect the ignition system, but you should replace it as soon as possible in order to safeguard your battery by warning you that it is being discharged.

The bulb used is a No. 252 M.E.S. 2.5 volt .5 watts.

### **Location and Remedy of Faults**

Although every precaution is taken to eliminate all possible causes of

trouble, failure may occasionally develop through lack of attention to the equipment or damage to the wiring. The most probable faults are tabulated, according to the symptoms displayed, in the fault-finding tables on the following pages.

It is recommended that a systematic examination is made by following the suggestions in the fault-finding tables, as the sources of many troubles are by no means obvious. In some cases, a considerable amount of deduction from the symptoms is needed before the cause of the trouble is disclosed.

For instance, the engine might not respond to the starter switch a hasty inference would be that the starter motor is at fault. However, as the motor is dependent on the batteries, it may be that the batteries are exhausted. This, in turn, may be due to the dynamo failing to charge, and the final cause of the trouble may be, perhaps, a loose terminal nut either at the batteries or elsewhere in the charging circuit.

If, after carrying out the examination, the cause of the trouble is not found, take the car to the nearest Lucas Service Depot for examination.

The fault-finding table for the ignition will be found on page 75.

# Running Instructions for the Lucas Starting and Lighting System

## Dynamo Lubrication

ALL dynamos are sent out from the Works with the bearings packed with grease. This lasts until the car is given its seasonal overhaul, when it is advisable to have the machine dismantled, preferably by a Lucas Service Depot, for cleaning and adjustment and repacking the bearings with grease.

Once every 5000 miles, unscrew the cap of the lubricator at the commutator end. If the lubricating wick shows signs of being dry, the cap must be refilled with Vaseline.

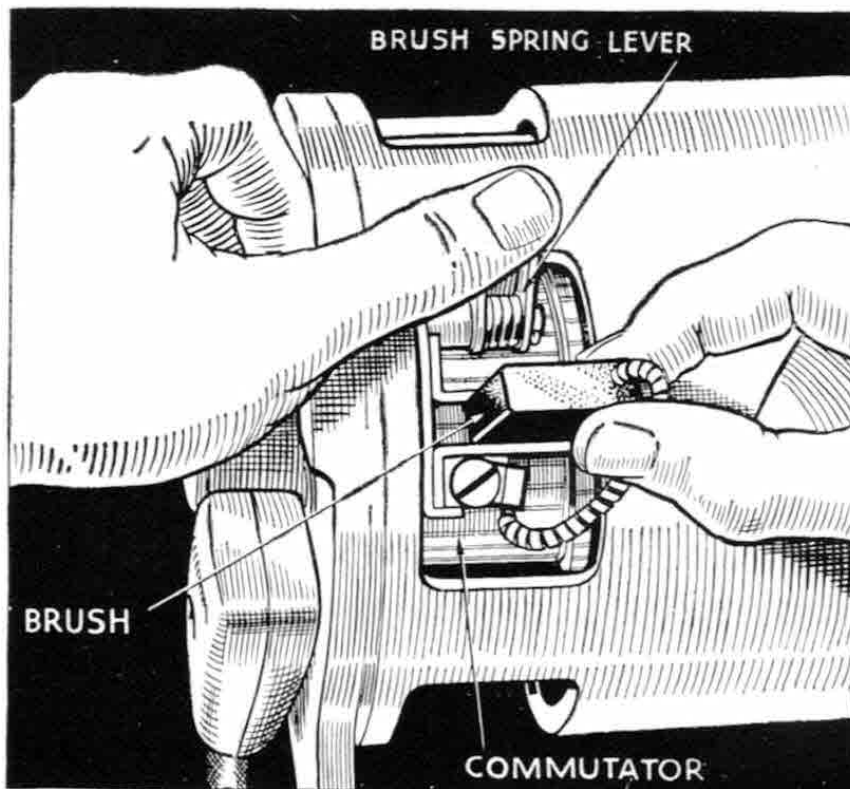

Withdrawing a dynamo brush.

## Inspection of Commutator and Brush Gear

About once a year, or every 10,000 miles, remove the metal cover from the dynamo for inspection of the commutator and the carbon brushes, as they are called. Take care not to lose the square nut when removing the cover fixing screw, as the cover is liable to spring open when the screw is released—the cover can be slid along the body of the machine after slackening the screw.

It is essential that the brushes make good, firm contact with the commutator. The brushes are held in boxes by spring levers. Hold



back the spring lever as shown, and at the same time move the brush to see that it is free to slide in its holder. If there are any signs of sticking, remove the brush from its box and clean both the brush and its box with a cloth moistened with petrol.

After removing brushes for cleaning or any other purpose, care must be taken to replace them in their original positions, otherwise they will not "bed" properly on the commutator.

If, after long service, the brushes have become worn to such an extent that they will not heat- properly on the commutator, they should be replaced. Always fit genuine Lucas brushes, as these are made specifically for their particular work in conjunction with the machines and will give the best results and the longest life. We advise you to have the brushes fitted at a Lucas Service Depot so that they can be properly "bedded" to the commutator.

Next examine the commutator. It should be clean and free from any trace of oil or dirt and should have a dull brown glazed appearance. The best way to clean a dirt- or blackened commutator is to slacken the drive belt, remove inspection cover, and pressing against the commutator a fine dry- duster and turning the dynamo over slowly by hand with the belt pulley. If the commutator is very dirt-, the cluster may be moistened with petrol.

### **Dynamo Output**

The dynamo output is accurately set before leaving the Works, to suit the requirements of the equipment fitted on your car, and in normal service the batteries will be kept in good condition. If, however, you should find that the batteries are not kept in a charged condition, or are being excessively overcharged, due to special running conditions, we advise you to consult the nearest Lucas Service Depot, where any necessary adjustments can be made. We do not recommend owners to attempt the adjustment themselves.

### **Ammeter Readings**

The ammeter, which is the upper instrument on the panel, indicates the amount of current passing into or out of the batteries. For instance, suppose the dynamo is generating 7 amperes at a particular speed and that some of the lamps are in use, taking, together with the ignition coil, 5 amperes, then 2 amperes are left for charging the batteries—this is the reading which will be given on the ammeter.

### **The Cut-out—an Automatic Dynamo Switch**

It will be noticed from the ammeter readings that the dynamo does not charge at very low engine speeds. This is because it is not rotating fast enough to generate sufficient energy to charge the battery.

Connected between the dynamo and the battery is the cut-out—an automatic switch which acts as a " valve," allowing the flow of current from the dynamo to the battery only. It closes when the dynamo is running fast enough to charge the battery, and opens when the speed is low or the engine is stationary, thus preventing current from flowing through the dynamo windings from the battery. The cut-out is located together with the fuses on the engine side of the dash.

## **THE STARTER**

### **When Starting**

Observe the following points when starting the engine :-

- (1) Operate the starter switch firmly, and of course release it as soon as the engine fires.
- (2) Never operate the starter when the engine is running. If the engine will not fire at once, allow it to come to rest before pressing the switch again.
- (3) Do not run the battery down by keeping the starter on when the engine will not start.
- (4) In cold weather starting will be facilitated by giving the engine a few turns by the starting handle before using the starter.

### **Cold Weather Starting—Relief for the Starter and the Battery**

In cold weather the starter's task is made much more difficult by the gummy state of the oil on the engine cylinder walls. You can, however, make this task very much lighter by giving the engine a few turns with the starting handle before using the electric starter. Another good plan is to hold down the clutch pedal while using the starter ; the starter does not then have to expend power in turning the gears in the gearbox.

If difficulty is encountered in starting the engine due to a run-down battery, it can, on emergency, sometimes be started in the following manner. Switch off the ignition and wait a few minutes for the battery to recuperate, then turn the engine by hand and get someone to switch on the ignition while you are still turning. As soon as the engine starts up open the throttle so that the dynamo cuts in and supplies the current.

### **Attention Needed by the Starter**

Give the starter commutator and brush gear similar attention to that described for the dynamo (see page 50).

The starter spindle projects from the starter and is provided with a square end which can be engaged with a spanner to free the pinion should it become jammed. To protect the spindle it is normally covered by a tubular sleeve which must be removed to expose the spindle itself

## THE BATTERIES

Two six-volt batteries, connected in series, are provided to supply the twelve-volt equipment.

Once a month unscrew the battery filler caps and pour a small quantity of distilled water into each of the cells (the separate compartments of the batteries) to bring the acid just level with the tops of the separators. This is done to replace water which has been lost by evaporation, and it is just as important as pumping air into your tyres, or refilling your radiator. You can obtain distilled water from any chemist and most garages. When examining the level of electrolyte avoid the use of a naked flame, as there is danger of explosion from the hydrogen gas evolved.



*Do not use tap water*, as it contains impurities detrimental to the battery. The best method of "topping-up" is to use a hydrometer, an instrument which looks rather like an oversized fountain pen filler and is used for measuring the state of charge of a battery.

Remember, it is only the water which evaporates, not the acid. If you do spill any acid, however, it should be replaced by sulphuric acid solution diluted to the same specific gravity as the acid in the cells. The specific gravity is measured by means of the hydrometer.

Keep the terminals clean and tight and well smeared with Vaseline. A liberal smearing of vaseline protects the terminals from the corrosive action of the acid. If allowed to continue, corrosion may eventually result in a breakage of the battery wiring. So do not forget cleanliness and the Vaseline! The positive terminal (marked +) of one of the two batteries must be in good electrical contact with the chassis frame. When inspecting the batteries, put a spanner on the bolt securing the cable end to the chassis frame in order to make sure that it is quite tight.

Keep the outside of the batteries clean and dry, particularly- the tops of the cells. Water and dirt form a conductor of electricity, and if such a path is allowed to form between the positive and negative terminals of the batteries there will be a leakage of current which will cause the batteries to run down. Give the cell tops a regular wipe over and you will avoid this.

Once a month make a point of examining the health of your batteries by taking hydrometer readings. This operation is quite simple and need not take long. There is no better way of ascertaining the state of charge of your batteries. The hydrometer enables you to " take a sample " of the acid solution. It contains a graduated float which indicates the specific gravity of the acid in the cell from which the sample has been taken. The following table gives the readings and their indications :-

Specific gravity 1.285 -1.300 Battery fully charged.  
1.210 Battery about half discharged.  
1.150 Battery fully discharged.

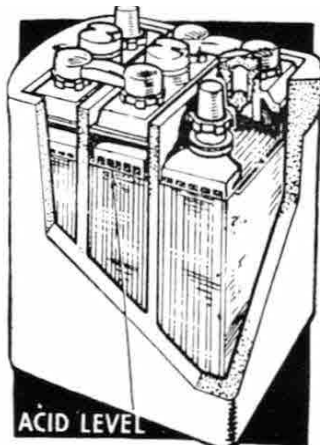

**One of the batteries in part section, showing the correct acid level.**

These figures are given assuming the temperature of the solution is about 60°F. For fuller particulars regarding temperature corrections see the " First Charge " instructions, a copy of which can be obtained from Messrs. Joseph Lucas Ltd. on application.

The readings for each of the cells (there are six cells) should be approximately the same. If one cell gives a very different reading from the rest it may be that acid has been spilled or has leaked from this particular cell, or there may be a short circuit between the plates. In this case we advise the owner to have his battery examined at a Lucas Service Depot—neglect may mean costly repairs later on.

It must be remembered that you cannot get more energy out of the batteries than is put in. If the car is left parked at night with the lights on, or if the starter motor is used excessively with very little daytime running, then the batteries may get in a low state of charge

—particularly in Winter. This may be remedied either by running the car for longer periods during daytime or by economising in the use of the headlamps and other accessories. If this is not possible, have the battery recharged from an independent electrical supply.

Never leave the batteries in a discharged condition for any length of time. This is very bad for them. In a sense it is like running a car on flat tyres. If the car is to be out of use for any length of time, see that the batteries are fully charged and about every fortnight give them a short refreshing charge from an independent supply of current to prevent any tendency to permanent sulphation of the plates.

Make a habit of keeping regularly to these instructions and your batteries will give you long and faithful service.

### **Keeping the Batteries Charged**

The batteries being the "reservoir" for the energy generated by the dynamo, there is no object in delivering further current to them once they are full. It is, however, always better to keep batteries overcharged rather than undercharged, but it should be remembered that extremes of overcharging or undercharging tend to shorten the life of the batteries. Obviously the amount of charging required will depend on the use of the car. If it is used for short runs in town, with consequent frequent use of the starter, the batteries will naturally require more charging than when it is used mainly for long distance runs. Then again, the demands on the batteries are generally greater in Winter than in Summer the lamps are more frequently used and the starter takes more current when turning over a cold engine.

In order to cater for these varying demands, the dynamo is arranged to give alternative outputs.

### **How to use the Charging Switch**

This switch has two positions—marked "Summer Half Charge" and "Winter Full Charge." The dynamo is arranged to give its maximum output whenever the headlamps are switched on. For cars running under average conditions, keep the switch in the appropriate position according to the season.

In some cases, where exceptional use is made of the lamps and starter in the Summer, causing the batteries to be in a low state of charge (hydrometer readings of 1.200 or under), run with the charging switch in the "high" or "full charge" position. On the other hand, if in Winter the car is used regularly during the day for long runs, with practically no night running, and the hydrometer readings are always found to be about 1.285, and the acid level gets unusually low, then it is probable that the batteries are being overcharged. In these circumstances, move the charging switch to the "low" or "half-charge" position.

## **WIRING AND THE PROTECTION OF THE EQUIPMENT BY FUSES**

The various units of the electrical equipment are connected together by cables which are bound together in a protective sheathing. The cables are coloured so that they can be identified on referring to the wiring diagram.

The equipment is wired on what is known as the single-pole system—that is to say-, one path for the current from the battery and dynamo to the various units is via the car frame or chassis. On the Wolseley 10/40 and 12/48 models it is the positive pole which is connected to the chassis.

### **Keep Terminals tight and remedy any signs of chafing Cables**

Occasionally examine the connections to the various units and see that they are quite tight. Particularly see that the battery connections are tight and free from corrosion and that the cable from the positive battery terminal is securely connected to the car chassis.

Inspect the cables for any signs of damage from vibration. Any part of the wiring showing signs of chafing must be bound with insulating tape. Take care that cables do not become saturated with petrol or oil, as this will cause them to deteriorate.

### **Wiring Additional Electrical Accessories**

Convenient supply terminals are provided in the cut-out and fuse-box for wiring additional electrical accessories. They are marked "Aux." and "E." Remove the appropriate fuse from its holder while making connections to the accessory terminals, to avoid any possibility of a short circuit. This fuse is marked "Aux."

To make efficient connections to the terminals, proceed as follows. Bare about 3 in. of the cable, twist the wire strands together and turn back about 18 in. so as to form a small ball. Remove the grub screw from the terminal and insert the wire so that the ball fits in the terminal post. Now replace and tighten the grub screw, this will compress the ball to make a good electrical connection. Do not leave any strands of wire projecting from the terminals.

### **Fuses**

For the same reason that fuses are provided in the electrical installation in a house so they are incorporated in your car equipment to protect the various unit, in the event of short circuits in the wiring, broken battery circuits, and other mishaps.

Those who have an electric supply in their homes will know what a fuse is, probably having had to replace one on more than one occasion. On your car the fuses are of what is known as the cartridge type, consisting of a glass tube with brass end caps enclosing a length of very fine wire which is soldered to the end caps. To replace a fuse, it is only necessary to withdraw the cartridge from the spring clips in which it fits, and then insert the replacement fuse cartridge in its place.

Spare fuses are provided in suitable holders, and it is important to use only the correct replacement fuse—the fusing value is marked on a coloured paper slip inside the glass tube.

We advise you to make yourself familiar with the various fuses on your car and the units protected by them, by a few minutes' study of the wiring diagram.



The appearance of a blown fuse.

A blown fuse will be indicated by the failure of all the units protected by it, and is confirmed by examination of the fuse if it has blown, as the broken ends of the wire will probably be visible inside the glass tube or there will be signs of burbling oil the identification strip. Before replacing a blown fuse, inspect the wiring of the units that have failed for evidence of short circuits or other faults that may have caused the fuse to blow, and remedy. If the new fuse blows immediately and the cause cannot be found, have the equipment examined by the nearest Lucas Service Depot.

### **"Dip-and-switch " Reflector Fuse**

The " dip-and-switch " reflectors are protected by a fuse which is incorporated at the back of the reflector together with a spare fuse. The indication of this fuse blowing will be the failure of the dipping reflector to function. The cause of the trouble may be a faulty connection inside the lamp, or it is possible that the cables may be fouling the reflector. The reflector can be rocked by the fingers without damage to the highly polished surface (any finger marks can be easily removed with a soft dry cloth). It is thus possible by rocking the reflector with the fingers to see if it is working freely, as sluggishness will cause the fuse to blow.

### **Cut-out and Fuse Box Type CFR2 Model L5**

This unit is mounted on the engine side of the dash and houses the cut-out and the two fuses protecting the dynamo field winding and the auxiliary accessories, e.g. the electric horn, windscreen wiper, etc. Spare fuses are provided as shown.

One fuse protects the accessories which are connected so that they operate whether the ignition switch is on or off, the other fuse protecting the dynamo field windings.

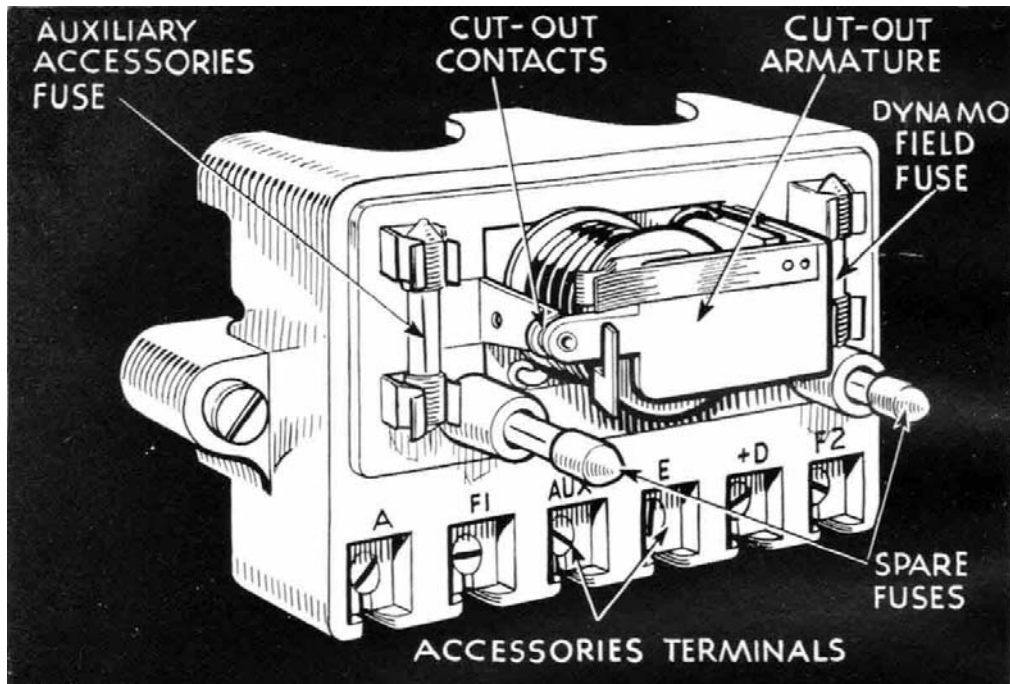

The cut-out anti fuse box with cover removed, showing the position of the auxiliary and dynamo field fuses and the spare fuses.

The cut-out and fuses are protected by a moulded cover which can be withdrawn by moving aside the securing spring clip.

The cut-out is accurately set before leaving the Works and must not be tampered with. Take care not to close the cut-out contacts when removing or replacing the cover, as this may cause damage to the equipment.

### Ignition Auxiliary Fuse Box. Type SF5

Mounted close to the cut-out is a small box containing a fuse. This fuse is fed from the ignition switch and is therefore controlled by the on-off position of the ignition key. Accessories connected to this fuse can only be operated when the ignition is switched on (e.g. stop lamp, Trafficators and windscreen wiper).



# LAMPS

## REMOVING HEADLAMP FRONTS AND REFLECTORS

### Removing Lamp Front

Slacken the single securing screw and move it downwards from the slot in which it fits. When replacing the front locate the top of the rim first, then press on at the bottom and tighten the fixing screw.

### Removing Reflector

Turn back ends of cork washer and remove screw in top of lamp. Turn reflector until markings " O " stamped on reflector rim and lamp body coincide ; the reflector can then be withdrawn.

When replacing reflector, engage it with the lamp body, then turn it until the screw hole in its rim is opposite to the left-hand screw hole on top of the lamp body. Secure reflector by means of screw.

### Side lamps

The front of the lamp can be removed by taking out the small screw in the top of the lamp body. Removal of the lamp front gives access to the interior of the lamp body for replacement of a bulb or attention to the cable connection.

### Fog Lamp

Slacken the fixing, screw at the bottom of the lamp and press down head of screw. The lamp front and reflector can then be withdrawn. The bulb holder can be withdrawn for bulb replacement when the two securing springs at the rear of the reflector are moved aside. When replacing, locate fixing screw in slot, then press front home and secure by tightening fixing screw.

### Stop-Tail and Reverse Lamps

The fronts of these lamps are secured by means of a fixing clip. Spring this back and the front opens quite easily.

### Panel Lamps

Panel lamps incorporated in instrument panels are accessible from the back of the panel.

The bulb holders can be released from the back of the panel for bulb replacements by pulling them out.

### Ignition Warning Lamp

The warning lamp bulb holder can be withdrawn by pulling it out from the back of the panel.

## ALIGNING AND FOCUSING LAMPS

### Checking the Alignment

The simplest way of checking the adjustment of the lamps is to take the car on a straight level stretch of road at night and examine the direction of the beams to see if they suit your particular requirements. If one appears to be out of alignment, adjust as follows  
Slacken the single fixing nut at the base of the lamp under the wing and move the lamp on its universal mounting to the required position, finally locking the adjustment by tightening the fixing nut.

### Focussing

To ensure that each lamp gives its best performance, the filament of the bulb must be as near as possible to the focus of the reflector. If the filament of the bulb is behind the focal point of the reflector the beam will be divergent, and if the filament is in front of the focal point the beam will be convergent, with a dark area in the centre of the beam. In either case, the lamps will have a poor range and will cause dazzle to approaching traffic.

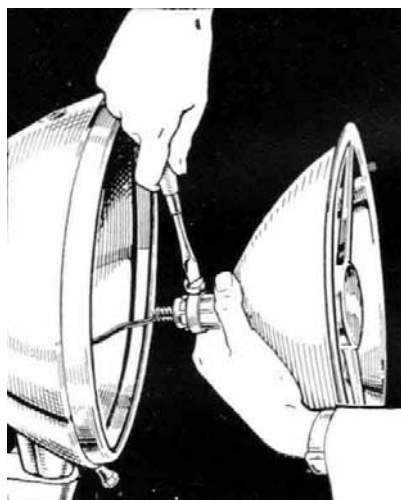

Here is shown the method of adjusting the focal position of the headlamp bulb.

Before lamps are dispatched from the Works, the bulbs are carefully focussed to give the best results. Provided that official Lucas bulbs are fitted as replacements, it should not be necessary to disturb the setting. If for any reason these are not obtainable, and other bulbs have to be fitted, it may be necessary to refocus as follows :-

Focussing involves moving the bulb backwards or forwards along the axis of the reflector until the best lighting is obtained.

Cover up one lamp while testing the other. If the lamp does not give a uniform long-range beam without any dark centre the bulb needs adjusting. To do this, remove the front and reflector, and slacken the clamping clip at the back of the reflector. This will release the bulb holder which can then be moved into the desired position.

After each adjustment, note the effect with the reflector and front refitted.

When the best position for the bulb holder has been found, see that the clamping screw is tightened.

### Dipping Reflectors

The headlamps are fitted with an electrically-operated "dip-and-switch" device. With this arrangement the near-side reflector is arranged to dip to the left and at the same time the off-side lamp is switched off.

The dipping mechanism calls for no attention whatever. There is nothing to adjust and no lubrication is required.

### Changing Over for the Right-hand Rule of the Road

In countries where the rule of the road is right-hand (instead of left-hand as in the United Kingdom), the dipping reflector can be arranged to dip vertically.

Reflectors are located to the lamp body by a screw at the top of the reflector rim and there is an alternative screw hole for use when the reflector is required to dip vertically. The Biflex bar of the reflector can be dealt with similarly as there are an extra pair of slots for the purpose.

If the cars fitted with "dip-and-switch" reflectors are to be used for any length of time in countries where the rule of the road is right-hand, it is advisable to interchange the headlamp reflectors. This involves slight modifications to the wiring, which are best carried out at a Lucas Service Depot.

### Lucas Genuine Spare Bulbs

Lucas genuine spare bulbs are sold by any reputable garage and are specially tested to check that the filament is in the correct position to give the best results with the lamps. To assist in the identification, Lucas bulbs are marked on the metal cap with a number. When fitting a replacement see that it is the same number as the original bulb.

We advise you to replace bulbs after long service before they actually burn out, as very often the filaments sag, making it impossible for them to be focussed correctly.

### Replacement Bulbs

<i>For</i>	<i>No.</i>	<i>Voltage</i>	<i>Watts.</i>
Headlamps ... ..	Lucas No. 54	12	36
Side, Tail, Roof and Stop Lamps	Lucas No. 207	12	6
Ignition Warning Light ...	MES No. 252	2.5	.5
Trafficators ... ..	Lucas No. 256	12	3
Fog Lamp ... ..	Lucas No. 28	12	36
Reverse Lamp ... ..	Lucas No. 1	12	24
Panel Lamps ... ..	MES No. 122	12	2.4
Radiator Badge ... ..	Lucas No. 251	12	6

## **Cleaning Lamps**

All Lucas reflectors are protected by a fine transparent and colourless covering which enables any accidental finger marks to be removed with chamois leather or a soft cloth without affecting the surface of the reflector. Never use metal polishes on Lucas reflectors. A light polish with a soft cloth is all that is necessary. Chromium-plated lamps will not tarnish and only need wiping over with a damp cloth occasionally to remove dust or dirt.

## **HOW TO OPERATE YOUR WIPER**

The windscreen wiper requires practically no attention ; all moving parts are packed with grease during assembly and no adjustment is required.

If the rubber blades become worn or perished they can be easily replaced at very small cost.

To start the wiper pull out the handle and turn to disengage it from the switch. Then move switch to "ON" position. To stop the wiper move switch to " OFF " position, pull out handle to disengage wiper blade from the gears, and turn the end of the handle into the top of the switch control.

## **ELECTRIC HORN**

All horns, before being passed out of the Works, are adjusted to give their best performance and will give a long period of service without any attention ; no subsequent adjustment is required.

If a horn becomes uncertain in its action, giving only a choking sound or does not vibrate, it does not follow that the horn has broken down. First ascertain that the trouble is not due to some outside source, e.g. a discharged battery, or a loose connection or short circuit in the wiring of the horn ; a short circuit in the horn wiring will cause the fuse to blow (see page 86.)

It is also possible that the performance of a horn may be upset by the fixing bolt working loose.

If the note is still unsatisfactory do not attempt to dismantle any part of the horn, but return it to a Lucas Service Depot for examination.

## " TRAFFICATORS "

### Lubrication

Every two or three months, or if the arms become stiff at any time, raise each arm and by means of a brush, matchstick or other suitable article, apply a drop of thin machine oil, such as sewing machine or typewriter oil, to the catch pin between the arm and the operating mechanism. Only the merest drop of oil should be used—any excess may affect the working of the operating mechanism. The " Trafficators " are kept in the closed position by means of a spring. The arms can be pulled out by hand. If any difficulty is experienced, switch the " Trafficator " on and then, supporting the arm in a horizontal position, move the switch to the " off " position.

### Replacing a "Trafficator" Bulb

If at any time the arm fails to light up when in operation, raise the arm in the manner described above and examine the bulb, replacing it, if necessary, with one of the same size and wattage as fitted originally.

Withdraw the screw on the underside of the arm and slide off the metal plate ; the burnt-out bulb can then be replaced. To replace the metal plate, slide it on in an upwards direction, so that the side plates engage with the slots on the underside of the spindle bearing. Finally, secure the plate by means of its fixing screw.

### Replacement Bulb

Lucas No. 256 (3 watt festoon).

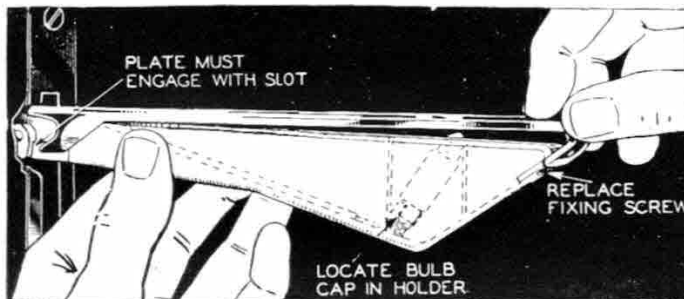

"Trafficator" Warning Lamp – Replacing bulb



Right:-- Lubricating the "Trafficator."

# Wiring Diagram of the Lucas 12-volt Electric Lighting, Starting and Coil Ignition Equipment on the Wolseley 10/40 h.p. and 12/48 h.p.

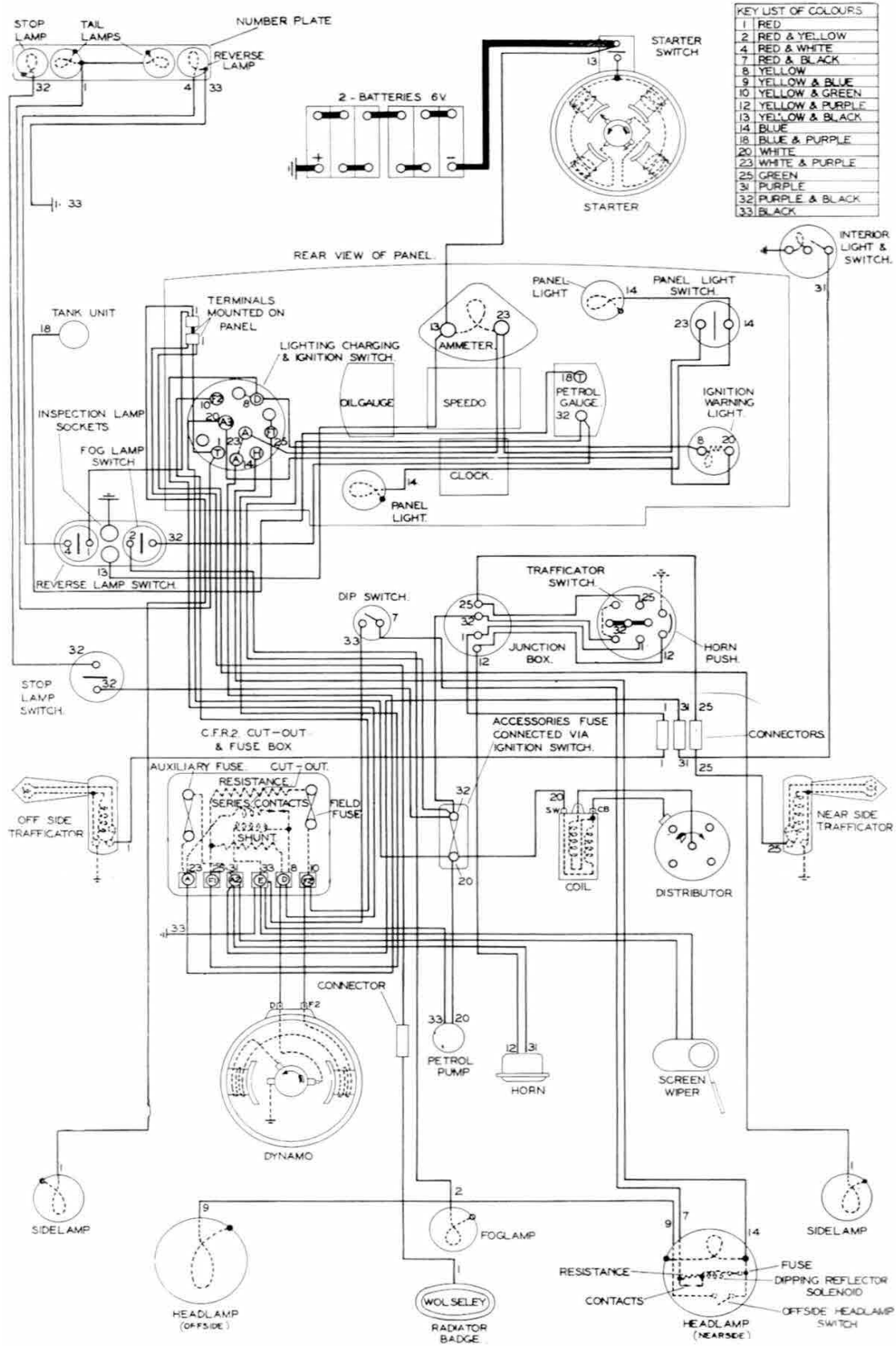

## HOW TO LOCATE AND REMEDY DYNAMO TROUBLE

SYMPTOMS	POSSIBLE CAUSES	REMEDY
Battery in low state of charge, shown by lack of power when starting. (Hydrometer readings less than 1.200.)	Dynamo not charging, indicated by ammeter not showing charge reading.	
	Broken or loose connection in dynamo circuit, or field fuse blown.	Examine charging and field circuits wiring. Tighten loose connection or replace blown fuse. Particularly examine battery connections. Return to Lucas Service Depot for attention. (See e 87.)
	Commutator greasy or dirty.	Clean with soft rag moistened with petrol. (See page 80.)
	Dynamo giving low or intermittent output, indicated by ammeter giving low or intermittent reading when car is running steadily in top gear. Due to	
	Brushes worn, not fitted correctly, or wrong type.	Replace worn brushes. See that brushes "bed" correctly. Fit correct type brushes. (See page 80.)
Battery overcharged, shown by very frequent need for "topping-up."	Dynamo giving high output, indicated by ammeter giving high charge reading. Due to :-	
	Incorrect setting of brushes.	Set third (control) brush to give lower output.

if, after following the above table, the trouble is not rectified, have the Dynamo, regulator and battery examined by a Lucas Service Depot.

## HOW TO LOCATE AND REMEDY LIGHTING TROUBLE

SYMPTOMS	PROBABLE FAULT	REMEDY
Lamps give insufficient illumination.	Battery discharged. (See page 84.)	Charge battery either by a long period of daytime running of from independent electrical supply.
	Bulbs out of focus.	Focus bulbs. (See page 90.)
	Bulbs discoloured through use, or reflectors dirty.	Fit new bulbs (see page 91) or clean reflectors. (See page 92.)
Lamps light when switched on, but gradually fade out,	Battery discharged.	Charge battery either by a long period of daytime running or from independent electrical supply.
Brilliance varies With speed of car.	Battery discharged.	Charge battery either by a long period of daytime running of from independent electrical supply.
	Battery connections loose or broken,	Tighten connections or replace faulty cables
Lights flicker.	Loose connection.	Locate loose connection and tighten.
Failure of lights.	Battery discharged.	Charge battery either by a long period of daytime running of from independent electrical supply.
	Loose or broken connection,	Locate and tighten loose connection, or remake broken connection.
	Faulty bulbs.	Fit new bulbs. (See page 91.)



## HOW TO LOCATE AND REMEDY STARTER MOTOR TROUBLE

CONDITION	POSSIBLE CAUSES	REMEDY
Starter motor lacks power or fails to turn engine,	Stiff engine, indicated by inability to turn by hand.	Locate and remedy cause of stiffness,
	If engine can be turned by hand, then trouble may be due to :-	
	Battery discharged. (See page 84.)	Start by hand. Charge battery either by a long period of day-time running or from independent electrical supply. (See also page 85.)
	Broken or loose connection in starter circuit,	See that connections to battery, starter and starter switch are tight, and that cables connecting these units are not damaged.
	Starter commutator or brushes dirty.	Clean. (See page 82.)
	Brushes worn, not fitted correctly, or wrong type.	Replace worn brushes. See that brushes "bed" correctly. (See page 82.)
	Starter pinion jammed in mesh with flywheel.	Remove cap on end of shaft and rotate squared end of starter shaft with spanner. (See page 82.)
Starter operates, but does not crank engine,	Pinion of starter drive does not engage with flywheel.	Remove starter and clean sleeve with Paraffin. Do not grease it again after cleaning.
Starter pinion will not disengage from flywheel when engine is running.	Starter pinion jammed in mesh with flywheel.	Remove cap on end of shaft and rotate squared end of starter shaft with spanner. (See page 82.)

## LUCAS SERVICE DEPOTS

In the event of any difficulty with any part of the equipment, no matter how trivial, we shall be only too pleased to give every assistance possible. The best course to adopt is to call at the nearest Lucas Service Depot, the addresses of which are given below, when the equipment can be examined as a whole. The depots are not only at your disposal for repairs, overhauls and adjustments, but to give free advice. If it is necessary, however, to communicate, or when ordering spare parts, always give the type and number of the unit in question, the make and, if possible, the date of the car on which it is fitted.

BELFAST 3-5 Calvin St., Mount Pottinger.	<i>Telegrams</i> : " Servdep, Belfast " <i>Telephone</i> : Belfast 57291 (3 lines)
BIRMINGHAM, 18 Great Hampton Street.	<i>Telegrams</i> : " Lucas, Birmingham " <i>Telephone</i> : Central 8401 (10 lines)
BRIGHTON, 4 85 Old Shoreham Road, Hove.	<i>Telegrams</i> : " Luserv, Brighton " <i>Telephone</i> : Hove 1146/49
BRISTOL 345 Bath Road.	<i>Telegrams</i> : " Kingly, Bristol " <i>Telephone</i> : Bristol 76001 (4 lines)
CARDIFF 54a Penarth Road.	<i>Telegrams</i> : " Lucas, Cardiff " <i>Telephone</i> : Cardiff 4603 (4 lines)
COVENTRY Priory Street.	<i>Telegrams</i> : " Lucas, Coventry " <i>Telephone</i> : Coventry 3068
DUBLIN Portland Street North, North Circular Road.	<i>Telegrams</i> : " Luserv, Dublin " <i>Telephone</i> : Drumcondra 434 (4 lines)
EDINBURGH, 11 60 Stevenson Road, Gorgie.	<i>Telegrams</i> : " Luserv, Edinburgh " <i>Telephone</i> : Edinburgh 62921 (4 lines)
GLASGOW Corner of Grant Street and St. George's Road.	<i>Telegrams</i> : " Lucas, Glasgow " <i>Telephone</i> : Douglas 3075 (5 lines)
LEEDS 64 Roseville Road.	<i>Telegrams</i> : " Luserdep, Leeds " <i>Telephone</i> : Leeds 28591 (5 lines)
LIVERPOOL, 13 450-456 Edge Lane.	<i>Telegrams</i> : " Luserv, Liverpool " <i>Telephone</i> : Old Swan 1408 (5 lines)
LONDON Dordrecht Road, Acton Vale, W.3.	<i>Telegrams</i> : " Dynomagna, Ealux, London " <i>Telephone</i> : Shepherd's Bush 3160 (10 lines)
LONDON 155 Merton Road, Wandsworth, S.W.18.	<i>Telegrams</i> : " Luserv, Put, London " <i>Telephone</i> : Putney 5131 (4 lines)
LONDON 757-759 High Road, Leyton, E.10.	<i>Telegrams</i> : " Luserdep, Leystone, London " <i>Telephone</i> : Leytonstone 3361 (5 lines)
MANCHESTER Talbot Road, Stretford.	<i>Telegrams</i> : " Lucas, Stretford " <i>Telephone</i> : Longford 1101 (5 lines)
NEWCASTLE-ON-TYNE, 2 64-68 St. Mary's Place.	<i>Telegrams</i> : " Motolite, Newcastle-on- Tyne " <i>Telephone</i> : Central 25571 (3 lines)

In addition there are Official Battery Service Agents, Official Spares Stockists and Official Spares Dealers in all parts of the country.

## **Decarbonising and Valve Grinding**

THE existence of an excessive carbon deposit within the cylinder head is usually indicated by a falling off in power accompanied by a metallic noise from the engine when it is pulling hard uphill or picking up on top gear. This metallic noise is commonly known as " pinking," and is somewhat similar to that produced when the ignition is too far advanced, although it must not be confused with this noise.

Decarbonising and grinding-in of the valves of the Wolseley 10/40 and 12/48 engines is in reality a very simple operation well within the capacity of the average " handy-man." The materials required, in addition to the standard tool kit, are a plentiful supply of clean rags, some valve grinding paste, a special suction type valve grinding tool, a flat tin (a deep baking tin is particularly suitable), and some paraffin to make a washing bath. A proper valve spring compressing tool and valve rocker tool are advisable for the operation of valve removal. These special tools can be obtained from the Service Dept., or from your local Wolseley Dealer.

Having collected the required equipment, start up the engine and let it run until it is nicely warm. It is far more comfortable to work on a warm engine. Then manoeuvre the car so that the radiator is near a drain or other suitable place where the cooling water can be run off. While the radiator is draining, you may with advantage proceed to remove the bonnet by unscrewing the two bolts which attach the stays to the radiator and tilt the radiator slightly forward so that the bonnet hinge rod clears the socket in the radiator. For safety disconnect the positive battery lead from the batteries.

### **Removing the Cylinder Head**

Commencing operations on the right side of the engine, the carburettor air cleaner should be removed, after releasing the end of the air intake pipe from the carburettor and disconnecting the fume pipe hose. Disconnect the petrol pipe from the carburetor together with the carburettor mixture control wire and also release the control wire casing from its support. Now disconnect the throttle control rod and the slow-running control wire. Unscrew the oil gauge pipe union and the nut which will enable you to release the oil feed pipe from the cylinder head.

Next uncouple the exhaust pipe from the outlet of the exhaust manifold by removing the three flange nuts and detach the small manifold drain pipe flange from the manifold.

Between the exhaust and inlet manifold branches will be found a series of eight extended hexagon nuts. These nuts should be removed. This will permit the inlet and exhaust manifold to be withdrawn from the cylinder block.

Next uncouple the high-tension wires from the sparking plugs, marking them to facilitate correct reassembly.

It is now necessary to release and disconnect the water hose connections between the cylinder head and the radiator header tank, between the two rear portions of the water by-pass pipe and that at the rear of the cylinder head and remove the fan belt by completely removing the dynamo adjustment bolt.

The cylinder head is attached to the cylinder block by eleven nuts screwed on to studs passing right through the cylinder head, and in order to gain access to those marked "5" and "k" on the illustration on page 106 it is necessary to withdraw the tappet rods. For this purpose the special tool is required to raise the rockers clear of the upper ends of the tappet rods.

In the case of the 12;48 engine it is necessary to remove the tappet cover on the side of the engine, and this entails removal of the dynamo and its cradle.

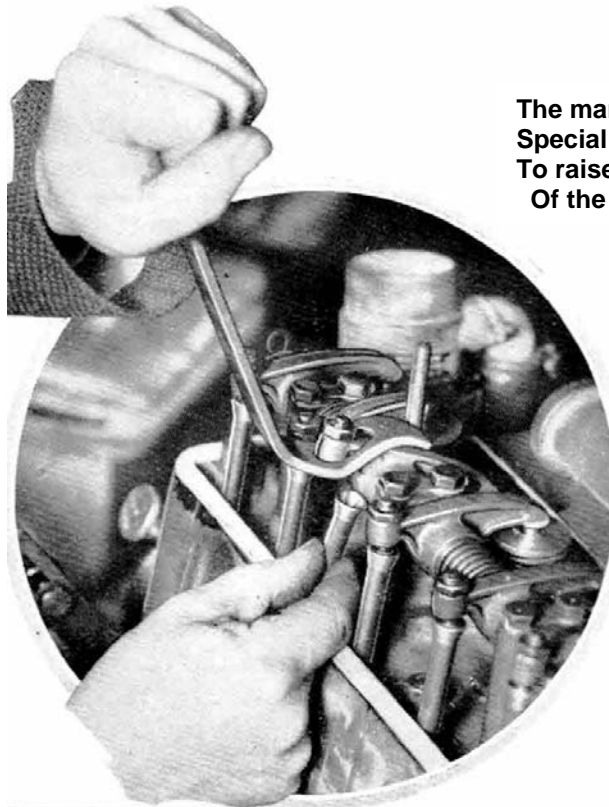

The manner in which the Special rocker tool is used To raise the rockers clear Of the tappet rods

These nuts should be slackened off in the rotation shown in the illustration on page 106—half a turn at a time until they are quite loose, and eventually entirely removed. It is unwise to unscrew any one of these nuts completely before slackening off the remainder, as this is liable to impose uneven stress upon the cylinder head, leading to its distortion. *When the cylinder head cover is removed, great care should be taken to see that nuts, etc., are not permitted to fall into the push-rod ducts. Any articles dropped into these ducts will find their way into the crankcase, necessitating removal of the engine sump before they can be retrieved.*

The breaking of the joint between the head and the cylinder block will be facilitated by smartly tapping each side of the head with a wooden mallet, or hammer with a piece of wood interposed to take the blow, or by rotating the engine a few times by the use of the self-starter with the ignition switched off, having temporarily replaced the battery positive lead.

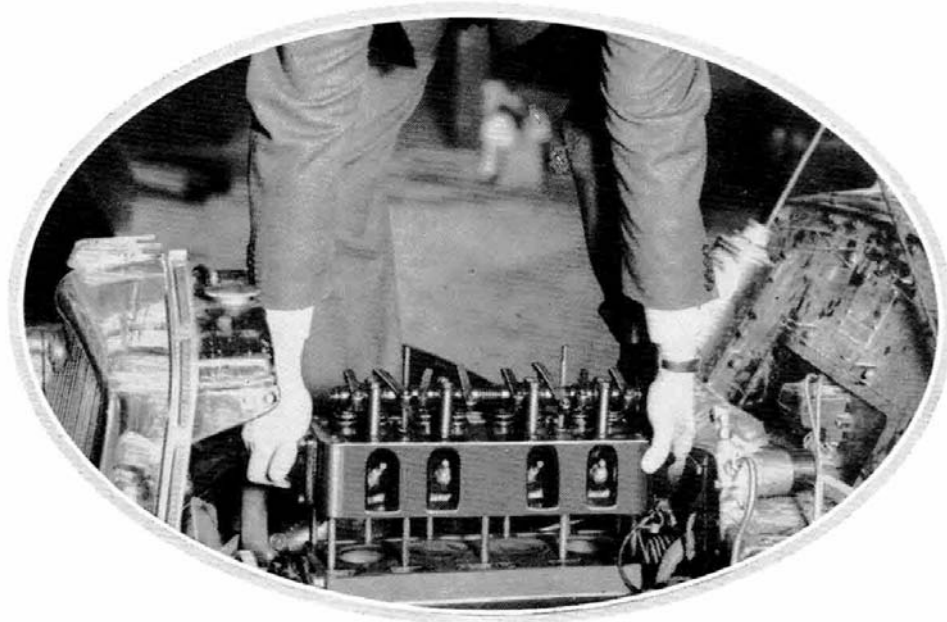

**Withdrawing the cylinder head.**

When lifting the cylinder head a direct upward pull should be given so that it is withdrawn squarely off the studs, and this is best achieved by standing with one foot on the front engine bearer and the other on the steel dash. A certain amount of water remains trapped in the base of the head, and care should be taken while withdrawing it not to spill some of this water into the engine.

Having withdrawn the head, place it on a bench out of harm's way, and carefully lift the copper-asbestos gasket straight off the cylinder head studs, keeping it parallel with the upper face of the cylinder block and taking particular care that it is not bent or otherwise damaged in the process.

### **Decarbonising**

Turn the engine by the starting handle until any two pistons are at the top of their travel. 'Stuff the open ends of the other cylinder mouths with clean rag, not forgetting the push-rod and water ducts at the sides of the cylinder block. With an old screwdriver, or similar blunt instrument, scrape the black deposit off the tops of the pistons, leaving a rim of carbon 1/2 in. wide undisturbed round the outside edge of the piston and leaving also the small rim of carbon deposit at the upper end of the cylinder bore undisturbed. Scrape away the

carbon from the cylinder block around the bores. With a clean rag dampened with paraffin, clean off every trace of foreign matter remaining, but do not attempt to polish things up with emery cloth or similar abrasive material or you will do far more harm than good. When these two pistons have been properly cleaned, give the starting handle a half turn until the two remaining pistons reach the top of their stroke, and deal with these two in the same way.

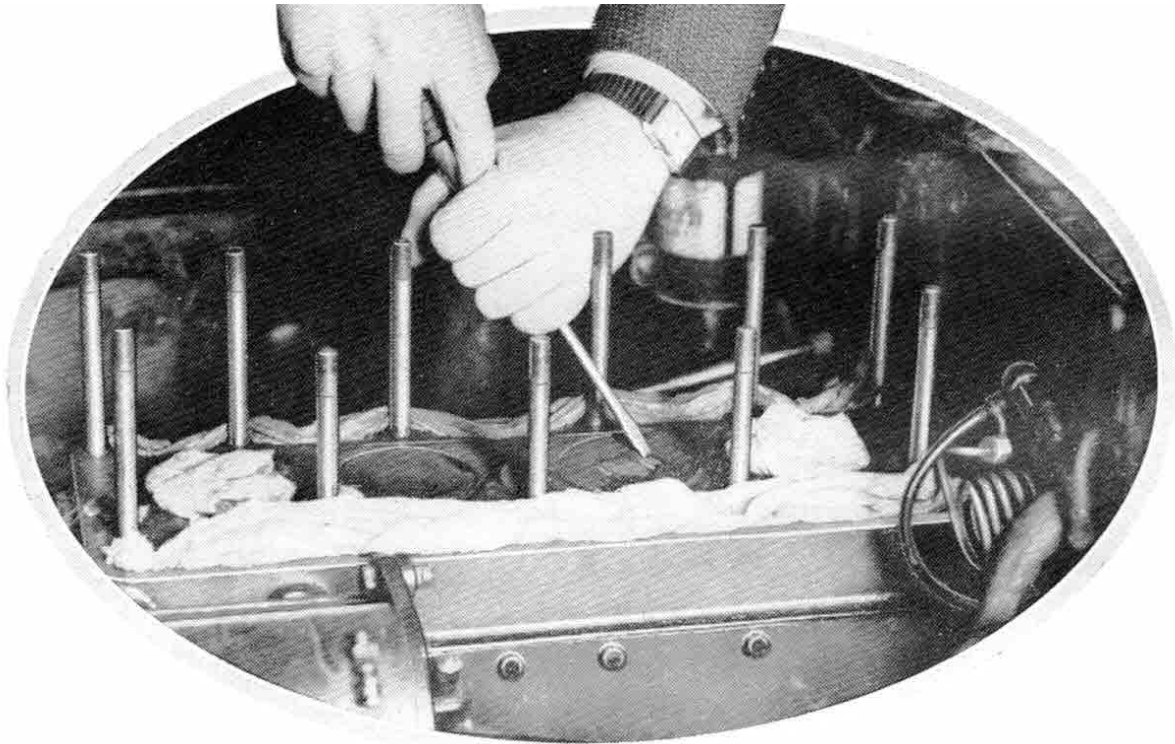

Scraping the carbon from the piston crowns.

### **Decarbonising the Cylinder Head**

Having completed the operations on the cylinder block, attention may now be given to the cylinder head. Remove the plugs and turn the head upside-down, thus exposing the combustion chambers. The carbon deposit adhering to the surfaces of these combustion spaces, the valve heads and the plug holes should be scraped away with a blunt screwdriver as before, and their surfaces carefully cleaned with a rag moistened with paraffin. The flat surface of the underside of the head should also be carefully cleaned, and all trace of jointing compound removed. Both surfaces of the copper-asbestos gasket should also be cleaned in a similar manner.

The valves may with advantage be removed for grinding, as by the time the Decarbonising operation becomes necessary these also are in need of a certain amount of attention, and while the head is removed this entails very little extra work.

## Removing the Valves

In order to release the valve it is necessary to remove the split cone cotters from the groove in the valve stem, and this is achieved with the help of a spring compressing tool, No. 75179 (obtainable from any Wolseley Dealer or the Works at 6/6, postage extra), which enables one to compress the spring until the cap is clear of the cotters, which can then readily be withdrawn from their retaining groove. When removing the cotters care should be exercised to see that they are not lost. When

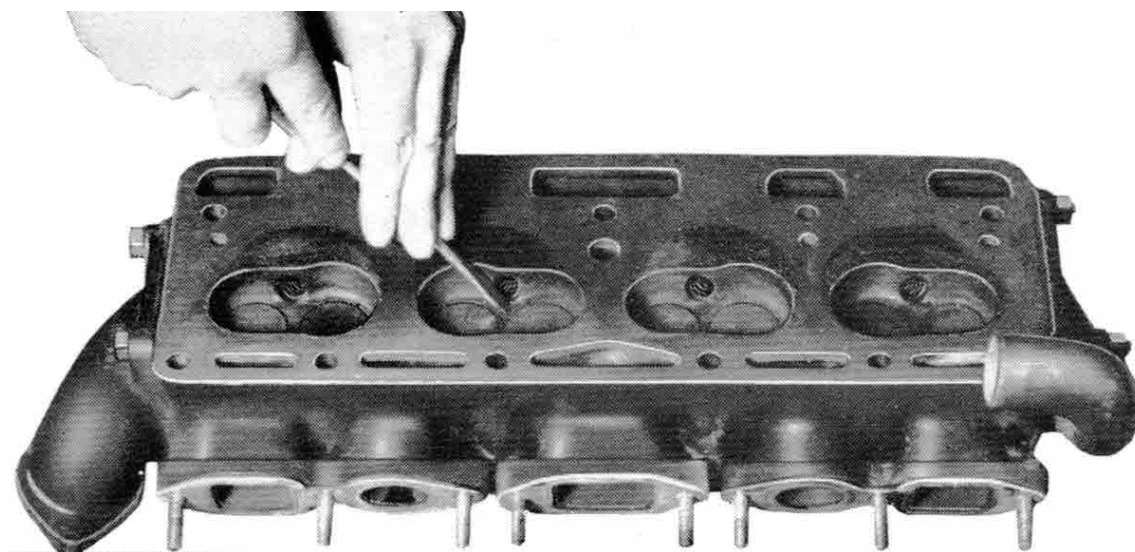

**Decarbonising the cylinder head of the Wolseley 12/48.**

the valve spring has been released by removal of the cotters, the valve may be withdrawn from its guide and the stem thoroughly cleaned in readiness for the valve-grinding process.

## Grinding-in the Valves

When grinding-in the valves the utmost care should be taken to see that they are inserted into the correct port. Each valve is clearly numbered on its head in sequence, No. 1 valve being at the forward end of the engine.

The grinding-in process consists in coating the bevelled face of the valve with a small quantity of valve-grinding paste applied on the end of a matchstick, reinserting the valve in its guide and partially rotating it backwards and forwards on its seating by means of the special suction valve grinding tool. Here we come to the secret of good valve grinding. The valve should be raised from its seating every few reciprocations and given half a turn in order that the grinding compound may spread itself evenly over the whole surface. The most

convenient way of carrying out this periodical lifting is to obtain a light coil spring (similar to the valve spring but very much lighter), and insert it into the valve port beneath the valve head. When pressure is released on the grinding tool the valve will pop up, and it can easily be rotated into a fresh position.

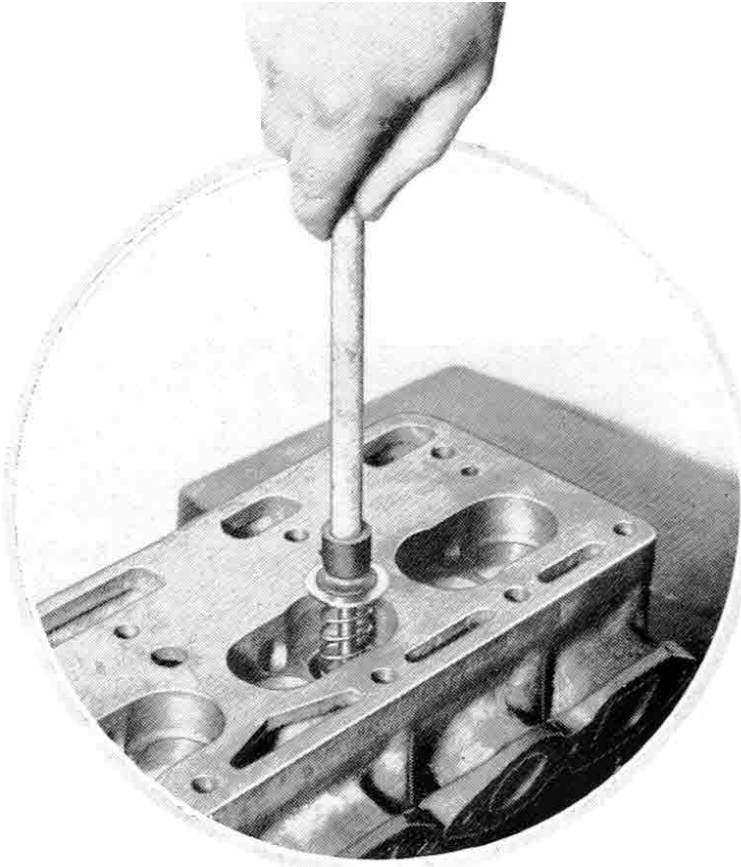

**The insertion of a light spring under the valve head greatly facilitates valve grinding.**

It is not necessary to continue grinding the valves once the faces of both valve and seating have assumed a clean, even matt-surfaced appearance. A polished surface must not be expected and is indeed quite unnecessary. If the engine has been run for a long period without being decarbonised, the valve face may be badly "pitted"—that is to say, it will have a number of small black spots or depressions on its face. It is then best to have the valve face trued up on a special machine at a garage. This will prevent needless grinding away of the valve seating in the cylinder block—a matter of importance, as it cannot be renewed easily. Any valves which are distorted should immediately be replaced by new ones. To attempt to grind them in would only produce extensive damage to the seating. After each valve is ground in, it should be withdrawn and carefully washed with paraffin, and, what is equally important, the valve seating and the surrounding valve port should also thoroughly be cleaned with a



rag moistened with paraffin. Do not wash out the valve ports with petrol or paraffin or some of the grinding compound will find its way into the valve guides or other working parts.

### **Reassembly of the Valves**

The valves may then be reassembled. Care should again be taken to see that they are in their correct ports. Reassembly of the valves

**Grinding - in the valves with the help of the special suction tool**

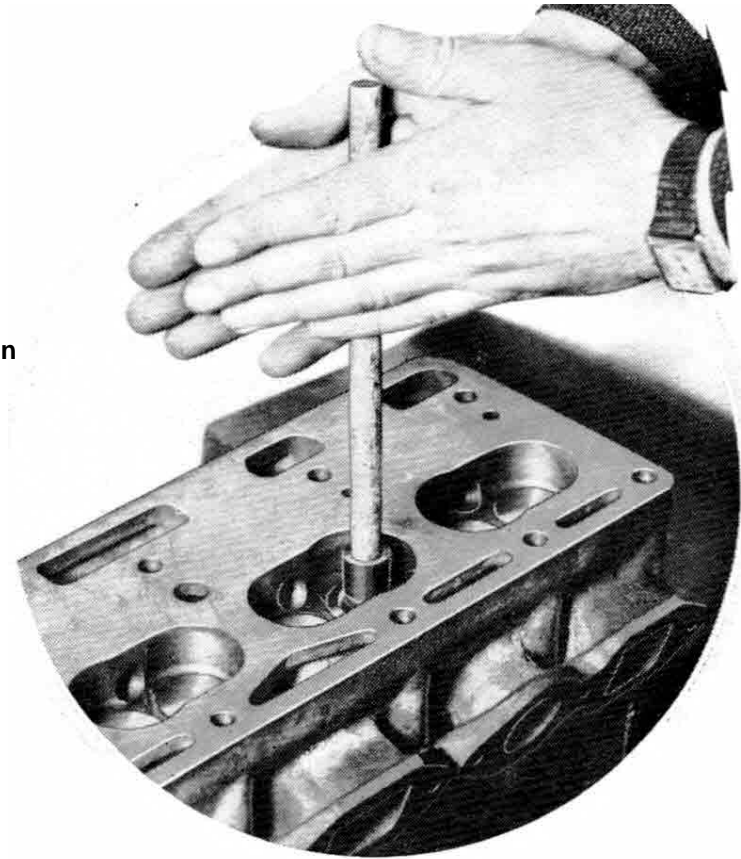

is not a difficult matter with the help of the standard valve spring tool. After inserting the valve in its guide and passing it through the hole in the spring cap, the valve spring tool may be placed in position and the spring compressed until the cotter groove is clear of the spring cap. This will enable the cotters to be inserted easily, and release of the pressure on the valve spring will cause the valve spring cap to embrace them and firmly lock them in position.

Control of the cotters will be facilitated by smearing them with thick grease, which will enable them to remain in position in the valve stem groove while the spring cap is released.

### **Replacing the Cylinder Head**

First of all, it is necessary to clean carefully both sides of the gasket. If the gasket has been in any way damaged during its removal, do not attempt to use it again but immediately procure a new one. See

that the new gasket is perfectly flat and does not burr up around the stud holes. The cylinder head gasket, when coated, can be located over the cylinder head studs and gently pushed into position on to the upper face of the cylinder block. It may be found convenient to use a short length of tubing (a box spanner does very well) over the studs in order to push the gasket into position. This should be done very gently, taking great care to keep the gasket parallel with the cylinder head and not to force one end or one side down before the other.

Removal of the cylinder head and valve grinding in no way affects engine timing, and no special precautions in this direction are necessary.

With the gasket safely in position, the cylinder head may be lowered into position on to the cylinder block and the cylinder head stud nuts replaced.

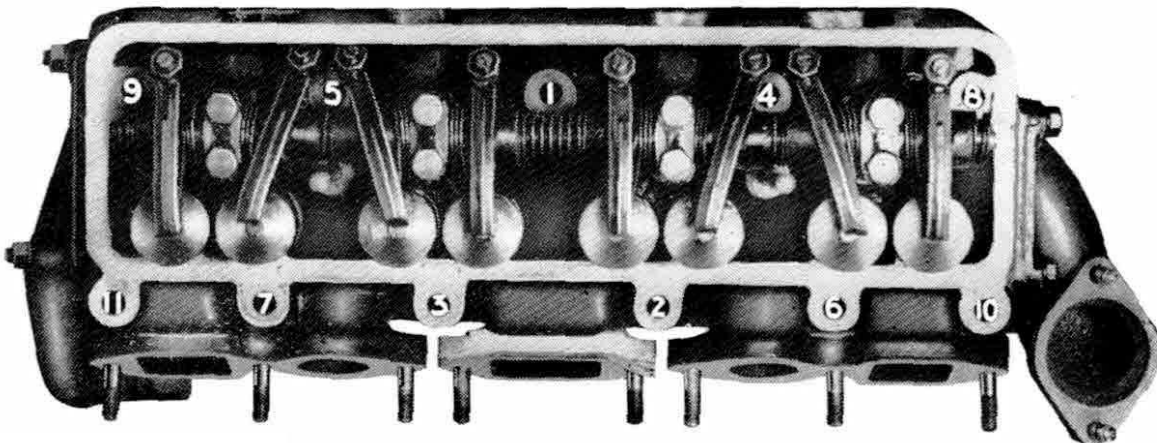

**The correct order of tightening the cylinder head stud nuts.**

Care must again be taken when tightening these cylinder head studs to do so in rotation a quarter of a turn at a time, until all are quite tight, preferably in the sequence indicated in the accompanying illustration. The water outlet pipe, water by-pass hose and cylinder head water connection can now be replaced, followed by the exhaust and inlet manifold, plugs, plug leads, carburettor, tappet rods, petrol pipe, air cleaner and carburetor, throttle and mixture controls, tappet cover, dynamo, driving belt, the oil pipe lead to the cylinder head and to the oil gauge, and the manifold drain pipe.

Fill the radiator with water, start up the engine, and let it idle quietly until it is thoroughly warm. Then, switching off again, go over each of the cylinder head nuts in turn, giving each a final tightening up. It will be found that now the engine is warm an extra half turn or so can be given to each nut. Do not attempt to speed up the engine until this final tightening has been effected.

When the cylinder head cover and the bonnet are replaced the car is ready for the road.

After 250 miles the cylinder head nuts should be given yet another tightening up. The valve cover should be removed after this mileage and both these nuts tightened up and the valve clearances checked, as a certain amount of bedding-down takes place after the grinding process. Remember that it is always necessary to check over the valve clearance after tightening the cylinder head stud nuts, as this may cause a slight variation to the setting.

## General Data

### WOLSELEY 10/40 H.P. AND 12/48 H.P.

	<i>Wolseley 10/40 h.p.</i>	<i>Wolseley 12/48 h.p.</i>
Number of cylinders	Four	Four
Bore .....	2.5 in. (63.5 mm.)	2.73 in. (69.5 mm.)
Stroke.....	4.01 in. (102 mm.)	4.01 in. (102 mm.)
Cubic capacity .....	78.84 Cu. in (1292 c.c.)	94.39 Cu. in. (1550 c.c)
R.A.C. rating.....	10	11.98
Tax.....	£7 10s.	£9
Number of gears.....	Four and reverse	Four and reverse
Gears ratios		
First.....	20.88	20.88
Second.....	12.334	12.334
Synchromesh Third.....	7.987	7.987
Fourth .....	5.22	5.22
Reverse...	26.88	26.88
Turning circle.....	R.H. 40 ft. . L.H. 38 ft. 6 in.	R.H. 40 ft. . L.H. 38 ft. 6 in.
Tyre size.....	3.50 by 16	3.50 by 16
Wheelbase.....	5.75-16	5.75-16
Wheel size.....	8 ft. 4 in. (2.54 m.)	8 ft. 4 in. (2.54 m.)
Track.....	4 ft. 2 in. (1.27 m.)	4 ft. 2 in. (1.27 m.)
Petrol tank capacity.....	7 gallons (32 litres)	7 gallons (32 litres)
Engine oil capacity.....	11 gallons (6.25 litres)	18 gallons (6.25 litres)
Gearbox oil capacity.....	2 pints (1.14 litres)	2 pints (1.14 litres)
Rear axle oil capacity.....	3 pints (1.7 litres)	3 pints (1.7 litres)
Total water capacity.....	18 pints (10.22 litres)	18 pints (10.22 litres)

# ~ ~ ~ ~ ~ INDEX ~ ~ ~ ~ ~

	Page		Page
Access to Brake-shoes ... ..	48	Care of Coachwork	15
Accelerator ... ..	6	Care of Cooling System	16
Additional Electric Accessories	-	Care of New Engine	15
Wiring ... ..	86	Care of Radiator	16
Adjusting Contact Breaker ... ..	77	Care of Springs	17
Adjusting the Driving Position ... ..	5	Care of Tyre Pressures	17
Adjustments ... ..	19	Care of Tyres	64
Adjustments, Carburettor ... ..	34	Care of Upholstery	16
Adjustments, Clutch Pedal ... ..	24	Care of Wings	15
Adjustments, Coachwork ... ..	28	Changing Dipping Reflectors for Right-	-
Adjustments, Dynamo ... ..	23	hand Rule of the Road	91
Adjustments, Hand Brake ... ..	51	Changing Gear	11
Adjustments, Hydraulic Brake ... ..	46	Charging Switch, Use of the	85
Adjustments, Tappet ... ..	19	Chart, Oiling	113
Adjustments, Windscreen ... ..	19	Chassis Lubrication	60
Air Cleaner, Silencer and Fume	-	Chassis Lubrication Oilgun	60
Consumer ... ..	29	Chromium Finish, Care of	17
Aligning Headlamps ... ..	90	Cleaning the Distributor	77
Ammeter ... ..	9	Cleaning Lamp Reflectors	92
Ammeter Readings ... ..	81	Clutch	24
Attention to Batteries ... ..	83	Clutch Control	6
Attention to Hydraulic jacks ... ..	31	Clutch Lubrication	56
Attention to Starter ... ..	82	Clutch Pedal Adjustments	24
Attention, Summary of Lubrication ... ..	63	Coachwork Adjustments	28
Attention, Summary of Routine ... ..	63	Coachwork, Care of	15
Automatic Controls ... ..	6	Coil, Ignition	78
Automatic Ignition Control ... ..	76	Coil Ignition System	76
Axle, Rear ... ..	27	Cold Weather, Starting in	82
-	-	Commutator, Dynamo	80
-	-	Connecting Links, Shock Absorber	69
Banging in Silencer ... ..	73	Connecting Rods	22
Batteries, Attention to ... ..	83	Contact Breaker, Adjusting	77
Batteries, Keeping Charged ... ..	85	Control, Automatic Ignition	76
Bleeding the Hydraulic Brakes ... ..	50	Control, Brake	6
Bodywork Lubrication ... ..	62	Control, Clutch	6
Brake Adjustments, Hydraulic ... ..	46	Control, Dipping Headlamp	6
Brake Control ... ..	6	Control, Mixture	5
Brake Fluid, Hydraulic ... ..	50	Control, Slow-running	5
Brake Fluid, Leakage of ... ..	51	Control, Thermostatic Water	6
Brake Gear Lubrication ... ..	62	Control, Throttle	5
Brake, Hand ... ..	51	Controls	4-5
Brake Linings ... ..	48	Controls, Automatic	6
Brake Master Cylinder, Hydraulic ... ..	45	Controls, Hand	5
Brake Pipe Line, Hydraulic ... ..	46	Cooling System, Care of	16
Brake Replenishments, Hydraulic ... ..	46	Correcting Ignition Faults	79
Brake Supply Tank, Hydraulic ... ..	45	Crankshaft	21
Brake Wheel Cylinders, Hydraulic ... ..	45	Cut-out	81&87
Brake-shoes, Access to ... ..	48	Cylinder Head, Decarbonising	102
Brakes, Bleeding the Hydraulic ... ..	50	Cylinder Head, Removing the	99
Brakes, Hydraulic ... ..	45	Cylinder Head, Replacing the	105
Brakes, Important points concerning	51	-	-
Brush Gear, Dynamo ... ..	80	-	-
Bulbs, Replacement ... ..	91	Data, General	108
Bulbs, Spare ... ..	91	Dead Centre, 'Pop	13
Bulbs, Trafficator ... ..	93	Decarbonising	101
-	-	Decarbonising Cylinder Head	102
-	-	Decarbonising and Valve Grinding	99
Cable, Renewing High-tension ... ..	78	Descending Steep Hills	13
Camshaft ... ..	21	Diagram, Wiring	94
Capacities, Engine Oil ... ..	54	Dipping Headlamp Control	6
Capacity, Gearbox ... ..	59	Dipping Headlamp Reflectors	91
Car, Stopping the ... ..	12	Dipping Reflectors, Changing for	-
Carburettor ... ..	33	Right-hand Rule of the Road ... ..	91
Carburettor Adjustments ... ..	34	Distributor, Cleaning the	77
Carburettor Float-chamber Flooding ... ..	37	Distributor Lubrication	61&87
Carburettor Filter ... ..	39	Draining the Engine Sump	56
Carburettor Piston Sticking ... ..	35	Draining the Gearbox	59
Carburettor Trouble, Sources of ... ..	35	Driving Position	5
Carburettor, Water or Dirt in ... ..	37	Driving Position, Adjusting	5
Care of Car, General ... ..	17	Dynamo Adjustments	23
Care of Chromium Finish ... ..	15	Dynamo Brush Gear ... ..	80

~~~~~**INDEX (contd.)**~~~~~

|                                           | <i>Page</i> |                                    | <i>Page</i> |
|-------------------------------------------|-------------|------------------------------------|-------------|
| Dynamo Commutator ... ..                  | 80          | Hand Controls                      | 5           |
| Dynamo Lubrication ... ..                 | 80          | Headlamp Control, Dipping          | 6           |
| Dynamo Output ... ..                      | 81          | Headlamp Front, Removing           | 89          |
| Dynamo Switch ... ..                      | 7           | Headlamp Reflectors Dipping        | 91          |
| Dynamo Trouble Location ... ..            | 95          | Headlamp Reflector, Removing       | 89          |
|                                           |             | Headlamp Reflector Fuse            | 87          |
| Electric horn ... ..                      | 92          | Headlamps, Aligning                | 90          |
| Electrical Accessories, Wiring Additional | 86          | Headlamps, Focussing               | 90          |
| Electrical Petrol Pump ... ..             | 41          | High-tension Cable, Renewing       | 73          |
| Electrical Wiring ... ..                  | 86          | Horn, Electric                     | 92          |
| Engaging Gear ... ..                      | 11          | Horn Push                          | 9           |
| Engine, New, Care of                      | 15          | Hydraulic Brake Adjustments        | 46          |
| Engine Knocks when Pulling Hard           | 74          | Hydraulic Brake Fluid ..           | 50          |
| Engine Lacks Power ... ..                 | 73          | Hydraulic Brake Master Cylinder    | 45          |
| Engine Lubrication ... ..                 | 54          | Hydraulic Brake Pipe Line          | 46          |
| Engine Misses at All Speeds               | 71          | Hydraulic Brake Supply Tank        | 45          |
| Engine Misses at High Speeds only         | 71          | Hydraulic Brake Replenishments     | 46          |
| Engine Misses at Low Speeds only          | 72          | Hydraulic Brake Wheel Cylinders    | 45          |
| Engine Oil Capacities ... ..              | 54          | Hydraulic Brakes                   | 45          |
| Engine Oil Pressures ... ..               | 55          | Hydraulic Brakes, Bleeding the     | 50          |
| Engine Runs Hot ... ..                    | 74          | Hydraulic Jack Fluid               | 32          |
| Engine Spits through Carburetter          | 72          | Hydraulic Jack Fluid Container     | 31          |
| Engine Stops Suddenly ... ..              | 72          | Hydraulic Jack System, Refilling   | 32          |
| Engine Sump, Draining the ... ..          | 56          | Hydraulic Jacks, Attention to      | 31          |
| Engine Will not Start ... ..              | 71          | Hydraulic Jacks, Jackall           | 30          |
| External Oil Filter Replacement           | -           | Hydraulic Shock Absorbers          | 69          |
| Elements ... ..                           | 58          |                                    | -           |
| External Oil Filter, Tecalemit            | 57          |                                    | -           |
|                                           |             | Ignition Auxiliary Fusebox         | 88          |
| Fan ... ..                                | 22          | Ignition Coil                      | 78          |
| Fan Lubrication ... ..                    | 61          | Ignition Control, Automatic        | 76          |
| Faults, Correcting Ignition ... ..        | 79          | Ignition Faults                    | 75          |
| Faults, Ignition ... ..                   | 75          | Ignition Faults, Correcting        | 79          |
| Faults, Locating Ignition ... ..          | 79          | Ignition Faults, Locating          | 79          |
| Filling up with Oil ... ..                | 3           | Ignition Switch                    | 7&78        |
| Filling up with Petrol ... ..             | 3           | Ignition System, Coil              | 76          |
| Filling up with Water ... ..              | 4           | Ignition Warning Lamp              | 89          |
| Filter, Carburetter ... ..                | 39          | Ignition Warning Light             | 78          |
| Filter, Petrol Pump ... ..                | 42          | Impeller, Water                    | 22          |
| Filter Replacement Elements, External     | 58          | Important Points concerning Brakes | 51          |
| Float-chamber Flooding ... ..             | 37          | Inspection Lamp Sockets            | 7           |
| Fluid, Lockheed ... ..                    | 50          | Instruments                        | 9           |
| Focussing Headlamps ... ..                | 90          | Instrument Panel Lamps, Replacing  | 89          |
| Fog lamp Front and Reflector, Re-         |             | Instrument Panel Lamps Switch      | 8           |
| Moving ... ..                             | 89          |                                    | -           |
| Foglamp Switch ... ..                     | 7           |                                    | -           |
| Front Wheels ... ..                       | 27          | Jack, Refilling Hydraulic System   | 32          |
| Frosty Weather, Precautions in ... ..     | 16          | Jack Fluid, Hydraulic              | 32          |
| Fume Consumer, Air Cleaner, Silencer      | -           | Jack Fluid Container, Hydraulic    | 31          |
| And ... ..                                | 29          | Jacks, Attention to Hydraulic      | 31          |
| Fuse, Headlamp Reflector ... ..           | 87          | Jacks, Jackall Hydraulic           | 30          |
| Fuses ... ..                              | 86          | Jackall Hydraulic Jacks            | 30          |
| Fusebox... ..                             | 87          |                                    | -           |
| Fusebox, Ignition Auxiliary ... ..        | 88          | Keeping the Batteries Charged      | 85          |
|                                           |             |                                    | -           |
| Gauge, Oil ... ..                         | 9           | Lamp Fronts, Removing Stop, Tail   | -           |
| Gauge, Petrol ... ..                      | 9           | and Reverse                        | 89          |
| Gear, Changing ... ..                     | 11          | Lamp, Ignition Warning             | 89          |
| Gear, Engaging ... ..                     | 11          | Lamp Reflectors, Cleaning          | 92          |
| Gear Positions ... ..                     | 10          | Lamp Sockets, Inspection           | 7           |
| Gearbox, Capacity ... ..                  | 59          | Lamp Switch, Fog                   | 7           |
| Gearbox, Draining of ... ..               | 59          | Lamp Switch, Reverse               | 7           |
| Gearbox Lubrication ... ..                | 58          | Lamps, Replacing Instrument Panel  | 89          |
| General Care of Car ... ..                | 15          | Lamps Switch, Instrument Panel     | 8           |
| General Data ... ..                       | 108         | Leakage of Brake Fluid             | 51          |
| Grinding-in the Valves ... ..             | 103         | Lighting and Starting System       | 80          |
|                                           |             | Lighting Switch                    | 7           |
| Hand Brake ... ..                         | 51          | Lighting Trouble Location          | 96          |
| Hand Brake Adjustments ... ..             | 51          | Locating Ignition Faults           | 79          |

~~~~~ **INDEX (contd.)** ~~~~~

|                                       | <i>Page</i> |                                       | <i>Page</i> |
|---------------------------------------|-------------|---------------------------------------|-------------|
| Lockheed Fluid ... ..                 | 50          | Refilling Hydraulic Jack System ...   | 32          |
| Lubrication ... ..                    | 53          | Refitting, Tyre ... ..                | 65          |
| Lubrication, Bodywork ... ..          | 62          | Reflectors, Cleaning Lamp ... ..      | 92          |
| Lubrication, Brake Gear ... ..        | 62          | Reflectors, Dipping Headlamp          | 91          |
| Lubrication, Chassis ... ..           | 60          | Reflector, Removing Foglamp Front     |             |
| Lubrication, Clutch ... ..            | 56          | and... ..                             | 89          |
| Lubrication, Distributor ... ..       | 61&76       | Reflector, Removing Sidelamp Front    |             |
| Lubrication, Dynamo ... ..            | 80          | and... ..                             | 89          |
| Lubrication, Engine ... ..            | 54          | Reflector Fuse, Headlamp ... ..       | 87          |
| Lubrication, Fan ... ..               | 61          | Removal, Tyre ... ..                  | 65          |
| Lubrication, Gearbox ... ..           | 58          | Removing the Cylinder Head ... ..     | 99          |
| Lubrication, Rear Axle ... ..         | 59          | Removing Foglamp Front and Reflector  | 89          |
| Lubrication, Steering Connection ...  | 62          | Removing Headlamp Front ... ..        | 89          |
| Lubrication, Steering Gearbox ... ..  | 62          | Removing Headlamp Reflector ... ..    | 89          |
| Lubrication, Trafficator ... ..       | 93          | Removing Sidelamp Front and Reflector | 89          |
| Lubrication, Transmission ... ..      | 62          | Removing Stop, Tail and Reverse Lamp  |             |
| Lubrication, Universal Joint ... ..   | 62          | Fronts ... ..                         | 89          |
| Lubrication, Water Impeller... ..     | 61          | Removing the Valves ... ..            | 103         |
| Lubrication, Wheel Hub ... ..         | 59          | Renewing High-tension Cable ... ..    | 78          |
| Lubrication Attention, Summary of ... | 63          | Replacement Bulbs ... ..              | 91          |
| Lubrication Oilgun, Chassis... ..     | 60          | Replacing the Cylinder Head ... ..    | 105         |
| Lucas Service Depots ... ..           | 98          | Replacing Instrument Panel Lamps ...  | 89          |
|                                       |             | Replenishments, Shock Absorber ...    | 70          |
| Master Cylinder, Hydraulic Brake ...  | 45          | Reverse Lamp Switch ... ..            | 7           |
| Mixture Control... ..                 | 5           | Reverse Lamp Fronts, Removing         |             |
| Motor Misses at all Speeds ... ..     | 71          | Stop, Tail and... ..                  | 89          |
| Motor Misses at High Speeds only ...  | 71          | Rods, Connecting... ..                | 22          |
| Motor Misses at Low Speeds only ...   | 72          |                                       |             |
| Motor Runs Hot ... ..                 | 74          | Screen Wiper ... ..                   | 92          |
| Motor Will Not Start ... ..           | 71          | Service Depots, Lucas ... ..          | 98          |
|                                       |             | Shock Absorber Connecting Links ...   | 69          |
| Noisy Petrol Pump ... ..              | 43          | Shock Absorber Replenishments ...     | 70          |
|                                       |             | Shock Absorbers, Hydraulic ... ..     | 69          |
| Oil Capacities, Engine ... ..         | 54          | Sidelamp Front and Reflector, Re-     |             |
| Oil, Filling up with ... ..           | 3           | Moving ... ..                         | 89          |
| Oil Filter Replacement Elements ...   | 58          | Slow-running Control ... ..           | 5           |
| Oil Filter, Tecalemit External ... .. | 57          | Sources of Carburetter Trouble ...    | 35          |
| OilGauge ... ..                       | 9           | SpareBulbs ... ..                     | 91          |
| Oilgun, Chassis Lubrication... ..     | 60          | Sparkling Plug ... ..                 | 67          |
| Oil Pressures, Engine... ..           | 55          | Sparkling Plug Gap ... ..             | 67          |
| Oiling Chart ... ..                   | 113         | Speedometer ... ..                    | 9           |
| Oils, Recommended ... ..              | 53          | Springs, Care of... ..                | 17          |
| Output, Dynamo ... ..                 | 81          | Starter ... ..                        | 82          |
|                                       |             | Starter, Attention to ... ..          | 82          |
| Petrol, Filling up with ... ..        | 3           | Starter Motor does not Operate ...    | 73          |
| PetrolGauge ... ..                    | 9           | Starter Motor Trouble Location        | 97          |
| Petrol Pump, Electrical ... ..        | 41          | Starter Switch ... ..                 | 7           |
| Petrol Pump Fails to Deliver Petrol   | 43          | Starting in Cold Weather ... ..       | 82          |
| Petrol Pump Filter ... ..             | 42          | Starting and Lighting System... ..    | 80          |
| Petrol Pump, Noisy ... ..             | 43          | StartingUp ... ..                     | 10          |
| Petrol Pump Troubles, Tracing ... ..  | 41          | Steep Hills, Descending ... ..        | 13          |
| PetrolTap... ..                       | 9           | Steering Connection Lubrication ...   | 62          |
| Pipe Line, Hydraulic Brake ... ..     | 46          | Steering Gear ... ..                  | 26          |
| Pistons and Piston Rings ... ..       | 22          | Steering Gearbox Lubrication... ..    | 62          |
| Plug, Sparking ... ..                 | 67          | Stop, 'Fail and Reverse Lamp Fronts,  |             |
| Plug Gap, Sparking ... ..             | 67          | Removing... ..                        | 80          |
| Precautions in Frosty Weather ... ..  | 16          | Stopping the Car... ..                | 12          |
| Pressures, Care of Tyre ... ..        | 17          | Summary of Lubrication Attention ...  | 63          |
| Pressures, Engine Oil... ..           | 55          | Summary of Routine Attention... ..    | 63          |
| Pressures, Tyre... ..                 | 64          | Supply Tank, Hydraulic Brake... ..    | 45          |
|                                       |             | Switch, Dynamo ... ..                 | 7           |
| Radiator, Care of ... ..              | 16          | Switch, Fog Lamp... ..                | 7           |
| RearAxle ... ..                       | 27          | Switch, Ignition... ..                | 7&78        |
| Rear Axle Lubrication ... ..          | 59          | Switch, Instrument Panel Lamps ...    | 8           |
| Reassembling the Valves ... ..        | 105         | Switch, Lighting... ..                | 7           |
| Recommended Oils ... ..               | 53          | Switch, Reverse Lamp ... ..           | 7           |
|                                       |             | Switch, Starter ... ..                | 7           |
|                                       |             | Switch, Use of the Charging ... ..    | 85          |
|                                       |             | Switches ... ..                       | 7           |

~~~~~ **INDEX (contd.)** ~~~~~

|                                    | <i>Page</i> |                                     | <i>Page</i> |
|------------------------------------|-------------|-------------------------------------|-------------|
| Tail, Stop and Reverse Lamp Fronts |             | Valve Caps, Tyre                    | 66          |
| Removing ... ..                    | 89          | Valve Grinding and Decarbonising    | 99          |
| Tap, Petrol                        | 9           | Valve Interior, Tyre                | 66          |
| 'tappet Adjustments                | 19          | Valves, Grinding-in the             | 103         |
| Tappet Setting Table               | 21          | Valves, Reassembling the            | 105         |
| Tecalemit External Oil Filter      | 57          | Valves, Removing the                | 103         |
| Thermostatic Water Control         | 6           | Valves, Tyre                        | 66          |
| Throttle Control...                | 5           |                                     |             |
| Top Dead Centre                    | 13          | WarmingUp                           | 10          |
| Tracing Petrol Pump Troubles...    | 41          | Warning Lamp, Ignition...           | 89          |
| Tracing Troubles...                | 71          | Warning Light, The Ignition         | 78          |
| Trafficator Bulbs                  | 93          | Water Control, Thermostatic         | 6           |
| Trafficator Lubrication            | 93          | Water or Dirt in Carburetter...     | 37          |
| Trafficator Switch                 | 8           | Water, Filling up with...           | 4           |
| Trafficators                       | 93          | Water Impeller                      | 22          |
| Transmission Lubrication           | 92          | Water Impeller Lubrication          | 61          |
| Trouble Location, Dynamo           | 95          | Wheel Cylinders, Hydraulic Brake    | 45          |
| Trouble Location, Lighting         | 96          | Wheel Hub Lubrication               | 59          |
| Trouble Location. Starter Motor    | 97          | Wheels, Front                       | 27          |
| Troubles, Tracing...               | 71          | Windscreen Adjustments...           | 19          |
| Troubles, Tracing Petrol Pump      | 41          | Wings, Care of                      | 15          |
| Tyres, Care of                     | 64          | Wiper, Screen                       | 92          |
| Tyre Refitting                     | 65          | Wiring Additional Electrical Access |             |
| Tyre Pressures                     | 64          | ories                               | 86          |
| Tyre Pressures, Care of            | 17          | Wiring Diagram                      | 94          |
| Tyre Removal...                    | 65          | Wiring, Electrical                  | 86          |
| Tyre Valves                        | 66          |                                     |             |
| Tyre Valve Caps                    | 66          |                                     |             |
| 'Pyre Valve Interior               | 66          |                                     |             |
|                                    |             |                                     |             |
| Universal Joint Lubrication        | 62          |                                     |             |
| Upholstery, Care of                | 16          |                                     |             |
| Use of the Charging Switch         | 85          |                                     |             |