

# Rover 820, 825 & 827 Service and Repair Manual

---

J. S. Mead

---

Models covered

Rover 820, 825, 827 and Sterling models with 4-cylinder and V6 petrol engines,  
including special/limited editions  
1994 cc, 2494 cc & 2675 cc

*Does not cover 8-valve carburettor (petrol) engine or Diesel-engined models*

(1380-304-11AA3)

© Haynes Publishing 1997

A book in the Haynes Service and Repair Manual Series

All rights reserved. No part of this book may be reproduced or transmitted in any form or by any means, electronic or mechanical, including photocopying, recording or by any information storage or retrieval system, without permission in writing from the copyright holder.

ISBN 1 85960 273 8

British Library Cataloguing in Publication Data

A catalogue record for this book is available from the British Library.

ABCDE  
FGHIJ  
KLMNO  
PQRST  
1 2 3

Printed by J H Haynes & Co. Ltd, Sparkford, Nr Yeovil,  
Somerset BA22 7JJ

Haynes Publishing  
Sparkford, Nr Yeovil, Somerset BA22 7JJ, England

Haynes North America, Inc  
861 Lawrence Drive, Newbury Park, California 91320, USA

Editions Haynes S.A.  
147/149, rue Saint Honoré, 75001 Paris, France

Haynes Publishing Nordiska AB  
Box 1504, 751 45 Uppsala, Sweden

# Contents

---

## LIVING WITH YOUR ROVER

Introduction	Page	0•4
Safety First!	Page	0•5
General dimensions and weights	Page	0•6

## Roadside Repairs

Jacking, towing and wheel changing	Page	0•7
Jump starting	Page	0•9
Identifying leaks	Page	0•10

Radio/cassette unit anti-theft system – precaution	Page	0•10
--	------	------

Conversion Factors	Page	0•11
--------------------	------	------

## ROUTINE MAINTENANCE

### Routine maintenance and servicing

Routine maintenance	Page	1•1
Servicing Specifications	Page	1•2
Lubricants, fluids and capacities	Page	1•3
Maintenance schedule	Page	1•4
Maintenance procedures	Page	1•8
Weekly checks	Page	1•8
Every 6000 or six months	Page	1•11
Every 12 000 miles or 12 months	Page	1•13
Every 24 000 miles or 2 years	Page	1•23
Every 48 000 miles	Page	1•26
Every 60 000 miles or 5 years	Page	1•26

# Contents

---

## REPAIRS & OVERHAUL

### Engine and Associated Systems

4-cylinder engine – in-car engine repair procedures	Page	2A•1
V6 engine – in-car engine repair procedures	Page	2B•1
Engine removal and general engine overhaul procedures	Page	2C•1
Cooling, heating and air conditioning systems	Page	3•1
Fuel and exhaust systems – Single-point injection engines	Page	4A•1
Fuel and exhaust systems – Lucas multi-point injection engines	Page	4B•1
Fuel and exhaust systems – MEMS multi-point injection engines	Page	4C•1
Fuel and exhaust systems – Honda PGM-Fi injection engines	Page	4D•1
Fuel and exhaust systems – Emissions control systems	Page	4E•1
Engine electrical systems	Page	5•1

### Transmission

Clutch	Page	6•1
Manual transmission	Page	7A•1
Automatic transmission	Page	7B•1
Driveshafts	Page	8•1

### Brakes

Braking system	Page	9•1
----------------	------	-----

### Suspension and Steering

Suspension and steering systems	Page	10•1
---------------------------------	------	------

### Body Equipment

Bodywork and fittings	Page	11•1
Body electrical systems	Page	12•1

### Wiring Diagrams

Page 12•19

## REFERENCE

MOT Test Checks	Page	REF•1
General Repair Procedures	Page	REF•5
Tools and Working Facilities	Page	REF•6
Buying Spare Parts and Vehicle Identification Numbers	Page	REF•9
Fault Finding	Page	REF•10
Glossary of Technical Terms	Page	REF•18

### Index

Page REF•23

# Introduction to the Rover 800 Series

Designed in conjunction with the Honda Motor Company of Japan, the Rover 800 series was launched in the UK in July 1986 as a replacement for the ageing Rover SD1. Initially available in four-door Saloon guise, a Fastback version was added to the range in mid-1988. Minor styling revisions were applied to various models in the intervening years, culminating in a major facelift to all models for the 1992 model year. This saw the introduction of the "second generation" Rover 800 series with significant styling and engineering revisions, together with the launch of the Coupe model later in the same year.

Three different engines are used in the Rover models covered by this manual. 820 models are powered by a 2.0 litre, 4-cylinder, sixteen valve engine with single-point or multi-point fuel injection. The early version of this power unit is based on the proven O-series engine used previously in the Montego and earlier Austin Rover vehicles, but with an all new cylinder head and valve train. For the 1992 model year the T-series version was announced which shared many of the O-series components but with significant revisions in many areas. Both these engines

are available in normally aspirated or turbocharged versions.

825, 827 and Sterling models are powered by a 2.5 or 2.7 litre V6 twenty four valve engine with programmed fuel injection. Both versions of this engine are virtually identical apart from an increase in cylinder bore diameter to provide the larger capacity of the 2.7 litre unit.

On all models, the engine is mounted transversely at the front of the car and drives the front wheels through a five-speed manual, or four speed automatic transmission.

Suspension is independent at the front by double wishbones and coil springs, and at the rear by transverse links and coil springs. Power-assisted steering is standard on all models.

A comprehensive range of electrical and interior features are offered as standard equipment, including electric front windows, central locking and stereo radio cassette player. Anti-lock braking, air conditioning, headlight wash, electric rear windows, driver and passenger airbags and many other features and accessories are also available as optional or standard equipment according to model.

## Acknowledgements

Thanks are due to Champion Spark Plug, who supplied the illustrations showing spark plug conditions. Thanks are also due to Sykes-Pickavant Limited, who provided some of the workshop tools, and to all those people at Sparkford who helped in the production of this manual.

**We take great pride in the accuracy of information given in this manual, but vehicle manufacturers make alterations and design changes during the production run of a particular vehicle of which they do not inform us. No liability can be accepted by the authors or publishers for loss, damage or injury caused by any errors in, or omissions from, the information given.**

## Project vehicles

The main project vehicle used in the preparation of this manual, and appearing in many of the photographic sequences was a 1986 Rover 820 Se Saloon. Additional work was carried out and photographed on a 1988 Rover 820 Si Fastback and a 1992 Rover Sterling.



Rover 820i Saloon



Rover 800 Coupe

Working on your car can be dangerous. This page shows just some of the potential risks and hazards, with the aim of creating a safety-conscious attitude.

## General hazards

### Scalding

- Don't remove the radiator or expansion tank cap while the engine is hot.
- Engine oil, automatic transmission fluid or power steering fluid may also be dangerously hot if the engine has recently been running.

### Burning

- Beware of burns from the exhaust system and from any part of the engine. Brake discs and drums can also be extremely hot immediately after use.

### Crushing

- When working under or near a raised vehicle, always supplement the jack with axle stands, or use drive-on ramps.

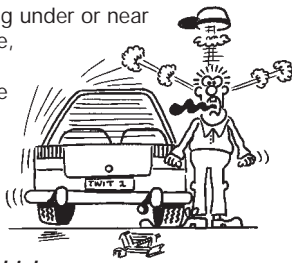

**Never venture under a car which is only supported by a jack.**

- Take care if loosening or tightening high-torque nuts when the vehicle is on stands. Initial loosening and final tightening should be done with the wheels on the ground.

### Fire

- Fuel is highly flammable; fuel vapour is explosive.
- Don't let fuel spill onto a hot engine.
- Do not smoke or allow naked lights (including pilot lights) anywhere near a vehicle being worked on. Also beware of creating sparks (electrically or by use of tools).
- Fuel vapour is heavier than air, so don't work on the fuel system with the vehicle over an inspection pit.
- Another cause of fire is an electrical overload or short-circuit. Take care when repairing or modifying the vehicle wiring.
- Keep a fire extinguisher handy, of a type suitable for use on fuel and electrical fires.

### Electric shock

- Ignition HT voltage can be dangerous, especially to people with heart problems or a pacemaker. Don't work on or near the ignition system with the engine running or the ignition switched on.

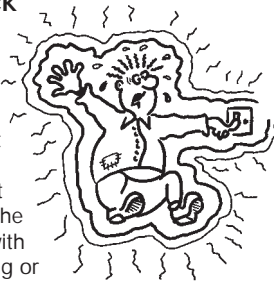

- Mains voltage is also dangerous. Make sure that any mains-operated equipment is correctly earthed. Mains power points should be protected by a residual current device (RCD) circuit breaker.

### Fume or gas intoxication

- Exhaust fumes are poisonous; they often contain carbon monoxide, which is rapidly fatal if inhaled. Never run the engine in a confined space such as a garage with the doors shut.
- Fuel vapour is also poisonous, as are the vapours from some cleaning solvents and paint thinners.

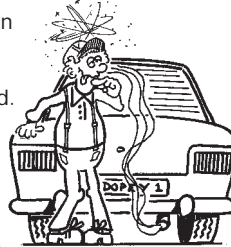

### Poisonous or irritant substances

- Avoid skin contact with battery acid and with any fuel, fluid or lubricant, especially antifreeze, brake hydraulic fluid and Diesel fuel. Don't syphon them by mouth. If such a substance is swallowed or gets into the eyes, seek medical advice.
- Prolonged contact with used engine oil can cause skin cancer. Wear gloves or use a barrier cream if necessary. Change out of oil-soaked clothes and do not keep oily rags in your pocket.
- Air conditioning refrigerant forms a poisonous gas if exposed to a naked flame (including a cigarette). It can also cause skin burns on contact.

### Asbestos

- Asbestos dust can cause cancer if inhaled or swallowed. Asbestos may be found in gaskets and in brake and clutch linings. When dealing with such components it is safest to assume that they contain asbestos.

## Special hazards

### Hydrofluoric acid

- This extremely corrosive acid is formed when certain types of synthetic rubber, found in some O-rings, oil seals, fuel hoses etc, are exposed to temperatures above 400°C. The rubber changes into a charred or sticky substance containing the acid. *Once formed, the acid remains dangerous for years. If it gets onto the skin, it may be necessary to amputate the limb concerned.*
- When dealing with a vehicle which has suffered a fire, or with components salvaged from such a vehicle, wear protective gloves and discard them after use.

### The battery

- Batteries contain sulphuric acid, which attacks clothing, eyes and skin. Take care when topping-up or carrying the battery.
- The hydrogen gas given off by the battery is highly explosive. Never cause a spark or allow a naked light nearby. Be careful when connecting and disconnecting battery chargers or jump leads.

### Air bags

- Air bags can cause injury if they go off accidentally. Take care when removing the steering wheel and/or facia. Special storage instructions may apply.

**Warning: Never expose the hands, face or any other part of the body to injector spray; the fuel can penetrate the skin with potentially fatal results.**

## Remember...

### DO

- Do use eye protection when using power tools, and when working under the vehicle.
- Do wear gloves or use barrier cream to protect your hands when necessary.
- Do get someone to check periodically that all is well when working alone on the vehicle.
- Do keep loose clothing and long hair well out of the way of moving mechanical parts.
- Do remove rings, wristwatch etc, before working on the vehicle – especially the electrical system.
- Do ensure that any lifting or jacking equipment has a safe working load rating adequate for the job.

### DON'T

- Don't attempt to lift a heavy component which may be beyond your capability – get assistance.
- Don't rush to finish a job, or take unverified short cuts.
- Don't use ill-fitting tools which may slip and cause injury.
- Don't leave tools or parts lying around where someone can trip over them. Mop up oil and fuel spills at once.
- Don't allow children or pets to play in or near a vehicle being worked on.

# 0.6 General dimensions and weights

---

## Dimensions

Overall length:	
Pre-1992 model year	4694.0 mm
1992 model year onwards	4882.0 mm
Overall width - including mirrors:	
Pre-1992 model year	1946.0 mm
1992 model year onwards:	
Saloon and Fastback models	1965.0 mm
Coupe models	1900.0 mm
Overall height (unladen):	
Pre-1992 model year	1398.0 mm
1992 model year onwards:	
Saloon and Fastback models	1363.0 mm
Coupe models	1400.0 mm
Wheelbase	2760.0 mm
Front track	1490.0 mm
Rear track	1450.0 mm
Ground clearance	145.0 mm

## Weights

Kerb weight*:	
820 Saloon models	1305 to 1405 kg
820 Fastback models	1335 to 1435 kg
820 Coupe models	1420 kg
825 and Sterling Saloon models	1360 to 1400 kg
827 and Sterling Saloon models	1400 to 1470 kg
827 and Sterling Fastback models	1410 to 1510 kg
827 Coupe models	1450 kg
Maximum roof rack load:	
Saloon and Fastback models	70 kg
Coupe models	50 kg
Maximum towing weight:	
820 models with manual transmission:	
Braked trailer (all models except Turbo)	1550 kg
Braked trailer (Turbo models)	1025 kg
Unbraked trailer	500 kg
820 models with automatic transmission:	
Braked trailer	1025 kg
Unbraked trailer	500 kg
825, 827 and Sterling models:	
Braked trailer**	1550 kg
Unbraked trailer	500 kg
Maximum towing hitch downward load	70 kg

\*Depending on model and specification - refer to Rover dealer for exact recommendations.

\*\*On automatic transmission models, an auxiliary fluid cooler must be fitted if the towing weight is to exceed 1000 kg.

## Jacking, towing and wheel changing

### Jacking

The jack supplied with the vehicle tool kit should only be used for changing the roadwheels - see "Wheel changing" later in this Section. When carrying out any other kind of work, raise the vehicle using a hydraulic (or "trolley") jack, and always supplement the jack with axle stands positioned under the vehicle jacking points (see illustration).

When using a hydraulic jack or axle stands, always position the jack head or axle stand

head under one of the relevant jacking points.

To raise the front of the vehicle, position the jack head under the front towing eye which is welded to the longitudinal support member running under the engine. Do not position the jack under the longitudinal member itself, or under the sump or any of the steering or suspension components.

To raise the rear of the vehicle, position the jack head under the rear towing eye which is welded to the reinforcement panel under the spare wheel carrier.

If the side of the vehicle is to be raised, position the jack head under the reinforced areas at the front or rear of the side sills.

The jack supplied with the vehicle also locates in the reinforced areas of the side sills. Ensure that the jack head is correctly engaged before attempting to raise the vehicle.

**Never** work under, around or near a raised vehicle unless it is adequately supported in at least two places.

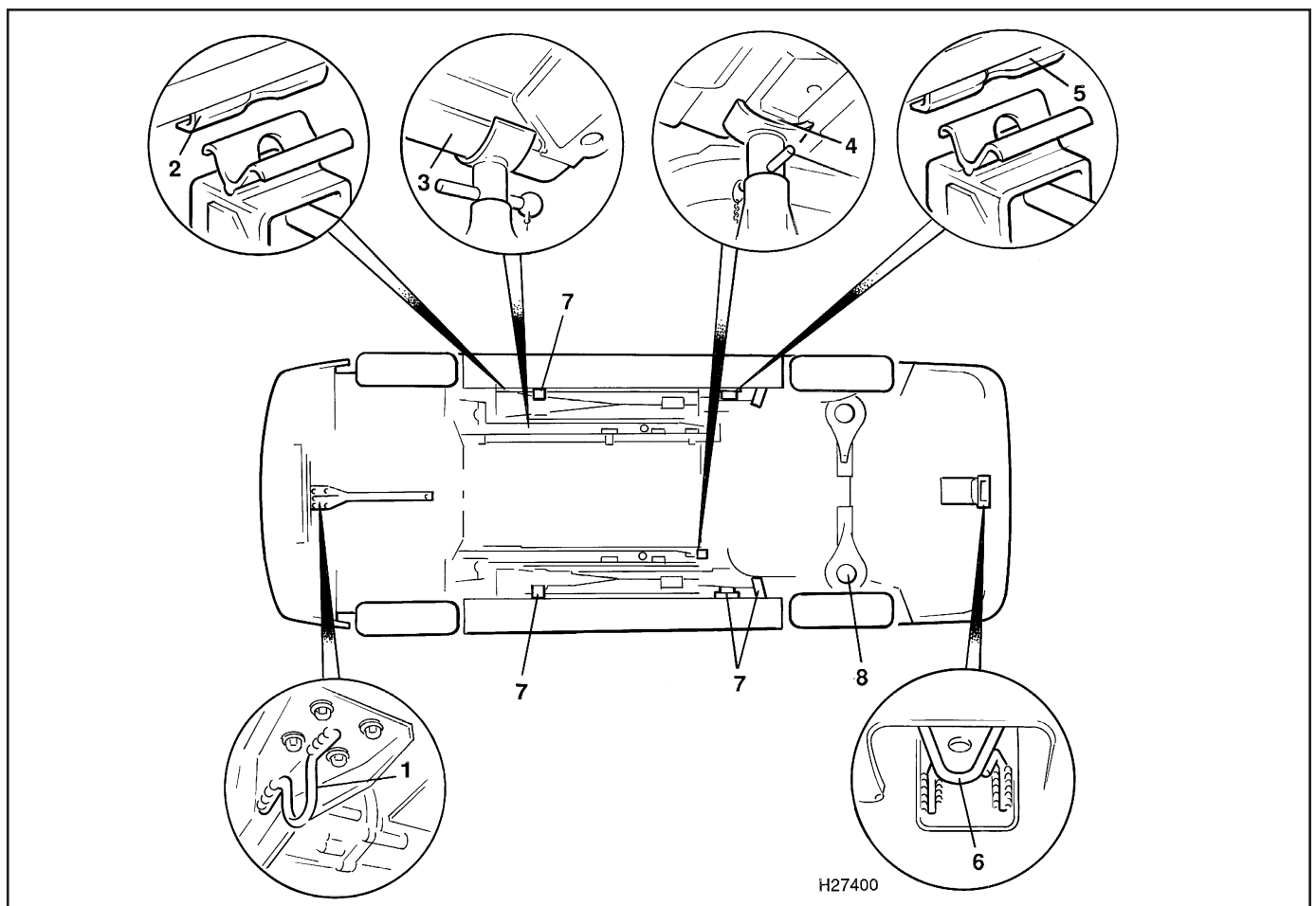

Jacking points and axle stand locations

- |   |   |
|---|---|
| 1 Front towing eye - used for raising the front of the car                                  | 5 Reinforced sill area - used for raising the side of the car, or supporting on axle stands |
| 2 Reinforced sill area - used for raising the side of the car, or supporting on axle stands | 6 Rear towing eye - used for raising the rear of the car                                    |
| 3 Front chassis member - used for supporting the car on axle stands                         | 7 Square tubular chassis sections - <b>Not suitable for jacking or supporting</b>           |
| 4 Rear chassis member - used for supporting the car on axle stands                          | 8 Suspension components - <b>Not suitable for jacking or supporting</b>                     |



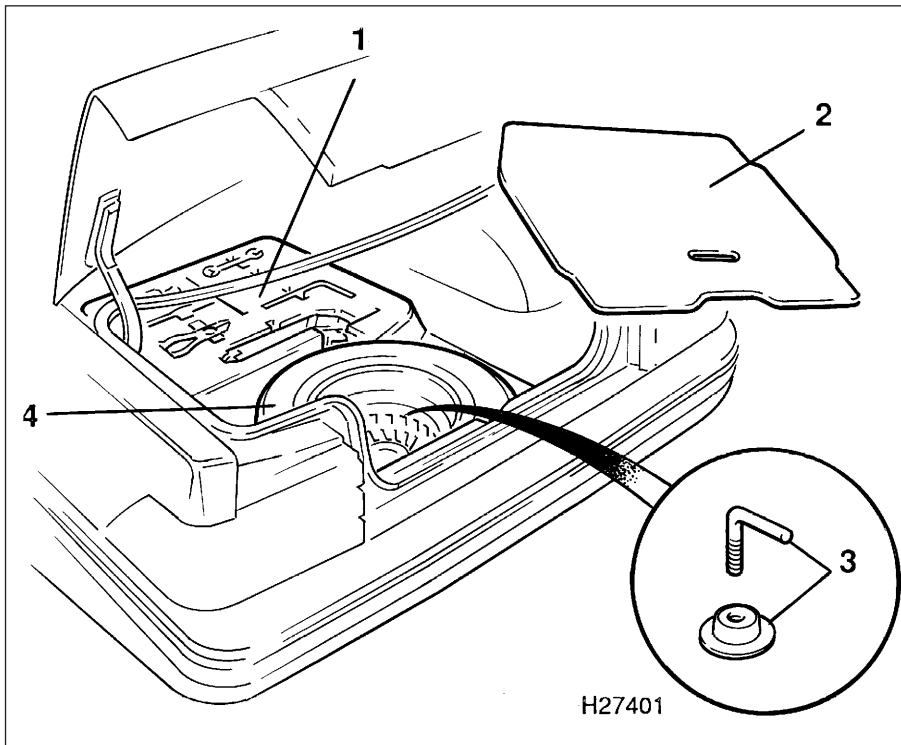

Spare wheel and tool locations

- |               |                     |
|---------------|---------------------|
| 1 Tool kit    | 3 Spare wheel clamp |
| 2 Floor panel | 4 Spare wheel       |

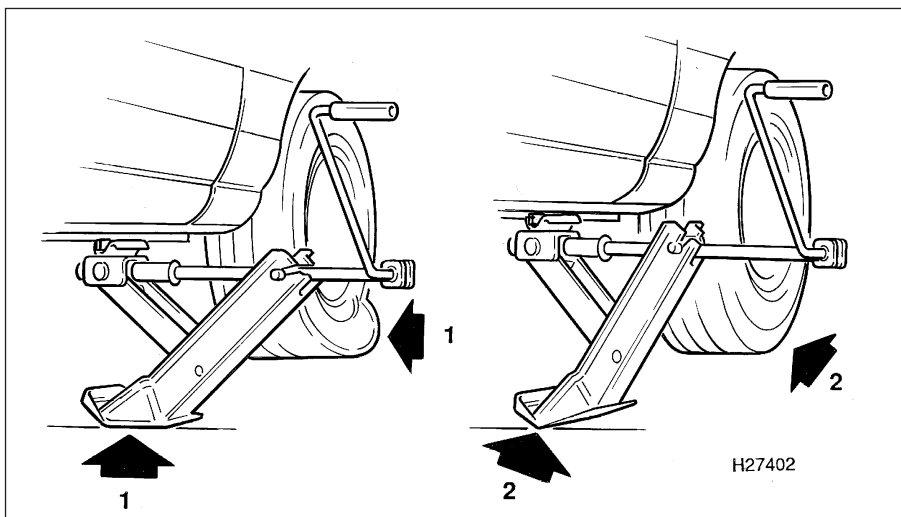

Using the vehicle tool kit jack

- 1 Jack base positioned flat on the ground (deflated tyre)
- 2 Jack positioned with base elbow on the ground, and base just clear (inflated tyre)

## Towing

Towing eyes are fitted to the front and rear of the vehicle for attachment of a tow rope. The front towing eye is situated under the centre of the front bumper and the rear towing eye is located under the centre of the rear bumper behind a detachable trim plate.

Always turn the ignition key to position II to ensure that the steering is unlocked and that the various switches (indicators and lights) are functional. It should also be noted that the brake servo and power-assisted steering will not be operating with the engine switched off and therefore an allowance will need to be made for reduced braking efficiency and increased steering effort.

Before being towed, release the handbrake and place the gear lever in neutral. Do not tow at a speed greater than 30 mph. On no account may the car be towed with the front wheels on the ground if the transmission is faulty, if the transmission oil or fluid is low or if the towing distance is greater than 30 miles.

## Wheel changing

To change a roadwheel, first remove the spare wheel and jack which are located under the luggage compartment floor (see illustration). Firmly apply the handbrake and engage first gear on manual transmission models or PARK on automatic transmission models. Place chocks at the front and rear of the wheel diagonally opposite the one to be changed.

Remove the wheel trim and slacken the wheel nuts with the tools provided in the tool kit. Position the jack head in the reinforced jacking point, at the base of the sill nearest to the wheel to be changed. Raise the jack to just take the weight of the car. If the tyre is flat, position the base of the jack so that it is flat on the ground. If the tyre is not flat, position the jack so that the base elbow is resting on the ground and the base is just clear (see illustration). Raise the vehicle until the wheel is just clear of the ground, then remove the wheel nuts and the wheel. Fit the spare wheel and screw on the wheel nuts. Lower the jack until the tyre is just touching the ground, and tighten the wheel nuts moderately tight. Now lower the jack fully and tighten the wheel nuts securely in a diagonal sequence. Refit the wheel trim, then remove the jack and stow it together with the wheel and tools in the luggage compartment. Remember to check the tightness of the wheel nuts using a torque wrench at the earliest opportunity.



## Jump starting

### HAYNES HiNT

Jump starting will get you out of trouble, but you must correct whatever made the battery go flat in the first place. There are three possibilities:

- 1** The battery has been drained by repeated attempts to start, or by leaving the lights on.
- 2** The charging system is not working properly (alternator drivebelt slack or broken, alternator wiring fault or alternator itself faulty).
- 3** The battery itself is at fault (electrolyte low, or battery worn out).

When jump-starting a car using a booster battery, observe the following precautions:

- ✓ Before connecting the booster battery, make sure that the ignition is switched off.
- ✓ Ensure that all electrical equipment (lights, heater, wipers, etc) is switched off.

- ✓ Make sure that the booster battery is the same voltage as the discharged one in the vehicle.
- ✓ If the battery is being jump-started from the battery in another vehicle, the two vehicles **MUST NOT TOUCH** each other.
- ✓ Make sure that the transmission is in neutral (or PARK, in the case of automatic transmission).



**1** Connect one end of the red jump lead to the positive (+) terminal of the flat battery



**2** Connect the other end of the red lead to the positive (+) terminal of the booster battery.



**3** Connect one end of the black jump lead to the negative (-) terminal of the booster battery

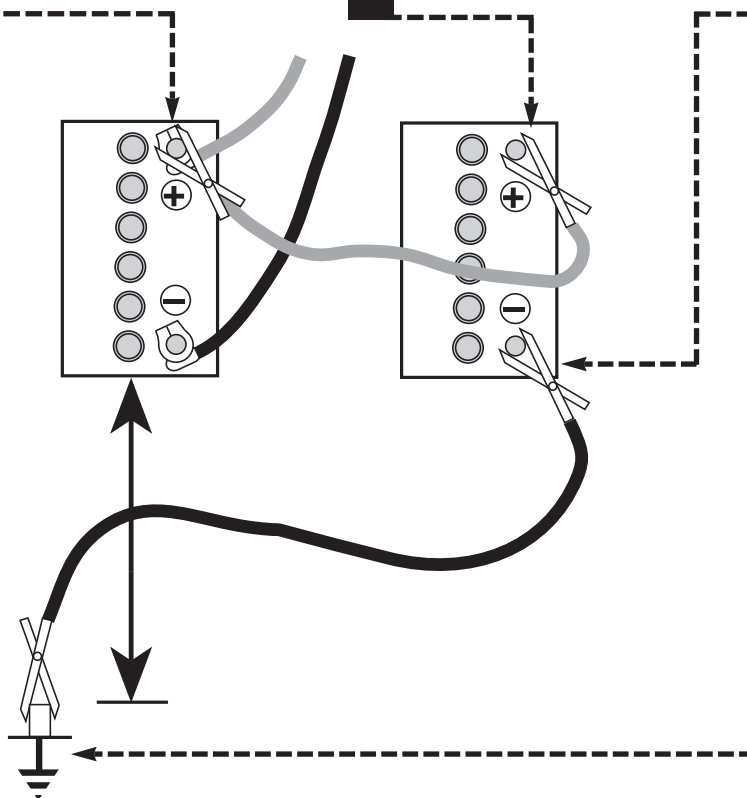

**4** Connect the other end of the black jump lead to a bolt or bracket on the engine block, well away from the battery, on the vehicle to be started.

**5** Make sure that the jump leads will not come into contact with the fan, drivebelts or other moving parts of the engine.

**6** Start the engine using the booster battery, then with the engine running at idle speed, disconnect the jump leads in the reverse order of connection.

## Identifying leaks

Puddles on the garage floor or drive, or obvious wetness under the bonnet or underneath the car, suggest a leak that needs investigating. It can sometimes be difficult to decide where the leak is coming from, especially if the engine bay is very dirty already. Leaking oil or fluid can also be blown rearwards by the passage of air under the car, giving a false impression of where the problem lies.



**Warning:** Most automotive oils and fluids are poisonous. Wash them off skin, and change out of contaminated clothing, without delay.



The smell of a fluid leaking from the car may provide a clue to what's leaking. Some fluids are distinctively coloured. It may help to clean the car carefully and to park it over some clean paper overnight as an aid to locating the source of the leak. Remember that some leaks may only occur while the engine is running.

### Sump oil



Engine oil may leak from the drain plug...

### Oil from filter



...or from the base of the oil filter.

### Gearbox oil

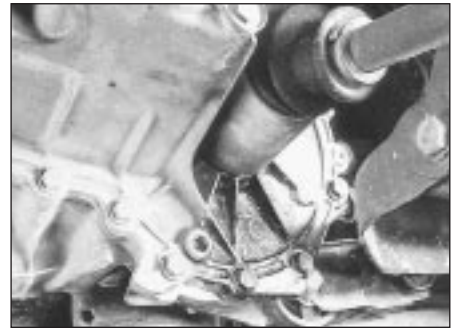

Gearbox oil can leak from the seals at the inboard ends of the driveshafts.

### Antifreeze



Leaking antifreeze often leaves a crystalline deposit like this.

### Brake fluid



A leak occurring at a wheel is almost certainly brake fluid.

### Power steering fluid

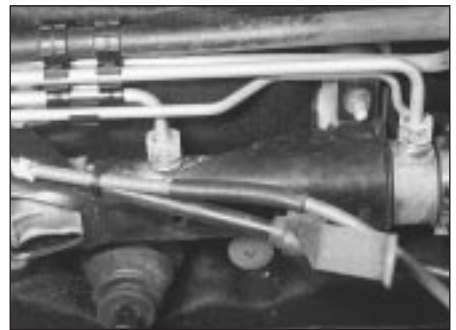

Power steering fluid may leak from the pipe connectors on the steering rack.

## Radio/cassette unit anti-theft system - precaution

The radio/cassette unit fitted as standard equipment by Rover is equipped with a built-in security code, to deter thieves. If the power source to the unit is cut, the anti-theft system will activate. Even if the power source is immediately reconnected, the radio/cassette unit will not function until the correct security

code has been entered. Therefore, if you do not know the correct security code for the radio/cassette unit **do not** disconnect either of the battery terminals, or remove the radio/cassette unit from the vehicle.

To enter the correct security code, follow

the instructions provided with the radio/cassette player handbook.

If an incorrect code is entered, the unit will become locked, and cannot be operated.

If this happens, or if the security code is lost or forgotten, seek the advice of your Rover dealer.

## Length (distance)

Inches (in)	x 25.4 = Millimetres (mm)	x 0.0394 = Inches (in)
Feet (ft)	x 0.305 = Metres (m)	x 3.281 = Feet (ft)
Miles	x 1.609 = Kilometres (km)	x 0.621 = Miles

## Volume (capacity)

Cubic inches (cu in; in <sup>3</sup> )	x 16.387 = Cubic centimetres (cc; cm <sup>3</sup> )	x 0.061 = Cubic inches (cu in; in <sup>3</sup> )
Imperial pints (Imp pt)	x 0.568 = Litres (l)	x 1.76 = Imperial pints (Imp pt)
Imperial quarts (Imp qt)	x 1.137 = Litres (l)	x 0.88 = Imperial quarts (Imp qt)
Imperial quarts (Imp qt)	x 1.201 = US quarts (US qt)	x 0.833 = Imperial quarts (Imp qt)
US quarts (US qt)	x 0.946 = Litres (l)	x 1.057 = US quarts (US qt)
Imperial gallons (Imp gal)	x 4.546 = Litres (l)	x 0.22 = Imperial gallons (Imp gal)
Imperial gallons (Imp gal)	x 1.201 = US gallons (US gal)	x 0.833 = Imperial gallons (Imp gal)
US gallons (US gal)	x 3.785 = Litres (l)	x 0.264 = US gallons (US gal)

## Mass (weight)

Ounces (oz)	x 28.35 = Grams (g)	x 0.035 = Ounces (oz)
Pounds (lb)	x 0.454 = Kilograms (kg)	x 2.205 = Pounds (lb)

## Force

Ounces-force (ozf; oz)	x 0.278 = Newtons (N)	x 3.6 = Ounces-force (ozf; oz)
Pounds-force (lbf; lb)	x 4.448 = Newtons (N)	x 0.225 = Pounds-force (lbf; lb)
Newton (N)	x 0.1 = Kilograms-force (kgf; kg)	x 9.81 = Newtons (N)

## Pressure

Pounds-force per square inch (psi; lbf/in <sup>2</sup> ; lb/in <sup>2</sup> )	x 0.070 = Kilograms-force per square centimetre (kgf/cm <sup>2</sup> ; kg/cm <sup>2</sup> )	x 14.223 = Pounds-force per square inch (psi; lbf/in <sup>2</sup> ; lb/in <sup>2</sup> )
Pounds-force per square inch (psi; lbf/in <sup>2</sup> ; lb/in <sup>2</sup> )	x 0.068 = Atmospheres (atm)	x 14.696 = Pounds-force per square inch (psi; lbf/in <sup>2</sup> ; lb/in <sup>2</sup> )
Pounds-force per square inch (psi; lbf/in <sup>2</sup> ; lb/in <sup>2</sup> )	x 0.069 = Bars	x 14.5 = Pounds-force per square inch (psi; lbf/in <sup>2</sup> ; lb/in <sup>2</sup> )
Pounds-force per square inch (psi; lbf/in <sup>2</sup> ; lb/in <sup>2</sup> )	x 6.895 = Kilopascals (kPa)	x 0.145 = Pounds-force per square inch (psi; lbf/in <sup>2</sup> ; lb/in <sup>2</sup> )
Kilopascals (kPa)	x 0.01 = Kilograms-force per square centimetre (kgf/cm <sup>2</sup> ; kg/cm <sup>2</sup> )	x 98.1 = Kilopascals (kPa)
Millibar (mbar)	x 100 = Pascals (Pa)	x 0.01 = Millibar (mbar)
Millibar (mbar)	x 0.0145 = Pounds-force per square inch (psi; lbf/in <sup>2</sup> ; lb/in <sup>2</sup> )	x 68.947 = Millibar (mbar)
Millibar (mbar)	x 0.75 = Millimetres of mercury (mmHg)	x 1.333 = Millibar (mbar)
Millibar (mbar)	x 0.401 = Inches of water (inH <sub>2</sub> O)	x 2.491 = Millibar (mbar)
Millimetres of mercury (mmHg)	x 0.535 = Inches of water (inH <sub>2</sub> O)	x 1.868 = Millimetres of mercury (mmHg)
Inches of water (inH <sub>2</sub> O)	x 0.036 = Pounds-force per square inch (psi; lbf/in <sup>2</sup> ; lb/in <sup>2</sup> )	x 27.68 = Inches of water (inH <sub>2</sub> O)

## Torque (moment of force)

Pounds-force inches (lbf in; lb in)	x 1.152 = Kilograms-force centimetre (kgf cm; kg cm)	x 0.868 = Pounds-force inches (lbf in; lb in)
Pounds-force inches (lbf in; lb in)	x 0.113 = Newton metres (Nm)	x 8.85 = Pounds-force inches (lbf in; lb in)
Pounds-force inches (lbf in; lb in)	x 0.083 = Pounds-force feet (lbf ft; lb ft)	x 12 = Pounds-force inches (lbf in; lb in)
Pounds-force feet (lbf ft; lb ft)	x 0.138 = Kilograms-force metres (kgf m; kg m)	x 7.233 = Pounds-force feet (lbf ft; lb ft)
Pounds-force feet (lbf ft; lb ft)	x 1.356 = Newton metres (Nm)	x 0.738 = Pounds-force feet (lbf ft; lb ft)
Newton metres (Nm)	x 0.102 = Kilograms-force metres (kgf m; kg m)	x 9.804 = Newton metres (Nm)

## Power

Horsepower (hp)	x 745.7 = Watts (W)	x 0.0013 = Horsepower (hp)
-----------------	---------------------	----------------------------

## Velocity (speed)

Miles per hour (miles/hr; mph)	x 1.609 = Kilometres per hour (km/hr; kph)	x 0.621 = Miles per hour (miles/hr; mph)
--------------------------------	--	--

## Fuel consumption\*

Miles per gallon (mpg)	x 0.354 = Kilometres per litre (km/l)	x 2.825 = Miles per gallon (mpg)
------------------------	---------------------------------------	----------------------------------

## Temperature

Degrees Fahrenheit = (°C x 1.8) + 32                      Degrees Celsius (Degrees Centigrade; °C) = (°F - 32) x 0.56

\* It is common practice to convert from miles per gallon (mpg) to litres/100 kilometres (l/100km), where mpg x l/100 km = 282

# Chapter 1

## Routine maintenance and servicing

### Contents

Accelerator cable and linkage check and lubrication	10	Exhaust system check	23
Air cleaner element renewal	12	Fluid level checks	3
Air conditioning system check	18	Fuel filter renewal	34
Automatic transmission fluid level check	31	Introduction	1
Automatic transmission fluid renewal	35	Manual transmission oil level check	20
Auxiliary drivebelts check and renewal	16	Manual transmission oil renewal	37
Battery check, maintenance and charging	14	Positive Crankcase Ventilation (PCV) system check	33
Bodywork, paint and exterior trim check	28	Power steering fluid level check	5
Brake check	26	Road test	30
Brake fluid renewal	36	Roadwheel nut tightness check	29
Braking system hydraulic fluid seal check and renewal	40	Routine maintenance	2
Clutch operation and hydraulic hose condition check	25	Seat belt check	15
Coolant renewal	38	Spark plug renewal	11
Cooling system check	9	Steering, suspension and roadwheel check	21
Door, boot, tailgate and bonnet check and lubrication	27	Timing belt condition and tension check	32
Driveshaft rubber gaiter and CV joint check	22	Timing belt renewal	39
Electrical system check	13	Tyre and tyre pressure checks	4
Emissions control equipment check	41	Underbody and fuel/brake line check	24
Engine base idle speed and CO content check	19	Underbonnet check for fluid leaks and hose condition	8
Engine compartment wiring check	17	Windscreen/tailgate and headlight washer system and wiper blade check	6
Engine oil and filter change	7		

### Degrees of difficulty

<b>Easy</b> , suitable for novice with little experience 	<b>Fairly easy</b> , suitable for beginner with some experience 	<b>Fairly difficult</b> , suitable for competent DIY mechanic 	<b>Difficult</b> , suitable for experienced DIY mechanic 	<b>Very difficult</b> , suitable for expert DIY or professional 
---	--	--	---	--

### Specifications

#### Engine

Direction of crankshaft rotation ..... Clockwise (seen from right-hand side of vehicle)

#### Oil filter:

4-cylinder engines	Champion B101
V6 engines:	
paper type	Champion X119
cannister type	Champion E102

#### Cooling system

Coolant protection at 33% antifreeze/water mixture ratio:

Slush point	-19°C (-2°F)
Solidifying point	-36°C (-33°F)

Coolant protection at 50% antifreeze/water mixture ratio:

Slush point	-36°C (-33°F)
Solidifying point	-48°C (-54°F)

#### Fuel system

Air filter element:

"M" series 4-cylinder engines	Champion W114
"T" series 4-cylinder engines	Champion type not available
V6 engines	Champion W601

Fuel filter:

4-cylinder engines	Champion L208
V6 engines	Champion L207

## 1.2 Specifications

### Ignition system

Firing order:	
4-cylinder engines	1-3-4-2 (No 1 cylinder at timing belt end)
V6 engines	1-4-2-5-3-6 (No 1 cylinder at timing belt end on rear bank)
Spark plugs:	
Type: *	
4-cylinder normally aspirated engines	Champion RC9YCC
4-cylinder turbocharged engines up to 1992 model year	Champion RC7YCC
4-cylinder turbocharged engines 1992 model year onwards	Champion RC9YCC
V6 engines	Champion RC9YCC4
Electrode gap: *	
4-cylinder engines	0.8 mm
V6 engines	1.0 mm
Spark plug (HT) leads:	
Type:	
4-cylinder engines	Champion LS-05 boxed set
V6 engines	Champion boxed set not available
Maximum resistance per lead	30 000 ohms

\* Information on spark plug types and electrode gaps is as recommended by Champion Spark Plug.

Where alternative types are used, refer to their manufacturer's recommendations

### Braking system

Front brake pad thickness (including backing but excluding shims):	
New	17.4 mm
Minimum	8.2 mm
Rear brake pad thickness (including backing):	
New	14.5 mm
Minimum	7.2 mm

### Tyres

Tyre pressures (cold):	Front	Rear
195/70 VR 14 tyres	1.8 bar (26 psi)	1.8 bar (26 psi)
195/65 VR 15 tyres	2.0 bar (28 psi)	2.0 bar (28 psi)
205/55 VR or ZR 16 tyres	2.2 bar (32 psi)	2.2 bar (32 psi)
205/60 VR 15 tyres	2.0 bar (28 psi)	2.0 bar (28 psi)
215/45 ZR 17 tyres	2.3 bar (34 psi)	1.9 bar (28 psi)
115/70 R 15 (space saver spare tyre)	4.1 bar (60 psi)	4.1 bar (60 psi)

**Note:** For sustained high speeds above 100 mph (160 km/h), increased pressures are necessary.

Consult the driver's handbook supplied with the vehicle.

### Wiper blades

Windscreen	Champion X-5103
Tailgate/rear window	Champion X-5103

### Torque wrench settings

	Nm	lbf ft
Power steering pump bolts:		
4-cylinder engines - rear-mounted pump	25	18
4-cylinder engines - front-mounted pump:		
Early version (4 mounting bolts)	10	7
Later version (5 mounting bolts)	25	18
V6 engines:		
Mounting bolt	39	29
Adjusting nut	22	16
Power steering pump drivebelt tensioner wheel retaining nut (4-cylinder engines - rear mounted pump)	45	33
Alternator pivot and mounting bolts (4-cylinder engines)	25	18
Alternator adjustment bracket bolts (4-cylinder engines)	12	9
Alternator side pivot bolt (V6 engines)	45	33
Alternator lower mounting nut (V6 engines)	24	17
Engine oil drain plug	45	33
Manual transmission filler/level and drain plugs	45	33
Automatic transmission drain plugs:		
4-cylinder engines	15	11
V6 engines	40	30
Spark plugs:		
4-cylinder engines up to 1991	18	13
4-cylinder engines from 1991 onward	25	18
V6 engines	18	13
Roadwheel nuts	110	81

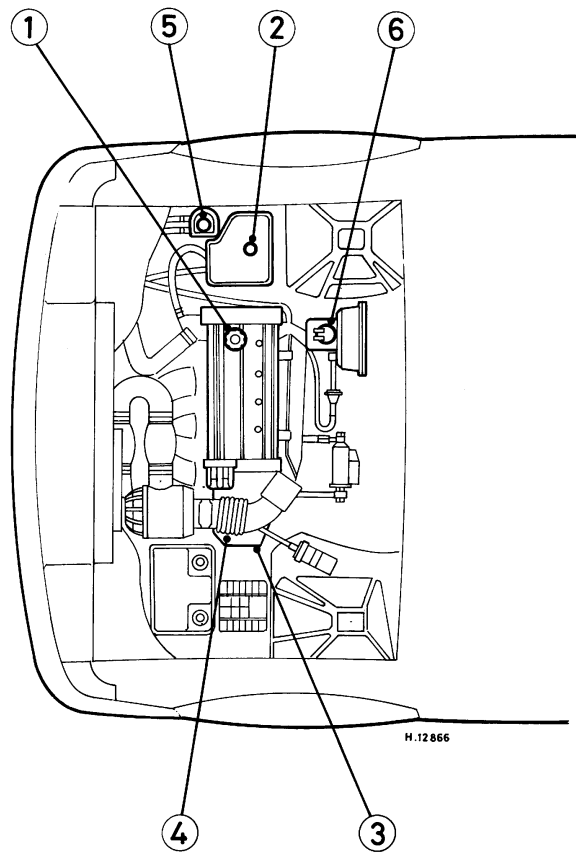

## Lubricants and fluids

### Component or system

1 Engine

### Lubricant type/specification

Multigrade engine oil to specification API SG/CD or better, viscosity range 5W/50 to 10W/40

2 Cooling system

Soft water, and antifreeze (ethylene glycol-based, suitable for use in mixed-metal cooling systems)

3 Manual transmission

Multigrade engine oil to specification API SG/CD or better, viscosity 10W/40

4 Automatic transmission

Dexron IID type ATF

5 Power steering fluid reservoir

Dexron IID type ATF

6 Brake and clutch fluid reservoir

Hydraulic fluid to FMVSS 116 DOT 4

### General greasing

Multipurpose lithium based grease

## Capacities

Engine oil (including filter) . . . . .	4.5 litres
Cooling system:	
4-cylinder engines:	
" M " series engines . . . . .	10.0 litres
" T " series engines . . . . .	8.0 litres
V6 engines:	
2.5 litre engines . . . . .	10.0 litres
2.7 litre engines . . . . .	8.6 litres
Manual transmission (drain and refill) . . . . .	2.3 litres
Automatic transmission (drain and refill):	
4-cylinder engines . . . . .	2.0 litres
V6 engines . . . . .	3.2 litres
Power steering reservoir . . . . .	1.5 litres
Fuel tank . . . . .	68 litres



### Rover 800 Series maintenance schedule

---

The manufacturer's recommended maintenance schedule for these vehicles is as described below - note that the schedule starts from the vehicle's date of registration. These are the minimum maintenance intervals recommended by the factory for vehicles driven daily, but subjected only to "normal" use. If you wish to keep your car in peak condition at all times, you may wish to perform some of these procedures even more often. Because frequent maintenance enhances the efficiency, performance and resale value of your car, we encourage you to do so. If your usage is not "normal", shorter intervals are also recommended - the most important examples of

these are noted in the schedule. These shorter intervals apply particularly if you drive in dusty areas, tow a caravan or trailer, sit with the engine idling or drive at low speeds for extended periods (ie, in heavy traffic), or drive for short distances (less than four miles) in below-freezing temperatures.

Although the manufacturer's intervals have been extended to one main service at 12 000 mile (12 monthly) intervals for 1994 models onward, the earlier schedule which also includes a lubrication service at 6000 mile (6 monthly) intervals, is the schedule shown in this Chapter.

#### Weekly checks

- Check the engine oil level, and top-up if necessary (Section 3).
- Check the brake fluid level, and top-up if necessary (Section 3). If repeated topping-up is required, check the system for leaks or damage at the earliest possible opportunity (Section 24).
- Check the windscreen/tailgate and headlight washer fluid level, and top-up if necessary (Section 3).
- Check the tyre pressures, including the spare (Section 4).
- Visually check the tyres for excessive tread wear, or damage (Section 4).
- Check the operation of all (exterior and interior) lights and the horn, wipers and windscreen/tailgate washer system (Sections 6 and 13).
- Renew any blown bulbs (Chapter 12), and clean the lenses of all exterior lights.
- Check the coolant level, and top-up if necessary (Section 3).
- Check the battery electrolyte level, where applicable (Section 3).
- Check the power steering fluid level, and top-up if necessary (Section 5).
- Check the aim of the windscreen/tailgate/headlight washer jets, correcting them if required (Section 6).
- Check the condition of the wiper blades, renewing them if worn or no longer effective (Section 6).
- Visually check all reservoirs, hoses and pipes for leakage (Section 8).
- Check the operation of the air conditioning system (where applicable) (Section 18).

#### Every 6000 miles (10 000 km) or 6 months, whichever occurs first

- Change the engine oil and filter (Section 7).
- Check under the bonnet for fluid leaks and hose condition (Section 8).

#### Every 12 000 miles (20 000 km) or 12 months, whichever occurs first

- Check the cooling system (Section 9).
- Check the operation of the accelerator cable and linkage (Section 10).
- Renew the spark plugs (models without emission control equipment) (Section 11).
- Renew the air cleaner filter element (models without emission control equipment) (Section 12).
- Check the electrical system (Section 13).
- Check the battery (Section 14).
- Check the seat belts (Section 15).
- Check the auxiliary drivebelt(s) (Section 16).
- Check the condition of all engine compartment wiring (Section 17).
- Check the condition of all air conditioning system components (where applicable) (Section 18).
- Check the engine idle speed and mixture (where applicable) (Section 19).
- Check the manual transmission oil level (Section 20).
- Check the steering, suspension and roadwheels (Section 21).
- Check the driveshaft rubber gaiters and CV joints (Section 22).
- Check the exhaust system (Section 23).
- Check the underbody, and all fuel/brake lines (Section 24).
- Check the clutch operation and hydraulic hose condition (Section 25).
- Check the brake system (Section 26).
- Check the doors and bonnet, and lubricate their hinges and locks (Section 27).
- Check the condition of the bodywork and all exterior trim (Section 28).
- Check the security of all roadwheel nuts (Section 29).
- Road test (Section 30).
- Check the level of the automatic transmission fluid after road test (Section 31).



## Every 24 000 miles (40 000 km) or 2 years, whichever occurs first

- Renew the spark plugs (models with emission control equipment) (Section 11).
- Renew the air cleaner filter element (models with emission control equipment) (Section 12).
- Check the condition and tension of the timing belt (Section 32).
- Check the Positive Crankcase Ventilation system (Section 33).
- Renew the fuel filter (Section 34).
- Renew the automatic transmission fluid (Section 35).
- Renew the brake fluid (Section 36).
- Renew the manual transmission oil (Section 37).
- Renew the coolant (Section 38).

## Every 48 000 miles (80 000 km)

- Renew the timing belt (Section 39).

## Every 60 000 miles (100 000 km) or 5 years, whichever occurs first

- Renew the braking system rubber seals (recommendation only) (Section 40).
- Check the operation of the emission control equipment (Section 41).

## Engine compartment component locations - 4-cylinder engine models with single-point fuel injection

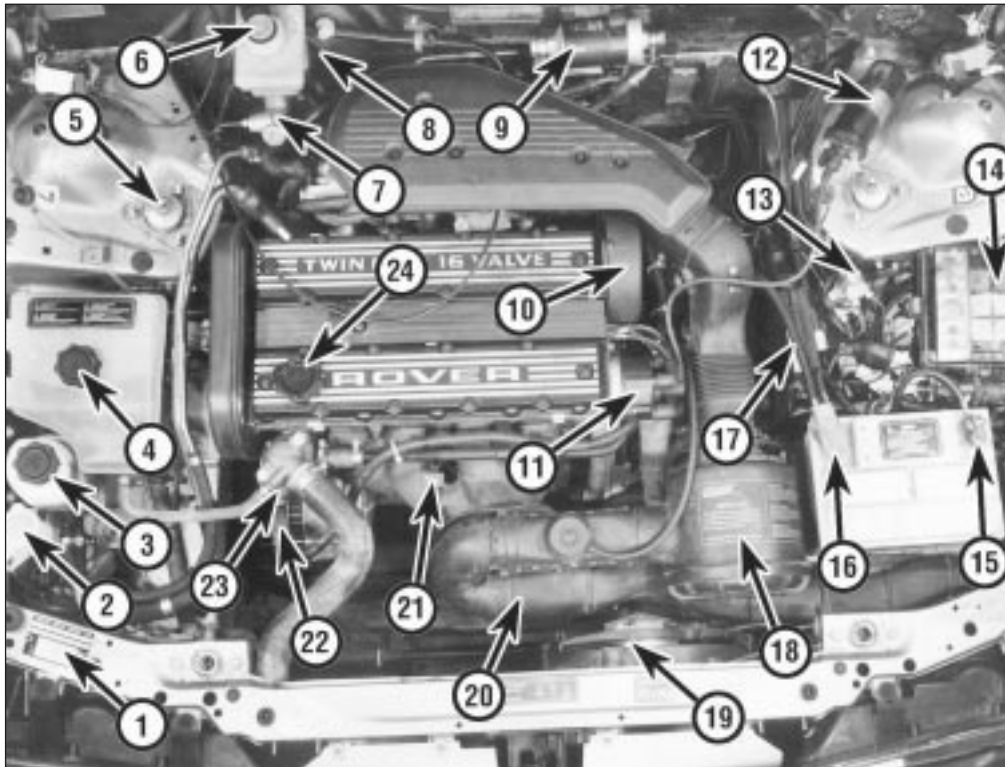

- 1 Vehicle identification plate
- 2 Screen washer reservoir filler
- 3 Power steering fluid reservoir filler
- 4 Cooling system expansion tank filler
- 5 Front shock absorber top mounting
- 6 Brake and clutch fluid reservoir filler
- 7 Brake master cylinder
- 8 Vacuum servo unit
- 9 Fuel filter
- 10 Power steering pump drivebelt (early models)
- 11 Distributor cap
- 12 Ignition coil
- 13 Brake pressure reducing valve
- 14 Fuse and relay box
- 15 Battery negative terminal
- 16 Battery positive terminal
- 17 Ignition/fuel ECU
- 18 Air cleaner assembly
- 19 Radiator cooling fan
- 20 Air cleaner intake trunking
- 21 Engine oil dipstick
- 22 Alternator
- 23 Thermostat housing
- 24 Engine oil filler cap

## 1.6 Maintenance and servicing

### Engine compartment component locations - 4-cylinder engine models with multi-point fuel injection

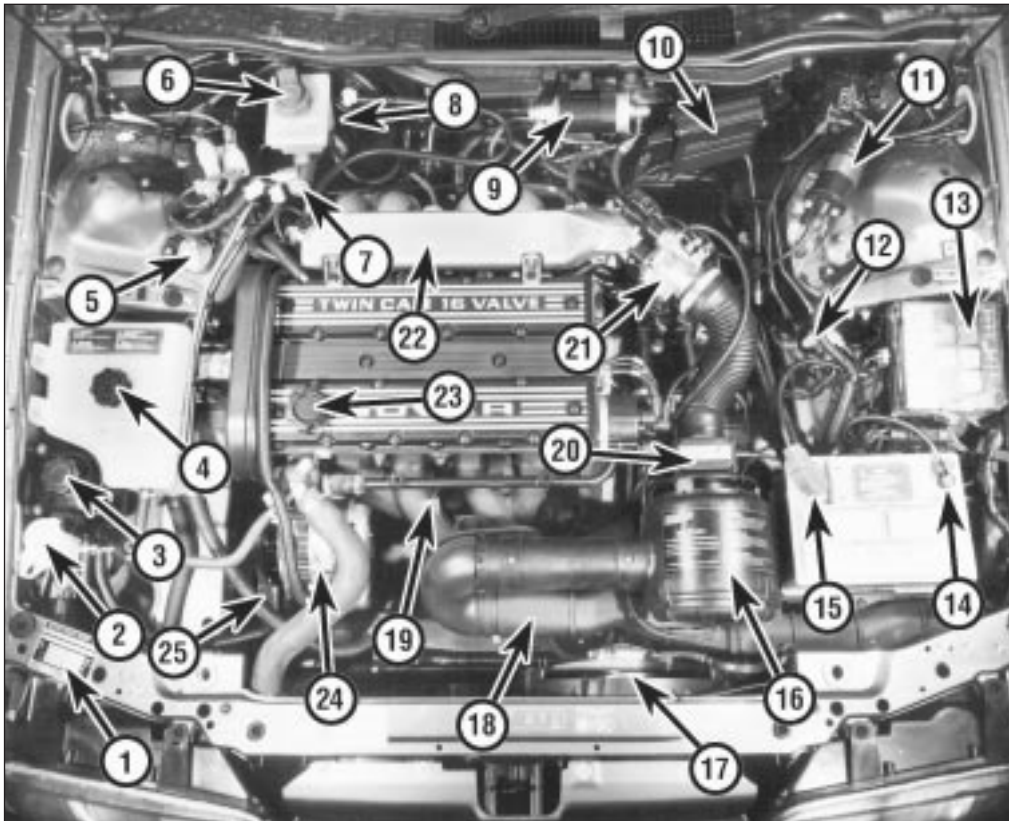

- 1 Vehicle identification plate
- 2 Screen washer reservoir filler
- 3 Power steering fluid reservoir filler
- 4 Cooling system expansion tank filler
- 5 Front shock absorber top mounting
- 6 Brake and clutch fluid reservoir filler
- 7 Brake master cylinder
- 8 Vacuum servo unit
- 9 Fuel filter
- 10 Ignition system ECU
- 11 Ignition coil
- 12 Brake pressure reducing valve
- 13 Fuse and relay box
- 14 Battery negative terminal
- 15 Battery positive terminal
- 16 Air cleaner assembly
- 17 Radiator cooling fan
- 18 Air cleaner intake trunking
- 19 Engine oil dipstick
- 20 Airflow meter
- 21 Throttle housing
- 22 Plenum chamber
- 23 Engine oil filler cap
- 24 Alternator
- 25 Power steering pump (later models)

### Engine compartment component locations - V6 engine models

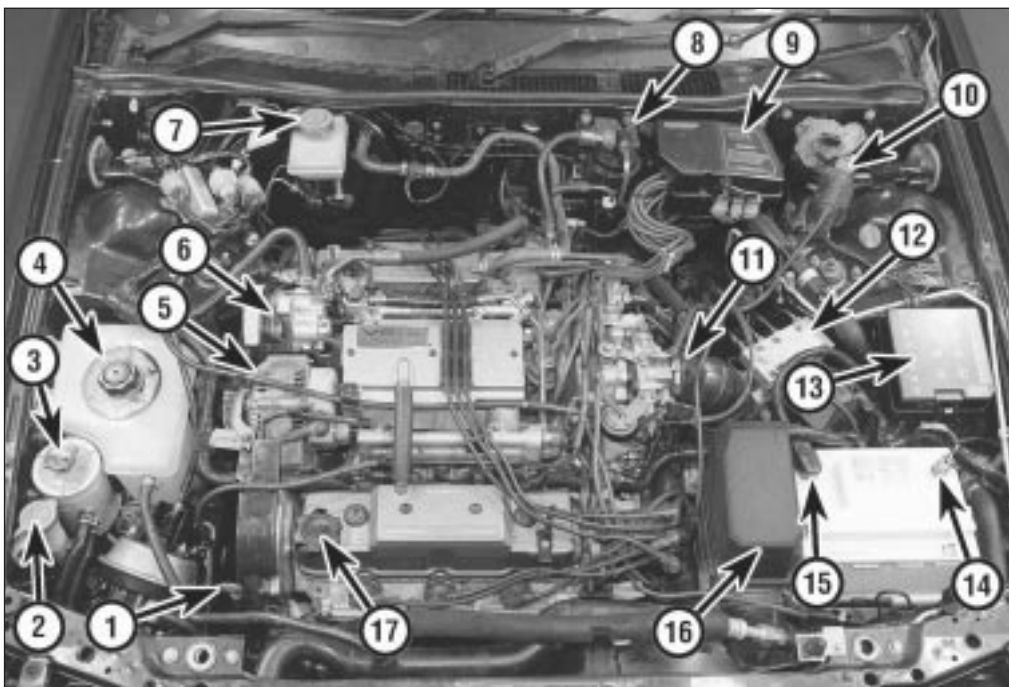

- 1 Engine oil dipstick
- 2 Screen washer reservoir filler
- 3 Power steering fluid reservoir filler
- 4 Cooling system expansion tank filler
- 5 Alternator
- 6 Power steering pump
- 7 Brake and clutch fluid reservoir filler
- 8 Fuel filter
- 9 Control box
- 10 Ignition coil
- 11 Throttle body
- 12 ABS modulator
- 13 Fuse and relay box
- 14 Battery negative terminal
- 15 Battery positive terminal
- 16 Air cleaner assembly
- 17 Engine oil filler cap



Underside view at front end showing component locations on 4-cylinder engine models

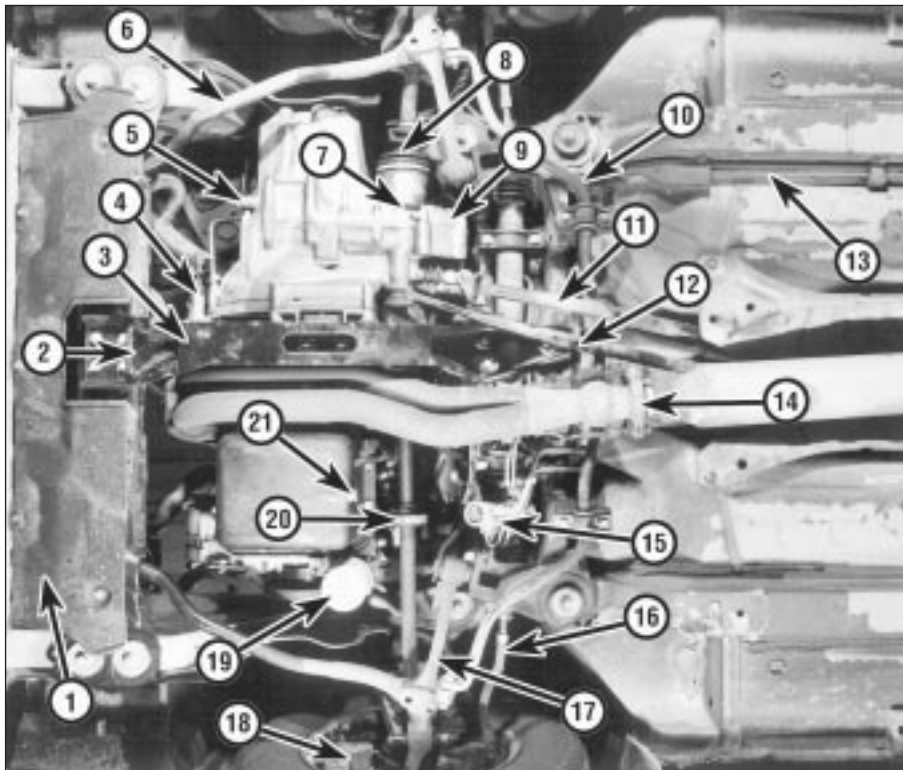

- 1 Engine undertray
- 2 Front towing eye
- 3 Longitudinal support member
- 4 Clutch slave cylinder
- 5 Reversing light switch
- 6 Front tie-bar
- 7 Transmission drain plug
- 8 Inner constant velocity joint
- 9 Transmission filler plug
- 10 Front anti-roll bar
- 11 Gearchange rod
- 12 Steady rod
- 13 Fuel pipes
- 14 Exhaust section flange joint
- 15 Power steering gear
- 16 Steering track rod
- 17 Front lower suspension arm
- 18 Brake caliper
- 19 Oil filter
- 20 Driveshaft damper
- 21 Engine oil drain plug

Underside view at rear end

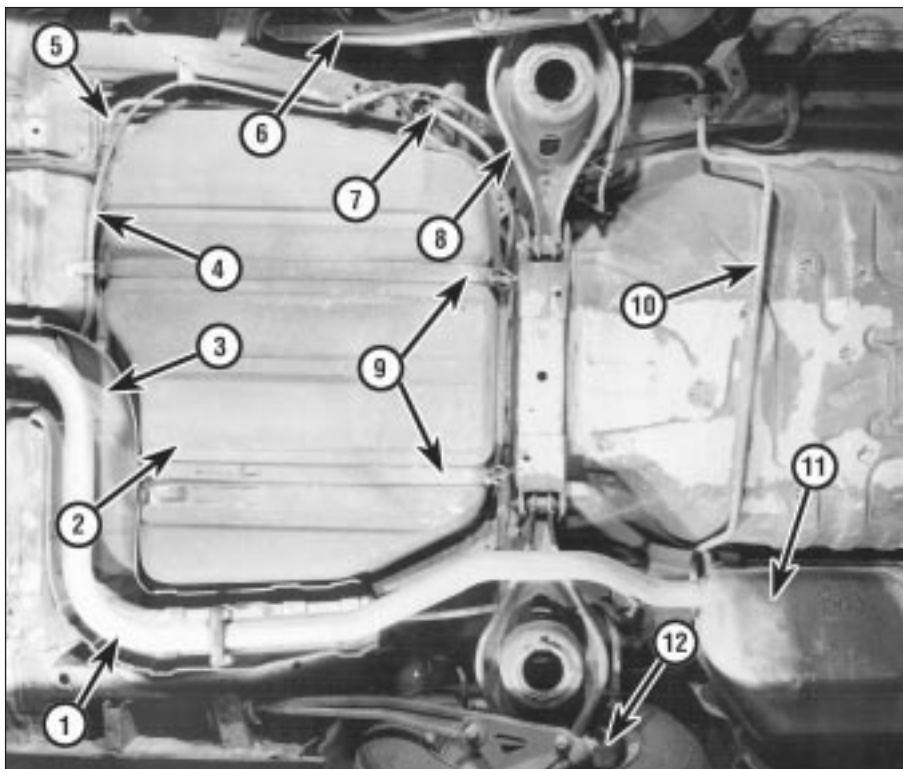

- 1 Exhaust intermediate section
- 2 Fuel tank
- 3 Exhaust rear heat shield
- 4 Handbrake cable
- 5 Fuel pipes
- 6 Trailing link
- 7 Fuel filler neck connection
- 8 Transverse link
- 9 Fuel tank retaining straps
- 10 Rear anti-roll bar
- 11 Rear silencer
- 12 Brake caliper

# 1.8 Maintenance and servicing

## Maintenance procedures

### 1 Introduction

This Chapter is designed to help the home mechanic maintain the Rover 800 Series models for peak performance, economy, safety and long life.

Contained in this Chapter is a master maintenance schedule, followed by Sections dealing specifically with each item on the schedule. Visual checks, adjustments, component replacement and other helpful items are included. Refer to the accompanying illustrations of the engine compartment and the underside of the vehicle for the location of various components.

Servicing your Rover in accordance with the mileage/time maintenance schedule and the following Sections will provide it with a

planned maintenance programme, which should result in a long and reliable service life. This is a comprehensive plan, so maintaining some items but not others at the specified service intervals will not produce the same results.

As you service your car, you will discover that many of the procedures can - and should - be grouped together, because of the nature of the particular procedure you're performing, or because of the close proximity to one another of two otherwise-unrelated components.

For example, if the vehicle is raised for any reason, you should inspect the exhaust, suspension, steering and fuel systems while you're under the vehicle. When you're checking the tyres, it makes good sense to check the brakes and wheel bearings, especially if the roadwheels have already been removed.

Finally, let's suppose you have to borrow or

hire a torque wrench. Even if you only need to tighten the spark plugs, you might as well check the torque of as many critical fasteners as time allows.

### 2 Routine maintenance

The first step of this maintenance programme is to prepare yourself before the actual work begins. Read through all the Sections which are relevant to the procedures you're planning to carry out, then make a list of, and gather together, all the parts and tools you will need to do the job. If it looks as if you might run into problems during a particular segment of some procedure, seek advice from your local parts man or dealer service department.

## Weekly checks

### 3 Fluid level checks



#### General

1 Fluids are an essential part of the lubrication, cooling, braking and other systems. Because these fluids gradually become depleted and/or contaminated during normal operation of the vehicle, they must be periodically replenished. See "Lubricants, fluids and capacities" at the beginning of this Chapter before adding fluid to any of the following components. **Note:** *The vehicle must be on level ground before fluid levels can be checked.*

#### Engine oil

2 The engine oil level is checked with a dipstick located at the front of the engine in the centre, or on the right-hand side (see illustration). The dipstick extends through a metal tube, from which it protrudes down into the sump at the bottom of the engine.

3 The oil level should be checked before the vehicle is driven, or about 5 minutes after the engine has been switched off. If the level is checked immediately after driving the vehicle, some of the oil will remain in the engine upper components, producing an inaccurate reading.

4 Pull the dipstick from the tube, and wipe all the oil from the end with a clean rag or paper towel; note the dipstick's maximum and minimum levels, indicated by holes on the dipstick (see illustration). Insert the clean dipstick all the way back into its metal tube,

and pull it out again. Observe the oil on the end of the dipstick; its level should be between these two holes.

5 Do not allow the level to drop below the minimum level notch, or oil starvation may cause engine damage. Conversely, overfilling

the engine (adding oil above the maximum level notch) may cause oil-fouled spark plugs, oil leaks or oil seal failures.

6 The oil filler cap is screwed into the right-hand front end of the valve cover; unscrew it to add oil (see illustrations). When topping-



3.2 Engine oil dipstick location (arrowed) on V6 engines

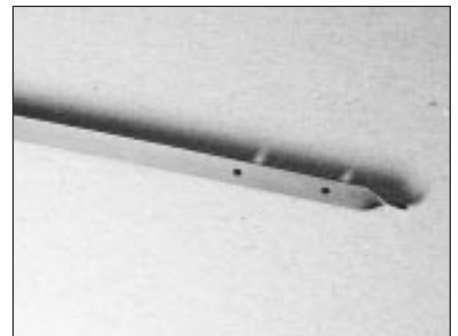

3.4 Note the dipstick's maximum and minimum levels, indicated by holes on the dipstick



3.6a Topping up the engine oil on 4-cylinder engines . . .



3.6b . . . and on V6 engines

up, use only the correct grade and type of oil, as given in the "Lubricants, fluids and capacities" Section of this Chapter; use a funnel if necessary to prevent spills. After adding the oil, refit the filler cap hand-tight. Start the engine, and allow it to idle while the oil is redistributed around the engine - while you are waiting, look carefully for any oil leaks, particularly around the oil filter or drain plug. Stop the engine; check the oil level again, after the oil has had enough time to drain from the upper block and cylinder head galleries.

7 Checking the oil level is an important preventive maintenance step. A continually-dropping oil level indicates oil leakage through damaged seals and from loose connections, or oil consumption past worn piston rings or valve guides. If the oil looks milky in colour, or has water droplets in it, the cylinder head gasket may be blown - the engine's compression pressure should be checked immediately (see Chapter 2). The condition of the oil should also be checked. Each time you check the oil level, slide your thumb and index finger up the dipstick before wiping off the oil. If you see small dirt or metal particles clinging to the dipstick, the oil should be changed.

## Coolant



**Warning: DO NOT attempt to remove the expansion tank filler cap, or to disturb any part of the cooling system, while it or the engine is hot, as there is a very great risk of scalding.**

8 All vehicles covered by this manual are equipped with a sealed, pressurised cooling system. A translucent plastic expansion tank, located on the right-hand side of the engine compartment, is connected by a hose to the thermostat housing or radiator top hose. As the coolant heats up during engine operation, surplus coolant passes through the connecting hose into the expansion tank. As the engine cools, the coolant is automatically drawn back into the cooling system's main components, to maintain the correct level.

9 While the coolant level must be checked regularly, remember that it will vary with the temperature of the engine. When the engine is cold, the level should be up to the pipe outlet on the side of the tank, but once the engine has warmed up, the level may rise to above this level.

10 For an accurate check of the coolant level, the engine must be cold and the level must be up to the pipe outlet. If it is below this level, the coolant must be topped-up as follows.

11 First prepare a sufficient quantity of coolant mixture, using clean, soft water and antifreeze of the recommended type, in the specified mixture ratio. If only a small amount of coolant is required to bring the system up to the proper level, plain water can be used, but repeatedly doing this will dilute the antifreeze/water solution in the system, reducing the protection it should provide against freezing and corrosion. To maintain

the specified antifreeze/water ratio, it is essential to top-up the coolant level with the correct mixture, as described here. Use only ethylene/glycol type antifreeze, and *do not* use supplementary inhibitors or additives.



**Warning: Never remove the expansion tank filler cap when the engine is running, or has just been switched off, as the cooling system will be hot, and the consequent escaping steam and scalding coolant could cause serious injury.**

12 If topping-up is necessary, wait until the system has cooled completely (or at least 10 minutes after switching off the engine, if lack of time means it is absolutely necessary to top-up while the engine may still be warm). Wrap a thick cloth around the expansion tank filler cap, and unscrew it one full turn. If any hissing is heard as steam escapes, wait until the hissing ceases, indicating that pressure is released, then slowly unscrew the filler cap until it can be removed. If more hissing sounds are heard, wait until they have stopped before unscrewing the filler cap completely. At all times, keep your face, hands and other exposed skin well away from the filler opening.

13 When the filler cap has been removed, add coolant to bring the level up to the outlet pipe level (see illustration). Refit the cap, tightening it securely.

14 With this type of cooling system, the addition of coolant should only be necessary at very infrequent intervals. If topping-up is regularly required, or if the coolant level drops within a short time after replenishment, there may be a leak in the system.

15 Inspect the radiator, hoses, expansion tank filler cap, radiator drain plug and water pump. If no leak is evident, have the filler cap and the entire system pressure-tested by your dealer or garage; this will usually show up a small leak not otherwise visible.

## Windscreen/tailgate and headlight washer fluid

16 Fluid for the windscreen/tailgate/headlight washer system is stored in a plastic reservoir, the filler neck of which is located at the right-hand front corner of the engine compartment.

17 To check the fluid level, release the cap and observe the level in the reservoir by looking down the filler neck. In milder

climates, plain water can be used to top-up the reservoir, but the reservoir should be kept no more than two-thirds full, to allow for expansion should the water freeze. In colder climates, the use of a specially-formulated windscreen washer fluid, available at your dealer or any car accessory shop, will help lower the freezing point of the fluid. *Do not* use regular (engine) antifreeze - it will damage the vehicle's paintwork.

## Battery electrolyte

18 On models not equipped with a sealed battery (see Section 9), check the electrolyte level of all six battery cells. The level must be approximately 10 mm above the plates; this may be shown by maximum and minimum level lines marked on the battery's casing. If the level is low, use a coin to release the filler/vent cap, and add distilled water. Install and retighten the cap.

**Caution: Overfilling the cells may cause electrolyte to spill over during periods of heavy charging, causing corrosion or damage. Refer to the warning at the beginning of Section 9.**

## Brake fluid

19 The brake fluid reservoir is located on the top of the brake master cylinder, attached to the front of the vacuum servo unit. The "MAX" and "MIN" marks are indicated on the side of the translucent reservoir, and the fluid level should be maintained between these marks at all times.

20 The brake fluid inside the reservoir is readily visible. With the vehicle on level ground, the level should be on or just below the "MAX" mark.

21 Progressive wear of the brake pad linings causes the level of the brake fluid to gradually fall; however, when the brake pads are renewed, the original level of the fluid is restored. It is not therefore necessary to top-up the level to compensate for this minimal drop, but the level must never be allowed to fall below the minimum mark.

22 If topping-up is necessary, first wipe the area around the filler cap with a clean rag before removing the cap - do not invert the cap after removal. When adding fluid, pour it carefully into the reservoir, to avoid spilling it on surrounding painted surfaces (see illustration).



3.13 Topping up the cooling system



3.22 Topping up the brake master cylinder reservoir





4.2 Checking the tyre tread depth with a depth gauge

Be sure to use only the specified hydraulic fluid (see "Lubricants, fluids and capacities" at the start of this Chapter) since mixing different types of fluid can cause damage to the system.



**Warning: Brake hydraulic fluid can harm your eyes and damage painted surfaces, so use extreme caution when handling and pouring it. Wash off spills immediately with plenty of water. Do not use fluid that has been standing open for some time, as it absorbs moisture from the air. Excess moisture can cause corrosion and a dangerous loss of braking effectiveness.**

**23** When adding fluid, it is a good idea to inspect the reservoir for contamination. The system should be drained and refilled if deposits, dirt particles or contamination are seen in the fluid.

**24** After filling the reservoir to the correct level, make sure that the cap is refitted

securely, to avoid leaks and the entry of foreign matter.

**25** If the reservoir requires repeated replenishing to maintain the correct level, this is an indication of an hydraulic leak somewhere in the system, which should be investigated immediately.

### Power steering fluid

**26** See Section 5 of this Chapter.

## 4 Tyre and tyre pressure checks

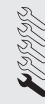

**1** Periodic inspection of the tyres may spare you from the inconvenience of being stranded with a flat tyre. It can also provide you with vital information regarding possible problems in the steering and suspension systems before major damage occurs.

**2** The current tyres are equipped with tread wear indicator (TWI) bands, which will appear when the tread depth reaches approximately 1.6 mm. Most tyres have a mark around the tyre at regular intervals to indicate the location of the tread wear indicators, the mark being TWI, an arrow, or the tyre manufacturer's symbol. Tread wear can also be monitored with a simple inexpensive device known as a tread depth indicator gauge (see illustration).

**3** Ensure that tyre pressures are checked regularly and maintained correctly (see the Specifications at the beginning of this Chapter for pressures). Checking should be carried out with the tyres cold, and *not* immediately after

the vehicle has been in use. If the pressures are checked with the tyres hot, an apparently-high reading will be obtained, owing to heat expansion. *Under no circumstances* should an attempt be made to reduce the pressures to the quoted cold reading in this instance, or effective under-inflation will result. Most garage forecourts have a pressure line which combines a gauge to check and adjust the tyre pressures, but they may vary in accuracy, due to general misuse and abuse. It therefore pays to carry a good-quality tyre pressure gauge in the vehicle, to make the checks required and ensure pressure accuracy.

**4** Note any abnormal tread wear (see illustration). Tread pattern irregularities such as feathering, flat spots, and more wear on one side than the other, are indications of front wheel alignment and/or balance problems. If any of these conditions are noted, they should be rectified as soon as possible.

**5** Under-inflation will cause overheating of the tyre, owing to excessive flexing of the casing, and the tread will not sit correctly on the road surface. This will cause a consequent loss of adhesion and excessive wear, as well as the danger of sudden tyre failure due to heat build-up.

**6** Over-inflation will cause rapid wear of the centre part of the tyre tread, coupled with reduced adhesion, harder ride, and the danger of damage occurring in the tyre casing.

**7** Regularly check the tyres for damage in the form of cuts or bulges, especially in the sidewalls. Remove any nails or stones

## Tyre tread wear patterns



### Shoulder Wear

#### Underinflation (wear on both sides)

Under-inflation will cause overheating of the tyre, because the tyre will flex too much, and the tread will not sit correctly on the road surface. This will cause a loss of grip and excessive wear, not to mention the danger of sudden tyre failure due to heat build-up.

*Check and adjust pressures*

#### Incorrect wheel camber (wear on one side)

*Repair or renew suspension parts*

#### Hard cornering

*Reduce speed!*



### Centre Wear

#### Overinflation

Over-inflation will cause rapid wear of the centre part of the tyre tread, coupled with reduced grip, harsher ride, and the danger of shock damage occurring in the tyre casing.

*Check and adjust pressures*

*If you sometimes have to inflate your car's tyres to the higher pressures specified for maximum load or sustained high speed, don't forget to reduce the pressures to normal afterwards.*



### Uneven Wear

Front tyres may wear unevenly as a result of wheel misalignment. Most tyre dealers and garages can check and adjust the wheel alignment (or "tracking") for a modest charge.

#### Incorrect camber or castor

*Repair or renew suspension parts*

#### Malfunctioning suspension

*Repair or renew suspension parts*

#### Unbalanced wheel

*Balance tyres*

#### Incorrect toe setting

*Adjust front wheel alignment*

**Note:** *The feathered edge of the tread which typifies toe wear is best checked by feel.*

embedded in the tread, before they penetrate the tyre to cause deflation. If removal of a nail reveals that the tyre has been punctured, refit the nail, so that its point of penetration is marked. Then immediately change the wheel, and have the tyre repaired by a tyre dealer. Do not drive on a tyre in such a condition. If in any doubt as to the possible consequences of any damage found, consult your local tyre dealer for advice.

**8** General tyre wear is influenced to a large degree by driving style - harsh braking and acceleration, or fast cornering, will all produce more rapid tyre wear. Interchanging of tyres may result in more even wear; however, it is worth bearing in mind that if this is completely effective, the added expense is incurred of replacing simultaneously a complete set of tyres, which may prove financially restrictive for many owners.

**9** Front tyres may wear unevenly as a result of wheel misalignment. The front wheels should always be correctly aligned according to the settings specified by the vehicle manufacturer.

**10** Don't forget to check the spare tyre for condition and pressure.

**11** Legal restrictions apply to many aspects of tyre fitting and usage, and in the UK this information is contained in the Motor Vehicle Construction and Use Regulations. It is suggested that a copy of these regulations is obtained from your local police, if in doubt as to current legal requirements with regard to tyre type and condition, minimum tread depth, etc.

## 5 Power steering fluid level check



**1** The power steering fluid reservoir is located on the right-hand side of the engine compartment next to the cooling system expansion tank.

**2** For the fluid level check on 4-cylinder models, the power steering system must be cold; on V6 models, it may be either hot or cold.



**5.5** Topping up the power steering fluid reservoir

**3** Use a clean rag to wipe the filler cap and the surrounding area, to prevent foreign matter from entering the system. Unscrew and remove the filler cap.

**4** Check that the fluid level is up to the "MAX" mark on the dipstick. On V6 engine models, there is a scale on both sides of the dipstick, one for hot checking and one for cold checking.

**5** Top-up the level to the "MAX" mark, using the grade of fluid specified at the beginning of this Chapter (see illustration). Be careful not to introduce dirt into the system, and do not overfill. The need for frequent topping-up indicates a leak, which should be investigated.

**6** Refit the filler cap.

## 6 Windscreen/tailgate and headlight washer system and wiper blade check



**1** The windscreen and tailgate wiper and blade assembly should be inspected at the specified intervals for damage, loose components, and cracked or worn blade elements.

**2** Road film can build up on the wiper blades and affect their efficiency, so they should be washed regularly with a mild detergent solution.

**3** The action of the wiping mechanism can loosen bolts, nuts and fasteners, so they

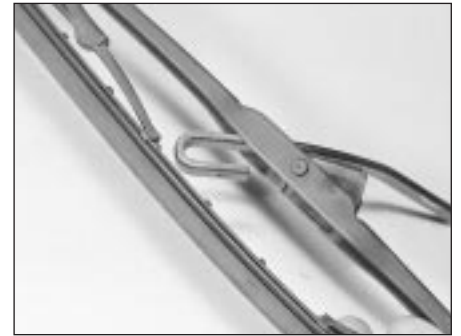

**6.6** Remove the windscreen wiper blade by depressing the catch on the blade, then withdraw the blade assembly off the arm

should be checked and tightened, as necessary, at the same time as the wiper blades are checked.

**4** If the wiper blade elements are cracked, worn or warped, or no longer clean adequately, they should be replaced with new ones.

**5** Switch on the ignition, and the windscreen wipers, then park the wipers vertically on the windscreen while they are still running. Lift the wiper arm and blade away from the glass.

**6** To remove the wiper blade, depress the catch on the blade attachment, then withdraw the blade assembly off the arm (see illustration).

**7** The tailgate wiper blade is removed in the same way, but it is not necessary to park it in the centre of the glass prior to removal.

**8** If the metal part of the wiper blade is in good condition, it may be possible to renew the rubber insert separately. The insert can be obtained from a car accessory shop and, according to type, it may need to be cut to the correct length before sliding into the clips.

**9** Refit the wiper blade assembly using a reversal of the removal procedure, making sure that it fully engages with the spring clip.

**10** Check that the washer jets direct the fluid onto the upper part of the windscreen/tailgate, and if necessary adjust the small sphere on the jet with a pin. Note that the headlight washer jets are of the fixed type and cannot be adjusted.

## Every 6000 miles or 6 months, whichever occurs first

### 7 Engine oil and filter change



**Frequent oil changes are the best preventive maintenance the home mechanic can give the engine, because ageing oil becomes diluted and contaminated, which leads to premature engine wear.**

**1** Make sure that you have all the necessary tools before you begin this procedure. You should also have plenty of rags or newspapers handy, for mopping up any spills.

**2** To avoid any possibility of scalding, and to protect yourself from possible skin irritants and other harmful contaminants in used engine oils, it is advisable to wear gloves when carrying out this work.

**3** Access to the underside of the vehicle is greatly improved if the vehicle can be lifted on a hoist, driven onto ramps, or supported by axle stands.



**Warning: Do not work under a vehicle which is supported only by an hydraulic or scissor-type jack, or by bricks, blocks of wood, etc.**

**4** If this is your first oil change, get under the vehicle and familiarise yourself with the position of the engine oil drain plug location in the sump. The engine and exhaust components will be warm during the actual work, so try to anticipate any potential problems while the engine and accessories are cool.

**5** The oil should preferably be changed when



# 1•12 Every 6000 miles



**7.9 Using a filter removal tool, unscrew the oil filter from the housing**

the engine is still at normal operating temperature, just after a run; warm oil and sludge will flow out more easily. Park the vehicle on firm, level ground, apply the handbrake, then select 1st or reverse gear (manual transmission) or the "P" position (automatics). Open the bonnet and remove the engine oil filler cap from the valve cover, then remove the oil level dipstick.

**6** Raise the front of the vehicle, and support it securely on axle stands. Remove the front right-hand roadwheel, then remove the plastic panel under the wheelarch to provide additional access to the oil filter.



**Warning:** To avoid personal injury, never get beneath the vehicle when it is supported by only by a jack. The jack provided

with your vehicle is designed solely for raising the vehicle to remove and refit the roadwheels. Always use axle stands to support the vehicle when it becomes necessary to place your body underneath the vehicle.

**7** Being careful not to touch the hot exhaust components, place the drain pan under the drain plug, and unscrew the plug. If possible, try to keep the plug pressed into the sump while unscrewing it by hand the last couple of turns. As the plug releases from the threads, move it away sharply, so the stream of oil issuing from the sump runs into the pan, not up your sleeve! Allow the oil to drain into the drain pan, and check the condition of the plug's sealing washer; renew it if worn or damaged.

**8** Allow some time for the old oil to drain, noting that it may be necessary to reposition the pan as the oil flow slows to a trickle. When the oil has completely drained, wipe clean the drain plug and its threads in the sump and refit the plug, tightening it securely.

**9** On all engines except the 2.5 litre V6, the oil filter renewal procedure is relatively simple; proceed as follows. Reposition the drain pan under the oil filter then, using a filter removal tool, unscrew the oil filter from the housing; be prepared for some oil spillage (see illustration). Check the old filter to make sure that the rubber sealing ring hasn't stuck to the engine; if it has, carefully remove it. Withdraw

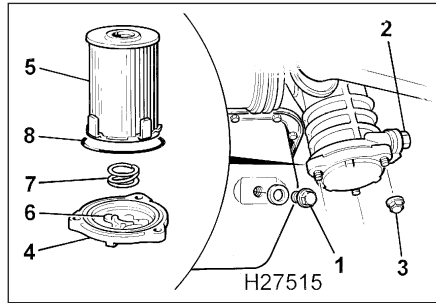

**7.12 Oil filter cartridge components on 2.5 litre V6 engines**

- 1 Engine oil drain plug
- 2 Oil filter housing drain plug
- 3 Baseplate retaining nuts
- 4 Baseplate
- 5 Oil filter cartridge
- 6 Spring locating lugs
- 7 Spring
- 8 Sealing ring

the filter, taking care to spill as little oil as possible.

**10** Using a clean, lint-free rag, wipe clean the cylinder block around the filter mounting. If there are no specific instructions supplied with it, fit a new oil filter as follows. Apply a light coating of clean engine oil to the filter's sealing ring. Screw the filter into position on the engine until it seats, then tighten it through a further half- to three-quarters of a turn *only*. Tighten the filter by hand only - do not use any tools.

**11** On 2.5 litre V6 engines the filter is a cartridge contained within the filter housing.

**12** Reposition the drain pan under the filter assembly and first, drain the filter by unscrewing the drain plug on the side of the housing (see illustration). Refit the plug when the filter has drained. Now undo the three retaining nuts and withdraw the baseplate from the filter assembly. As you do this be prepared for oil spillage and catch the filter cartridge and its components, which will fall out and probably land in the oil as the baseplate is removed. Retrieve the filter lower spring and the sealing ring on the baseplate.

**13** Clean the baseplate thoroughly and wipe around the inside of the filter housing using a clean lint-free rag.

**14** Locate the new sealing ring in the baseplate, then fit the spring to the locating lugs in the baseplate. Locate the filter in the housing, and refit the baseplate. Screw on the three nuts and tighten them securely.

**15** Remove the old oil and all tools from under the vehicle, refit the access panel and roadwheel, then lower the vehicle to the ground.

**16** Refill the engine with oil, using the correct grade and type of oil, as given in the "Lubricants, fluids and capacities" Section of this Chapter. Pour in half the specified quantity of oil first, then wait a few minutes for the oil to fall to the sump. Continue adding oil a small quantity at a time, until the level is up

to the lower notch on the dipstick. Adding approximately 0.5 to 1.0 litre will raise the level to the dipstick's upper notch.

**17** Start the engine. The oil pressure warning light will take a few seconds to go out while the new filter fills with oil; do not race the engine while the light is on. Run the engine for a few minutes, while checking for leaks around the oil filter seal and the drain plug.

**18** Switch off the engine, and wait a few minutes for the oil to settle in the sump once more. With the new oil circulated and the filter now completely full, recheck the level on the dipstick, adding more oil as necessary.

**19** Dispose of the used engine oil safely, with reference to "General repair procedures" in the Reference Section of this manual.

## 8 Underbonnet check for fluid leaks and hose condition



**Caution:** Renewal of air conditioning hoses must be left to a dealer service

department or air conditioning specialist who has the equipment to depressurise the system safely. Never remove air conditioning components or hoses until the system has been depressurised.

### General

**1** High temperatures in the engine compartment can cause the deterioration of the rubber and plastic hoses used for engine, accessory and emission systems operation. Periodic inspection should be made for cracks, loose clamps, material hardening and leaks.

**2** Carefully check the large top and bottom radiator hoses, along with the other smaller-diameter cooling system hoses and metal pipes; do not forget the heater hoses/pipes which run from the engine to the bulkhead. Inspect each hose along its entire length, replacing any that is cracked, swollen or shows signs of deterioration. Cracks may become more apparent if the hose is squeezed.

**3** Make sure that all hose connections are tight. A leak in the cooling system will usually show up as white- or rust-coloured deposits on the areas adjoining the leak; if the spring clamps that are used to secure the hoses in this system appear to be slackening, they should be renewed to prevent the possibility of leaks.

**4** Some other hoses are secured to their fittings with clamps. Where clamps are used, check that they haven't lost their tension, allowing the hose to leak. If clamps aren't used, make sure the hose has not expanded and/or hardened where it slips over the fitting, allowing it to leak.

**5** Check all fluid reservoirs, filler caps, drain plugs and fittings etc, looking for any signs of leakage of oil, transmission and/or brake hydraulic fluid, coolant and power steering

fluid. If the vehicle is regularly parked in the same place, close inspection of the ground underneath it will soon show any leaks; ignore the puddle of water which will be left if the air conditioning system is in use. As soon as a leak is detected, its source must be traced and rectified. Where oil has been leaking for some time, it is usually necessary to use a steam cleaner, pressure washer or similar, to clean away the accumulated dirt, so that the exact source of the leak can be identified.

## Vacuum hoses

6 It's quite common for vacuum hoses, especially those in the emissions system, to be numbered or colour-coded, or to be identified by coloured stripes moulded into them. Various systems require hoses with different wall thicknesses, collapse resistance and temperature resistance. When renewing hoses, be sure the new ones are made of the same material.

7 Often the only effective way to check a hose is to remove it completely from the vehicle. If more than one hose is removed, be sure to label the hoses and fittings to ensure correct installation.

8 When checking vacuum hoses, be sure to include any plastic T-fittings in the check. Inspect the fittings for cracks, and check the hose where it fits over the fitting

for distortion, which could cause leakage. 9 A small piece of vacuum hose (quarter-inch inside diameter) can be used as a stethoscope to detect vacuum leaks. Hold one end of the hose to your ear, and probe around vacuum hoses and fittings, listening for the "hissing" sound characteristic of a vacuum leak.



**Warning:** When probing with the vacuum hose stethoscope, be very careful not to come into contact with moving engine

components such as the auxiliary drivebelt, radiator electric cooling fan, etc.

## Fuel hoses



**Warning:** There are certain precautions which must be taken when inspecting or servicing fuel system

components. Work in a well-ventilated area, and do not allow open flames (cigarettes, appliance pilot lights, etc.) or bare light bulbs near the work area. Mop up any spills immediately, and do not store fuel-soaked rags where they could ignite.

10 Check all fuel hoses for deterioration and chafing. Check especially for cracks in areas where the hose bends, and also just before fittings, such as where a hose attaches to the fuel filter.

11 High-quality fuel line, usually identified by the word "Fluoroelastomer" printed on the hose, should be used for fuel line renewal. Never, under any circumstances, use unreinforced vacuum line, clear plastic tubing or water hose for fuel lines.

12 Spring-type clamps are commonly used on fuel lines. These clamps often lose their tension over a period of time, and can be "sprung" during removal. Replace all spring-type clamps with screw clamps whenever a hose is replaced.

## Metal lines

13 Sections of metal piping are often used for fuel line between the fuel filter and the engine. Check carefully to be sure the piping has not been bent or crimped, and that cracks have not started in the line.

14 If a section of metal fuel line must be renewed, only seamless steel piping should be used, since copper and aluminium piping don't have the strength necessary to withstand normal engine vibration.

15 Check the metal brake lines where they enter the master cylinder and ABS hydraulic unit (if used) for cracks in the lines or loose fittings. Any sign of brake fluid leakage calls for an immediate and thorough inspection of the brake system.

# Every 12 000 miles or 12 months, whichever occurs first

## 9 Cooling system check



1 The engine should be cold for the cooling system checks, so perform the following procedure before driving the vehicle, or after it has been shut off for at least three hours.

2 Remove the expansion tank filler cap (Section 3), and clean it thoroughly inside and out with a rag. Clean the filler neck on the expansion tank. The presence of rust or corrosion in the filler neck indicates that the coolant should be changed. The coolant inside the expansion tank should be relatively clean and transparent. If it is rust-coloured, drain and flush the system, and refill with a fresh coolant mixture.

3 Carefully check the radiator hoses and heater hoses as described in Section 8.

4 Inspect all other cooling system components (joint faces, etc.) for leaks. A leak in the cooling system will usually show up as white- or rust-coloured deposits on the area adjoining the leak. Where any problems of this nature are found on system components, renew the component or gasket with reference to Chapter 3.

5 Clean the front of the radiator with a soft brush to remove all insects, leaves, etc, embedded in the radiator fins. Be careful not

to damage the radiator fins, or cut your fingers on them.

## 10 Accelerator cable and linkage check and lubrication



1 From within the engine compartment check the condition of the accelerator cable ensuring that it isn't kinked or trapped behind any other components or fittings. Make sure that all clips and cable ties are in place and that the cable properly supported. Where cruise control is fitted, check the cruise control operating cable in the same way.

2 Operate the throttle by means of the accelerator pedal and make sure that the action is smooth without notchiness or evidence of binding.

3 Finally, lubricate the throttle linkage and the accelerator pedal pivot with a few drops of light oil.

## 11 Spark plug renewal



**Note:** Spark plug renewal at this service interval is only necessary on certain engines without emission control equipment. On all

other engines the recommended interval for spark plug renewal is every 24 000 miles or 2 years. Consult the spark plug manufacturer or a Rover dealer for their advice concerning renewal intervals.

## Spark plug check and renewal

1 It is vital for the correct running, full performance and proper economy of the engine that the spark plugs perform with maximum efficiency. The most important factor in ensuring this, is that the plugs fitted are appropriate for the engine. The suitable type is given in the Specifications Section at the beginning of this Chapter, or in the vehicle's Owner's Handbook. If this type is used and the engine is in good condition, the spark plugs should not need attention between scheduled renewal intervals. Spark plug cleaning is rarely necessary, and should not be attempted unless specialised equipment is available, as damage can easily be caused to the firing ends.

2 Spark plug removal and refitting requires a spark plug socket, with an extension which can be turned by a ratchet handle or similar. This socket is lined with a rubber sleeve, to protect the porcelain insulator of the spark plug, and to hold the plug while you insert it into the spark plug hole. You will also need a wire-type feeler gauge, to check and adjust the spark plug electrode gap, and a torque

# 1.14 Every 12 000 miles



**11.2 Tools required for spark plug removal, gap adjustment and refitting**

wrench to tighten the new plugs to the specified torque (see illustration).

**3** To remove the spark plugs, first open the bonnet; the plugs are easily reached at the top of the engine or on the front and rear facing sides. Note how the spark plug (HT) leads are routed and secured by clips, and on some engines, how they're positioned along the channel in the cylinder head cover. To prevent the possibility of mixing up spark plug (HT) leads, it is a good idea to work on one spark plug at a time.

**4** If the marks on the original-equipment spark plug (HT) leads cannot be seen, mark the leads 1 to 4 (or 1 to 6), to correspond to the cylinder the lead serves (No 1 cylinder is at the timing belt end of the engine on 4-cylinder engines, and at the timing belt end of the engine on the rear bank under the brake master cylinder on V6 engines).

**5** On 4-cylinder engines, undo the bolts securing the spark plug cover to the centre of the cylinder head, noting the accelerator cable support bracket on early engines. Lift off the cover and again, on early engines, release the HT lead grommet from the end of the cover.

**6** On all engines, pull the leads from the plugs by gripping the rubber boot, not the lead, otherwise the lead connection may be fractured.

**7** Unscrew the spark plugs, ensuring that the socket is kept in alignment with each plug - if the socket is forcibly moved to either side, the porcelain top of the plug may be broken off. If any undue difficulty is encountered when unscrewing any of the spark plugs, carefully

check the cylinder head threads and tapered sealing surfaces for signs of wear, excessive corrosion or damage; if any of these conditions is found, seek the advice of a dealer as to the best method of repair.

**8** As each plug is removed, examine it as follows - this will give a good indication of the condition of the engine. If the insulator nose of the spark plug is clean and white, with no deposits, this is indicative of a weak mixture.

**9** If the tip and insulator nose are covered with hard black-looking deposits, then this is indicative that the mixture is too rich. Should the plug be black and oily, then it is likely that the engine is fairly worn, as well as the mixture being too rich.

**10** If the insulator nose is covered with light tan to greyish-brown deposits, then the mixture is correct, and it is likely that the engine is in good condition.

**11** If you are renewing the spark plugs, purchase the new plugs, then check each of them first for faults such as cracked insulators or damaged threads. Note also that, whenever the spark plugs are renewed as a routine service operation, the spark plug (HT) leads should be checked as described below.

**12** The spark plug electrode gap is of considerable importance as, if it is too large or too small, the size of the spark and its efficiency will be seriously impaired. The gap should be set to the value given in the Specifications Section of this Chapter. New plugs will not necessarily be set to the correct gap, so they should always be checked before fitting.

**13** Special spark plug electrode gap adjusting tools are available from most motor accessory shops.

**14** To set the electrode gap, measure the gap with a feeler gauge or adjusting tool, and then bend open, or closed, the outer plug electrode until the correct gap is achieved (see illustrations). The centre electrode should never be bent, as this may crack the insulation and cause plug failure, if nothing worse. If the outer electrode is not exactly over the centre electrode, bend it gently to align them.

**15** Before fitting the spark plugs, check that the threaded connector sleeves at the top of the plugs are tight, and that the plug exterior surfaces and threads are

clean. Brown staining on the porcelain, immediately above the metal body, is quite normal, and does not necessarily indicate a leak between the body and insulator.

**16** On installing the spark plugs, first check that the cylinder head thread and sealing surface are as clean as possible; use a clean rag wrapped around a paintbrush to wipe clean the sealing surface. Apply a smear of copper-based grease or anti-seize compound to the threads of each plug, and screw them in by hand where possible.



*Take extra care to enter the plug threads correctly, as the cylinder head is of aluminium alloy - it's often difficult to insert spark plugs into their holes without cross-threading them. To avoid this possibility, fit a short piece of hose over the end of the spark plug. The flexible hose acts as a universal joint, to help align the plug with the plug hole. Should the plug begin to cross-thread, the hose will slip on the spark plug, preventing thread damage.*

**17** When each spark plug is started correctly on its threads, screw it down until it just seats lightly, then tighten it to the specified torque wrench setting.

**18** Reconnect the spark plug (HT) leads in their correct order, using a twisting motion on the boot until it is firmly seated. On 4-cylinder engines, refit the spark cover.

## **Spark plug (HT) lead and distributor cap check**

**19** The spark plug (HT) leads should be inspected one at a time, to prevent mixing up



**11.14a** Measure the spark plug gap with a feeler gauge . . .



**11.14b** . . . or adjusting tool . . .



**11.14c** . . . then use the end of the special tool to adjust the gap





12.1a Removing the air cleaner cover . . .



12.1b . . . and element on 4-cylinder engines with single-point fuel injection



12.1c Lift the element out of the housing, together with its support frame on V6 engines

the firing order, which is essential for proper engine operation. Gain access to the leads and disconnect them as described above for the spark plug check and renewal.

**20** Check inside the boot for corrosion, which will look like a white crusty powder. Clean this off as much as possible; if it is excessive, or if cleaning leaves the metal connector too badly corroded to be fit for further use, the lead must be renewed. Push the lead and boot back onto the end of the spark plug. The boot should fit tightly onto the end of the plug - if it doesn't, remove the lead and use pliers carefully to crimp the metal connector inside the boot until the fit is snug.

**21** Using a clean rag, wipe the entire length of the lead to remove built-up dirt and grease. Once the lead is clean, check for burns, cracks and other damage. Do not bend the lead sharply, because the conductor might break.

**22** Inspect the remaining spark plug (HT) leads, ensuring that each is securely fastened at the distributor cap and spark plug when the check is complete. If any sign of arcing, severe connector corrosion, burns, cracks or other damage is noticed, obtain new spark plug (HT) leads, renewing them as a set. If new spark plug leads are to be fitted, remove and refit them one at a time, to avoid mix-ups in the firing order.

**23** Refer to Chapter 5 and remove the distributor cap then thoroughly clean it inside and out with a dry lint-free rag.

**24** Examine the HT lead segments inside the cap. If they appear badly burned or pitted renew the cap. Also check the carbon brush in the centre of the cap, ensuring that it is free to move and stands proud of its holder. Make sure that there are no sign of cracks or black "tracking" lines running down the inside of the cap, which will also mean renewal if evident. Refit the cap as described in Chapter 5 on completion.

## 12 Air cleaner element renewal



**1** The air cleaner filter element is located in the air cleaner assembly mounted on the left-

hand side of the engine compartment. Undo the retaining screws and/or release the clips, and lift the air cleaner cover, disconnecting the vacuum hose where fitted. Lift the element out of the housing, together with its support frame on V6 engines, and wipe out the housing (see illustrations). Check that no foreign matter is visible, either in the air intake or in the housing.

**2** If carrying out a routine service, the element must be renewed regardless of its apparent condition. If you are checking the element for any other reason, inspect its lower surface; if it is oily or very dirty, renew the element. If it is only moderately dusty, it can be re-used by blowing it clean from the upper to the lower surface with compressed air.



**Warning: Wear eye protection when using compressed air! Because it is a pleated-paper type filter, it cannot be washed**

**or re-oiled. If it cannot be cleaned satisfactorily with compressed air, discard and renew it.**

**Caution: Never drive the vehicle with the air cleaner filter element removed.**

**Excessive engine wear could result, and backfiring could even cause a fire under the bonnet.**

**3** Refitting is the reverse of the removal procedure. Ensure that the element and cover are securely seated, so that unfiltered air cannot enter the engine.

## 13 Electrical system check



**1** Check the operation of all external lights and indicators (front and rear).

**2** Check for satisfactory operation of the instrument panel, its illumination and warning lights, the switches and their function lights.

**3** Check the horn(s) for satisfactory operation.

**4** Check all other electrical equipment for satisfactory operation.

**5** Check all electrical wiring in the engine compartment for correct routing, and for any signs of physical or heat-damage or chafing.

## 14 Battery check, maintenance and charging



**Warning: Certain precautions must be followed when checking and servicing the battery. Hydrogen gas, which is highly flammable, is always present in the battery cells, so keep lighted tobacco and all other open flames and sparks away from the battery. The electrolyte inside the battery is actually dilute sulphuric acid, which will cause injury if splashed on your skin or in your eyes. It will also ruin clothes and painted surfaces. When disconnecting the battery, always detach the negative (earth) lead first and connect it last!**

**Note: Before disconnecting the battery, refer to Section 1 of Chapter 5.**

### General

**1** A routine preventive maintenance programme for the battery in your vehicle is the only way to ensure quick and reliable starts. Before performing any battery maintenance, make sure that you have the proper equipment necessary to work safely around the battery.

**2** There are also several precautions that should be taken whenever battery maintenance is performed. Before servicing the battery, always turn the engine and all accessories off, and disconnect the lead from the negative terminal of the battery - see Chapter 5, Section 1.

**3** The battery produces hydrogen gas, which is both flammable and explosive. Never create a spark, smoke, or light a match around the battery. Always charge the battery in a well-ventilated area.

**4** Electrolyte contains poisonous and corrosive sulphuric acid. Do not allow it to get in your eyes, on your skin, or on your clothes. Never ingest it. Wear protective safety glasses when working near the battery. Keep children away from the battery.

**5** Note the external condition of the battery. If the positive terminal and lead clamp on your vehicle's battery is equipped with a plastic

## 1•16 Every 12 000 miles

cover or rubber protector, make sure that it's not torn or damaged. It should completely cover the terminal. Look for any corroded or loose connections, cracks in the case or cover, or loose hold-down clamps. Check the entire length of each lead for cracks and frayed conductors.

**6** If corrosion, which looks like white, fluffy deposits is evident, particularly around the terminals, the battery should be removed for cleaning as described in Chapter 5, Section 2.

**7** Clean the lead clamps thoroughly, using a soft wire brush or a terminal cleaner, with a solution of warm water and baking soda. Wash the terminals and the top of the battery case with the same solution, but make sure that the solution doesn't get into the battery. When cleaning the leads, terminals and battery top, wear safety goggles and rubber gloves, to prevent any solution from coming in contact with your eyes or hands. Wear old clothes too - even when diluted, acid splashed onto clothes will burn holes in them. Wash all cleaned areas with plain water.

**8** Make sure that the battery tray is in good condition and the hold-down clamp nuts are tight. If the battery is removed from the tray, make sure no parts remain in the bottom of the tray when the battery is refitted. When refitting the hold-down clamp nuts, do not overtighten them.

**9** Information on jump starting can be found at the front of this manual. For more detailed battery checking procedures, refer to the Haynes *Automobile Electrical and Electronic Systems Manual*.

### Cleaning

**10** Corrosion on the hold-down components, battery case and surrounding areas can be removed with a solution of water and baking soda. Thoroughly rinse all cleaned areas with plain water.

**11** Any metal parts of the vehicle damaged by corrosion should be covered with a zinc-based primer, then painted.

### Charging

 **Warning: When batteries are being charged, hydrogen gas, which is very explosive and flammable, is produced. Do not smoke, or allow open flames, near a charging or a recently-charged battery. Wear eye protection when near the battery during charging. Also, make sure the charger is unplugged before connecting or disconnecting the battery from the charger.**

**12** Slow-rate charging is the best way to restore a battery that's discharged to the point where it will not start the engine. It's also a good way to maintain the battery charge in a vehicle that's only driven a few miles between starts. Maintaining the battery charge is particularly important in winter, when the battery must work harder to start the engine, and electrical accessories that drain the battery are in greater use.

**13** It's best to use a one- or two-amp battery charger (sometimes called a "trickle" charger). They are the safest, and put the least strain on the battery. They are also the least expensive. For a faster charge, you can use a higher-ampere charger, but don't use one rated more than 1/10th the amp/hour rating of the battery (ie no more than 5 amps, typically). Rapid boost charges that claim to restore the power of the battery in one to two hours are hardest on the battery, and can damage batteries not in good condition. This type of charging should only be used in emergency situations.

**14** The average time necessary to charge a battery should be listed in the instructions that come with the charger. As a general rule, a trickle charger will charge a battery in 12 to 16 hours.

### 15 Seat belt check



**1** Check the seat belts for satisfactory operation and condition. Inspect the webbing for fraying and cuts. Check that they retract smoothly and without binding into their reels.

**2** Check that the seat belt mounting bolts are tight, and if necessary tighten them to the specified torque wrench setting (see Chapter 11).

### 16 Auxiliary drivebelts check and renewal



#### General

**1** The number and type of auxiliary drivebelts depends on the engine, year of manufacture, and whether or not the vehicle is equipped with air conditioning. The belt will be either a V-belt or a flat, multi-ribbed (or "polyvee") type. All the drivebelts are located on the right-hand end of the engine and are driven from the crankshaft pulley. Early "M" series 4-cylinder engines have an additional drivebelt for the power steering pump, which is driven from a pulley on the camshaft.



16.6a Alternator adjustment bracket bolts (arrowed) . . .

**2** The good condition and proper tension of the auxiliary drivebelts is critical to the operation of the engine. Because of their composition and the high stresses to which they are subjected, drivebelts stretch and deteriorate as they get older. They must, therefore, be regularly inspected.

#### Check

**3** With the engine switched off, open and support the bonnet, then locate the auxiliary drivebelts fitted to your car (Be very careful, and wear protective gloves to minimise the risk of burning your hands on hot components, if the engine has recently been running). For improved access, jack up the front of the vehicle, support it securely on axle stands, remove the roadwheel, then remove the cover from inside the wheelarch.

**4** Using an inspection light or a small electric torch, and rotating the engine when necessary with a spanner applied to the crankshaft pulley bolt, check the whole length of the drivebelt for cracks, separation of the rubber, and torn or worn ribs. Also check for fraying and glazing, which gives the drivebelt a shiny appearance. Both sides of the drivebelt should be inspected, and you will have to twist the drivebelt to check the underside. Use your fingers to feel the drivebelt where you can't see it. If you are in any doubt as to the condition of the drivebelt, renew it.

### Drivebelt tension - 4-cylinder engines

#### Alternator drivebelt (early "M" series engines)

**5** Check that it is just possible to twist the belt by hand through 90° at a point midway between the two pulleys. If adjustment is necessary, proceed as follows.

**6** Slacken the two alternator adjustment bracket bolts and the alternator pivot bolt and nut (see illustrations).

**7** Lever the alternator away from the engine until the drivebelt is moderately tight. The alternator must only be levered with care at the drive end bracket. Hold the alternator in this position and tighten the adjustment bracket bolts and pivot nut and bolt.



16.6b . . . and pivot bolt retaining nut on early "M" series 4-cylinder engines

**Power steering pump drivebelt (early "M" series engines)**

8 Refer to Chapter 4, Part A or B, and remove the air cleaner components as necessary, for access.

9 Undo the retaining screw and remove the cover over the camshaft pulley (see illustration).

10 Undo the bolts securing the coolant bypass pipe to the cylinder head and to the main coolant pipe, and move the bypass pipe aside as necessary for access.

11 To check and adjust the belt tension accurately it will be necessary to obtain a socket to fit the power steering pump pulley retaining nut, a socket bar of at least 12 inches in length, and a spring balance capable of recording a minimum of 25 lbs. Make a paint mark or similar on the socket bar, 12 inches up from the centre of the square drive end.

12 Slacken the centre retaining nut on the belt tensioner wheel, then turn the tension adjuster bolt clockwise until the belt is slack. Retighten the tensioner wheel retaining nut to 5.0 Nm.

13 Fit the socket and bar to the pump pulley retaining nut, and position it so that the socket bar is vertical.

14 Attach the spring balance to the socket bar at the point marked 12 inches up from the square drive end.

15 Turn the adjuster bolt anti-clockwise until it takes a pull of 25 lbs to make the pump pulley slip. This procedure is shown (see illustration 16.9), but using the Rover special tool. The socket and bar are a substitute for this tool.

16 Remove the socket, bar and spring balance, then turn the crankshaft until the camshaft pulley has turned through 180°.

17 Check the belt tension again, and re-adjust if necessary.

18 Now turn the tension adjuster bolt anti-clockwise two complete turns.

19 Tighten the tensioner wheel retaining nut fully to the specified torque.

20 Refit the coolant pipe retaining bolts, and the cover over the camshaft pulley.

21 Refit the air cleaner components.

**Alternator/power steering pump/air conditioning compressor drivebelt (later "M" series engines)**

22 Accurate tensioning of the drivebelt on cars with this arrangement can only be achieved with the Rover belt tensioning tool, and ideally this operation should be carried out by a Rover dealer. However, if a new belt has been fitted, or if the existing tension is extremely slack, a rough approximation as a temporary measure can be achieved using the following procedure.

23 To adjust the belt tension, slacken the idler pulley retaining nut, then turn the adjuster bolt clockwise to increase the tension or anti-clockwise to decrease it, until it is just possible to twist the belt by hand through 90° at a point midway between the crankshaft and power steering pump pulleys (see illustration).

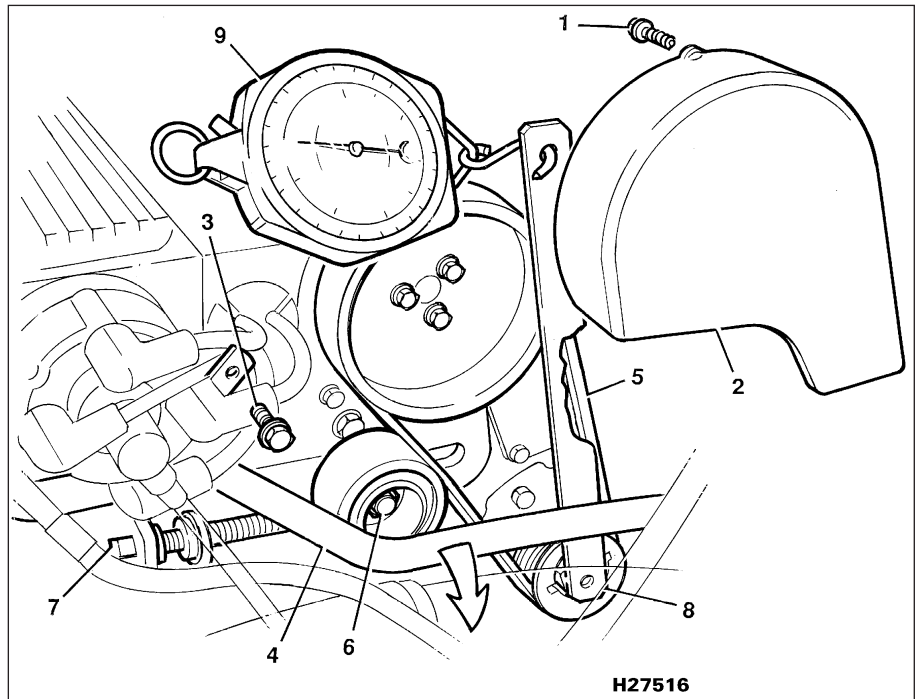

**16.9 Power steering pump drivebelt adjustment on early "M" series 4-cylinder engines**

- |   |   |   |
|---|---|---|
| 1 Camshaft pulley cover retaining screw | 4 Coolant pipe                              | 7 Tension adjuster bolt                   |
| 2 Camshaft pulley cover                 | 5 Drivebelt                                 | 8 Rover special tool for checking tension |
| 3 Coolant pipe retaining bolt           | 6 Belt tensioner wheel centre retaining nut | 9 Spring balance                          |

1

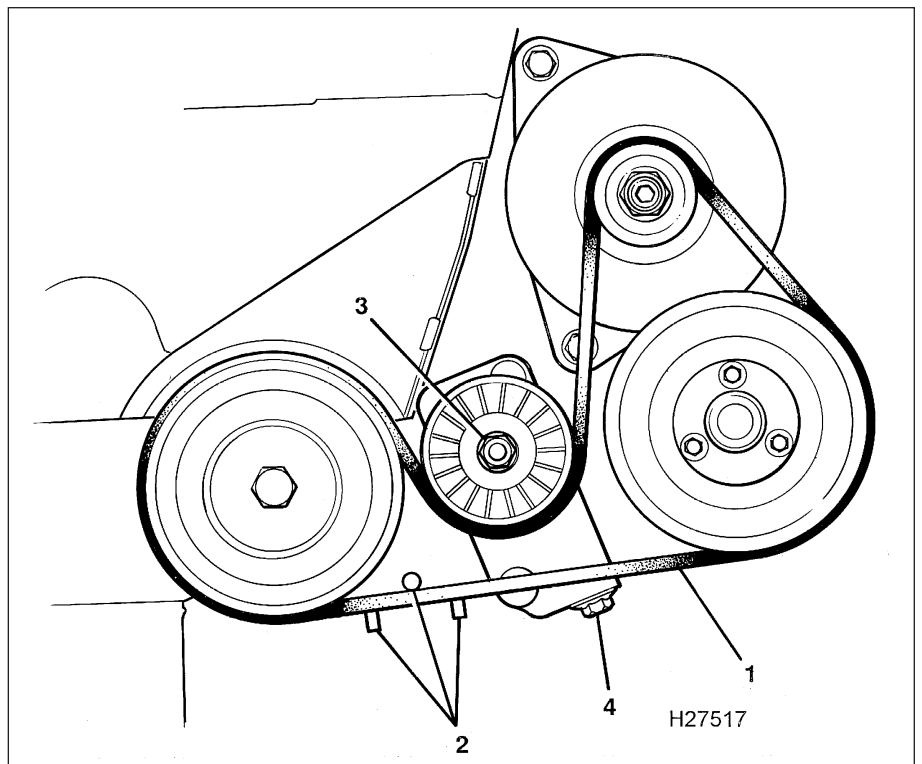

**16.23 Drivebelt adjustment on later "M" series 4-cylinder engines**

- |             |                                       |                              |
|-------------|---------------------------------------|------------------------------|
| 1 Drivebelt | 2 Checking gauge - Rover special tool | 3 Idler pulley retaining nut |
|             |                                       | 4 Adjuster bolt              |



# 1•18 Every 12 000 miles

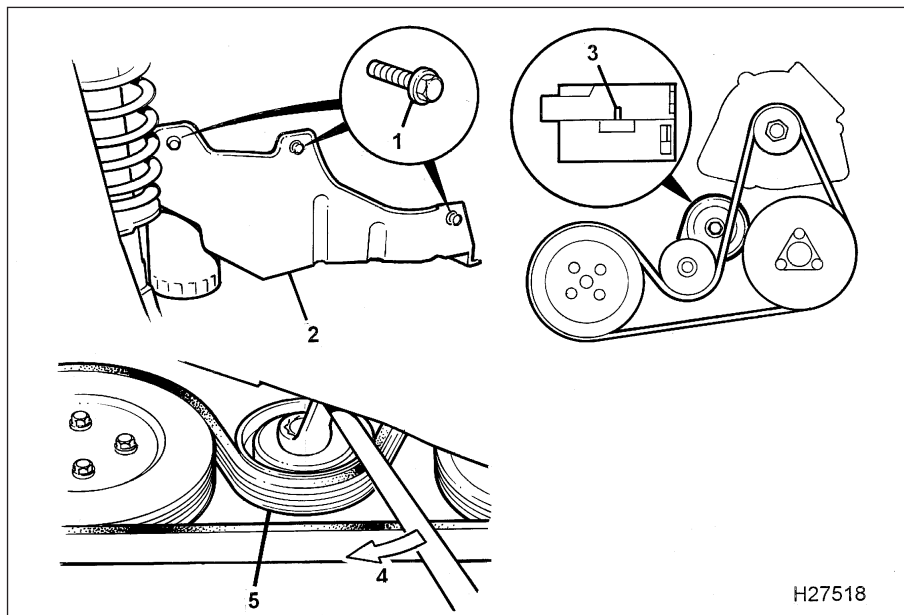

16.25 Drivebelt adjustment details on "T" series engines

- |                                  |                            |  |
|----------------------------------|----------------------------|--|
| 1 Wheelarch cover retaining bolt | 2 Wheelarch cover          | 4 Releasing the tensioner for belt renewal |
|                                  | 3 Tensioner wear indicator | 5 Drivebelt                                |

24 When the tension is correct, tighten the idler pulley retaining nut to the specified torque and lower the car to the ground.

## Alternator/power steering pump/air conditioning compressor drivebelt ("T" series engines)

25 "T" series engines are fitted with an automatic drivebelt tensioner incorporating a wear indicator to show when the belt has stretched too far for the tensioner to maintain correct adjustment (see illustration).

26 To check the tension, observe the wear indicator and make sure that the pointer has not reached the right-hand end of the slot. If it hasn't, all is well, and no further action is necessary: if it has, renew the belt.

## Drivebelt tension - V6 engines

### Alternator drivebelt

27 Undo the three bolts and one nut securing the power steering pump and alternator pulley

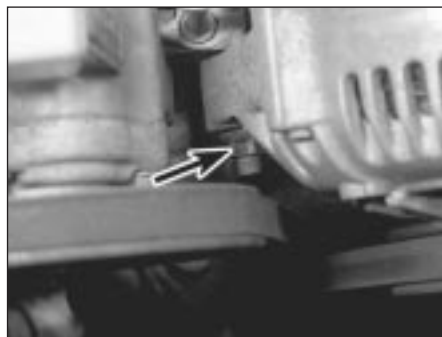

16.29b ... and lower mounting nut (arrowed), then turn the adjusting bolt to achieve the correct tension

covers to the top of the engine. Move the pipes and cables clear and lift off the covers (see illustration).

28 The belt tension is correct when it is just possible to deflect the belt by 18 to 22 mm at the mid-point of its run, under moderate finger pressure. If adjustment is required, proceed as follows.

29 Slacken the alternator side pivot bolt and lower mounting nut, then turn the adjusting bolt on the side of the unit as necessary to achieve the correct tension (see illustrations).

30 Tighten the pivot and mounting nuts and bolts and refit the covers to the top of the engine.

### Power steering pump drivebelt

31 Undo the three bolts and one nut securing the power steering pump and alternator pulley covers to the top of the engine. Move the pipes and cables clear and lift off the covers.



16.33a Slacken the V6 engine power steering pump adjusting nut ...



16.27 On V6 engines, remove the pulley covers over the top of the engine ...



16.29a ... slacken the alternator side pivot bolt (arrowed) ...

32 The belt tension is correct when it is just possible to deflect the belt by 18 to 22 mm at the mid-point of its run, under moderate finger pressure. If adjustment is required, proceed as follows.

33 Slacken the pump adjusting nut and mounting bolt, then engage the end of a 1/2 inch square drive socket bar in the hole at the rear of the large lug on top of the pump (see illustrations). Using the bar, move the pump as necessary, until the belt tension is correct, then tighten the adjusting and mounting nut and bolt.

### Air conditioning compressor drivebelt

34 The belt tension is correct when it is just possible to deflect the belt by 7 to 9 mm at a point mid-way between the crankshaft pulley and the tensioner jockey wheel, under



16.33b ... then engage the end of a socket bar in the lug on top of the pump to adjust the belt



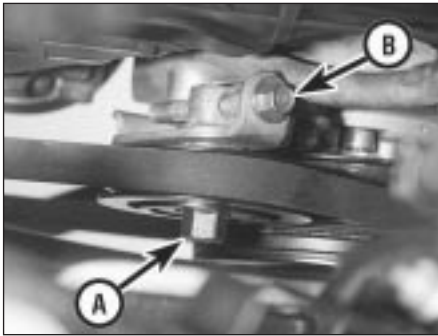

**16.35 Air conditioning compressor drivebelt tensioner jockey wheel bolt (A), and adjusting bolt (B) on V6 engines**

moderate finger pressure. If adjustment is required, proceed as follows.

**35** Slacken the bolt in the centre of the tensioner jockey wheel, then turn the adjusting bolt, behind the adjuster, to obtain the correct belt tension (see illustration). When the adjustment is correct, tighten the jockey wheel bolt.

**Renewal - 4-cylinder engines**

**36** Open the bonnet, jack up the front of the vehicle (where applicable) and support it securely on an axle stands, remove the roadwheel, then remove the cover from inside the wheelarch.

**37** The routing of the drivebelt around the pulleys is dependant on the drivebelt type and whether or not air conditioning is fitted. Before removing the drivebelt, it's a good idea to sketch the belt run around the pulleys; this will save a lot of frustration when it comes to refitting.

**38** If the existing drivebelt is to be refitted, mark it, or note the maker's markings on its flat surface, so that it can be installed in the same way.

**39** To renew the drivebelt, slacken the belt tension fully as described above according to type, noting that where an automatic tensioner is fitted, it is only necessary to turn the tensioner centre bolt clockwise, using a spanner, to release the belt tension. Slip the belt off the pulleys then fit the new belt ensuring that it is routed correctly. With the belt in position, adjust the tension as previously described, or simply release the tensioner bolt.

**40** Using a spanner applied to the crankshaft pulley bolt, rotate the crankshaft through at least two full turns clockwise to settle the drivebelt on the pulleys, then check that the drivebelt is properly installed.

**41** Refit the cover and roadwheel, then lower the vehicle to the ground.

**Renewal - V6 engines**

**42** Open the bonnet, jack up the front of the vehicle (where applicable) and support it securely on an axle stands, remove the roadwheel, then remove the cover from inside the wheelarch.

**43** If the existing drivebelt is to be refitted, mark it, or note the maker's markings on its flat surface, so that it can be installed the same way.

**44** Depending on which drivebelt is to be renewed, it will probably be necessary to remove one (or both) of the other drivebelts first, to gain access. Note also, that if the power steering pump drivebelt is to be renewed, it will be necessary to support the engine under the sump on a jack (with interposed block of wood) and undo the two bolts on the right-hand engine mounting, to allow the belt to pass through.

**45** To renew the drivebelt, slacken the belt tension fully as described above according to type. Slip the belt off the pulleys then fit the new belt. With the belt in position, refit the engine mounting bolts (where applicable) and adjust the tension as previously described.

**46** Using a spanner applied to the crankshaft pulley bolt, rotate the crankshaft through at least two full turns clockwise to settle the drivebelt on the pulleys, then check that the drivebelt is properly installed.

**47** Refit the cover and roadwheel, then lower the vehicle to the ground.

**17 Engine compartment wiring check**



**1** With the vehicle parked on level ground, apply the handbrake firmly and open the bonnet. Using an inspection light or a small electric torch, check all visible wiring within and beneath the engine compartment.

**2** What you are looking for is wiring that is obviously damaged by chafing against sharp edges, or against moving suspension/transmission components and/or the auxiliary drivebelts, by being trapped or crushed between carelessly-refitted components, or melted by being forced into contact with the hot engine castings, coolant pipes, etc. In almost all cases, damage of this sort is caused in the first instance by incorrect routing on reassembly after previous work has been carried out.

**3** Depending on the extent of the problem, damaged wiring may sometimes be repaired by rejoining the break or splicing-in a new length of wire, using solder to ensure a good connection, and remaking the insulation with adhesive insulating tape or heat-shrink tubing, as appropriate. If the damage is extensive, given the implications for the vehicle's future reliability, the best long-term answer may well be to renew that entire section of the loom, however expensive this may appear.

**4** When the actual damage has been repaired, ensure that the wiring loom is re-routed correctly, so that it is clear of other components, and not stretched or kinked, and is secured out of harm's way using the plastic clips, guides and ties provided.

**5** Check all electrical connectors, ensuring

that they are clean, securely fastened, and that each is locked by its plastic tabs or wire clip, as appropriate. If any connector shows external signs of corrosion (accumulations of white or green deposits, or streaks of "rust"), or if any is thought to be dirty, it must be unplugged and cleaned using electrical contact cleaner. If the connector pins are severely corroded, the connector must be renewed; note that this may mean the renewal of that entire section of the loom - see your local Rover dealer for details.

**6** If the cleaner completely removes the corrosion to leave the connector in a satisfactory condition, it would be wise to pack the connector with a material which will exclude dirt and moisture, preventing the corrosion from occurring again.

**7** Check the condition of the battery connections - remake the connections or renew the leads if a fault is found. Use the same techniques to ensure that all earth points in the engine compartment provide good electrical contact through clean, metal-to-metal joints, and that all are securely fastened.

**8** Refer to Section 11 for details of spark plug (HT) lead checks.

**18 Air conditioning system check**



**Warning: The air conditioning system is under high pressure. Do not loosen any fittings or remove any components until after the system has been discharged. Air conditioning refrigerant must be properly discharged into an approved type of container, at a dealer service department or an automotive air conditioning repair facility capable of handling the refrigerant safely. Always wear eye protection when disconnecting air conditioning system fittings.**

**1** The following maintenance checks should be performed on a regular basis, to ensure that the air conditioner continues to operate at peak efficiency:

- (a) Check the auxiliary drivebelt. If it's worn or deteriorated, renew it (see Section 16).
- (b) Check the system hoses. Look for cracks, bubbles, hard spots and deterioration. Inspect the hoses and all fittings for oil bubbles and seepage. If there's any evidence of wear, damage or leaks, renew the hose(s).
- (c) Inspect the condenser fins for leaves, insects and other debris. Use a "fin comb" or compressed air to clean the condenser.



**Warning: Wear eye protection when using compressed air!**

- (d) Check that the drain tube from the front of the evaporator is clear - note that it is normal to have clear fluid (water) dripping

# 1•20 Every 12 000 miles

from this while the system is in operation, to the extent that quite a large puddle can be left under the vehicle when it is parked.

2 It's a good idea to operate the system for about 30 minutes at least once a month, particularly during the winter. Long term non-use can cause hardening, and subsequent failure, of the seals.

3 Because of the complexity of the air conditioning system and the special equipment necessary to service it, in-depth fault diagnosis and repairs are not included in this manual. For more complete information on the air conditioning system, refer to the Haynes "Automotive Heating and Air Conditioning Manual".

4 The most common cause of poor cooling is simply a low system refrigerant charge. If a noticeable drop in cool air output occurs, the following quick check will help you determine if the refrigerant level is low.

5 Warm the engine up to normal operating temperature.

6 Place the air conditioning temperature selector at the coldest setting, and put the blower at the highest setting. Open the doors - to make sure the air conditioning system doesn't cycle off as soon as it cools the passenger compartment.

7 With the compressor engaged - the clutch will make an audible click, and the centre of the clutch will rotate - feel the inlet and outlet pipes at the compressor. One side should be cold, and one hot. If there's no perceptible difference between the two pipes, there's something wrong with the compressor or the system. It might be a low charge - it might be something else. Take the vehicle to a dealer service department or an automotive air conditioning specialist.

## 19 Engine base idle speed and CO content check



Refer to the appropriate Parts of Chapter 4.

## 20 Manual transmission oil level check



1 The manual transmission does not have a dipstick. To check the oil level, raise the vehicle and support it securely on axle stands, making sure that the vehicle is level. On the left-hand side of the transmission casing, to the rear of the constant velocity joint, you will see the filler/level plug. Wipe around the plug with a rag, then unscrew and remove it. If the level is correct, the oil should be up to the lower edge of the hole.

2 If the transmission needs more lubricant (if the oil level is not up to the hole), use a syringe, or a plastic bottle and tube, to add more (see illustration). Stop filling the transmission when the lubricant begins to run

out of the hole. Make sure that you refer to "Lubricants, fluids and capacities" at the beginning of this Chapter for the correct grade of lubricant to use, according to transmission type.

3 Refit the filler/level plug, and tighten it to the specified torque wrench setting. Drive the vehicle a short distance, then check for leaks.

4 A need for regular topping-up can only be due to a leak, which should be found and rectified without delay.

## 21 Steering, suspension and roadwheel check



### Front suspension and steering check

1 Apply the handbrake, then raise the front of the vehicle and support it on axle stands.

2 Visually inspect the balljoint dust covers and the steering gear gaiters for splits, chafing or deterioration. Any wear of these components will cause loss of lubricant, together with dirt and water entry, resulting in rapid deterioration of the balljoints or steering gear.

3 Check the power-assisted steering fluid hoses for chafing or deterioration, and the pipe and hose unions for fluid leaks. Also check for signs of fluid leakage under pressure from the steering gear rubber gaiters, which would indicate failed fluid seals within the steering gear.

4 Check for signs of fluid leakage around the shock absorber body, or from the rubber boot around the piston rod (where fitted). Should any fluid be noticed, the shock absorber is defective internally, and renewal is necessary.

5 Grasp the roadwheel at the 12 o'clock and 6 o'clock positions, and try to rock it. Very slight free play may be felt, but if the movement is appreciable, further investigation is necessary to determine the source. Continue rocking the wheel while an assistant depresses the footbrake. If the movement is now eliminated or significantly reduced, it is likely that the hub bearings are at fault. If the free play is still evident with the footbrake depressed, then there is wear in the suspension joints or mountings.



20.2 Topping up the manual transmission oil

6 Now grasp the wheel at the 9 o'clock and 3 o'clock positions, and try to rock it as before. Any movement felt now may again be caused by wear in the hub bearings or the steering track rod balljoints. If the outer track rod end balljoint is worn, the visual movement will be obvious. If the inner joint is suspect, it can be felt by placing a hand over the rack-and-pinion rubber gaiter, and gripping the track rod. If the wheel is now rocked, movement will be felt at the inner joint if wear has taken place.

7 Using a large screwdriver or flat bar, check for wear in the suspension mounting bushes by levering between the relevant suspension component and its attachment point. Some movement is to be expected as the mountings are made of rubber, but excessive wear should be obvious. Also check the condition of any visible rubber bushes, looking for splits, cracks or contamination of the rubber.

8 With the vehicle standing on its wheels, have an assistant turn the steering wheel back-and-forth, about an eighth of a turn each way. There should be very little, if any, lost movement between the steering wheel and roadwheels. If this is not the case, closely observe the joints and mountings previously described, but in addition, check the steering column universal joints for wear, and also check the rack-and-pinion steering gear itself.

9 The efficiency of the shock absorber may be checked by bouncing the car at each front corner. Generally speaking, the body will return to its normal position and stop after being depressed. If it rises and returns on a rebound, the shock absorber is probably suspect. Examine also the shock absorber upper and lower mountings for any signs of wear.

### Rear suspension check

10 Chock the front wheels, then raise the rear of the vehicle and support it on axle stands.

11 Check the rear hub bearings for wear, using the method described for the front hub bearings (paragraph 4).

12 Using a large screwdriver or flat bar, check for wear in the suspension mounting bushes by levering between the relevant suspension component and its attachment point. Some movement is to be expected as the mountings are made of rubber, but excessive wear should be obvious. Check the condition of the shock absorbers as described previously.

### Roadwheel check and balancing

13 Periodically remove the roadwheels, and clean any dirt or mud from the inside and outside surfaces. Examine the wheel rims for signs of rusting, corrosion or other damage. Light alloy wheels are easily damaged by "kerbing" whilst parking, and similarly, steel wheels may become dented or buckled. Renewal of the wheel is very often the only course of remedial action possible.

14 The balance of each wheel and tyre

assembly should be maintained, not only to avoid excessive tyre wear, but also to avoid wear in the steering and suspension components. Wheel imbalance is normally signified by vibration through the vehicle's bodyshell, although in many cases it is particularly noticeable through the steering wheel. Conversely, it should be noted that wear or damage in suspension or steering components may cause excessive tyre wear. Out-of-round or out-of-true tyres, damaged wheels and wheel bearing wear/maladjustment also fall into this category. Balancing will not usually cure vibration caused by such wear.

**15** Wheel balancing may be carried out with the wheel either on or off the vehicle. If balanced on the vehicle, ensure that the wheel-to-hub relationship is marked in some way prior to subsequent wheel removal, so that it may be refitted in its original position.

## 22 Driveshaft rubber gaiter and CV joint check



**1** The driveshaft rubber gaiters are very important, because they prevent dirt, water and foreign material from entering and damaging the constant velocity (CV) joints. External contamination can cause the gaiter material to deteriorate prematurely, so it's a good idea to wash the gaiters with soap and water occasionally.

**2** With the vehicle raised and securely supported on axle stands, turn the steering onto full-lock, then slowly rotate each front wheel in turn. Inspect the condition of the outer constant velocity (CV) joint rubber gaiters, squeezing the gaiters to open out the folds. Check for signs of cracking, splits, or deterioration of the rubber, which may allow the escape of grease, and lead to the ingress of water and grit into the joint. Also check the security and condition of the retaining clips. Repeat these checks on the inner CV joints. If any damage or deterioration is found, the gaiters should be renewed as described in Chapter 8.

**3** At the same time, check the general condition of the outer CV joints themselves,



**23.2** Typical exhaust system rubber mountings and brackets

by first holding the driveshaft and attempting to rotate the wheels. Repeat this check on the inner joints, by holding the inner joint yoke and attempting to rotate the driveshaft.

**4** Any appreciable movement in the CV joint indicates wear in the joint, wear in the driveshaft splines, or a loose driveshaft retaining nut.

## 23 Exhaust system check

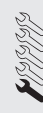

**1** With the engine cold (at least three hours after the vehicle has been driven), check the complete exhaust system, from its starting point at the engine to the end of the tailpipe. Ideally, this should be done on a hoist, where unrestricted access is available; if a hoist is not available, raise and support the vehicle on axle stands.

**2** Check the pipes and connections for evidence of leaks, severe corrosion, or damage. Make sure that all brackets and rubber mountings are in good condition, and tight; if any of the mountings are to be renewed, ensure that the replacements are of the correct type (see illustration). Leakage at any of the joints or in other parts of the system will usually show up as a black sooty stain in the vicinity of the leak. **Note:** *Exhaust sealants should not be used on any part of the exhaust system upstream of the catalytic converter - even if the sealant does not contain additives harmful to the converter, pieces of it may break off and foul the element, causing local overheating.*

**3** At the same time, inspect the underside of the body for holes, corrosion, open seams, etc. which may allow exhaust gases to enter the passenger compartment. Seal all body openings with silicone or body putty.

**4** Rattles and other noises can often be traced to the exhaust system, especially the rubber mountings. Try to move the system, silencer(s) and catalytic converter. If any components can touch the body or suspension parts, secure the exhaust system with new mountings.

## 24 Underbody and fuel/brake line check

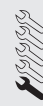

**1** With the vehicle raised and supported on axle stands or over an inspection pit, thoroughly inspect the underbody and wheelarches for signs of damage and corrosion. In particular, examine the bottom of the side sills, and any concealed areas where mud can collect. Where corrosion and rust is evident, press and tap firmly on the panel with a screwdriver, and check for any serious corrosion which would necessitate repairs. If the panel is not seriously corroded, clean away the rust, and apply a new coating of

underseal. Refer to Chapter 11 for more details of body repairs.

**2** At the same time, inspect the PVC-coated lower body panels for stone damage and general condition.

**3** Inspect all of the fuel and brake lines on the underbody for damage, rust, corrosion and leakage. Also make sure that they are correctly supported in their clips. Where applicable, check the PVC coating on the lines for damage.

## 25 Clutch operation and hydraulic hose condition check



**1** Check the clutch pedal moves smoothly and easily through its travel, and that the clutch functions correctly, with no trace of slip or drag.

**2** Remove the closing panels under the fascia for access to the pedal and apply a few drops of light oil to the pedal pivot. Refit the panel.

**3** From within the engine compartment check the condition of the fluid lines and hoses as described in Section 8. Now have a look under the front of the car at the clutch slave cylinder. Check for signs of fluid leaks around the rubber boot and check the security of the linkage. Apply a few drops of oil to the pushrod clevis pin and linkage.

## 26 Brake check



**Note:** *For detailed photographs of the brake system, refer to Chapter 9.*

**1** The work described in this Section should be carried out at the specified intervals, or whenever a defect is suspected in the braking system. Any of the following symptoms could indicate a potential brake system defect:

- (a) *The vehicle pulls to one side when the brake pedal is depressed.*
- (b) *The brakes make scraping or dragging noises when applied.*
- (c) *Brake pedal travel is excessive.*
- (d) *The brake fluid requires repeated topping-up.*

**2** A thorough inspection should be made to confirm the thickness of the pad linings, as follows.

**3** Jack up the front or rear of the vehicle in turn, and support it on axle stands.

**4** For better access to the brake calipers, remove the wheels.

**5** Look through the inspection window in the caliper, and check that the thickness of the friction lining material on each of the pads is not less than the recommended minimum thickness given in the Specifications. **Note:** *Bear in mind that the lining material is normally bonded to a metal backing plate.*

**6** If it is difficult to determine the exact thickness of the pad linings, or if you are at all



# 1•22 Every 12 000 miles

concerned about the condition of the pads, then remove them from the calipers for further inspection (refer to Chapter 9).

**7** Check the remaining brake caliper(s) in the same way.

**8** If any one of the brake pads has worn down to, or below, the specified limit, *all four* pads at that end of the car must be renewed as a set (ie all the front pads or all the rear pads).

**9** Measure the thickness of the discs with a micrometer, if available, to make sure that they still have service life remaining. If any disc is thinner than the specified minimum thickness, renew it (refer to Chapter 9). In any case, check the general condition of the discs. Look for excessive scoring and discolouration caused by overheating. If these conditions exist, remove the relevant disc and have it resurfaced or renewed (refer to Chapter 9).

**10** Before refitting the wheels, check all brake lines and hoses (refer to Chapter 9). In particular, check the flexible hoses in the vicinity of the calipers, where they are subjected to most movement. Bend them between the fingers (but do not actually bend them double, or the casing may be damaged) and check that this does not reveal previously-hidden cracks, cuts or splits. On completion, apply the handbrake and check that the rear wheels are locked. The handbrake does not normally require periodic adjustment but if its travel seems excessive, refer to Chapter 9.

## 27 Door, boot, tailgate and bonnet check and lubrication



**1** Check that the doors, bonnet and tailgate/boot lid close securely. Check that the bonnet safety catch operates correctly. Check the operation of the door check straps.

**2** Lubricate the hinges, door check straps, the striker plates and the bonnet catch sparingly with a little oil or grease.

## 28 Bodywork, paint and exterior trim check



**1** The best time to carry out this check is after the car has been washed so that any surface blemish or scratch will be clearly evident and not hidden by a film of dirt.

**2** Starting at one front corner check the paintwork all around the car, looking for minor scratches or more serious dents. Check all the trim and make sure that it is securely attached over its entire length.

**3** Check the security of all door locks, door mirrors, badges, bumpers radiator grille and wheel trim. Anything found loose, or in need of further attention should be done with reference to the relevant Chapters of this manual.

**4** Rectify any problems noticed with the paintwork or body panels as described in Chapter 11.

## 29 Roadwheel nut tightness check

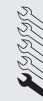

**1** Apply the handbrake and remove the wheel trim.

**2** Slacken each wheel nut in turn then, using a torque wrench, tighten it to the specified torque wrench setting. If any of the wheel nuts appear corroded, or are tight to unscrew, jack up and securely support the car at the front or rear as applicable, and remove the relevant wheel. Clean the threads of the wheel studs and apply a high-melting point copper based grease to each stud. It's a good idea to do this to all the studs at each wheel; if one was corroded, they're probably all the same.

**3** If the nuts were removed, check the torque setting again after lowering the car, then refit the wheel trim.

## 30 Road test

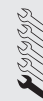

### Check the operation and performance of the braking system

**1** Make sure that the vehicle does not pull to one side when braking, and that the wheels do not lock prematurely when braking hard.

**2** Check that there is no vibration through the steering when braking.

**3** Check that the handbrake operates correctly, without excessive movement of the lever, and that it holds the vehicle stationary on a slope.

**4** With the engine switched off, test the operation of the brake servo unit as follows. Depress the footbrake four or five times to exhaust the vacuum, then start the engine. As the engine starts, there should be a noticeable "give" in the brake pedal as vacuum builds up. Allow the engine to run for at least two minutes, and then switch it off. If the brake pedal is now depressed again, it should be possible to detect a hiss from the servo as the pedal is depressed. After about four or five applications, no further hissing should be heard, and the pedal should feel considerably harder.

### Steering and suspension

**5** Check for any abnormalities in the steering, suspension, handling or road "feel".

**6** Drive the vehicle, and check that there are no unusual vibrations or noises.

**7** Check that the steering feels positive, with no excessive sloppiness or roughness, and check for any suspension noises when cornering and driving over bumps.

## Drivetrain

**8** Check the performance of the engine, transmission and driveshafts.

**9** Check that the engine starts correctly, both when cold and when hot.

**10** Listen for any unusual noises from the engine and transmission.

**11** Make sure that the engine runs smoothly when idling, and that there is no hesitation when accelerating.

**12** On manual transmission models, check that all gears can be engaged smoothly without noise, and that the gear lever action is not abnormally vague or "notchy".

**13** On automatic transmission models, make sure that the drive seems smooth without jerks or engine speed "flare-ups". Check that all the gear positions can be selected with the vehicle at rest. If any problems are found, they should be referred to a Rover dealer.

**14** Listen for a metallic clicking sound from the front of the vehicle as the vehicle is driven slowly in a circle with the steering on full-lock. Carry out this check in both directions. If a clicking noise is heard, this indicates wear in a driveshaft joint, in which case renew the joint.

## Clutch

**15** Check that the clutch pedal moves smoothly and easily through its full travel, and that the clutch itself functions correctly, with no trace of slip or drag. If the movement is uneven or stiff in places, check the system components with reference to Chapter 6.

## Instruments and electrical equipment

**16** Check the operation of all instruments and electrical equipment.

**17** Make sure that all instruments read correctly, and switch on all electrical equipment in turn, to check that it functions properly.

## 31 Automatic transmission fluid level check



**1** The level of the automatic transmission fluid should be carefully maintained. Low fluid level can lead to slipping or loss of drive, while overfilling can cause foaming, loss of fluid and transmission damage.

**2** The transmission fluid level should only be checked when the transmission is hot (at its normal operating temperature). If the vehicle has just been driven over 10 miles (15 miles in a cold climate), and the fluid temperature is 160 to 175°F, the transmission is hot.

### 4-cylinder engine models

**3** Park the vehicle on level ground, apply the handbrake, and start the engine. While the engine is idling, depress the brake pedal and move the selector lever to the "P" (PARK) position.

**4** Remove the dipstick from its tube located



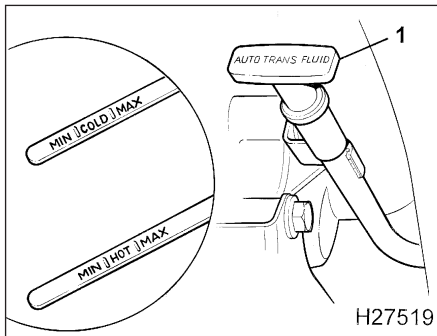

31.6 Automatic transmission fluid level dipstick (1) and level markings on 4-cylinder engine models

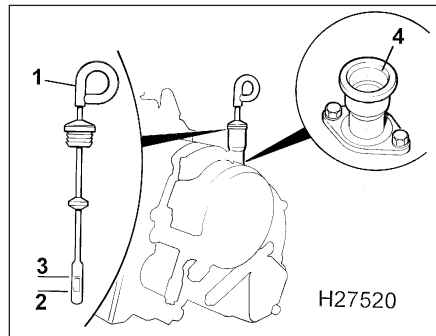

31.10 Automatic transmission fluid level dipstick (1), Lower (2) and upper (3) shaded sector and dipstick tube (4)



31.12 Add the specified automatic transmission fluid through the dipstick tube, using a clean funnel

at the front left-hand side of the engine. Note the condition and colour of the fluid on the dipstick.

5 Wipe the fluid from the dipstick with a clean rag, and re-insert it into the filler tube until the cap seats.

6 Pull the dipstick out again, and note the fluid level. The level should be between the "MIN" and "MAX" marks, on the side of the dipstick marked "HOT" (see illustration). If the level is on the "MIN" mark, stop the engine, and add the specified automatic transmission fluid through the dipstick tube, using a clean funnel if necessary. It is important not to introduce dirt into the transmission when topping-up.

7 Add the fluid a little at a time, and keep checking the level as previously described until it is correct. The difference between the "MIN" and "MAX" marks on the dipstick is approximately 0.3 litre.

### V6 engine models

8 Park the vehicle on level ground, apply the handbrake, and start the engine. While the engine is idling, depress the brake pedal and move the selector lever to the "P" (PARK) position.

9 Switch off the engine and wait one minute.

10 Remove the dipstick from its tube which is located at the rear left-hand side of the engine. The dipstick is mounted low down, on top of the transmission casing and access is not very good (see illustration). Note the condition and colour of the fluid on the dipstick.

11 Wipe the fluid from the dipstick with a clean rag, and re-insert it into the filler tube until the cap seats.

12 Pull the dipstick out again, and note the fluid level. The level should be within the shaded sector on the blade. If the level is below or very near to the bottom of the shaded sector, add the specified automatic

transmission fluid through the dipstick tube, using a clean funnel (see illustration). It is important not to introduce dirt into the transmission when topping-up.

13 Add the fluid a little at a time, and keep checking the level as previously described until it is correct. The difference between the upper and lower part of the shaded sector is approximately 0.9 litre.

### All models

14 The need for regular topping-up of the transmission fluid indicates a leak, which should be found and rectified without delay.

15 The condition of the fluid should also be checked along with the level. If the fluid at the end of the dipstick is black or a dark reddish-brown colour, or if it has a burned smell, the fluid should be changed. If you are in doubt about the condition of the fluid, purchase some new fluid, and compare the two for colour and smell.

## Every 24 000 miles or 2 years, whichever occurs first

### 32 Timing belt condition and tension check



1 The manufacturers have increased the service interval for checking the timing belt condition and tension on certain engines, due to the introduction of automatic tensioners and improvements in timing belt construction and manufacture. However, the consequences of timing belt failure can be very expensive in terms of possible engine damage and it is still worthwhile to check the belt at the shorter intervals given in this schedule. The procedures vary considerably according to engine type and model year, and reference should be made to the appropriate Part of Chapter 2 for full information.

### 33 Positive Crankcase Ventilation (PCV) system check



1 The function of the crankcase ventilation system is to reduce the emission of unburned hydrocarbons from the crankcase, and to minimise the formation of oil sludge. By ensuring that a depression is created in the crankcase under most operating conditions, particularly at idle, and by positively inducing fresh air into the system, the oil vapours and "blow-by" gases collected in the crankcase are drawn from the crankcase, through the air cleaner or oil separator, into the inlet tract, to be burned by the engine during normal combustion.

2 On four cylinder engines, the main

components of the system are an oil separator, diverter valve and associated hoses. Checking of the system consists of a simple visual check of the component hoses and their connections.

3 On V6 engines the crankcase ventilation system main components are a PCV valve, located in the breathing chamber of the front camshaft cover, and the hoses that connect to the internal channels in the inlet manifold. As with 4-cylinder engines, checking is limited to merely a visual hose condition check. Accurate checking of the PCV valve should be entrusted to a dealer.

4 Check that all components of the system are securely fastened, correctly routed (with no kinks or sharp bends to restrict flow) and in sound condition; renew any worn or damaged components.

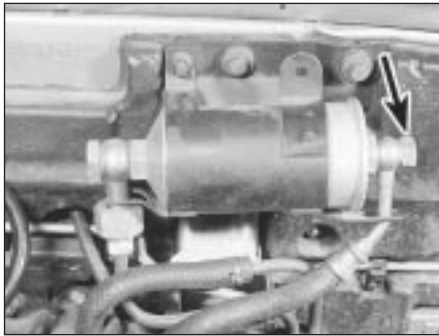

**34.3a** Fuel filter outlet union banjo bolt (arrowed) on 4-cylinder engines



**34.3b** Unscrewing the banjo union bolt on V6 engines



**34.4** On V6 engines, unscrew the inlet union nut and withdraw the pipe from the filter head

5 If oil leakage is noted, disconnect the various hoses and pipes, and check that all are clear and unblocked. Remove the air cleaner assembly cover, and check that the hose is clear and undamaged. Always ensure that the air cleaner filter element is clean as this is a vital part of the system. If it is not due for renewal but appears dirty, it may be possible to clean it as described in Section 12.

## 34 Fuel filter renewal



**Warning:** Petrol is extremely flammable, so extra precautions must be taken when working on any part of the fuel system. Do not smoke, or allow open flames or bare light bulbs, near the work area. Also, do not work in a garage if a natural gas-type appliance with a pilot light is present. While performing any work on the fuel system, wear safety glasses, and have a suitable (Class B) fire extinguisher on hand. If you spill any fuel on your skin, rinse it off immediately with soap and water.

1 On all engines, a fuel filter is provided in the fuel pump outlet line and is located on the left-hand side of the engine compartment bulkhead. The filter performs a vital role in keeping dirt and other foreign matter out of the fuel system, and so must be renewed at regular intervals, or whenever you have reason to suspect that it may be clogged.

2 Disconnect the battery negative (earth) lead (refer to Chapter 5, Section 1).

3 Place absorbent rags around the fuel filter outlet union banjo bolt, then slowly unscrew the bolt itself or, on later models, the small bleed screw in the centre of the bolt, to relieve the system pressure (see illustrations). If a bleed screw was fitted, tighten it once the pressure has been released.

4 On 4-cylinder engines, unscrew the filter inlet and outlet union banjo bolts, and recover the four copper washers. On V6 engines, unscrew the inlet union nut and withdraw the pipe from the filter head (see illustration).

5 If oil leakage is noted, disconnect the various hoses and pipes, and check that all are clear and unblocked. Remove the air cleaner assembly cover, and check that the hose is clear and undamaged. Always ensure that the air cleaner filter element is clean as this is a vital part of the system. If it is not due for renewal but appears dirty, it may be possible to clean it as described in Section 12.

Now unscrew the outlet union banjo bolt and recover the two copper washers.

5 Undo the filter bracket retaining nuts or bolts, and remove the filter (see illustration).

6 Refitting is the reverse sequence to removal, but use new copper washers on the banjo unions.

## 35 Automatic transmission fluid renewal



1 The automatic transmission fluid should be changed when the transmission is warm after the vehicle has been driven for two or three miles.

2 Position the vehicle over an inspection pit, on vehicle ramps, or jack it up, but make sure that it is level.

3 Place a large container beneath the transmission and thoroughly clean the area around the drain plug(s). On 4-cylinder engine models, undo the two socket-headed drain plugs - one on the side of the sump pan, and one on the transmission casing (see illustration). On V6 engine models undo the single drain plug on the end of the transmission casing at the front. Allow the fluid to drain into the container.



**Warning:** Take care to avoid scalding - the transmission fluid will be very hot. Remove the dipstick to speed up the draining operation.



**34.5** Undo the filter bracket retaining nuts or bolts, and remove the filter

4 When all the fluid has drained (this may take quite some time) clean the drain plug(s) then refit, together with new seals and tighten securely.

5 Lower the vehicle to the ground and apply the handbrake securely.

6 Place a funnel in the dipstick tube and fill the transmission with the specified type of fluid. Only add about half the specified amount before checking the level on the dipstick.

7 On 4-cylinder engine models, slowly add more fluid until the level just shows on the dipstick. Now start the engine with the selector lever in "P" and check the fluid level on the dipstick immediately (don't wait for the engine to warm up). Add fluid as necessary until the level is up to the "MAX" mark on the "COLD" side of the blade then refit the dipstick. Recheck the level as described in Section 31, with the engine fully warmed-up, at the earliest opportunity.

8 On V6 engine models, slowly add more fluid until the level is within the shaded sector on the dipstick blade. Refit the dipstick, drive the car until it is fully warmed-up, then recheck the level as described in Section 31.

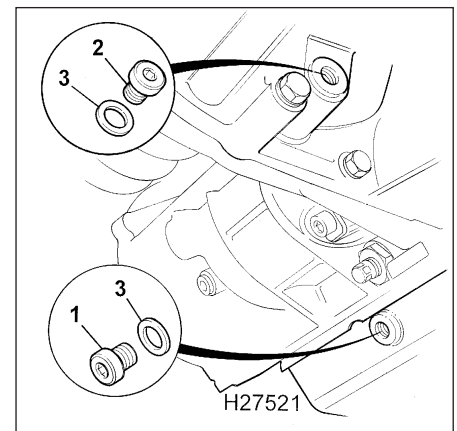

**35.3** Automatic transmission fluid drain plug locations on 4-cylinder engine models

- 1 Sump pan drain plug
- 2 Transmission casing drain plug
- 3 Sealing washers

### 36 Brake fluid renewal



The procedure is similar to that for the bleeding of the hydraulic system as described in Chapter 9, except that the brake fluid reservoir should be emptied by syphoning, and allowance should be made for the old fluid to be removed from the circuit when bleeding a section of the circuit.

### 37 Manual transmission oil renewal



- 1 Raise the vehicle and support it securely on axle stands making sure that it is level.
- 2 Place a container beneath the drain plug, which is located below the driveshaft inner constant velocity joint on the same side as the filler plug (see illustration). Undo the plug using a square key, and allow the oil to drain. If a key is not available, the 3/8 inch square drive end of a socket bar will suffice.
- 3 Refit the plug after draining, using a new sealing washer if necessary, then refill with fresh oil as described in Section 20.

### 38 Coolant renewal



**Warning:** Do not allow antifreeze to come in contact with your skin or painted surfaces of the vehicle. Flush contaminated areas immediately with plenty of water. Don't store new coolant, or leave old coolant lying around, where it's accessible to children or pets - they're attracted by its sweet smell. Ingestion of even a small amount of coolant can be fatal! Wipe up garage-floor and drip-pan spills immediately. Keep antifreeze containers covered, and repair cooling system leaks as soon as they're noticed.

**Warning:** Never remove the expansion tank filler cap when the engine is running, or has just been switched off, as the cooling system will be hot, and the consequent escaping steam and scalding coolant could cause serious injury.

#### Coolant draining

**Warning:** Wait until the engine is cold before starting this procedure.

- 1 To drain the system, first remove the expansion tank filler cap (see Section 3). Move the heater temperature control lever to the fully hot position.
- 2 If additional working clearance is required,

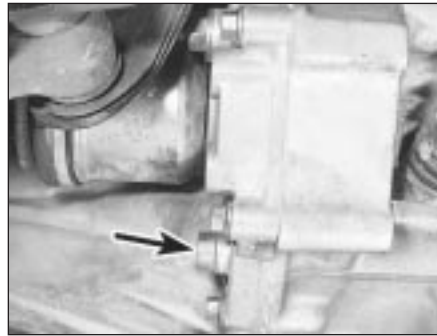

37.2 Manual transmission oil drain plug location (arrowed)

- raise the front of the vehicle and support it securely on axle stands.
- 3 Undo the retaining bolts and remove the undertray from beneath the radiator.
- 4 Place a container beneath the left-hand side of the radiator. Slacken the hose clip and carefully ease the bottom hose off the radiator outlet. Allow the coolant to drain into the container.
- 5 Additionally, on V6 engines, slacken the two cylinder block drain plugs, on the front and rear sides of the engine, and drain the cylinder block (see illustration). Use two containers for this operation, or open the drain plugs one at a time.

#### System flushing

- 6 With time, the cooling system may gradually lose its efficiency, as the radiator core becomes choked with rust, scale deposits from the water, and other sediment. To minimise this, as well as using only good-quality antifreeze and clean soft water, the system should be flushed as follows whenever any part of it is disturbed, and/or when the coolant is renewed.
- 7 With the coolant drained, refit the bottom hose and where applicable tighten the drain plugs, then refill the system with fresh water. Refit the expansion tank filler cap, start the engine and warm it up to normal operating temperature, then stop it and (after allowing it to cool down completely) drain the system again. Repeat as necessary until only clean water can be seen to emerge, then refill finally with the specified coolant mixture.
- 8 If only clean, soft water and good-quality antifreeze has been used, and the coolant has been renewed at the specified intervals, the above procedure will be sufficient to keep clean the system for a considerable length of time. If, however, the system has been neglected, a more thorough operation will be required, as follows.
- 9 First drain the coolant, then disconnect the radiator top and bottom hoses. Insert a garden hose into the top hose, and allow water to circulate through the radiator until it runs clean from the bottom outlet.
- 10 To flush the engine, insert the garden hose into the thermostat water outlet, and allow water to circulate until it runs clear from



38.5 V6 engine cylinder block drain plug (arrowed)

- the bottom hose. If, after a reasonable period, the water still does not run clear, the radiator should be flushed with a good proprietary cleaning agent.
- 11 In severe cases of contamination, reverse-flushing of the radiator may be necessary. To do this, remove the radiator (Chapter 3), invert it, and insert the garden hose into the bottom outlet. Continue flushing until clear water runs from the top hose outlet. A similar procedure can be used to flush the heater matrix.
- 12 The use of chemical cleaners should be necessary only as a last resort. Normally, regular renewal of the coolant will prevent excessive contamination of the system.

#### Coolant filling

- 13 With the cooling system drained and flushed, ensure that all disturbed hose unions are correctly secured, and that the radiator drain plug is securely tightened. Refit the radiator undershield if it was removed for access, and lower the vehicle to the ground.
- 14 Prepare a sufficient quantity of the specified coolant mixture allow for a surplus, so as to have a reserve supply for topping-up.
- 15 Slacken the cooling system bleed screw which, on early 4-cylinder engines, is located on the hose connecting the main coolant pipe to the water pump at the rear of the engine and, on V6 engines, just below the throttle body (see illustrations). Later (1992 onward) 4-cylinder engines don't have a bleed screw.
- 16 Slowly fill the system through the

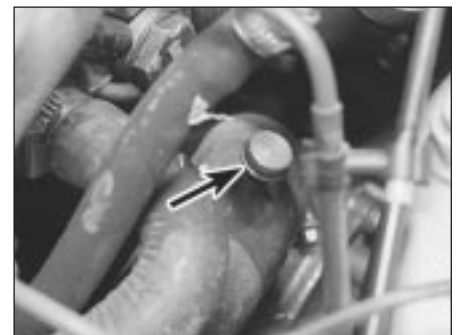

38.15a Cooling system bleed screw location (arrowed) on early 4-cylinder engines . . .



## 1•26 Every 24 000 miles

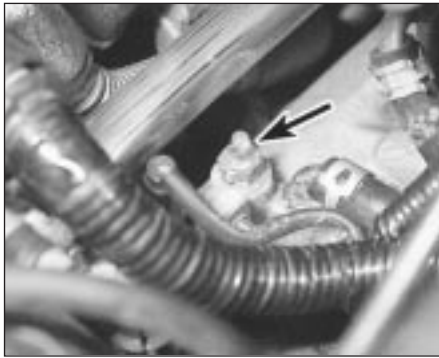

38.15b . . . and on V6 engines (arrowed)

expansion tank until coolant, free from air bubbles, flows from the bleed screw. Tighten the bleed screw and continue filling until the coolant level reaches the expansion tank "MAX" level line.

17 Start the engine, run it for approximately two minutes, then switch off.

18 Slowly unscrew the pressure cap one complete turn, wait until all the pressure escapes, then remove the cap. Check that the coolant just covers the pipe outlet on the seam of the tank, top up if necessary, then refit the cap.

19 After refilling, always check carefully all components of the system (but especially any unions disturbed during draining and flushing) for signs of coolant leaks. Fresh antifreeze has a searching action, which will rapidly expose any weak points in the system.

20 **Note:** *If, after draining and refilling the system, symptoms of overheating are found which did not occur previously, then the fault is almost certainly due to trapped air at some point in the system, causing an air-lock and restricting the flow of coolant; usually, the air is trapped because the system was refilled too quickly. In some cases, air-locks can be released by tapping or squeezing the various hoses. If the problem persists, stop the engine and allow it to cool down completely, before unscrewing the expansion tank filler cap or disconnecting hoses to bleed out the trapped air.*

### Antifreeze mixture

21 The cooling system should be filled with a water/ethylene glycol-based antifreeze solution, of a strength which will prevent freezing down to at least -25°C, or lower if the local climate requires it. Antifreeze also protects against corrosion, and increases the coolant boiling point.

22 Before adding antifreeze, the cooling

system should be completely drained, preferably flushed, and all hoses checked for condition and security. As noted earlier, fresh antifreeze will rapidly find any weaknesses in the system.

23 After filling with antifreeze, a label should be attached to the expansion tank, stating the type and concentration of antifreeze used, and the date installed. Any subsequent topping-up should be made with the same type and concentration of antifreeze.

24 The exact mixture of antifreeze-to-water which you should use depends on the relative weather conditions. On all V6 engines, and 4-cylinder engines equipped with air conditioning, the mixture should contain approximately 50% antifreeze. On 4-cylinder engines without air conditioning, approximately a 33% antifreeze mixture is recommended. Antifreeze concentrations greater than 55% for V6 engines or 60% for 4-cylinder engines are not recommended as the efficiency of the cooling system may be impaired. Consult the mixture ratio chart on the antifreeze container before adding coolant. Hydrometers are available at most automotive accessory shops to test the coolant. Use antifreeze which meets the vehicle manufacturer's specifications.

## Every 48 000 miles

### 39 Timing belt renewal



1 As mentioned in Section 32, the

manufacturers have increased the service interval for checking the timing belt condition and tension on certain engines, and also the renewal interval. On certain engines the renewal interval is every 48 000 miles but, according to the manufacturer's, the timing

belt on 1990 model year onward V6 engines should last for 96 000 miles. Prudent owners may wish to reduce this interval considerably.

2 Refer to Chapter 2, Part A, or Part B as applicable for renewal procedures

## Every 60 000 miles or 5 years, whichever occurs first

### 40 Braking system hydraulic fluid seal check and renewal



Refer to the relevant overhaul procedures in Chapter 9, for the brake calipers and master cylinder.

### 41 Emissions control equipment check



1 Details of the emissions control system components are given in Chapter 4 Part E, and checking procedures for the positive

crankcase ventilation system is given in Section 33 of this Chapter.

2 Checking and testing of the other emissions control systems should be entrusted to a Rover dealer.







# Chapter 2 Part A: 4-cylinder engine – in-car engine repair procedures

## Contents

Auxiliary drivebelts check and renewal . . . . .	See Chapter 1	Exhaust manifold - removal and refitting . . . . .	6
Camshafts and hydraulic tappets - removal, inspection and refitting . . . . .	11	Flywheel/driveplate - removal, inspection and refitting . . . . .	17
Camshaft covers - removal and refitting . . . . .	4	General information . . . . .	1
Camshaft oil seals - renewal . . . . .	10	Inlet manifold - removal and refitting . . . . .	5
Compression test - description and interpretation . . . . .	3	Oil pump - dismantling, inspection and reassembly . . . . .	15
Crankshaft oil seals - renewal . . . . .	16	Oil pump - removal and refitting . . . . .	14
Cylinder head - removal and refitting . . . . .	12	Repair operations possible with the engine in the vehicle . . . . .	2
Cylinder head, rocker gear and valve assemblies - cleaning and inspection . . . . .	See Chapter 2C	Spark plug renewal . . . . .	See Chapter 1
Engine oil and filter change . . . . .	See Chapter 1	Sump - removal and refitting . . . . .	13
Engine oil level check . . . . .	See Chapter 1	Timing belt ("M" series) - removal, refitting and adjustment . . . . .	7
Engine overhaul - general information . . . . .	See Chapter 2C	Timing belt ("T" series) - removal, refitting and adjustment . . . . .	8
Engine/transmission - removal and refitting . . . . .	See Chapter 2C	Timing belt tensioner and sprockets - removal, inspection and refitting . . . . .	9
Engine/transmission mountings - inspection and renewal . . . . .	18	Water pump - removal and refitting . . . . .	See Chapter 3

## Degrees of difficulty

<b>Easy</b> , suitable for novice with little experience 	<b>Fairly easy</b> , suitable for beginner with some experience 	<b>Fairly difficult</b> , suitable for competent DIY mechanic 	<b>Difficult</b> , suitable for experienced DIY mechanic 	<b>Very difficult</b> , suitable for expert DIY or professional 
---	--	--	---	--

## Specifications

### General

Engine type . . . . .	Four-cylinder, in-line, double-overhead camshafts
Engine codes:	
"M" series engines:	
Normally aspirated engines . . . . .	M16 (20 HD)
Turbocharged engines . . . . .	M16 (20 M4G)
"T" series engines:	
Normally aspirated engines . . . . .	T16 (20 T4)
Turbocharged engines . . . . .	T16 (20 T4) Turbo
Capacity . . . . .	1994 cc
Bore . . . . .	84.45 mm
Stroke . . . . .	89.0 mm
Compression ratio:	
Normally aspirated engines . . . . .	10.0:1
Turbocharged engines . . . . .	8.5:1
Firing order . . . . .	1-3-4-2 (No 1 cylinder at timing belt end)
Direction of crankshaft rotation . . . . .	Clockwise (seen from right-hand side of vehicle)
Timing belt tensioner spring free length ("T" series engines) . . . . .	57.5 to 58.5 mm

### Cylinder head

Maximum gasket face distortion . . . . .	0.1 mm
--	--------

### Camshafts and hydraulic tappets

Camshaft bearing running clearance:	
New . . . . .	0.060 to 0.094 mm
Used . . . . .	0.15 mm maximum
Camshaft endfloat ("T" series engines) . . . . .	0.06 to 0.25 mm

### Lubrication

Engine oil type/specification . . . . .	See Chapter 1
Engine oil capacity . . . . .	See Chapter 1
Oil pressure:	
Idling . . . . .	0.7 bar
Running . . . . .	3.8 bar

## 2A•2 4-cylinder engine – in-car engine repair procedures

<b>Torque wrench settings</b>	<b>Nm</b>	<b>lbf ft</b>
Camshaft cover bolts:		
"M" series engines	10	7
"T" series engines	8	6
Camshaft sprocket bolts	65	48
Camshaft housing bolts	25	18
Timing belt tensioner bolt:		
"M" series engines	45	33
"T" series engines	30	22
Timing belt idler pulley bolt ("M" series engines):		
Up to 1989	25	18
1989 onwards	50	36
Cylinder head bolts ("M" series engines):		
Up to 1989:		
Stage 1	45	33
Stage 2	80	59
Stage 3	Angle-tighten a further 60°, or to 108 Nm (80 lbf ft) whichever comes first	
1989 onwards:		
Stage 1	45	33
Stage 2	80	59
Stage 3	Angle-tighten a further 90°	
Cylinder head bolts ("T" series engines):		
With MSPS stamped on bolt head:		
Stage 1	45	33
Stage 2	80	59
Stage 3	Angle-tighten a further 90°	
With KX stamped on bolt head:		
Stage 1	45	33
Stage 2	70	52
Stage 3	Angle-tighten a further 90°	
Inlet manifold nuts and bolts	25	18
Exhaust manifold nuts and bolts	45	33
Crankshaft pulley centre bolt	85	63
Crankshaft pulley-to-sprocket bolts	8	6
Oil pump housing bolts ("M" series engines)	6	4
Oil pump housing bolts ("T" series engines):		
M6 bolts	8	6
M10 bolts	45	33
Oil pump cover plate	6	4
Oil pick-up pipe-to-pump screws	8	6
Sump bolts:		
"M" series engines	8	6
"T" series engines:		
Stage 1	5	3
Stage 2	10	7
Flywheel bolts:		
"M" series engines	85	63
"T" series engines	110	81
Torque converter driveplate bolts	110	81
Transmission adaptor plate bolts:		
"M" series engines:		
Bolts below crankshaft centre-line	25	18
Bolts above crankshaft centre-line	45	33
"T" series engines	45	33
Rear oil seal carrier bolts	8	6
Main bearing cap	110	81
Crankpin (big-end) bearing cap bolts	55	41
Front engine mounting to transmission bracket	80	59
Front engine mounting bracket to transmission	40	30
Rear engine mounting bracket to transmission	40	30
Right-hand engine mounting through-bolt	45	33
Right-hand engine mounting to engine bracket	60	44
Right-hand engine mounting bracket to engine	25	18
Engine rear tie-bar to mounting bracket	75	55
Engine rear tie-bar mounting bracket bolts:		
M10 bolts	45	33
M12 bolts	85	63
Engine rear tie-bar through-bolt	85	63
Longitudinal support member to underbody	45	33
Engine snubber bracket to transmission	45	33

## 1 General information

### How to use this Chapter

1 This Part of Chapter 2 is devoted to repair procedures possible while the engine is still installed in the car, and includes only the Specifications relevant to those procedures. Similar information concerning the V6 engines will be found in Part B of this Chapter. Since these procedures are based on the assumption that the engine is installed in the car, if the engine has been removed and mounted on a stand, some of the preliminary dismantling steps outlined will not apply.

2 Information concerning engine/transmission removal and refitting, and engine overhaul, can be found in Part C of this Chapter, which also includes the Specifications relevant to those procedures.

### Engine description

#### "M" series engine

3 The M16 engine fitted to Rover 820 models is a water-cooled, four-cylinder, double-overhead camshaft, four-stroke petrol engine, of 1994 cc capacity. The engine was fitted to Rover 820 models from 1986 until approximately October 1991.

4 The combined crankcase and cylinder block is of cast iron construction, and houses the pistons, connecting rods and crankshaft. The solid skirt cast aluminium alloy pistons have two compression rings and an oil control ring, and are retained on the connecting rods by fully floating gudgeon pins. To reduce frictional drag and piston slap, the gudgeon pin is offset to the thrust side of the piston. The forged steel connecting rods are attached to the crankshaft by renewable shell type big-end bearings. The crankshaft is carried in five main bearings, also of the renewable shell type. Crankshaft endfloat is controlled by thrust washers which are located on either side of the centre main bearing.

5 The twin overhead camshafts are located in the cylinder head, and each is retained in position by a housing bolted to the cylinder head upper face. The camshafts are supported by five bearing journals machined directly into the head and housings. Drive to the camshafts is by an internally-toothed rubber timing belt, from a sprocket on the front end of the crankshaft. An idler pulley and adjustable tensioner pulley are fitted to eliminate backlash and prevent slackness of the belt. The distributor rotor arm is attached to the rear of the exhaust camshaft, and on early models, the power steering pump is belt-driven from a sprocket attached to the rear of the inlet camshaft. On later models, the power steering is located at the front of the engine, and is belt-driven from a sprocket on the crankshaft.

6 The M16 engine utilizes four valves per cylinder, mounted at an inclined angle, and running in guides which are pressed into the cylinder head. The valves are of small diameter, to improve breathing efficiency and reduce valve mass. Each valve is opened by a hydraulic tappet, acted upon directly by the lobe of the camshaft, and closed by a single valve spring.

7 Blow-by gases from the crankcase are vented by a positive crankcase ventilation system back into the intake air stream for combustion. The system incorporates an oil separator, to return oil droplets to the sump, and a diverter valve, which channels the vapour to inlets on either side of the throttle valve, depending on manifold depression.

8 The pressed-steel sump is attached to the underside of the crankcase, and acts as a reservoir for the engine oil. The oil pump draws oil through a strainer attached to the pick-up pipe and submerged in the oil. The pump passes the oil along a short passage and into the full-flow filter, which is screwed onto the pump housing. The freshly filtered oil flows from the filter and enters the main cylinder block oil gallery, which feeds the crankshaft main bearings. Oil passes from the main bearings, through drillings in the crankshaft to the big-end bearings.

9 As the crankshaft rotates, oil is squirted from a hole in each connecting rod, to splash the thrust side of the pistons and cylinder bores.

10 A drilling from the main oil gallery feeds the cylinder head gallery, via a restrictor located just below the top face of the cylinder block. The cylinder head contains an oil gallery on each side, with drillings to lubricate each camshaft journal and hydraulic tappet bore. The oil then drains back into the sump via large drillings in the cylinder head and cylinder block.

11 On turbocharged engines, a take-off pipe from the main oil gallery feeds the turbocharger shaft bearings and then returns to the sump via an oil return pipe.

12 A pressure relief valve is incorporated in the oil pump housing, to maintain the oil pressure within specified limits.

#### "T" series engine

13 The T16 engine fitted to later Rover 820 and Vitesse models is a development of the "M" series unit and is similar in most areas. The engine was fitted to Rover 820 models from approximately October 1991 and is currently still in production.

14 The main differences between the two units is in the following areas.

15 The timing belt only drives the two camshafts; the water pump now being situated externally on the engine, behind the power steering pump, and driven (in conjunction with the power steering pump) by the auxiliary drive belt. The timing belt incorporates an automatic tensioner to maintain correct timing belt tension for virtually the life of the belt.

16 The semi-floating pistons are retained on the connecting rods by interference fit gudgeon pins.

17 The engine mountings have been revised to improve vibration resistance and power unit stability.

18 Other detail modifications have been incorporated, mainly in the area of ancillary component attachments, and these will be covered in greater detail where procedures in this Chapter are likely to be affected.

## 2 Repair operations possible with the engine in the vehicle

The following operations can be carried out without having to remove the engine from the car:

- (a) Compression pressure - testing.
- (b) Removal and refitting of the timing belt.
- (c) Removal and refitting of the camshaft and tappets.
- (d) Removal and refitting of the cylinder head.
- (e) Removal and refitting of the sump.
- (f) Removal and refitting of the big-end bearings.\*
- (g) Removal and refitting of the piston and connecting rod assemblies.\*
- (h) Removal and refitting of the oil pump.
- (i) Removal and refitting of the engine mountings.
- (j) Removal and refitting of the flywheel or driveplate (after first removing the transmission).

\* In extreme cases caused by a lack of necessary equipment, repair or renewal of piston rings, pistons, connecting rods and big-end bearings is possible with the engine in the vehicle. However, this practice is not recommended, because of the cleaning and preparation work that must be done to the components involved, and because of the amount of preliminary dismantling work required - these operations are therefore covered in Part C of this Chapter.

## 3 Compression test - description and interpretation



1 When engine performance is down, or if misfiring occurs which cannot be attributed to the ignition or fuel systems, a compression test can provide diagnostic clues as to the engine's condition. If the test is performed regularly, it can give warning of trouble before any other symptoms become apparent.

2 The engine must be fully warmed-up to normal operating temperature, the oil level must be correct, the battery must be fully charged, and the spark plugs must be removed. The aid of an assistant will also be required.

## 2A•4 4-cylinder engine – in-car engine repair procedures

3 Disable the ignition system by disconnecting the LT wiring connectors from the ignition coil. Refer to Chapter 5 for further information.

4 Fit a compression tester to the No 1 cylinder spark plug hole - the type of tester which screws into the plug thread is to be preferred.

5 Arrange for an assistant to hold the accelerator pedal fully depressed to the floor while at the same time cranking the engine over several times on the starter motor. Observe the compression gauge reading. The compression will build up fairly quickly in a healthy engine. Low compression on the first stroke, followed by gradually increasing pressure on successive strokes indicates worn piston rings. A low compression on the first stroke which does not rise on successive strokes, indicates leaking valves or a blown head gasket (a cracked cylinder head could also be the cause). Deposits on the underside of the valve heads can also cause low compression. Record the highest gauge reading obtained, then repeat the procedure for the remaining cylinders.

6 Due to the variety of testers available, and the fluctuation in starter motor speed when cranking the engine, different readings are often obtained when carrying out the compression test. However, the most important factor is that the compression pressures are uniform in all cylinders, and that is what this test is mainly concerned with.

7 Add some engine oil (about three squirts

from a plunger type oil can) to each cylinder through the spark plug holes and repeat the test.

8 If the compression increases after the oil is added it is indicative that the piston rings are definitely worn. If the compression does not increase significantly, the leakage is occurring at the valves or the head gasket. Leakage past the valves may be caused by burned valve seats and/or faces or warped, cracked or bent valves.

9 If two adjacent cylinders have equally low compressions, it is most likely that the head gasket has blown between them. The appearance of coolant in the combustion chambers or crankcase would verify this condition.

10 If one cylinder is about 20 percent lower than the other, and the engine has a rough idle, a worn lobe on the camshaft could be the cause.

11 On completion of the checks, refit the spark plugs and reconnect the LT wiring at the ignition coil.

### 4 Camshaft covers - removal and refitting



#### "M" series engines

##### Removal

1 Detach the breather hose from the rear of the inlet camshaft cover.

2 On cars with multi-point fuel injection, release the plastic covers then undo the two bolts securing the plenum chamber support brackets to the plenum chamber.

3 Undo the two bolts and lift off the spark plug cover from the centre of the cylinder head. Note that the spark plug HT lead grommet engages with the end of the cover, and on certain models, an accelerator cable support bracket is also retained by the right-hand cover bolt.

4 Undo the ten bolts securing each camshaft cover to its respective camshaft housing, and lift off the two covers (see illustrations).

5 Withdraw the baffle plates, taking care not to damage the sealing edges on both sides of the plates (see illustration).



4.4a Undo the camshaft cover retaining bolts . . .



4.4b . . . and remove the covers

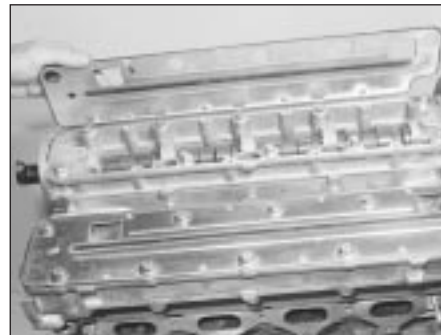

4.5 Remove the baffle plates over the camshafts

##### Refitting

6 Refitting is a reversal of removal. Renew the baffle plates if their sealing edges are damaged. Tighten the bolts to the specified torque.

#### "T" series engines

##### Removal

7 Detach the breather hoses from the side and rear of the inlet camshaft cover.

8 Undo the two bolts securing the plenum chamber support brackets to the plenum chamber.

9 Undo the four screws and lift off the spark plug cover between the two camshaft covers.

10 Working from the centre outwards slacken then remove the ten bolts (inlet camshaft cover), or 12 bolts (exhaust camshaft cover) and lift off the two covers.

11 Withdraw the baffle plates, taking care not to damage the sealing edges on both sides of the plates.

##### Refitting

12 Refitting is a reversal of removal. Renew the baffle plates if their sealing edges are damaged. Tighten the cover bolts to the specified torque in the sequence shown (see illustration).

### 5 Inlet manifold - removal and refitting



**Warning:** Petrol is extremely flammable, so take extra precautions when disconnecting any part of the fuel system.

*Don't smoke, or allow naked flames or bare light bulbs in or near the work area. Don't work in a garage where a natural gas appliance (such as a clothes dryer or water heater) is installed. If you spill petrol on your skin, rinse it off immediately. Have a fire extinguisher rated for petrol fires handy, and know how to use it.*

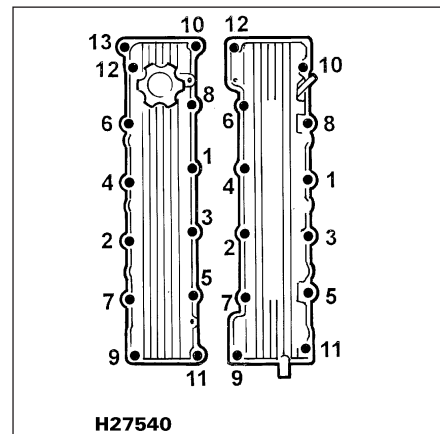

4.12 Camshaft cover tightening sequence for "T" series engines





5.4 Release the hose clips and disconnect the two hoses from the fuel pipes



5.7 Undo the brake servo banjo hose union at the manifold



5.8 Disconnect the coolant hose from the right-hand end of the manifold

### Single-point fuel injection engines

#### Removal

- 1 Disconnect the battery negative (earth) lead (refer to Chapter 5, Section 1).
- 2 Refer to Chapter 4A, and remove the air cleaner air box.
- 3 Relieve the fuel system pressure as described in Chapter 4A, Section 5.
- 4 Release the hose clips and disconnect the two fuel hoses from the fuel pipes (see illustration).
- 5 Refer to Chapter 4A, Section 12, and remove the throttle body.
- 6 Refer to Chapter 1 and drain the cooling system.
- 7 Undo the brake servo banjo hose union at the manifold, and recover the two copper washers (see illustration).
- 8 Slacken the hose clip and disconnect the coolant hose from the right-hand end of the manifold (see illustration).
- 9 Disconnect the vacuum hoses from the left-hand end of the manifold, after noting their respective positions for reassembly.
- 10 Slacken the hose clip and disconnect the remaining coolant hose from the manifold.
- 11 Undo the bolt securing the manifold to the support bracket under the coolant hose outlet.
- 12 Undo the bolt securing the upper end of the stay bar to the manifold.
- 13 Apply the handbrake, jack up the front of the car and support it on axle stands.

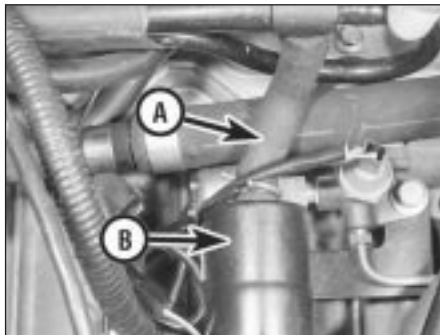

5.15 Disconnect the breather hose (A) from the oil separator (B)



5.20 Disconnect the leads at the manifold heater temperature sensor

- 14 Undo the manifold stay bar lower retaining bolt and remove the stay (see illustration).
- 15 Release the clip and disconnect the breather hose from the oil separator (see illustration).
- 16 Disconnect the breather hose from the lower end of the oil separator at the cylinder block, and at the sump outlet.
- 17 Disconnect the lead at the oil pressure switch and disconnect the pressure transducer lead at the wiring connector.
- 18 Unscrew the pipe union nut at the oil pressure switch adaptor.
- 19 Unscrew the bolt securing the oil pressure switch adaptor and oil separator to the cylinder block and remove the adaptor and oil separator.
- 20 Disconnect the wiring plug at the knock sensor on the cylinder block, and the two leads at the manifold heater temperature sensor under the manifold (see illustration). Move the wiring harness clear of the manifold.
- 21 Slacken the nine nuts and bolts securing the manifold to the cylinder head.
- 22 Remove all the bolts followed by the two nuts, then withdraw the manifold off the studs and remove it from the engine. Recover the manifold gasket.
- 23 Clean the manifold and cylinder head mating faces, and obtain a new gasket if the sealing lips of the original are damaged.

#### Refitting

- 24 Refitting is a reversal of removal; tighten

the manifold nuts and bolts in the sequence shown, to the specified torque (see illustration).

### Multi-point fuel injection engines

#### Removal

- 25 Remove the fuel injectors and fuel rail as described in Section 12 of either Chapter 4B, for "M" series, or Chapter 4C for "T" series.
- 26 Release the clip and disconnect the breather hose from the oil separator.
- 27 Disconnect the breather hose from the lower end of the oil separator and the sump outlet.
- 28 Disconnect the wires at the oil pressure switch, oil pressure transducer and knock sensor.



5.14 Undo the manifold stay bar lower retaining bolt (arrowed)

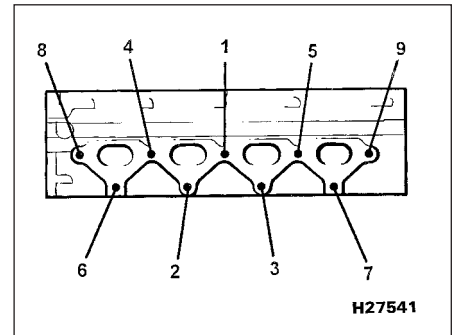

5.24 Inlet manifold nut and bolt tightening sequence



6.8a Undo the bolts securing the two halves of the manifold stove . . .



6.8b . . . and remove the stove outer half

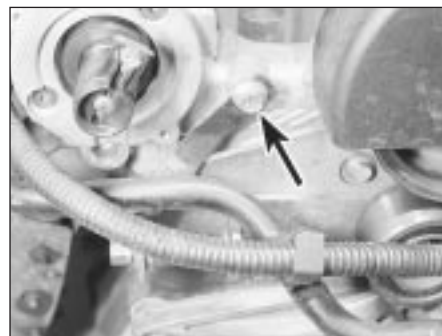

6.9a Undo the bolt securing the bypass pipe to the cylinder head (arrowed) . . .

29 Slacken the nine nuts and bolts securing the manifold to the cylinder head.

30 Remove all the bolts, followed by the two nuts, then withdraw the manifold off the studs and remove it from the engine. Recover the manifold gasket.

31 Clean the manifold and cylinder head mating faces, and obtain a new gasket if the sealing lips of the original are damaged.

#### Refitting

32 Refitting is a reversal of removal; tighten the manifold nuts and bolts in the sequence shown, to the specified torque (see illustration 5.24).

provide access to the front and side of the engine.

3 Drain the cooling system as described in Chapter 1.

4 Remove the dipstick from the dipstick tube.

5 Remove the distributor cap and place it to one side.

6 Apply the handbrake, jack up the front of the car and support it on axle stands.

7 Undo the four bolts securing the exhaust front pipe flange to the manifold. Separate the flange and recover the gasket.

8 Undo the bolts on both sides securing the two halves of the manifold stove together, and remove the outer half (see illustrations).

9 Undo the bolt securing the heater bypass pipe to the cylinder head and to the main coolant pipe support bracket (see illustrations).

10 Slacken the clip securing the bypass pipe connecting hose to the thermostat housing.

11 Undo the five nuts and bolts securing the manifold to the cylinder head, noting that the upper nut also secures the bypass pipe bracket (see illustration).

12 Release the connecting hose from the thermostat housing, and withdraw the bypass pipe from the manifold stud.

13 Remove the manifold from the cylinder head, followed by the inner half of the stove and the manifold gasket.

14 Clean the manifold and cylinder head mating faces, and obtain a new gasket if the original is damaged.

#### Refitting

15 Refitting is a reversal of removal; tighten the manifold nuts and bolts starting with the upper two, then the lower centre, then the two outer, to the specified torque. Make sure that the inner half of the stove is in position before fitting the manifold.

#### Multi-point fuel injection engines

##### Normally-aspirated engines

16 Refer to the procedures described above for single-point fuel injection engines, but ignore the instructions to remove the manifold stove, which is not fitted to models with multi-point fuel injection.

##### Turbocharged engines

17 Refer to Chapter 4B or 4C as applicable and remove the turbocharger.

18 Refer to the procedures described above for single-point fuel injection engines, but ignore the instructions to remove the manifold stove, which is not fitted to models with multi-point fuel injection.

## 6 Exhaust manifold - removal and refitting



**Note:** Never work on or near a hot exhaust system and in particular, the catalytic converter (where fitted).

### Single-point fuel injection engines

#### Removal

1 Disconnect the battery negative (earth) lead (refer to Chapter 5, Section 1).

2 Refer to Chapter 4A, Section 2, and remove the necessary air cleaner components to

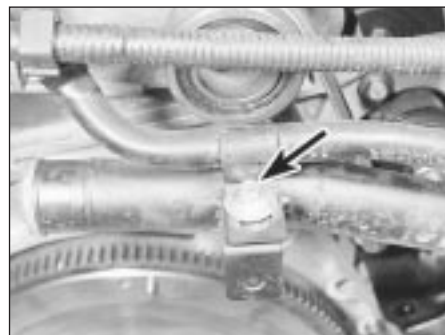

6.9b . . . and to the main coolant pipe bracket (arrowed)



6.11 Undo the manifold nuts and bolts, noting that the upper nut also secures the bypass pipe bracket

## 7 Timing belt ("M" series) - removal, refitting and adjustment



**Note:** Accurate adjustment of the timing belt entails the use of a tension checking gauge which is a Rover special tool. An approximate setting can be achieved using the method described in this Section, but the tension should be checked by a Rover dealer on completion.

**Note:** On early "M" series engines the crankshaft pulley and timing belt sprocket are a one-piece assembly secured by a single centre bolt. On later "M" series engines (with a front mounted power steering pump), the pulley and sprocket are two separate components secured by the centre retaining bolt and four additional bolts. As this difference significantly affects the timing belt procedures, identify the type being worked on before proceeding.



7.6 Undo the bolts securing the power steering pipe support brackets (arrowed)



7.7 Undo the engine right-hand mounting through-bolt

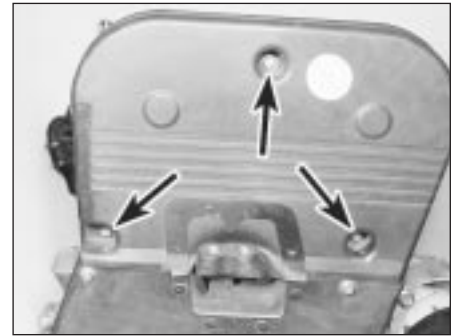

7.9 Timing belt upper cover retaining bolts (arrowed)

### Early "M" series engines

#### Removal

- 1 Disconnect the battery negative (earth) lead (refer to Chapter 5, Section 1).
- 2 Slacken the right-hand front wheel nuts, jack up the front of the car and support it on axle stands. Remove the roadwheel.
- 3 Undo the three bolts and remove the access panel under the wheelarch.
- 4 Refer to Chapter 1 and remove the auxiliary drivebelt.
- 5 Position a jack and interposed block of wood under the sump, and just take the weight of the engine.
- 6 Undo the bolts securing the power steering pipe support brackets, and move the pipes

slightly to gain access to the right-hand engine mounting (see illustration).

7 Undo the engine mounting through-bolt, and recover the special nut. Note that the forked end of the nut plate locates over a stud on the body bracket (see illustration).

8 Undo the two bolts securing the engine mounting to its mounting bracket, and remove the mounting.

9 Raise the engine slightly, then undo the three bolts and lift off the timing belt upper cover (see illustration).

10 Undo the four bolts and remove the timing belt lower cover (see illustration).

11 Using a socket or spanner on the crankshaft pulley, turn the crankshaft in an anti-clockwise direction until the timing

notches on the camshaft sprockets are facing each other and aligned horizontally (see illustrations). The notch on the crankshaft pulley should also be aligned with the edge of the metal bracket which forms the timing belt bottom cover (see illustration). In this position, the crankshaft is at 90° BTDC, with No 1 piston on its compression stroke.

12 If required, the crankshaft can be locked in this position, by inserting a dowel rod or drill through the hole in the transmission adaptor plate, near to the lower edge of the cylinder block on the front-facing side of the engine (see illustration). The dowel or drill will then engage with a corresponding hole in the flywheel.

13 Undo the three bolts and remove the timing belt bottom cover (see illustration).

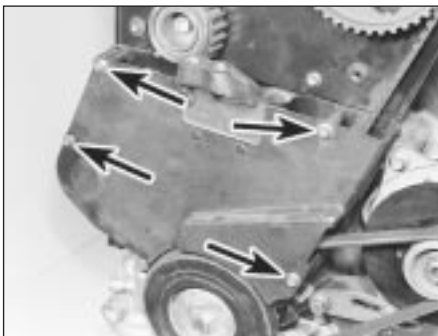

7.10 Timing belt lower cover retaining bolts (arrowed)

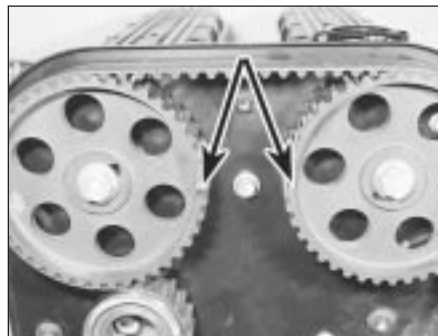

7.11a Turn the crankshaft to align the sprocket timing marks (arrowed) . . .

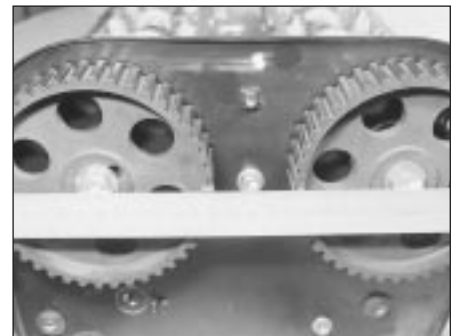

7.11b . . . then check their horizontal alignment with a straight edge

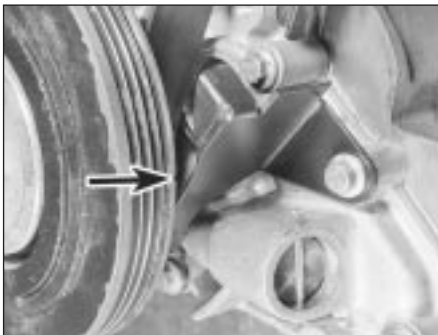

7.11c Crankshaft pulley timing notch (arrowed) aligned with timing belt bottom cover

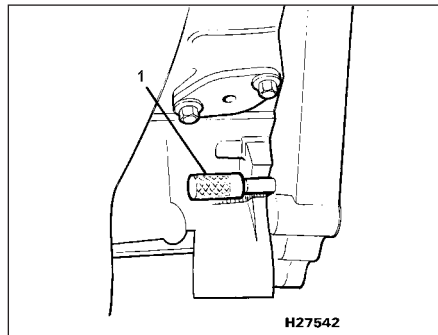

7.12 Lock the crankshaft by inserting a dowel rod or drill (1) through the hole in the transmission adaptor plate



7.13 Removing the timing belt bottom cover





7.14 Removing the timing belt tensioner

14 Using an Allen key, undo the timing belt tensioner retaining bolt, and remove the tensioner (**see illustration**).

15 Slip the belt off the sprockets, and remove it from the engine.

16 If the timing belt is to be re-used, mark its running direction with an arrow in chalk, and store it on its edge while it is off the engine.

17 Check the belt for any sign of cracks or splits, particularly around the roots of the teeth. Renew the belt if wear is obvious, if there are signs of oil contamination, or if the belt has exceeded its service interval (see Chapter 1). Also renew the sprockets if they show any signs of wear or chipping of the teeth.

18 Check the tensioner and sprockets as described in Section 9.

19 Before refitting, check that the crankshaft is still at the 90° BTDC position, and that the timing marks on the two sprockets are still aligned.

### Refitting and adjustment

20 Engage the timing belt with the teeth of the crankshaft sprocket, and then pull the belt vertically upright on its straight, right-hand run. Keep it taut, and engage it over the exhaust camshaft sprocket, then the inlet camshaft sprocket.

21 Check that none of the sprockets have moved, then feed the belt around the idler pulley and engage it with the teeth of the water pump sprocket.

22 Fit the timing belt tensioner and secure with the retaining bolt, tightened finger-tight only at this stage.

23 Engage an Allen key with the hexagonal adjusting hole in the tensioner, and turn the tensioner body until there is moderate tension on the belt (**see illustration**). Hold the tensioner in this position, and tighten the retaining bolt.

24 Remove the locking pin (if used) from the transmission adaptor plate, and turn the crankshaft one complete turn clockwise, followed by one complete turn anti-clockwise, and re-align the timing marks.

25 Check that it is just possible to deflect the belt, using moderate hand pressure, by 19.0 mm at a point midway between the crankshaft and exhaust camshaft sprockets.



7.23 Tensioner hexagonal adjusting hole (arrowed)

Re-adjust the tension if necessary by slackening the tensioner retaining bolt, and repositioning the tensioner body with the Allen key. Recheck the tension again after turning the crankshaft one turn clockwise, then one turn anti-clockwise. It must be emphasised that this is only an approximate setting, and the tension should be checked by a dealer, using the Rover tension gauge, at the earliest opportunity.

26 Refit the timing belt bottom cover, turn the crankshaft to align the pulley timing mark with the edge of the bottom cover, and make a final check that the camshaft sprocket timing marks are still aligned.

27 Refit the timing belt upper and lower covers.

28 Refit the engine mounting to its bracket, lower the engine and secure the mounting to the body with the through-bolt and special nut.

29 Refer to Chapter 1 and refit the auxiliary drivebelt.

30 Refit the power steering pipe support brackets, the wheelarch access panel, and the roadwheel.

31 Lower the car to the ground, tighten the wheel nuts fully, and reconnect the battery.

### Later "M" series engines

#### Removal

32 Proceed as described in paragraphs 1 to 9 above.

33 Undo the four bolts and remove the timing belt centre cover.

34 Using a socket or spanner on the crankshaft pulley, turn the crankshaft in an anti-clockwise direction until the notches on the camshaft sprockets are facing each other and aligned horizontally. Insert a dowel rod or drill through the hole in the transmission adaptor plate, near to the lower edge of the cylinder block on the front-facing side of the engine (**see illustration 7.12**). The dowel or drill will then engage with a corresponding hole in the flywheel. If the dowel won't engage, turn the crankshaft through 180° and try again. With the dowel rod engaged and the camshaft notches aligned, the crankshaft is at 90° BTDC, with No 1 piston on its compression stroke. Temporarily remove the dowel rod.

35 Refer to Chapter 5, and remove the starter motor.

36 Using a socket and long handle, slacken the crankshaft pulley centre retaining bolt. Lock the flywheel ring gear, through the starter motor aperture, using a large screwdriver or similar tool to prevent the crankshaft rotating as the pulley bolt is undone. This operation will probably have moved the timing marks on the camshafts out of alignment, so re-align them, and fit the crankshaft dowel rod as described previously.

37 Remove the centre retaining bolt from the crankshaft pulley, then unscrew the four additional pulley bolts and remove the pulley.

38 Undo the bolts and remove the timing belt bottom cover.

39 Using an Allen key, undo the timing belt tensioner retaining bolt, and remove the tensioner.

40 Slip the belt off the sprockets, and remove it from the engine.

41 Check the timing belt, sprockets and tensioner as described in paragraphs 16 to 18.

42 Before refitting, check that the crankshaft is still at the 90° BTDC position, and that the timing marks on the two sprockets are still aligned.

### Refitting and adjustment

43 Engage the timing belt with the teeth of the crankshaft sprocket, and then pull the belt vertically upright on its straight, right-hand run. Keep it taut, and engage it over the exhaust camshaft sprocket, then the inlet camshaft sprocket.

44 Check that none of the sprockets have moved, then feed the belt around the idler pulley and engage it with the teeth of the water pump sprocket.

45 Fit the timing belt tensioner and secure with the retaining bolt, tightened finger-tight only at this stage.

46 Refit the timing belt bottom cover.

47 Remove the dowel rod from the crankshaft.

48 Refit the crankshaft pulley and secure with the centre bolt and four additional bolts, tightened to the specified torque. Hold the crankshaft using the same procedure as for removal to tighten the centre bolt.

49 Engage an Allen key with the hexagonal adjusting hole in the tensioner, and turn the tensioner body until there is moderate tension on the belt. Hold the tensioner in this position, and tighten the retaining bolt.

50 Turn the crankshaft one complete turn clockwise, followed by one complete turn anti-clockwise, and re-align the timing marks.

51 Check that it is just possible to deflect the belt, using moderate hand pressure, by 19.0 mm at a point midway between the crankshaft and exhaust camshaft sprockets. Re-adjust the tension if necessary by slackening the tensioner retaining bolt, and repositioning the tensioner body with the Allen key. Recheck the tension again after turning



the crankshaft one turn clockwise, then one turn anti-clockwise. It must be emphasised that this is only an approximate setting, and the tension should be checked by a dealer, using the Rover tension gauge, at the earliest opportunity.

52 The remainder of refitting is a reversal of removal.

## 8 Timing belt ("T" series) - removal, refitting and adjustment



### Removal

1 Disconnect the battery negative (earth) lead (refer to Chapter 5, Section 1).

2 Slacken the right-hand front wheel nuts, jack up the front of the car and support it on axle stands. Remove the roadwheel.

3 Undo the three bolts and remove the access panel under the wheelarch.

4 Refer to Chapter 1 and remove the auxiliary drivebelt.

5 Position a jack and interposed block of wood under the sump, and just take the weight of the engine.

6 Undo the bolts securing the power steering pipe support brackets, and move the pipes slightly to gain access to the right-hand engine mounting.

7 Undo the engine mounting through-bolt, and recover the special nut. Note that the forked end of the nut plate locates over a stud on the body bracket.

8 Undo the two bolts securing the engine mounting to its mounting bracket, and remove the mounting.

9 Raise the engine slightly, then undo the five bolts and lift off the timing belt upper cover (see illustration).

10 Undo the remaining five bolts and remove the timing belt centre cover.

11 Using a socket or spanner on the crankshaft pulley, turn the crankshaft in an anti-clockwise direction until the timing notches on the camshaft sprockets are facing each other and aligned horizontally. Insert a dowel rod or drill through the hole in the transmission adaptor plate, near to the lower edge of the cylinder block on the front-facing side of the engine (see illustration 7.12). The dowel or drill will then engage with a corresponding hole in the flywheel. If the dowel won't engage, turn the crankshaft through 180° and try again.

12 With the dowel rod engaged and the camshaft notches aligned, the crankshaft is at 90° BTDC, with No 1 piston on its compression stroke. Temporarily remove the dowel rod.

13 Refer to Chapter 5, and remove the starter motor.

14 Using a socket and long handle, slacken the crankshaft pulley centre retaining bolt. Lock the flywheel ring gear, through the starter motor aperture, using a large

screwdriver or similar tool to prevent the crankshaft rotating as the pulley bolt is undone. This operation will probably have moved the timing marks on the camshafts out of alignment, so re-align them, and fit the crankshaft dowel rod as described previously.

15 Remove the centre retaining bolt from the crankshaft pulley, then unscrew the four additional pulley bolts and remove the pulley.

16 Undo the three bolts and remove the timing belt bottom cover.

17 Slacken the timing belt tensioner centre bolt, move the tensioner away from the belt as far as it will go, then re-tighten the tensioner bolt.

18 Slip the belt off the sprockets, and remove it from the engine.

19 If the timing belt is to be re-used, mark its running direction with an arrow in chalk, and store it on its edge while it is off the engine.

20 Check the tensioner and sprockets as described in Section 9.

### Refitting and adjustment

21 Before refitting the belt, check that the crankshaft is still at the 90° BTDC position (dowel rod engaged) and that the timing marks on the two sprockets are still aligned.

22 Engage the timing belt with the teeth of the crankshaft sprocket, and then pull the belt vertically upright on its straight, right-hand run. Keep it taut, and engage it over the exhaust camshaft sprocket, then the inlet camshaft sprocket.

23 Check that none of the sprockets have moved, then feed the belt around the tensioner.

24 Refit the timing belt bottom cover.

25 Remove the dowel rod from the crankshaft.

26 Refit the crankshaft pulley and secure with the centre bolt and four additional bolts, tightened to the specified torque. Hold the crankshaft using the same procedure as for removal to tighten the centre bolt.

27 Slacken the timing belt tensioner retaining bolt slightly and allow the tensioner to automatically tension the belt.

28 Using a torque wrench applied to the inlet camshaft sprocket retaining bolt, apply a load of 40 Nm, in an anti-clockwise direction, to take up all the slack in the timing belt. Hold this load, and tighten the tensioner retaining bolt to the specified torque.

29 The remainder of refitting is a reversal of removal.

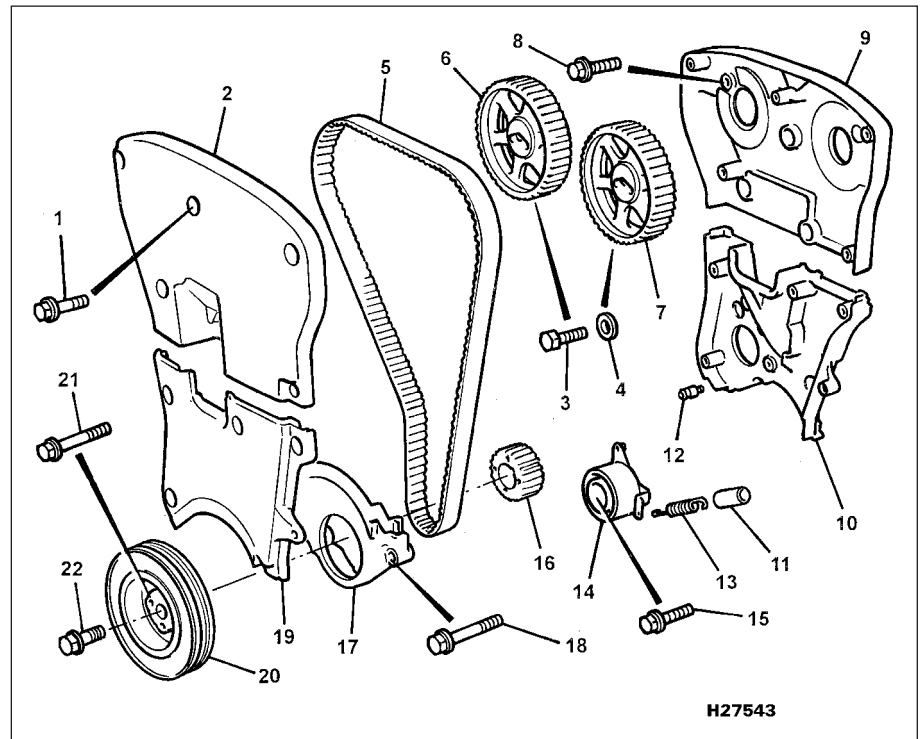

8.9 Timing belt components as fitted to "T" series engines

- |                             |                          |                             |
|-----------------------------|--------------------------|-----------------------------|
| 1 Upper cover bolt          | 9 Upper backplate        | 16 Crankshaft sprocket      |
| 2 Upper cover               | 10 Lower backplate       | 17 Bottom cover             |
| 3 Camshaft sprocket bolt    | 11 Spring sleeve         | 18 Bottom cover bolt        |
| 4 Washer                    | 12 Anchorage bolt        | 19 Centre cover             |
| 5 Timing belt               | 13 Tensioner spring      | 20 Crankshaft pulley        |
| 6 Inlet camshaft sprocket   | 14 Timing belt tensioner | 21 Pulley-to-sprocket bolts |
| 7 Exhaust camshaft sprocket | 15 Tensioner bolt        | 22 Pulley centre bolt       |
| 8 Backplate bolt            |                          |                             |

## 9 Timing belt tensioner and sprockets - removal, inspection and refitting



### Tensioner

#### Removal

- 1 Remove the timing belt as described in Sections 7, or 8, according to engine type.
- 2 On the "M" series engine, the tensioner will have been removed together with the timing belt; proceed to paragraph 6.
- 3 On the "T" series engine, slacken the tensioner retaining bolt and allow the tensioner to move fully under the action of the spring.
- 4 Unhook the tensioner spring from the anchorage stud.
- 5 Remove the tensioner retaining bolt, lift off the tensioner and remove the spring.

#### Inspection

- 6 Spin the tensioner, and ensure that there is no roughness or harshness in the bearing. Also check that the endfloat is not excessive and there is no sign of free play. Check the surface of the tensioner for any signs of roughness, nicks or scoring which may damage the timing belt. Renew the tensioner if worn.
- 7 On "T" series engines, measure the free length of the tensioner spring. If the free length is greater than that specified, renew the spring.

#### Refitting

- 8 Refitting is a reversal of removal.

### Camshaft sprockets

#### Removal

- 9 Remove the timing belt as described in Sections 7, or 8, according to engine type.
- 10 Undo the retaining bolt securing each sprocket to its respective camshaft. To prevent the sprockets turning as the bolts are undone, either insert a large screwdriver through one of the sprocket holes and engage it with one of the backplate bolts behind, or make up a holding tool from scrap metal,

which is of a scissor shape, with a bolts at each end to engage with the holes in the sprocket.

- 11 Withdraw the two sprockets from the camshafts, noting that they are not identical, and should be marked INLET (or IN) and EXHAUST on their front faces to avoid confusion. If no marks are visible, make your own to identify each sprocket (see illustration).

#### Inspection

- 12 Check the condition of the sprockets, inspecting carefully for any wear grooves, pitting or scoring around the teeth, or any wear ridges which might cause damage to the timing belt. Make sure that the dowels are not worn and are not a loose fit in the camshaft or sprocket holes.

#### Refitting

- 13 Refitting is a reversal of removal. Ensure that the sprockets are fitted to their correct camshafts and tighten the retaining bolt to the specified torque.

### Crankshaft sprocket

#### Removal

- 14 Remove the timing belt as described in Sections 7, or 8, according to engine type.
- 15 Slide the sprocket off the front of the crankshaft ("T" series engines).

#### Inspection

- 16 Check the condition of the sprocket, inspecting carefully for any wear grooves, pitting or scoring around the teeth, or any wear ridges which might cause damage to the timing belt. Examine the Woodruff key and its groove and make sure it is a tight fit.

#### Refitting

- 17 Refitting is a reversal of removal.

## 10 Camshaft oil seals - renewal



**Note:** The use of an oil seal extractor which screws into the seal inside circumference is

preferable for this operation. These are available at most accessory shops and can often be hired from tool hire outlets. In the absence of this type of tool, an alternative (but less satisfactory) method of removal is described in the following procedure.

### Front oil seals

- 1 Remove the camshaft sprockets as described in the previous Section.
- 2 On early "M" series engines undo the retaining bolt using an Allen key, and remove the timing belt idler pulley. Recover the spacer behind the pulley (see illustration).
- 3 Undo the bolts and remove the backplate from the cylinder head (see illustration).
- 4 The oil seals are now accessible for removal. Punch or drill two small holes opposite each other in the oil seal. Screw a self-tapping screw into each hole and pull on the screws with pliers to extract the seal.
- 5 Check that the housing is clean before fitting the new seal. Lubricate the lips of the seal and the running faces of the camshaft with clean engine oil, then carefully locate the seal over the camshaft and drive it squarely into position using a tube or a socket. Take great care not to turn over the lips of the seal as it is being fitted. An alternative method of fitting is to draw it squarely into position using the sprocket bolt and a distance piece.
- 6 With the seal fully inserted in its housing, refit the components removed for access then refit the camshaft sprockets as described in the previous Section.

### Rear oil seals

#### Exhaust camshaft oil seal

- 7 Refer to the relevant Part of Chapter 4 and remove the air cleaner assembly and intake trunking components as necessary for access.
- 8 Undo the two retaining bolts, withdraw the distributor cap, and place it to one side.
- 9 Undo the retaining Allen screw, and remove the distributor rotor arm.
- 10 Undo the two screws and remove the

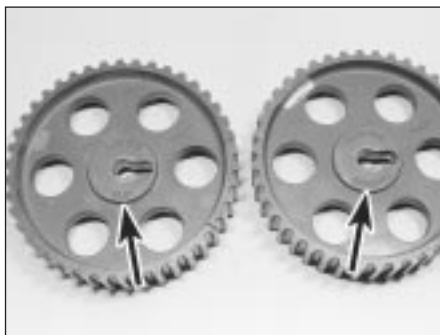

9.11 The camshaft sprockets are marked INLET (or IN) and EXHAUST on their front faces (arrowed)



10.2 Remove the timing belt idler pulley and recover the spacer (arrowed)



10.3 Undo the bolts (arrowed) and remove the backplate



10.10 Undo the two screws (arrowed) and remove the distributor adaptor plate

distributor adaptor plate from the cylinder head (see illustration).

11 Punch or drill two small holes opposite each other in the seal. Screw a self-tapping screw into each, and pull on the screws with pliers to extract the seal.

12 Clean the seal location in the cylinder head; polish off any burrs or raised edges, which may have caused the seal to fail in the first place.

13 Lubricate the lips of the new seal with clean engine oil and carefully locate the seal over the camshaft and into the cylinder head.

14 Using a tubular drift which bears on the hard outer edge of the seal, drive the seal fully into the head until it contact the inner land.

15 With the seal fully inserted in its housing, refit the components removed for access then refit the camshaft sprockets as described in the previous Section.

#### Inlet camshaft oil seal

16 Refer to the relevant Part of Chapter 4 and remove the air cleaner assembly and intake trunking components as necessary for access.

17 On cars with multi-point fuel injection, undo the throttle housing retaining nuts, withdraw the housing from the studs and move it aside. Undo the two bolts and remove the blanking plate or camshaft sensor (turbocharged engines) from the cylinder head (see illustration).

18 On cars fitted with a rear-mounted power steering pump, remove the auxiliary drivebelt



10.17 Undo the two bolts (arrowed) and remove the blanking plate

as described in Chapter 1, remove the camshaft pulley, then withdraw the spacer behind the pulley. Undo the two nuts and two bolts, and remove the power steering pulley backplate.

19 The seal can now be removed and refitted as described in paragraphs 11 to 15 above.

### 11 Camshafts and hydraulic tappets - removal, inspection and refitting

#### Removal

1 Remove the timing belt as described in the Sections 7 or 8, according to engine type.

2 Remove the camshaft sprockets as described in Section 9.

3 On early "M" series engines, undo the bolt securing the timing belt idler pulley to the cylinder head using an Allen key (see illustration). Withdraw the pulley, noting that there is a spacing washer fitted between the pulley and cylinder head backplate.

4 Undo the four bolts and remove the cylinder head backplate.

5 Undo the two retaining bolts, withdraw the distributor cap, and place it to one side.

6 Undo the retaining Allen screw, and remove the distributor rotor arm.

7 Undo the two screws and remove the distributor adaptor plate from the cylinder head.

8 On cars fitted with a rear-mounted power

steering pump driven off the inlet camshaft, remove the auxiliary drivebelt as described in Chapter 1, remove the camshaft pulley then withdraw the spacer behind the pulley. Undo the two nuts and two bolts, and remove the power steering pulley backplate.

9 On cars fitted with a front-mounted power steering pump, undo the two bolts and remove the blanking plate or camshaft sensor (turbocharged engines) from the cylinder head.

10 Remove the camshaft covers as described in Section 4.

11 Slacken the ten bolts securing each camshaft housing to the cylinder head, then remove all the bolts except two on each housing at diagonally opposite corners. Make sure that the heads of the bolts left in position are at least 5.0 mm (0.2 in) clear of the housing face. Note that two types of retaining bolts are used to secure the camshaft housings. The three bolts on the inner edge of each housing nearest to the spark plugs are plain bolts, while all the rest are patch bolts. Patch bolts are of the micro-encapsulated type, having their threads fitted with a locking/sealing compound. Obtain new plain and patch bolts prior to reassembly.

12 Using a plastic or hide mallet, carefully tap up each housing to release it from the locating dowels. When the housings are free, remove the remaining bolts and lift off the two housings (see illustration).

13 Carefully lift out the camshafts, and remove the oil seals at each end. Identify each camshaft, inlet or exhaust, with a label after removal.

14 Have a box ready with sixteen internal compartments, marked Inlet 1 to 8, and Exhaust 1 to 8, or mark a sheet of card in a similar way.

15 Lift out each tappet in turn, and place it upside down in its respective position in the box or on the card (see illustration). If the tappets are difficult to remove by hand, use the rubber sucker end of a valve grinding tool to lift them out.

16 Prior to reassembly, obtain new camshaft oil seals, a complete set of camshaft housing retaining bolts, and a tube of Loctite sealant 574.



11.3 Undo the timing belt idler pulley bolt

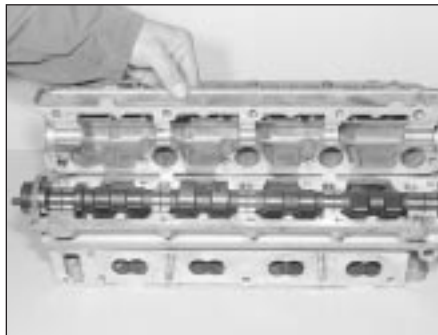

11.12 Removing the exhaust camshaft housing



11.15 Lift out the tappets and keep them in order



### Inspection

17 Clean and inspect the various components removed for signs of excessive wear.

18 Examine the camshaft bearing journals and lobes for damage or wear. If evident, a new camshaft must be fitted or one that has been renovated by a company specialising in exchange components.

19 The camshaft bearing bore diameters in the cylinder head should be measured and checked against the tolerances specified. A gauge will be required for this but if not available, check for excessive movement between the camshaft journals and the bearings. Alternatively, the Plastigage method, described in Part C of this Chapter, for main and big-end bearing running clearance checks, can be used. If the bearings are found to be unacceptably worn, either a new camshaft or a new cylinder head is required as the bearings are machined directly in the head.

20 It is seldom that the hydraulic tappets are badly worn in the cylinder head bores but again, if the tappets are scored, or the bores are found to be worn beyond an acceptable level, either the tappet(s) or the complete cylinder head must be renewed.

21 If the contact surface of the cam lobes show signs of depression or grooving, note that they cannot be renovated by grinding as the hardened surface will be removed and the overall length of the tappet(s) will be reduced. The self-adjustment point of the tappet will be exceeded as a result, so that the valve adjustment will be affected and they will then be noisy in operation. Therefore, renewal of the camshaft is the only remedy in this case.

### Refitting

22 Remove all traces of sealant from the camshaft housing retaining bolt holes in the



11.25 Fitting the camshaft oil seals

cylinder head, using an M8 x 1.25 mm tap. Alternatively, use one of the old bolts with two file grooves cut into its threads. Also ensure that there is no oil remaining at the bottom of the bolt holes.

23 Thoroughly lubricate the tappet bores in the cylinder head, and refit the tappets in their original positions.

24 Lubricate the camshaft journals and lobes, then place the camshafts in position. Temporarily place the sprockets over the ends of the camshafts, and position the camshafts in the cylinder head so that the sprocket timing marks are horizontal and towards each other.

25 Lubricate the sealing lips of the new oil seals, carefully ease them over the camshaft journals, and position them against the shoulder in the cylinder head (see illustration).

26 Apply a thin bead of Loctite sealant 574 to the camshaft housing-to-cylinder head mating face, then place both housings in position on the cylinder head (see illustration).

27 Fit new housing retaining bolts (3 plain bolts and 7 patch bolts for each housing) and tighten them in the order shown (see illustration). Note the locations of the two types of bolt.



11.26 Apply sealant to the camshaft housing mating face

28 The remainder of refitting is a reversal of removal. When the engine is finally started, be prepared for a considerable rattle from the tappets until they completely fill with oil. This may take a few minutes, and will be more pronounced if any of the tappets have been renewed.

## 12 Cylinder head - removal and refitting



**Warning:** Petrol is extremely flammable, so take extra precautions when disconnecting any part of the fuel system.

*Don't smoke, or allow naked flames or bare light bulbs in or near the work area. Don't work in a garage where a natural gas appliance (such as a clothes dryer or water heater) is installed. If you spill petrol on your skin, rinse it off immediately. Have a fire extinguisher rated for petrol fires handy, and know how to use it.*

### Single-point fuel injection engines

#### Removal

- 1 Drain the cooling system as described in Chapter 1.
- 2 Remove the air cleaner, air box and intake trunking as described in Chapter 4A.
- 3 Remove the timing belt as described in Section 7 or 8, according to engine type.
- 4 Remove the camshaft covers as described in Section 4.
- 5 Undo the nuts and separate the exhaust front pipe from the manifold flange. Recover the gasket.
- 6 Slacken the clips and disconnect the radiator top hose, and the expansion tank hose at the thermostat housing.
- 7 Disconnect the wiring multiplug at the coolant temperature sensor.
- 8 Undo the brake servo vacuum hose banjo union bolt on the right-hand side of the inlet manifold, and recover the two copper washers.
- 9 Slacken the clip and disconnect the heater hose at the inlet manifold, behind the brake servo vacuum hose.

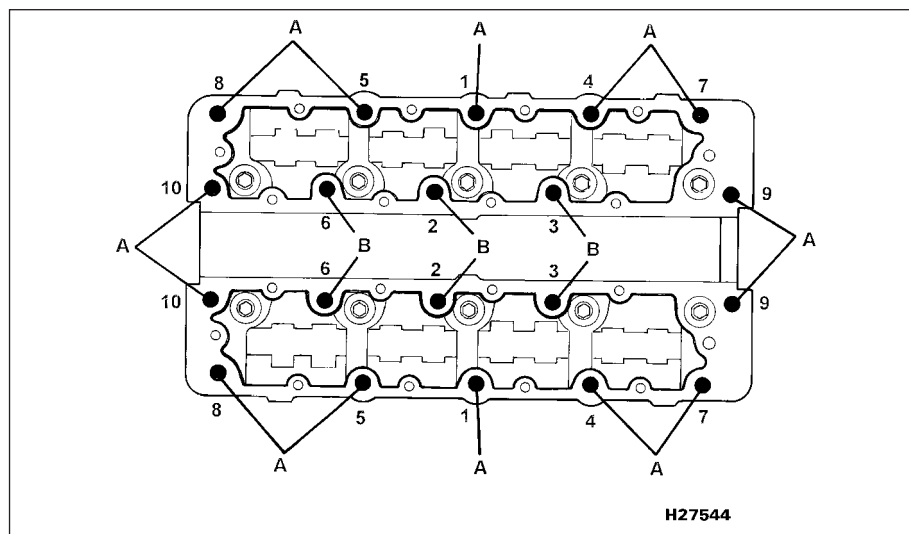

11.27 Camshaft housing retaining bolt identification and tightening sequence

A Patch bolt locations

B Plain bolt locations





12.13 Release the wiring harness clips from the bypass pipe

10 Undo the bolt securing the stay bar to the inlet manifold, below the heater hose.

11 Slacken the clips and disconnect the heater bypass hose at the thermostat housing.

12 Slacken the clip and disconnect the heater hose at the other end of the bypass pipe.

13 Undo the bolts securing the bypass pipe to the exhaust manifold, cylinder head and main coolant pipe, release the clips securing the wiring harness, and remove the bypass pipe from the engine (see illustration).

14 Slacken the clip and disconnect the coolant hose at the left-hand end of the inlet manifold.

15 Disconnect the vacuum hoses from the inlet manifold, adjacent to the coolant hose. Mark the location of each hose as it is disconnected.

16 Undo the bolt securing the support bracket to the inlet manifold, below the vacuum hoses.

17 At the rear of the engine below the inlet manifold, release the wire clip and detach the breather hose from the top of the oil separator. Also detach the hose from the crankcase ventilation system diverter valve (see illustration).

18 Disconnect the two wires to the inlet manifold heater temperature sensor, on the underside of the manifold, and the single lead to the manifold heater at the wiring connector.

19 Slacken the accelerator cable locknuts, and unscrew the lower locknut off the outer



12.17 Detach the hose from the diverter valve (arrowed)

cable end. Open the throttle at the throttle cam, slip the cable end out of the cam slot, and remove the cable from the support bracket. Release the cable from the camshaft cover support bracket, and place it clear of the engine.

20 On automatic transmission models, disconnect the kickdown cable, using the same procedure as for the accelerator cable.

21 Disconnect the wiring multiplugs at the idle speed stepper motor, the fuel injector, and the throttle potentiometer. Move the wiring harness clear of the cylinder head.

22 Place absorbent rags around the fuel filter outlet union banjo bolt on the left-hand side of the filter, then slowly unscrew the bolt to release the fuel system pressure. Remove the bolt and recover the two copper washers after the pressure has been released. Tape over the filter orifice and banjo union to prevent fuel loss and dirt ingress.

23 Disconnect the fuel return hose at the pipe below the fuel filter.

24 Remove the dipstick from the dipstick tube.

25 On cars fitted with a rear-mounted power steering pump, extract the circlip from the end of the power steering pump drivebelt tension adjuster bolt. Slide the adjuster rearwards, and undo all the accessible bolts securing the adjuster bracket to the cylinder head. Now move the adjuster the other way, and undo the remaining bolts, then remove the adjuster assembly complete.

26 Progressively slacken all the cylinder head

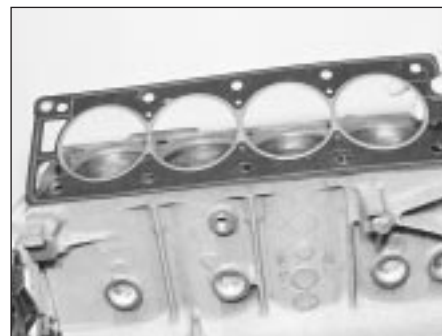

12.30 Locate a new cylinder head gasket over the dowels

retaining bolts, in the reverse sequence to that shown (see illustration 12.32c). Remove the bolts when all have been slackened.

27 With the help of an assistant, lift the cylinder head, complete with manifolds, off the engine. If the head is stuck, it can be carefully levered up using a large screwdriver between the cylinder block and the protruding cylinder head flanges. Do not insert the screwdriver under the head-to-block mating face. Place the head on blocks on the bench to protect the valves.

28 Remove the cylinder head gasket from the block.

29 Prior to refitting, ensure that the cylinder block and head mating faces are thoroughly clean and dry, with all traces of old gasket removed. Clean the threads of the retaining bolts, and remove any oil, water and thread sealer from the bolt holes.

### Refitting

30 Locate a new gasket over the dowels on the cylinder block (see illustration).

31 Check that the crankshaft is still positioned at the 90° BTDC position, and that the timing marks on the camshaft sprockets are aligned.

32 Lower the cylinder head assembly onto the gasket, and refit the retaining bolts. Working in the sequence shown, tighten the retaining bolts in stages, to the specified torque and angle settings given in the Specifications (see illustrations).

33 The remainder of refitting is a reversal of

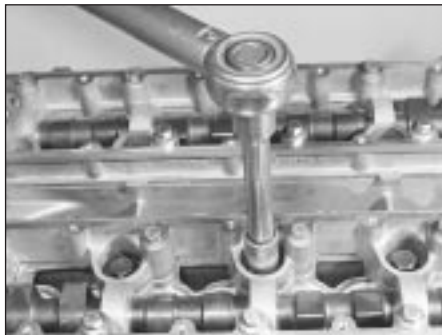

12.32a Tighten the cylinder head bolts to the specified torque . . .



12.32b . . . then angle-tighten the bolts to the specified angular setting

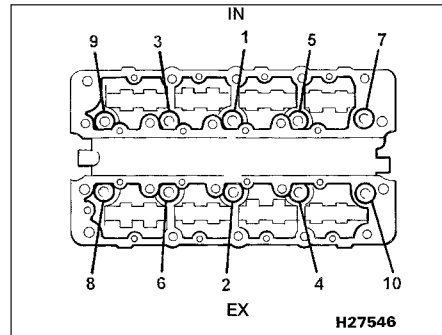

12.32c Cylinder head bolt tightening sequence

removal but refer to the relevant Sections and Chapters for adjustment details as necessary.

### Multi-point fuel injection engines

#### Removal

**34** Carry out the operations described in Paragraphs 1 to 8.

**35** On turbocharged engines remove the exhaust manifold as described in the relevant part of Chapter 4.

**36** Slacken the clip and disconnect the heater hose at the other end of the bypass pipe.

**37** Undo the bolts securing the bypass pipe to the exhaust manifold, cylinder head and main coolant pipe, and remove the bypass pipe.

**38** Slacken the clips and disconnect the two coolant hoses from the underside of the throttle housing.

**39** At the rear of the engine, disconnect the wiring multiplugs and leads at the crankshaft sensor, knock sensor, oil pressure switch and oil pressure transducer.

**40** Disconnect the main engine wiring loom multiplug(s) on the right-hand side valance as necessary, to enable part of the loom to be removed with the cylinder head.

**41** Check that all the wiring likely to impede removal of the cylinder head and its ancillaries has been disconnected, and the harness moved clear. It may be necessary to disconnect additional wiring, depending on options or additional equipment fitted.

**42** Disconnect the breather hoses from the oil separator.

**43** Open the throttle fully by hand, and slip the accelerator inner cable end out of the slot on the throttle lever.

**44** Slacken the outer cable locknuts, and unscrew the outer locknut, nearest to the cable end, fully. Remove the washer and rubber bush, then withdraw the cable from the support bracket.

**45** On automatic transmission models, disconnect the kickdown cable, using the same procedure as for the accelerator cable.

**46** Place absorbent rags around the fuel filter outlet union banjo bolt on the left-hand side of the filter, then slowly unscrew the bleed screw in the centre of the bolt to release the fuel system pressure. Tighten the bleed screw when the pressure has been released. Undo the outlet union banjo bolt, and recover the two copper washers. Tape over the filter orifice, and banjo union to prevent fuel loss and dirt entry.

**47** Unscrew the union nut and disconnect the fuel return hose at the fuel pressure regulator, on the left-hand side of the inlet manifold.

**48** Remove the dipstick from the dipstick tube.

**49** On cars fitted with a rear-mounted power steering pump, extract the circlip from the end of the power steering pump drivebelt tension

adjuster bolt. Slide the adjuster rearwards, and undo all the accessible bolts securing the adjuster bracket to the cylinder head. Now move the adjuster the other way, and undo the remaining bolts, then remove the adjuster assembly complete.

**50** Progressively slacken all the cylinder head retaining bolts, in the reverse sequence to that shown (see illustration 12.32c). Remove the bolts when all have been slackened.

**51** With the help of an assistant, lift the cylinder head, complete with manifolds, off the engine. If the head is stuck, it can be carefully levered up using a large screwdriver between the cylinder block and the protruding cylinder head flanges. Do not insert the screwdriver under the head-to-block mating face. Place the head on blocks on the bench to protect the valves.

**52** Remove the cylinder head gasket from the block.

**53** Prior to refitting, ensure that the cylinder block and head mating faces are thoroughly clean and dry, with all traces of old gasket removed. Clean the threads of the retaining bolts, and remove any oil, water and thread sealer from the bolt holes.

#### Refitting

**54** Locate a new gasket over the dowels on the cylinder block.

**55** Check that the crankshaft is still positioned at the 90° BTDC position, and that the timing marks on the camshaft sprockets are aligned.

**56** Lower the cylinder head assembly onto the gasket, and refit the retaining bolts. Working in the sequence shown, tighten the retaining bolts in stages, to the specified torque and angle settings given in the Specifications (see illustration 12.32c).

**57** The remainder of refitting is a reversal of removal but refer to the relevant Sections and Chapters for adjustment details as necessary.

### 13 Sump - removal and refitting



#### Removal

**1** Disconnect the battery negative (earth) lead (refer to Chapter 5, Section 1).

**2** Apply the handbrake, jack up the front of the car and support it on axle stands.

**3** Drain the engine oil as described in Chapter 1.

**4** Remove the exhaust front section with reference to the appropriate Part of Chapter 4.

**5** Undo the bolts securing the longitudinal support member to the underbody beneath the engine, and remove the member.

**6** Disconnect the crankcase breather



13.8 Sump special retaining bolt location

hose from the pipe stub on the side of the sump.

**7** Where applicable, release the turbocharger oil return hose from the sump.

**8** Slacken, then remove, the sump retaining bolts, noting that the corner bolt on the drain plug side at the flywheel end is longer than the rest, and has a flat washer and elongated washer in addition to the normal spring washer (see illustration).

**9** Withdraw the sump from the crankcase, tapping it from side to side with a hide or plastic mallet if it is stuck. Recover the sump gasket.

**10** If the oil pick-up tube and strainer are to be removed, undo the two bolts securing the tube flange to the crankcase, and the single bolt securing the support bracket to the main bearing cap (see illustration).

**11** Slide the support bracket from under the crankcase breather oil return pipe, and remove the pick-up pipe and tube from the crankcase. Recover the O-ring from the pick-up pipe flange.

**12** Clean the sump thoroughly, and remove all traces of old gasket and sealant from the mating faces of the sump and crankcase.

**13** If removed, clean the pick-up pipe, and the filter gauze in the strainer.

#### Refitting

**14** Place a new O-ring seal on the pick-up pipe flange, fit the pipe and strainer assembly, and secure with the retaining bolts,



13.10 Undo the two pick-up pipe-to-crankcase bolts



13.14 Fit a new O-ring to the pick-up pipe flange



13.15 Apply sealant to the main bearing cap joints

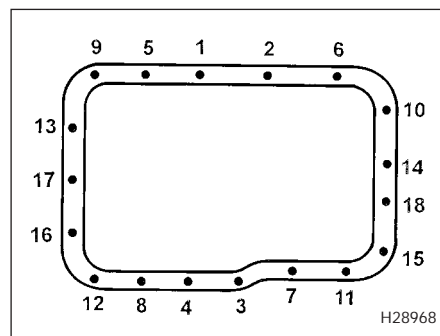

13.16 Sump retaining bolt tightening sequence

tightened to the specified torque (see illustration).

15 Apply a bead of RTV sealant to the joint between Nos 1 and 5 main bearing caps and the edge of the crankcase (see illustration). Apply gasket sealant to the sump and crankcase mating faces, then place a new gasket in position.

16 Refit the sump, and tighten the retaining bolts progressively, and in sequence, to the specified torque (see illustration).

17 Refit the crankcase breather hose and turbocharger oil return hose.

18 Refit the exhaust front section as described in Chapter 4.

19 Refit the longitudinal support member.

20 Lower the car to the ground, reconnect the battery and fill the engine with oil as described in Chapter 1.

a socket and long handle, slacken the crankshaft pulley centre retaining bolt. Lock the flywheel ring gear, through the starter motor aperture, using a large screwdriver or similar tool to prevent the crankshaft rotating as the pulley bolt is undone. Remove the bolt and withdraw the pulley.

4 On later "M" series engines and all "T" series engines, withdraw the sprocket from the crankshaft.

5 Remove the Woodruff key from the slot in the crankshaft.

6 Unscrew the oil pipe unions on the side of the filter housing, then undo the bolt securing the oil pipe retaining clip and timing belt backplate to the crankcase (see illustration).

Where fitted unscrew the oil cooler feed and return pipe unions from the pump housing.

7 Undo the retaining bolts and remove the timing belt lower backplate.

8 Undo the housing retaining bolts, and withdraw the assembly from the crankshaft and crankcase (see illustration). Recover the gasket.

### Refitting

9 Ensure that the pump housing and crankcase mating faces are thoroughly clean, with all traces of old gasket and sealer removed.

10 Apply a bead of RTV sealant to the vertical joint between the main bearing cap and the crankcase, and smear jointing compound to both faces of a new gasket. Place the gasket in position on the crankcase.

11 Lubricate the lip of the oil seal, then locate the pump housing in place.

12 Fit the retaining bolts, and tighten them to the specified torque.

13 Refit the timing belt lower backplate.

14 Reconnect the oil pipe and where applicable, the oil cooler unions, and refit the pipe support clip retaining bolt.

15 Place the Woodruff key in its crankshaft groove, then refit the crankshaft pulley, retaining bolt and washer.

16 Refit the crankshaft sprocket on later "M" series engines and all "T" series engines.

17 On early "M" series engines, refit the crankshaft pulley and tighten the retaining bolt to the specified torque. Prevent the crankshaft rotating using the same method as used for removal when tightening the bolt. Refit the starter motor as described in Chapter 5.

18 Refit the timing belt as described in Section 7 or 8 as applicable.

19 Fit a new oil filter, and fill the engine with oil as described in Chapter 1.

## 14 Oil pump - removal and refitting



### Removal

1 Remove the timing belt as described in Section 7 or 8 according to engine type. On "T" series engines also remove the timing belt tensioner as described in Section 9.

2 Drain the engine oil and remove the oil filter as described in Chapter 1.

3 On early "M" series engines, remove the starter motor as described in Chapter 5. Using



14.6 Undo the bolt securing the oil pipe retaining clip and timing belt backplate



14.8 Oil pump housing retaining bolts (arrowed)

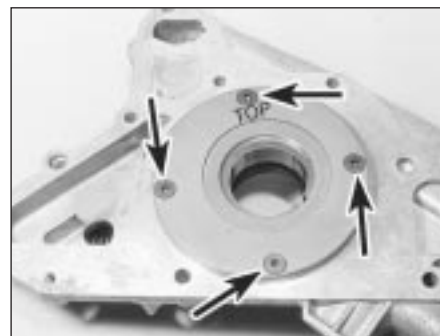

15.1 Oil pump cover retaining bolts (arrowed)

## 15 Oil pump - dismantling, inspection and reassembly



### Dismantling

1 With the pump housing removed from the engine, undo the four Torx retaining bolts on the housing rear face, and lift off the pump cover (see illustration).





15.2 Oil pressure relief valve components

2 To remove the pressure relief valve components, extract the split pin and withdraw the plug cap, spring and relief valve plunger (see illustration).

3 Using a screwdriver, prise out the crankshaft front oil seal from the oil pump housing.

### Inspection

4 Inspect the condition of the inner and outer rotors for visual signs of scoring or wear ridges. Note that the pump internal parts are not available separately, and if there is any sign of wear, a complete new oil pump and housing assembly must be obtained.

5 Check the plunger for scoring or wear ridges, and renew if necessary. Also renew the plug cap O-ring if it shows signs of deterioration.

### Reassembly

6 Liberally lubricate the pump rotors to prime the pump, then refit the pump cover and secure with the four Torx bolts.

7 Lubricate the relief valve components with engine oil, then refit the plunger, spring and plug cap. Secure the cap with a new split pin.

8 Place a new oil seal in position, and carefully tap it home with the aid of a mallet, block of wood and the old oil seal.

## 16 Crankshaft oil seals - renewal



### Front oil seal

1 Remove the timing belt as described in Section 7 or 8, according to engine type.

2 On early "M" series engines, remove the starter motor as described in Chapter 5. Using a socket and long handle, slacken the crankshaft pulley centre retaining bolt. Lock the flywheel ring gear, through the starter motor aperture, using a large screwdriver or similar tool to prevent the crankshaft rotating as the pulley bolt is undone. Remove the bolt and withdraw the pulley.

3 On later "M" series engines and all "T" series engines, withdraw the sprocket from the crankshaft.

4 Remove the Woodruff key from the slot in the crankshaft.

5 Punch or drill two small holes opposite each other in the seal. Screw a self-tapping screw into each, and pull on the screws with pliers to extract the seal.

6 Clean the seal housing, and polish off any burrs or raised edges, which may have caused the seal to fail in the first place.

7 Lubricate the lips of the new seal with clean engine oil and carefully locate the seal over the crankshaft and into the housing.

8 Using a tubular drift which bears on the hard outer edge of the seal, drive the seal into the housing until it is flush with the housing face.

9 Refit the Woodruff key to the crankshaft.

10 On later "M" series engines and all "T" series engines, refit the sprocket to the crankshaft.

11 On early "M" series engines, refit the crankshaft pulley and tighten the retaining bolt to the specified torque. Prevent the crankshaft rotating using the same method as used for removal when tightening the bolt. Refit the starter motor as described in Chapter 5.

12 Refit the timing belt as described in Section 7 or 8 as applicable.

### Rear oil seal

13 Remove the flywheel/driveplate as described in Section 17.

#### "M" series engines

14 Punch or drill two small holes opposite each other in the seal. Screw a self-tapping screw into each, and pull on the screws with pliers to extract the seal.

15 Clean the seal housing, and polish off any burrs or raised edges, which may have caused the seal to fail in the first place.

16 Lubricate the lips of the new seal with clean engine oil and carefully locate the seal on the end of the crankshaft.

17 Using a tubular drift which bears on the hard outer edge of the seal, drive the seal into the housing until it is flush with the housing face.

18 Clean off any surplus oil then refit the flywheel/driveplate as described in Section 17.

#### "T" series engines

19 Drain the engine oil as described in Chapter 1.

20 Slacken all the sump securing bolts in a progressive sequence, but do not slacken the three at the timing belt end.

21 Completely remove the two bolts at the other end, securing the sump to the oil seal carrier.

22 Undo the five bolts and carefully remove the oil seal carrier from the cylinder block dowels and crankshaft. Take great care not to damage the sump gasket as the carrier is removed.

23 Note that the oil seal carrier and the oil seal itself, are supplied as an assembly; the seal is not available separately.

24 Before refitting, inspect the sump gasket; if it was damaged in any way during removal it must be renewed.

25 Clean the end of the crankshaft, and polish off any burrs or raised edges, which may have caused the seal to fail in the first place.

26 Lubricate the lips of the new seal with clean engine oil and carefully locate the seal on the end of the crankshaft.

27 Push the oil seal carrier into position over the locating dowels and refit the retaining bolts. Progressively tighten the carrier bolts to the specified torque, starting with the two at the bottom, then the two in the centre, and finally the one at the top.

28 Tighten the sump bolts to the specified torque, in the correct sequence (see Section 13).

29 Refit the flywheel/driveplate as described in Section 17. Refill the engine with oil on completion of refitting, and check for leaks around the sump flange when the engine is run.

## 17 Flywheel/driveplate - removal, inspection and refitting



### Removal

1 With the engine removed from the car and separated from the transmission, or with the transmission removed as described in Chapter 7, remove the clutch assembly (manual transmission) as described in Chapter 6.

2 Where fitted, knock back the tabs of the locking plate, using a screwdriver or small chisel, and undo the six flywheel/driveplate retaining bolts. **Note that the retaining bolts are of the encapsulated type, incorporating a locking compound in their threads, and new bolts must be obtained for reassembly.**



To prevent the flywheel turning, lock the ring gear teeth using a small strip of angle iron engaged in the teeth and against the adaptor plate dowel.

3 Lift off the locking plate, then withdraw the flywheel/driveplate from the crankshaft. On automatic transmission models, recover the spacer from the end of the crankshaft.

### Inspection

4 Inspect the starter ring gear on the flywheel or driveplate for wear or broken teeth. If evident, the ring gear should be renewed. On automatic transmission models, the ring gear is bolted to the driveplate, and renewal is straightforward. On manual transmission models however, the ring gear is a shrink fit on the flywheel, and renewal entails drilling



the old ring then splitting it with a chisel. The new ring must then be heated so that it expands slightly, and allowed to cool when in position on the flywheel. As it cools, it contracts to a smaller diameter than the flywheel so as to provide a tight interference fit. The temperatures involved in this operation are critical to avoid damaging the ring gear, and the work should be carried out by a Rover dealer or motor engineering works.

5 The clutch friction surface on the flywheel should be checked for grooving or cracks, the latter being caused by overheating. If these conditions are evident, renewal of the flywheel is necessary.

6 On manual and automatic transmission models, check the condition of the reluctor ring teeth. If any are bent, broken, or in any way damaged, renew the ring, which is bolted to the flywheel or driveplate.

### Refitting

7 Refitting is a reversal of removal. Tighten the new bolts to the specified torque, then bend over the tabs of a new locking plate.

## 18 Engine/transmission mountings - inspection and renewal



### Inspection

1 The engine/transmission mountings seldom require attention, but broken or deteriorated mountings should be renewed immediately, or the added strain placed on the driveline components may cause damage or wear (see illustration).

2 During the check, the engine/transmission unit must be raised slightly, to remove its weight from the mountings.

3 Raise the front of the vehicle, and support it securely on axle stands. Position a jack under the sump, with a large block of wood between the jack head and the sump, then carefully raise the engine/transmission just enough to take the weight off the mountings.

4 Check the mountings to see if the rubber is cracked, hardened or separated from the metal components. Sometimes the rubber will split right down the centre.

5 Check for relative movement between each mounting's brackets and the engine/transmission or body (use a large screwdriver or lever to attempt to move the mountings). If movement is noted, lower the engine and check-tighten the mounting fasteners.

### Renewal

#### Front mounting

6 Remove the battery as described in Chapter 5, then undo the retaining bolts and remove the battery tray.

7 Remove the air cleaner assembly as described in the relevant part of Chapter 4.

8 Undo the nut securing the mounting to the engine mounting bracket, and the two bolts securing the mounting to the front chassis member.

9 Using a jack and interposed block of wood, raise the engine slightly until the mounting stud can be withdrawn from the bracket, then remove the mounting from the car.

10 Renew the mounting if it shows any sign of damage, contamination or separation of the rubber-to-metal bond.

11 Refitting is a reversal of removal, but ensure that the small peg on the mounting top face engages with the hole in the bracket, and tighten the bolts and nut to the specified torque (Chapter 2, Part C).

#### Rear mounting

12 Remove the air cleaner assembly and air intake trunking as described in the relevant part of Chapter 4.

13 Jack up the front of the car and support it on axle stands.

14 Undo the bolts and remove the longitudinal support member from beneath the engine.

15 Support the engine and transmission

assembly on a jack with interposed block of wood.

16 Undo and remove all the nuts and bolts securing the mounting to its mounting bracket and chassis member, and the mounting bracket to the engine.

17 Withdraw the mounting bracket from below, followed by the mounting. If there is a spacer located between the mounting and mounting bracket, retain this for refitting with the existing mounting, but discard it if the mounting is being renewed.

18 Renew the mounting if it shows any sign of damage, contamination or separation of the rubber-to-metal bond.

19 Refitting is a reversal of removal, but ensure that the small peg on the mounting top face engages with the hole in the bracket, and tighten the bolts and nut to the specified torque (Chapter 2, Part C).

#### Right-hand mounting

20 Position a jack and interposed block of wood under the sump, and just take the weight of the engine.

21 Undo the bolts securing the power steering pipe support brackets, and move the

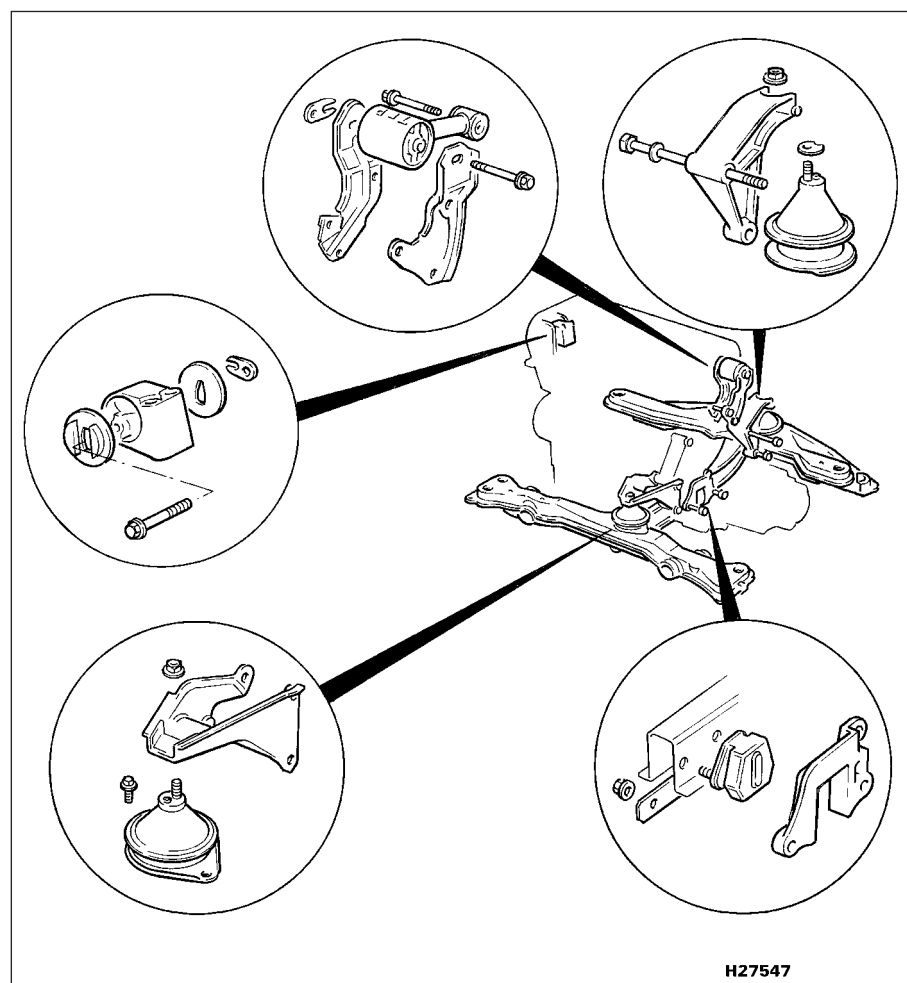

18.1 Engine mounting components (manual transmission shown - automatic transmission similar)

pipes slightly to gain access to the right-hand mounting.

**22** Undo the mounting through-bolt, and recover the special nut. Note that the forked end of the nut plate locates over a stud on the body bracket.

**23** Undo the two bolts and remove the mounting and snubber plates from the bracket on the engine.

**24** Renew the mounting if it shows any sign of damage, contamination or separation of the rubber-to-metal bond.

**25** Refitting is a reversal of removal, but tighten the bolts to the specified torque (Chapter 2, Part C). Ensure that the mounting is correctly orientated when fitting, with its central casting web facing upwards.

### Rear tie-bar

**26** On cars equipped with single-point fuel injection, remove the air cleaner assembly as described in Chapter 4A.

**27** Drain the cooling system as described in Chapter 1, then disconnect the heater hoses and coolant hoses in the vicinity of the tie-bar as necessary to provide access.

**28** Undo the two through-bolts securing the tie-bar to its mounting brackets. Note that at the larger end of the tie-bar, the through-bolt

is retained by a forked nut which engages over a peg on the engine bracket.

**29** Using a screwdriver if necessary, prise the tie-bar from its brackets and remove it from the car.

**30** Renew the tie-bar if it shows any sign of damage, contamination or separation from the rubber-to-metal bond.

**31** Refitting is a reversal of removal, but ensure that the tie-bar is positioned with the word TOP, on the larger end of the bar, uppermost. Tighten the through-bolts to the specified torque (Chapter 2, Part C), then refit the air cleaner as described in Chapter 4A. Refill the cooling system as described in Chapter 1 on completion.

### Snubber

**32** Jack up the front of the car and support it on axle stands.

**33** Undo the retaining bolts and remove the longitudinal support member from under the engine.

**34** Undo the nuts and remove the backing plate and snubber from the longitudinal support member.

**35** If required, undo the nuts and bolts and remove the snubber bracket from the transmission adaptor plate.

**36** Renew the snubber if it shows any sign of

damage, contamination or separation of the rubber-to-metal bond. Check also for signs of wear on the snubber bracket, and renew if necessary.

**37** Refitting is a reversal of removal. Centralise the snubber in its bracket before tightening the bolts and nuts to the specified torque (Chapter 2, Part C).

### Lower tie-bar

**38** Jack up the front of the car and support it on axle stands.

**39** Undo the two through-bolts securing the tie-bar to its mounting brackets. Note that at the larger end of the tie-bar, the through-bolt is retained by a forked nut which engages over a peg on the mounting bracket.

**40** Using a screwdriver if necessary, prise the tie-bar from its brackets and remove it from the car.

**41** Renew the tie-bar if it shows any signs of damage, contamination or separation of the rubber-to-metal bond.





**42** Refitting is the reverse sequence to removal, but ensure that the tie-bar is positioned with the letters BTM, on the larger end of the bar, facing downwards, and tighten the through-bolts to the specified torque (Chapter 2, Part C).

# Chapter 2 Part B: V6 engine – in-car engine repair procedures

## Contents

Auxiliary drivebelts check and renewal . . . . .	See Chapter 1	Exhaust manifold - removal and refitting . . . . .	9
Camshaft and hydraulic tappets - removal, inspection and refitting . . . . .	15	Exhaust valve rocker clearances - adjustment . . . . .	7
Camshaft covers - removal and refitting . . . . .	5	Flywheel/driveplate - removal, inspection and refitting . . . . .	22
Camshaft oil seals - renewal . . . . .	14	General information . . . . .	1
Compression test - description and interpretation . . . . .	3	Inlet manifold - removal and refitting . . . . .	8
Crankshaft oil seals - renewal . . . . .	20	Oil cooler and filter head - removal and refitting . . . . .	18
Crankshaft pulley - removal and refitting . . . . .	10	Oil pump - removal and refitting . . . . .	19
Cylinder head - removal and refitting . . . . .	16	Repair operations possible with the engine in the vehicle . . . . .	2
Cylinder head, rocker gear and valve assemblies - cleaning and inspection . . . . .	See Chapter 2C	Spark plug renewal . . . . .	See Chapter 1
Cylinder head side covers - removal and refitting . . . . .	6	Sump - removal and refitting . . . . .	17
Engine oil and filter change . . . . .	See Chapter 1	Timing belt - removal, refitting and adjustment . . . . .	12
Engine oil level check . . . . .	See Chapter 1	Timing belt covers - removal and refitting . . . . .	11
Engine overhaul - general information . . . . .	See Chapter 2C	Timing belt tensioner and sprockets - removal, inspection and refitting . . . . .	13
Engine/transmission - removal and refitting . . . . .	See Chapter 2C	Top Dead Centre (TDC) for number 1 piston - locating . . . . .	4
Engine/transmission mountings - inspection and renewal . . . . .	21	Water pump - removal and refitting . . . . .	See Chapter 3

## Degrees of difficulty

<b>Easy</b> , suitable for novice with little experience 	<b>Fairly easy</b> , suitable for beginner with some experience 	<b>Fairly difficult</b> , suitable for competent DIY mechanic 	<b>Difficult</b> , suitable for experienced DIY mechanic 	<b>Very difficult</b> , suitable for expert DIY or professional 
--	---	---	--	---

2B

## Specifications

### General

Engine type . . . . .	V6, single overhead camshaft per bank
Engine code:	
2.5 litre engines . . . . .	C25A
2.7 litre engines . . . . .	C27A
Capacity:	
2.5 litre engines . . . . .	2496 cc
2.7 litre engines . . . . .	2675 cc
Bore:	
2.5 litre engines . . . . .	84 mm
2.7 litre engines . . . . .	87.0 mm
Stroke (all engines) . . . . .	75.0 mm
Compression ratio:	
2.5 litre engines . . . . .	9.6:1
2.7 litre engines:	
Non-catalyst equipped engines . . . . .	9.4:1
Catalyst equipped engines . . . . .	9.0:1
Firing order . . . . .	1-4-2-5-3-6 (No 1 cylinder at timing belt end on rear bank)
Direction of crankshaft rotation . . . . .	Clockwise (seen from right-hand side of vehicle)
Radial clearance on rocker shaft . . . . .	0.08 mm maximum

### Cylinder head

Maximum gasket face distortion . . . . .	0.2 mm
--	--------

### Camshafts and hydraulic tappets

Camshaft endfloat . . . . .	0.05 to 0.15 mm
Camshaft bearing running clearance:	
New . . . . .	0.045 to 0.081 mm
Used . . . . .	0.10 mm maximum
Hydraulic tappet seating stroke . . . . .	0.08 mm maximum

**Lubrication**

Engine oil type/specification . . . . .	See Chapter 1
Engine oil capacity . . . . .	See Chapter 1

**Torque wrench settings**

	Nm	lbf ft
Cylinder head bolts . . . . .	68	50
Cylinder head side cover bolts . . . . .	12	9
Timing belt cover bolts . . . . .	12	9
Timing belt backplate bolts . . . . .	12	9
Timing belt tensioner bolt . . . . .	43	32
Camshaft sprocket bolts . . . . .	32	24
Camshaft carrier bolts:		
4 bolts at . . . . .	12	9
2 bolts at . . . . .	28	21
Oil gallery bolts:		
8 bolts at . . . . .	28	21
2 bolts at . . . . .	12	9
Crankshaft pulley centre bolt . . . . .	115	85
Driveplate bolts . . . . .	75	55
Flywheel bolts . . . . .	105	78
Filter head bolts . . . . .	22	16
Main bearing caps:		
Bolts 1 to 8 . . . . .	41	30
Bolts 9 to 16 . . . . .	68	50
Bolts 17 to 24 . . . . .	50	37
Big-end bearing caps . . . . .	50	37
Oil cooler centre bolt . . . . .	50	37
Oil pump housing bolts:		
M6 bolts . . . . .	12	9
M8 bolts . . . . .	22	16
Oil pick-up pipe bolts . . . . .	12	9
Sump nuts and bolts . . . . .	12	9
Rocker arm guide plate bolts . . . . .	12	9
Inlet manifold retaining nuts and bolts . . . . .	22	16
Exhaust manifold retaining nuts . . . . .	45	33
Exhaust manifold heat shield bolts . . . . .	12	9
Front engine mounting to transmission bracket . . . . .	80	59
Front engine mounting bracket to transmission . . . . .	40	30
Rear engine mounting bracket to transmission . . . . .	40	30
Right-hand engine mounting through-bolt . . . . .	45	33
Right-hand engine mounting to engine bracket . . . . .	60	44
Right-hand engine mounting bracket to engine . . . . .	25	18
Engine rear tie-bar to mounting bracket . . . . .	75	55
Engine rear tie-bar mounting bracket bolts:		
M10 bolts . . . . .	45	33
M12 bolts . . . . .	85	63
Engine rear tie-bar through-bolt . . . . .	85	63
Longitudinal support member to underbody . . . . .	45	33
Engine snubber bracket to transmission . . . . .	45	33

**1 General information****How to use this Chapter**

1 This Part of Chapter 2 is devoted to repair procedures possible while the engine is still installed in the car, and includes only the Specifications relevant to those procedures. Since these procedures are based on the assumption that the engine is installed in the car, if the engine has been removed and mounted on a stand, some of the preliminary dismantling steps outlined will not apply.

2 Information concerning engine / trans-

mission removal and refitting, and engine overhaul, can be found in Part C of this Chapter, which also includes the Specifications relevant to those procedures.

**Engine description**

3 The V6 engine fitted to Rover 825, 827 and Sterling models is a water-cooled, six-cylinder, four-stroke petrol engine, of single overhead camshaft configuration per bank, and 2494 cc (2.5 litre) or 2675 cc (2.7 litre) capacity. The larger capacity being achieved by an increase in cylinder bore diameter. The 2.5 litre engine was fitted to Rover 825 models from 1986 until 1988, to be replaced by the 2.7 litre engine which is currently still in production.

4 The combined crankcase and cylinder block is of die-cast aluminium alloy construction, and houses the pistons, connecting rods and crankshaft. The solid skirt cast aluminium alloy pistons have two compression rings and an oil control ring, and are retained on the connecting rods by semi-floating gudgeon pins which are an interference fit in the connecting rods. The forged steel connecting rods are attached to the crankshaft by renewable shell type big-end bearings. The crankshaft is carried in four main bearings, also of the renewable shell type. Crankshaft endfloat is controlled by thrust washers which are located on either side of No 3 main bearing.

5 A single overhead camshaft is located in



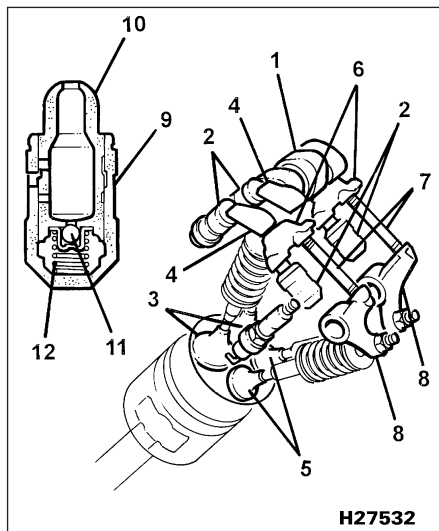

1.6 General arrangement of the V6 engine valve gear

- |                          |                  |
|--------------------------|------------------|
| 1 Camshaft               | 7 Pushrods       |
| 2 Hydraulic tappet       | 8 Rocker arms    |
| 3 Inlet valves           | 9 Tappet body    |
| 4 Inlet valve slippers   | 10 Plunger       |
| 5 Exhaust valves         | 11 Check ball    |
| 6 Exhaust valve slippers | 12 Return spring |

each cylinder head, and is retained in position by a housing bolted to the cylinder head upper face. The camshafts are supported by bearing journals machined directly into the head and housings. Drive to the camshafts is by an internally-toothed composite rubber timing belt, from a sprocket on the front end of the crankshaft. The belt also drives the water pump pulley, and an automatic tensioner is fitted to eliminate backlash and prevent slackness of the belt.

6 The camshafts operate slippers which pivot on hydraulic tappets, one for each valve. The inlet valves are operated directly from the camshaft slippers, whereas the exhaust valves are operated indirectly from the camshaft slippers by pushrods and adjustable rocker arms (see illustration).

7 The engine utilizes four valves per cylinder, mounted at an inclined angle, and running in guides which are pressed into the cylinder head. The valves are of small diameter, to improve breathing efficiency and reduce valve mass.

8 The distributor is attached to the rear of the front facing cylinder head and is driven off the rear of the camshaft. The power steering pump and alternator are mounted on top of the engine and driven by separate drivebelts from the crankshaft pulley.

9 Blow-by gases from the crankcase are vented by a positive crankcase ventilation system back into the intake air stream for combustion.

10 The pressed-steel sump is attached to the underside of the crankcase, and acts as a reservoir for the engine oil. The oil pump

draws oil through a strainer attached to the pick-up pipe and submerged in the oil. The pump passes the oil along a passage and into the full-flow filter and oil cooler assembly, mounted on the front of the engine. The filtered oil flows from the filter and enters the main cylinder block oil gallery, which feeds the crankshaft main bearings. Oil passes from the main bearings, through drillings in the crankshaft to the big-end bearings.

11 A drilling from the main oil gallery feeds the cylinder head gallery, where the oil is directed to the camshaft bearings, cams and cam slippers, and to the hydraulic tappets, rocker arm pivots and rocker arm shafts. The oil then drains back into the sump via large drillings in the cylinder head and cylinder block.

12 A pressure relief valve is incorporated in the oil pump, to maintain the oil pressure within specified limits.

13 Apart from minor development differences, both the 2.5 and 2.7 litre versions of the engine are mechanically identical.

## 2 Repair operations possible with the engine in the vehicle

The following operations can be carried out without having to remove the engine from the car:

- Compression pressure - testing.
- Removal and refitting of the timing belt.
- Removal and refitting of the camshaft and tappets.
- Removal and refitting of the cylinder head.
- Removal and refitting of the sump.
- Removal and refitting of the big-end bearings.\*
- Removal and refitting of the piston and connecting rod assemblies.\*
- Removal and refitting of the oil pump.
- Removal and refitting of the engine mountings.
- Removal and refitting of the flywheel or driveplate (after first removing the transmission).

\* In extreme cases caused by a lack of necessary equipment, repair or renewal of piston rings, pistons, connecting rods and big-end bearings is possible with the engine in the vehicle. However, this practice is not recommended, because of the cleaning and preparation work that must be done to the components involved, and because of the amount of preliminary dismantling work required - these operations are therefore covered in Part C of this Chapter.

### Precautionary note

Due to the layout of the V6 engine, and the very limited space available in the engine compartment, access to most components is extremely limited. Although it is physically possible to carry out the operations described above with the engine in the car, the space

restrictions, the number of components that need to be removed for access, and the complications involved when working on an engine of this complexity, may present unforeseen difficulties.

Read through all the relevant procedures and familiarize yourself with what's involved before proceeding; in many instances, it may actually be easier to remove the engine from the car, and carry out the repair with the unit on the bench. Strictly speaking, much of the work described in this Chapter is not for the faint-hearted, and should really only be undertaken by the more experienced DIY owner.

### 3 Compression test - description and interpretation

Refer to Part A, Section 3.

### 4 Top Dead Centre (TDC) for number 1 piston - locating



#### General

1 Top Dead Centre (TDC) is the highest point that each piston reaches as the crankshaft rotates. While each piston reaches TDC both at the top of the compression stroke and again at the top of the exhaust stroke, for the purpose of timing the engine, TDC refers to the piston position (usually No 1 piston) at the top of its compression stroke.

2 It is useful for several servicing procedures to be able to position the engine at TDC.

3 No 1 piston and cylinder are at the right-hand (timing belt) end of the engine (right- and left-hand are always as seen from the driver's seat), on the rear bank (ie under the brake master cylinder). The crankshaft rotates clockwise when viewed from the right-hand side of the vehicle.

#### Locating TDC

4 Remove the small plastic plug from the viewing hole on the front of each timing belt upper cover (see illustration).



4.4 Remove the plastic plug from the viewing hole on each timing belt upper cover

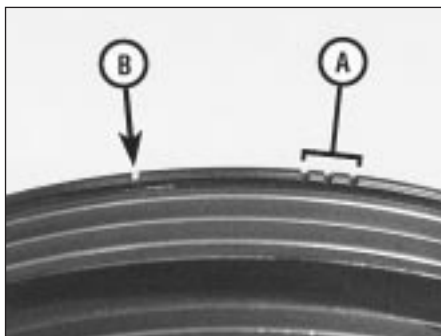

4.6 Ignition timing notches (A) and TDC notch (B) on the crankshaft pulley

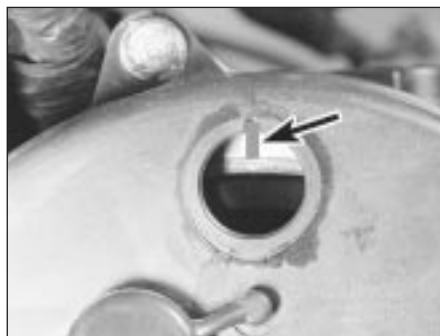

4.8 Paint mark on the camshaft sprocket rim aligned with the notch at on the viewing window



5.5 Lifting off the front camshaft cover

5 Remove the access cover under the right-hand wheelarch.

6 Using a socket and bar on the crankshaft pulley bolt, rotate the crankshaft pulley, in the normal direction of rotation, until a series of very small notches on the pulley inner rim come into view. The first three notches are the ignition timing marks and can be ignored. The next notch (usually coloured white) represents Top Dead Centre (TDC) for No 1 piston on compression, and this is the one we're after (see illustration).

7 Continue turning the crankshaft until the TDC notch is aligned with the pointer on the timing belt cover, just above the pulley. It's best to look down at this from the engine compartment to get the angle right.

8 Now look through the viewing hole on the front timing belt cover. A paint mark on the camshaft sprocket rim should be aligned with the notch at the top of the viewing window (see illustration). If it isn't, turn the crankshaft through one complete revolution and realign the timing marks as before. The mark on the camshaft sprocket should now be correctly aligned. The mark on the rear camshaft sprocket should also be visible through the other window.

9 When all the marks are aligned, the engine is at TDC for No 1 cylinder on compression, and is correctly positioned for any work that requires the timing belt to be disturbed.

10 Refit the plugs to the viewing windows on completion.

5 Undo the two bolts securing each camshaft cover to the cylinder head and lift off the covers (see illustration). Collect the washers under the bolt heads, and remove the cover gaskets.

6 Inspect the cover gasket and the seals on the retaining bolts and renew any that are damaged.

7 Clean the cover and mating faces carefully then, if necessary, fit a new gasket to the cover, ensuring that it locates in the cover grooves.

### Refitting

8 Refitting is a reversal of removal.

3 Withdraw the side covers from the cylinder head being prepared for some oil spillage.

4 Inspect the condition of the cover gasket and renew it if necessary.

5 Clean the cover and mating faces carefully then, if necessary, fit a new gasket to the cover, ensuring that it locates in the cover grooves.

### Refitting

6 Refitting is a reversal of removal. Ensure that the arrow, and the word UP are at the top when refitting each cover (see illustration).

## 6 Cylinder head side covers - removal and refitting

### Removal

1 If the rear cover is being removed, jack up the front of the vehicle and support it on axle stands. Access to the rear cover is marginally better from below.

2 Move the adjacent components clear as much as possible and undo the side cover retaining bolts. Note the oxygen sensor wiring support bracket attachments on one of the lower bolts and the engine earth lead on the upper front cover bolt (see illustration).

## 7 Exhaust valve rocker clearances - adjustment

**Note:** This is not a routine maintenance operation and will only be necessary if the cylinder head, camshafts or any components of the valve train have been disturbed or renewed.

1 Remove the camshaft covers and the cylinder head side covers as described in Sections 5 and 6 respectively.

2 Set the engine to TDC for No 1 cylinder on compression, as described in Section 4.

3 Slacken the rocker arm adjusting screw locknuts for No 1 cylinder exhaust valves on the rear cylinder head.

4 Tighten the adjusting screw until it just contacts the valve, then tighten it a further

## 5 Camshaft covers - removal and refitting

### Removal

1 Release the spark plug HT leads from their clips on the camshaft covers and move the leads to one side.

2 Release the clips and disconnect the breather hoses from the camshaft covers.

3 Disconnect the oil temperature switch wiring multiplug from the rear camshaft cover.

4 Undo the two bolts and detach the pipe support brackets from the rear cover.



6.2 Engine earth lead (arrowed) on the upper front side cover bolt



6.6 Ensure that the arrow, and the word UP are at the top when refitting the side covers



7.4 Exhaust valve rocker clearance adjustment

one and a half turns. Tighten the locknut securely (see illustration).

5 Repeat paragraphs 3 and 4 for No 2 cylinder exhaust valves on the rear cylinder head, and No 4 cylinder exhaust valves on the front cylinder head.

6 Rotate the crankshaft through one complete revolution and realign the timing marks.

7 Repeat paragraphs 3 and 4 for No 5 and No 6 cylinder exhaust valves on the front cylinder head, and No 3 cylinder exhaust valves on the rear cylinder head.

8 Refit the cylinder head side covers and camshaft covers on completion.

## 8 Inlet manifold - removal and refitting



### Removal

1 Drain the cooling system as described in Chapter 1.

2 Disconnect the spark plug HT leads from the spark plugs and cable clips and move the leads clear of the engine. Ensure each lead is labelled to identify its respective spark plug.

3 Refer to Chapter 4, Part D and remove the following components:

- (a) Air cleaner and air intake components (Section 2).
- (b) Throttle body (Section 12).
- (c) Electronic idle control valve (Section 12).
- (c) Fast idle valve (Section 12).
- (d) Front and rear fuel rail and injectors (Section 12).

4 Refer to Chapter 4, Part E and remove the air suction valve pipe.

5 Check that all the vacuum hoses at the pipe cluster are numbered with corresponding numbers on their respective pip stubs. Mark any as necessary, then disconnect all the hoses from the pipe cluster stubs.

6 Check that all pipes, hoses and cables have been disconnected; undo the eight nuts and bolts securing the manifold to the cylinder head.

7 Lift the manifold up and off the engine and recover the two gaskets.

### Refitting

8 Ensure that the manifold and cylinder mating faces are clean then place the manifold on the cylinder head using new gaskets. Secure the manifold with the eight nuts and bolts.

9 Refer to the relevant Parts of Chapter 4 and refit the previously removed components.

10 Reconnect the spark plug leads, then refill the cooling system as described in Chapter 1.

## 9 Exhaust manifold - removal and refitting



**Note:** Never work on or near a hot exhaust system and in particular, the catalytic converter (where fitted).

### Removal

1 If the front manifold is being removed, refer to Chapter 3 and remove the radiator.

2 Jack up the front of the vehicle and support it on axle stands.

3 On the front manifold, undo the two nuts and lift off the small heat shield and the air suction pipe flange. Recover the gasket.

4 Disconnect the oxygen sensor wiring harness connectors and release the wiring from the support brackets.

5 Undo the bolts from the main manifold heatshields and remove the heatshields.

6 Undo the flange nuts and lower the exhaust front pipe from the manifold studs. Recover the gaskets.

7 Undo the seven nuts securing each manifold to its respective cylinder head, and remove the manifold(s).

8 Clean the mating faces of all components and obtain new gaskets prior to refitting.

### Refitting

9 Refitting is a reversal of removal. Refit the radiator as described in Chapter 3 on completion.

## 10 Crankshaft pulley - removal and refitting



### Removal

1 Remove the auxiliary drivebelts for the alternator, power steering and if fitted, the air conditioning compressor as described in Chapter 1.

2 Remove the starter motor as described in Chapter 5.

3 Jack up the front of the car and support it on axle stands.

4 Remove the access panel under the right-hand wheelarch.

5 Using a socket and long handle, undo the crankshaft pulley retaining bolt. Lock the flywheel ring gear, through the starter motor



10.5 Remove the bolt and washer and withdraw the crankshaft pulley

aperture, using a large screwdriver or tool to prevent the crankshaft rotating as the pulley bolt is undone. Remove the bolt and washer (see illustration).

6 Withdraw the pulley from the crankshaft.

### Refitting

7 Refitting is a reversal of removal. Tighten the pulley retaining bolt to the specified torque. Refit the starter motor as described in Chapter 5, and the drivebelts as described in Chapter 1.

## 11 Timing belt covers - removal and refitting



### Upper covers

#### Removal

1 If the covers are being removed for any procedure that will entail disturbing the timing belt, set the engine at TDC with No 1 cylinder on compression, as described in Section 4, before proceeding.

2 Remove the auxiliary drivebelts for the alternator, power steering and if fitted, the air conditioning compressor as described in Chapter 1.

3 Undo the three bolts securing the rear upper cover to the cylinder head (see illustration).

4 Release the wiring harness support clips,

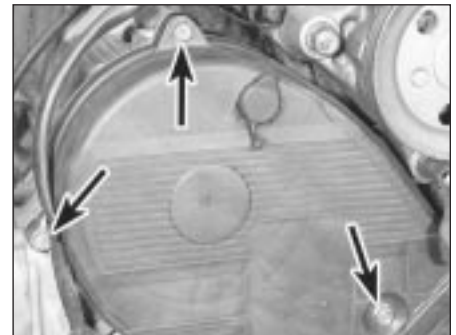

11.3 Timing belt rear upper cover retaining bolts (arrowed)



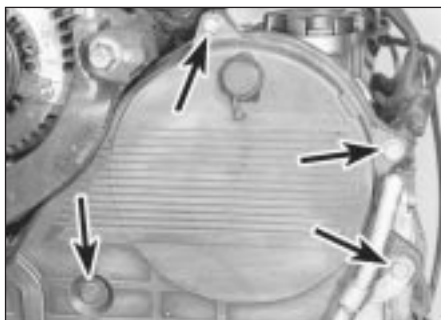

11.5 Timing belt front upper cover retaining bolts (arrowed)

and move the harness clear, then withdraw the rear cover from the engine.

5 Undo the four bolts securing the front cover to the cylinder head (see illustration).

6 Undo the dipstick tube bolt and remove the front cover from the engine.

### Refitting

7 Refitting is a reversal of removal, but ensure that the lip on the cover lower edge engages behind the lower cover (see illustration). Refit the drivebelts as described in Chapter 1.

### Lower cover

#### Removal

8 Remove the upper covers as described previously.

9 Remove the crankshaft pulley as described in Section 10.



11.11 Release the rubber grommet from the protruding head of the timing belt tensioner retaining bolt



11.23 Remove the belt guide from the crankshaft sprocket



11.7 Ensure that the lip on the upper cover lower edge engages behind the lower cover

10 Undo the eight bolts securing the lower cover to the engine (see illustration).

11 Release the rubber grommet from the protruding head of the timing belt tensioner retaining bolt (see illustration).

12 Undo the two bolts from the air conditioner compressor bracket and remove the drivebelt tensioner from the compressor bracket.

13 Withdraw the lower cover from the engine.

### Refitting

14 Refitting is a reversal of removal.

## 12 Timing belt - removal, refitting and adjustment



**Note:** Access may be improved if the coolant is drained and the expansion tank is removed (see Chapter 1).

### Removal

1 Remove the timing belt upper and lower covers, as described in Section 11. Note that it will be necessary to support the engine, and remove the bolts from the right-hand engine mounting, to allow auxiliary drivebelt removal (see Chapter 1).

2 Slacken the timing belt tensioner retaining bolt and move the tensioner, against the pressure of the spring, to the fully released position. Tighten the bolt to hold the tensioner in this position.



12.4 Timing belt arrangement around the sprockets, pulley and tensioner

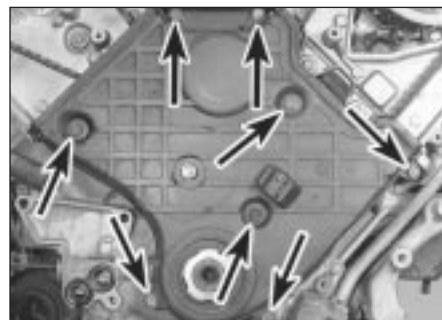

11.10 Timing belt lower cover retaining bolts (arrowed)

3 Remove the belt guide from the crankshaft sprocket noting that it is fitted with its concave side facing outwards (see illustration).

4 Sketch the timing belt arrangement around the sprockets, water pump pulley and tensioner, as a guide when refitting (see illustration).

5 Ease the belt off the camshaft sprockets, then the water pump pulley and tensioner and finally, the crankshaft sprocket (see illustration). Remove the belt from the engine.

6 If the timing belt is to be re-used, mark its running direction with an arrow in chalk, and store it on its edge while it is off the engine.

7 Check the belt for any sign of cracks or splits, particularly around the roots of the teeth. Renew the belt if wear is obvious, if there are signs of oil contamination, or if the belt has exceeded its service interval (see Chapter 1). Also renew the sprockets if they show any signs of wear or chipping of the teeth.

8 Check the tensioner and sprockets as described in Section 13.

9 Before refitting the belt, check that the engine is still at TDC with No 1 cylinder on compression (Section 4) as it will probably have moved when the crankshaft pulley was removed. Use a screwdriver engaged with the flywheel teeth to move the crankshaft as necessary, and move the camshafts by means of their sprockets. With the covers removed, it is possible to see the mark or notch on the ends of the camshaft sprockets, which should be aligned with the corresponding line in the backplate (see



12.5 Ease the belt off the camshaft sprockets





12.9a Front camshaft sprocket timing mark, aligned with the corresponding line in the backplate



12.9b Rear camshaft sprocket timing notch, aligned with the corresponding line in the backplate

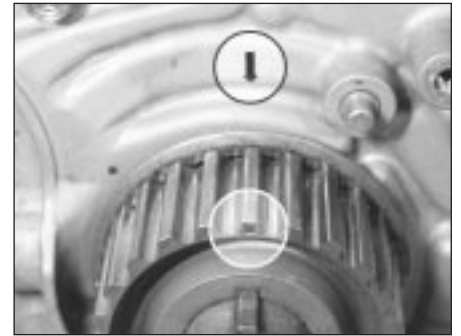

12.9c Notch on the front of the crankshaft sprocket aligned with the arrow cast into the oil pump housing

illustrations). Similarly, there is a notch on the front of the crankshaft sprocket which should align with an arrow cast into the oil pump housing (see illustration).

### Refitting and adjustment

10 Feed the timing belt around the sprockets, starting with the crankshaft sprocket, then, keeping it taut, feed it over the front camshaft sprocket, water pump pulley, rear camshaft sprocket, and tensioner pulley.

11 Slacken the timing belt tensioner retaining bolt, allow the tensioner to automatically tension the belt, then re-tighten the bolt.

12 Refit the belt guide to the crankshaft sprocket noting that it is fitted with its concave side facing outwards.

13 Check that the timing marks are still aligned with the engine at TDC, then refit the timing belt covers and crankshaft pulley.

14 Turn the engine over by means of the crankshaft pulley bolt to settle the belt on the sprockets. Return the crankshaft to TDC for No 1 cylinder on compression.

15 Now turn the crankshaft further by approximately nine teeth on the camshaft sprocket until an additional notch (usually coloured blue) is aligned with the pointer on the lower cover.

16 Slacken the timing belt tensioner bolt, then retighten it once more.

17 Turn the crankshaft further to return it to the TDC position for No 1 cylinder on

compression, and check that all the timing marks, on the pulley and camshaft sprockets are aligned as previously described. If they are all is well. If not, the belt is probably a tooth out and should be repositioned as previously described.

18 Refit the plugs to the upper covers, then refit the auxiliary drivebelts as described in Chapter 1.

### 13 Timing belt tensioner and sprockets - removal, inspection and refitting



#### Tensioner

##### Removal

1 Remove the timing belt as described in Section 12.

2 Unhook the tensioner spring from the anchorage stud.

3 Remove the tensioner retaining bolt, lift off the tensioner and remove the spring (see illustration).

##### Inspection

4 Spin the tensioner, and ensure that there is no roughness or harshness in the bearing. Also check that the endfloat is not excessive and there is no sign of free play. Check the surface of the tensioner for any signs of roughness, nicks or scoring which may

damage the timing belt. Renew the tensioner if worn.

##### Refitting

5 Refitting is a reversal of removal, but ensure that the lower tensioner arm engages over the lug in the casing (see illustration).

#### Camshaft sprockets

##### Removal

6 Remove the timing belt as described in Section 12.

7 Undo the three retaining bolts securing each sprocket to its respective camshaft. To prevent the sprockets turning as the bolts are undone, either insert a large screwdriver through one of the sprocket holes and engage it with one of the backplate bolts behind, or make up a holding tool from scrap metal, which is of a scissor shape, with a bolts at each end to engage with the holes in the sprocket (see illustration).

8 Withdraw the two sprockets from the camshafts, noting their orientation; the sprocket with the flanged edge is fitted to the front camshaft, and the sprocket with the spokes is fitted to the rear camshaft.

##### Inspection

9 Check the condition of the sprockets, inspecting carefully for any wear grooves, pitting or scoring around the teeth, or any wear ridges which might cause damage to the timing belt. Make sure that the dowels are not



13.3 Remove the tensioner retaining bolt, lift off the tensioner and remove the spring



13.5 Ensure that the lower tensioner arm engages over the lug in the casing when refitting



13.7 Use a tool like this to hold the camshaft sprocket as the bolts are undone



14.2 Front cylinder head backplate retaining bolts (arrowed)

worn and are not a loose fit in the camshaft or sprocket holes.

### Refitting

10 Refitting is a reversal of removal. Ensure that the sprockets are fitted to their correct camshafts and tighten the retaining bolts to the specified torque.

### Crankshaft sprocket

#### Removal

11 Remove the timing belt as described in Section 12.

12 Slide the sprocket off the front of the crankshaft followed by the timing belt guide behind.

#### Inspection

13 Check the condition of the sprocket, inspecting carefully for any wear grooves, pitting or scoring around the teeth, or any wear ridges which might cause damage to the timing belt. Examine the Woodruff key and its groove and make sure it is a tight fit.

### Refitting

14 Refitting is a reversal of removal.

### 14 Camshaft oil seals - renewal



**Note:** The use of an oil seal extractor which screws into the seal inside circumference is preferable for this operation. These are available at most accessory shops and can often be hired from tool hire outlets. In the absence of this type of tool, an alternative (but less satisfactory) method of removal is described in the following procedure.

1 Remove the camshaft sprockets as described in the previous Section.

2 Undo the retaining bolts and remove the backplate from the front or rear cylinder head as required (see illustration).

3 The oil seals are now accessible for removal. Punch or drill two small holes opposite each other in the oil seal. Screw a self-tapping screw into each hole and pull on the screws with pliers to extract the seal.

4 Check that the housing is clean before

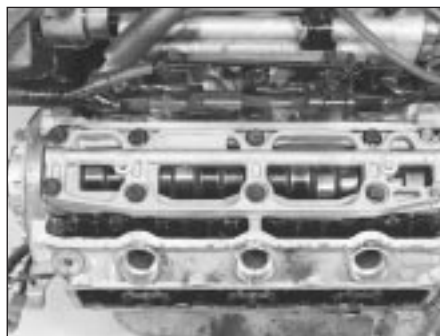

15.8 Undo the ten bolts securing the oil gallery to the camshaft carrier

fitting the new seal. Lubricate the lips of the seal and the running faces of the camshaft with clean engine oil, then carefully locate the seal over the camshaft and drive it squarely into position using a tube or a socket. Take care not to turn over the lips of the seal as it is being fitted. Another method of fitting is to draw it squarely into position using the sprocket bolt and a distance piece.

5 With the seal fully inserted in its housing, refit the backplate, then refit the camshaft sprocket as described in the previous Section.

### 15 Camshaft and hydraulic tappets - removal, inspection and refitting



#### Removal

1 Remove the air cleaner assembly and air intake trunking as described in Chapter 4, Part D.

2 Remove the camshaft covers as described in Section 5.

3 Remove the cylinder head side covers as described in Section 6.

4 Remove the camshaft sprocket(s) as described in Section 13.

5 If working on the front camshaft, remove the distributor as described in Chapter 5.

6 If working on the rear camshaft, remove the power steering pump as described in Chapter 10.

7 Undo the retaining bolts and remove the



15.11 Lift the camshaft carrier off the cylinder head



15.9 Recover the small O-ring seal in the camshaft carrier

backplate from the front or rear cylinder head as required.

8 Undo the ten bolts securing the oil gallery to the camshaft carrier noting the locations of the two short bolts (see illustration).

9 Lift off the oil gallery and recover the small O-ring seal in the camshaft carrier (see illustration).

10 If working on the front camshaft, undo the two small camshaft carrier retaining bolts at each end.

11 Lift the camshaft carriers off the cylinder head (see illustration).

12 Carefully lift out the camshafts, marking or labelling them FRONT or REAR as applicable (see illustration).

13 Withdraw the oil seal off the front of the camshaft.

14 If working on the rear camshaft, remove the end plug from the cylinder head.

15 Obtain a compartmented box, and mark it inlet and exhaust for each cylinder (ie 1 INLET, 1 EXHAUST, 2 INLET, 2 EXHAUST etc).

16 Lift out the slippers, tappets and pushrods for each cylinder, in turn, and place the components in their respective compartments in the box (see illustration).

#### Inspection

17 Clean and inspect the various components removed, for signs of excessive wear.

18 Examine the camshaft bearing journals and lobes for damage or obvious wear. If evident, a new camshaft must be fitted, or one that has been renovated by a company



15.12 Carefully lift out the camshafts



15.16a Lift out the rocker arms . . .



15.16b . . . and hydraulic tappets



15.18 Measure the camshaft journal diameters using a micrometer

specialising in exchange components. If the camshaft appears sound, measure the journal diameters using a micrometer (see illustration).

19 The camshaft bearing bore diameters in the cylinder head should be measured and checked against the tolerances specified. A gauge will be required for this but if not available, check for excessive movement between the camshaft journals and the bearings. Alternatively, the Plastigage method, described in Part C of this Chapter, for main and big-end bearing running clearance checks, can be used. If the bearings are found to be unacceptably worn, either a new camshaft or a new cylinder head is the only answer as the bearings are machined directly in the head.

20 It is seldom that the hydraulic tappets are badly worn in the cylinder head bores but again, if the tappets are scored, or the bores are found to be worn beyond an acceptable level, either the tappet(s) or the complete cylinder head must be renewed. If any of the tappets have been noisy in operation, or their internal condition is suspect, perform a tappet seating stroke check as described below.

21 If the contact surface of the cam lobes show signs of depression or grooving, note that they cannot be renovated by grinding as the hardened surface will be removed and the overall length of the tappet(s) will be reduced. The self-adjustment point of the tappet will be exceeded as a result, so that the valve adjustment will be affected and they will then

be noisy in operation. Therefore, renewal of the camshaft is the only remedy in this case.

22 Check the rocker arms for signs of scoring on their contact faces and for any visible signs of wear on the pushrods. Renew any that are noticeably worn or damaged.

### Tappet seating stroke check

23 Carry out this check if any of the tappets have been noisy in operation, or their internal condition is suspect.

24 Using a small drill bit that will just fit through the hole in the end of the tappet, immerse the tappet in a small container of clean engine oil so that the tappet is submerged. Insert the drill bit through the hole in the tappet ball end and push the valve inside the tappet in and out several times, using a slow pumping action, to remove all air from the tappet (see illustrations).

25 Remove the tappet from the container and place it on the bench with the ball end uppermost.

26 Mount a dial gauge and test stand over the tappet with the dial gauge probe in contact with the tappet ball end. Zero the gauge.

27 Push the ball end down quickly by hand and note the reading on the dial gauge. This is the tappet seating stroke and, if it is outside the maximum figure given in the Specifications, renew the tappet.

28 After checking, the tappet must be drained of oil so as to be fitted dry on reassembly.

**Caution:** On reassembly, do not fit a tappet that is full of oil from the seating stroke check, otherwise there is a possibility of the valves being held open on initial cranking.

29 Turn the tappet upside down and, using the small drill bit, depress the internal valve to drain the oil from the tappet (see illustration).

30 Repeat the above procedure on any other suspect tappets.

### Refitting

31 Refitting is a reversal of removal, bearing in mind the following points:

- (a) Fill the tappet bores to oil path level before fitting the tappets and do not rotate them once in position (see illustration).



15.24b . . . immerse the tappet in oil and push the valve inside in and out to remove all the air



15.29 Depress the internal tappet valve to drain the oil prior to installation



15.31a Fill the tappet bores with oil before fitting the tappets





15.31b Prime the tappet oil feeds in the cylinder head with oil

- (b) Prime the tappet oil feeds in the cylinder head with oil (see illustration).
- (c) Apply RTV sealant to the ends of the camshaft carrier before refitting (see illustration).
- (d) Use new gaskets on all joints and tighten the retaining nuts and bolts to the specified torque where given. Tighten the oil gallery bolts in the sequence shown (see illustration).
- (e) Refit all components removed for access as described in the relevant Sections and Chapters of this manual.

### 16 Cylinder head - removal and refitting



#### Removal

- 1 Remove the inlet manifold as described in Section 8.
- 2 Remove the camshaft and hydraulic tappets on the side concerned as described in Section 15.
- 3 Undo the flange bolts and remove the exhaust front pipes from the exhaust manifolds. Recover the flange gaskets.
- 4 Undo the bolts securing the coolant connecting pipe. Disconnect the temperature sensor wiring multiplug, move the wiring harness aside and remove the connecting pipe. Recover the sealing O-rings from the pipe.
- 5 If removing the front cylinder head,

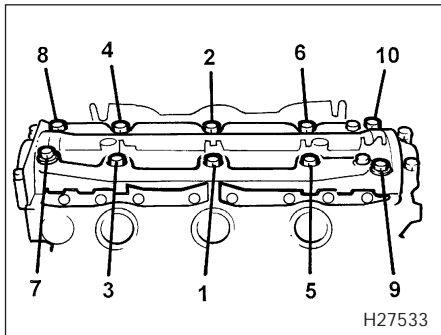

15.31d Oil gallery retaining bolt tightening sequence

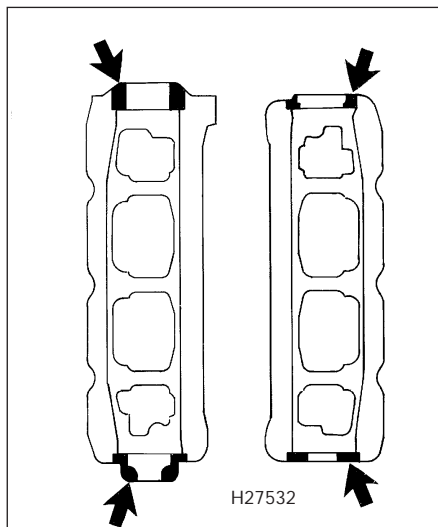

15.31c Apply RTV sealant to the ends of the camshaft carrier (shown shaded) before refitting

disconnect the camshaft sensor wiring multiplug (where fitted).

- 6 If not already removed, remove the push rods from their locations and place them in a marked box to indicate their respective cylinders.
- 7 Progressively slacken the cylinder head retaining bolts a third of a turn at a time, in the sequence shown until all are slack, then remove the bolts (see illustration).
- 8 Lift the cylinder head off the locating dowels and remove it from the engine. If the head is stuck, it can be carefully levered up using a large screwdriver between the cylinder block and the protruding cylinder head flanges. Do not insert the screwdriver under the head-to-block mating face. Place the head on blocks on the bench to protect the valves.
- 9 Remove the cylinder head gasket from the block.
- 10 Prior to refitting, ensure that the cylinder block and head mating faces are thoroughly clean and dry, with all traces of old gasket removed. Clean the threads of the retaining bolts, and remove any oil, water and thread sealer from the bolt holes.

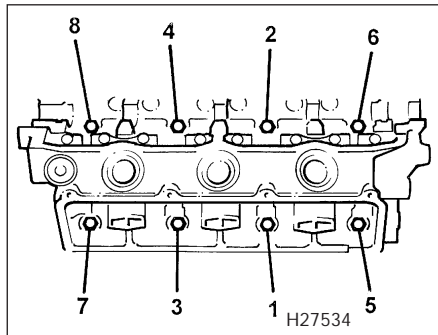

16.7 Cylinder head bolt slackening and tightening sequence

#### Refitting

- 11 Locate a new gasket over the dowels on the cylinder block.
- 12 Lower the cylinder head assembly onto the gasket, and refit the retaining bolts. Working in the sequence shown, tighten the retaining bolts to the specified torque (see illustration 16.7). Note that the cylinder head bolt slackening and tightening sequence are the same.
- 13 The remainder of refitting is a reversal of removal but refer to the relevant Sections and Chapters of this manual for adjustment details.

### 17 Sump - removal and refitting

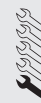

#### Removal

- 1 Disconnect the battery negative (earth) lead (refer to Chapter 5, Section 1).
- 2 Apply the handbrake, jack up the front of the car and support it on axle stands.
- 3 Drain the engine oil as described in Chapter 1.
- 4 Remove the exhaust front pipe with reference to Chapter 4, Part D.
- 5 Undo the bolts securing the longitudinal support member to the underbody beneath the engine, and remove the member.
- 6 Undo the six nuts and sixteen bolts securing the sump to the crankcase.
- 7 Withdraw the sump from the crankcase, tapping it from side to side with a hide or plastic mallet if it is stuck. Recover the sump gasket.
- 8 If the oil pick-up tube and strainer are to be removed, undo the two bolts securing the strainer bracket to the crankcase, and the two bolts securing the pick-up tube flange to the oil pump.
- 9 Remove the pick-up pipe and tube from the crankcase. Recover the O-ring from the pick-up pipe flange. Remove the baffle plate from the cylinder block.
- 10 Clean the sump, and the mating faces of both the sump and crankcase thoroughly.
- 11 If removed, clean the pick-up pipe, and the filter gauze in the strainer.

#### Refitting

- 12 Refitting is a reversal of removal. Use a new sump gasket and O-ring seal on the pick-up pipe flange and tighten the sump retaining nuts and bolts progressively to the specified torque. Fill the engine with oil as described in Chapter 1 on completion.

### 18 Oil cooler and filter head - removal and refitting

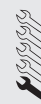

#### Removal

- 1 Drain the cooling system as described in Chapter 1.





**18.8 Removing the oil cooler and filter head assembly**

- 2 Jack up the front of the car and support it on axle stands.
- 3 Remove the right-hand front road wheel and the access panel under the wheelarch.
- 4 Place a jack with interposed block of wood under the sump and just take the weight of the engine.
- 5 Undo the two right-hand engine mounting retaining bolts.
- 6 Lower the jack slightly to provide access to the oil cooler and filter head assembly from under the wheelarch.
- 7 Undo the three bolts securing the assembly to the front of the engine.
- 8 Withdraw the assembly from the engine, and disconnect the oil pressure switch wiring and the two coolant hoses (see illustration).
- 9 Recover the double O-ring seal from the filter housing outlets on the engine (see illustration).
- 10 With the assembly on the bench, undo the centre bolt from the oil cooler and remove the cooler from the filter head. Recover the O-rings.

### Refitting

11 Refitting is a reversal of removal, but lubricate the O-rings prior to fitting. Fill the cooling system and top-up the engine oil as described in Chapter 1, on completion.

## 19 Oil pump - removal and refitting



### Removal

- 1 Drain the engine oil as described in Chapter 1.
- 2 Remove the timing belt as described in Section 12.
- 3 Remove the crankshaft sprocket and the timing belt tensioner as described in Section 13.
- 4 Remove the timing belt inner guide from the front of the crankshaft.
- 5 Unscrew the timing belt tensioner spring anchorage stud from the oil pump housing.
- 6 Remove the oil cooler and filter head as described in Section 18.

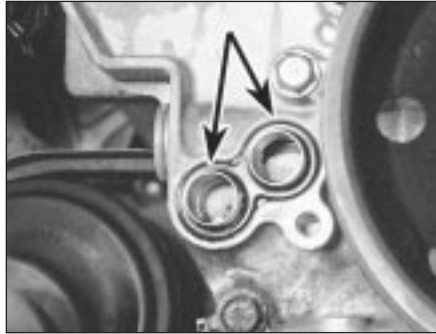

**18.9 Recover the double O-ring seal from the filter housing outlets**

- 7 Support the engine from above using a crane and chains or sturdy slings attached to suitable anchorage points on the engine.
- 8 Remove the jack from under the sump (from the previous operation) then remove the sump and oil pick-up strainer as described in Section 17.
- 9 Undo the retaining bolt and remove the dipstick tube. Recover the O-ring.
- 10 Undo the two bolts from the oil feed tube and remove the tube. Recover the O-rings.
- 11 Undo the nine oil pump housing retaining bolts, noting the locations of the two longer bolts (see illustration).
- 12 Release the pump housing from the dowels and remove it from the engine.
- 13 Clean off all traces of sealant on the pump housing and cylinder block mating faces prior to reassembly.

### Refitting

14 Refitting is a reversal of removal. Apply a bead of RTV sealant to the housing mating face, inside the line of bolt holes and tighten the retaining bolts to the specified torque. Use new O-rings on all components.

## 20 Crankshaft oil seals - renewal



### Front oil seal

- 1 Remove the timing belt as described in Section 12.
- 2 Withdraw the sprocket from the crankshaft together with the timing belt guide plate.
- 3 Remove the Woodruff key from the slot in the crankshaft.
- 4 Note the fitted depth of the oil seal in relation to the front of the housing as an aid to refitting.
- 5 Punch or drill two small holes opposite each other in the seal. Screw a self tapping screw into each, and pull on the screws with pliers to extract the seal.
- 6 Clean the seal location in the pump housing, and clean off any burrs or raised edges, which may have caused the seal to fail.



**19.11 Oil pump housing location on the front of the engine**

- 7 Lubricate the lips of the new seal with clean engine oil and carefully locate the seal over the crankshaft and into the housing.
- 8 Using a tubular drift which bears on the hard outer edge of the seal, drive the seal into the housing to the previously noted depth.
- 9 Refit the Woodruff key to the crankshaft.
- 10 Refit the timing belt guide plate and sprocket to the crankshaft.
- 11 Refit the timing belt as described in Section 12.

### Rear oil seal

- 12 Remove the flywheel/driveplate as described in Section 22.
- 13 Punch or drill two small holes opposite each other in the seal. Screw a self tapping screw into each, and pull on the screws with pliers to extract the seal.
- 14 Clean the seal housing, and polish off any burrs or raised edges, which may have caused the seal to fail in the first place.
- 15 Lubricate the lips of the new seal with clean engine oil and carefully locate the seal on the end of the crankshaft.
- 16 Using a large tubular drift bearing on the hard outer edge of the seal, drive the seal into the housing until it is flush with the housing face.
- 17 Clean off any surplus oil then refit the flywheel/driveplate as described in Section 22.

## 21 Engine/transmission mountings - inspection and renewal

Refer to Part A, Section 18.

## 22 Flywheel/driveplate - removal, inspection and refitting



### Removal

- 1 With the engine removed from the car and separated from the transmission, or with the

## 2B•12 V6 engine - in-car engine repair procedures

---

transmission removed as described in Chapter 7, remove the clutch assembly (manual transmission) as described in Chapter 6.

**2** Undo the eight flywheel/driveplate retaining bolts. To prevent the flywheel turning, lock the ring gear teeth using a small strip of angle iron engaged in the teeth and against, or screwed into, a transmission-to-engine retaining bolt inserted into a vacant bolt hole.

**3** Lift off the washer plate (automatic transmission), then withdraw the flywheel/driveplate from the crankshaft.

### **Inspection**

**4** Inspect the starter ring gear on the flywheel or driveplate for wear or broken teeth. If evident, the ring gear should be renewed. This is a specialist operation and should be entrusted to a Rover dealer.

**5** The clutch friction surface on the flywheel should be checked for grooving or cracks, the latter being caused by overheating. If these conditions are evident, renewal of the flywheel is necessary.

### **Refitting**

**6** Refitting is a reversal of removal, tightening the bolts to the specified torque in a diagonal and progressive sequence.

# Chapter 2 Part C: Engine removal and general engine overhaul procedures

## Contents

Crankshaft - inspection	17	Engine overhaul - reassembly sequence	19
Crankshaft - refitting and main bearing running clearance check	21	Engine removal - methods and precautions	3
Crankshaft (4-cylinder engine) - removal	13	Engine/transmission (4-cylinder engine) - removal, separation and refitting	4
Crankshaft (V6 engine) - removal	14	Engine/transmission (V6 engine) - removal, separation and refitting	5
Cylinder block/crankcase - cleaning and inspection	15	General information	1
Cylinder head - reassembly	10	Main and big-end bearings - inspection	18
Cylinder head (4-cylinder engine) - dismantling	7	Piston/connecting rod assemblies - inspection	16
Cylinder head and rocker gear (V6 engine) - dismantling	8	Piston/connecting rod assemblies - refitting and big-end bearing running clearance check	22
Cylinder head, rocker gear and valve assemblies - cleaning and inspection	9	Piston/connecting rod assemblies (4-cylinder engine) - removal	11
Engine - initial start-up after overhaul	23	Piston/connecting rod assemblies (V6 engine) - removal	12
Engine overhaul - dismantling sequence	6	Piston rings - refitting	20
Engine overhaul - general information	2		

## Degrees of difficulty

<b>Easy</b> , suitable for novice with little experience 	<b>Fairly easy</b> , suitable for beginner with some experience 	<b>Fairly difficult</b> , suitable for competent DIY mechanic 	<b>Difficult</b> , suitable for experienced DIY mechanic 	<b>Very difficult</b> , suitable for expert DIY or professional 
--	---	---	--	---

## Specifications

### 4-cylinder engines

#### Cylinder head

Valve seat angle (inlet and exhaust)	45°
Valve seat width (inlet and exhaust)	1.5 to 2.0 mm

#### Valves

	Inlet	Exhaust
Valve stem diameter	7.09 to 7.10 mm	7.07 to 7.09 mm
Valve head diameter	31.7 to 31.9 mm	29.2 to 29.4 mm
Valve stem-to-guide clearance	0.04 to 0.06 mm	0.06 to 0.07 mm
Valve spring free length:		
"M" series engines	41.0 mm	
"T" series engines	46.2 mm	

#### Pistons and piston rings

##### Piston-to-cylinder bore clearance:

"M" series engines:	
Top of skirt	0.08 to 0.10 mm
Bottom of skirt	0.04 to 0.05 mm
"T" series engines	
	0.01 to 0.03 mm

##### Piston ring end gap - installed:

"M" series engines:	
Compression rings	0.30 to 0.50 mm
Oil control ring	0.25 to 0.50 mm
"T" series engines:	
Top compression	0.25 to 0.35 mm
2nd compression	0.30 to 0.50 mm
Oil control	0.30 to 0.50 mm

##### Piston ring-to-groove clearance:

Top compression	0.06 to 0.09 mm
2nd compression	0.05 to 0.07 mm

### Cylinder block

Cylinder bore diameter	84.456 to 84.469 mm
Maximum cylinder bore taper	0.15 mm
Maximum cylinder bore ovality	0.15
Maximum gasket face distortion	0.10 mm

### Crankshaft and bearings

Main bearing journal diameter	54.005 to 54.026 mm
Main bearing journal-to-shell running clearance	0.03 to 0.070 mm
Crankpin (big-end) bearing journal diameter	47.648 to 47.661 mm
Crankpin (big-end) bearing journal-to-shell running clearance	0.04 to 0.08 mm
Crankshaft endfloat	0.03 to 0.20 mm

**Note:** Refer to Part A of this Chapter for torque wrench settings.

### V6 engines

#### Cylinder head

Valve seat angle (inlet and exhaust)	45°
Valve seat width (inlet and exhaust)	2.0 mm maximum

#### Valves

	Inlet	Exhaust
Valve stem diameter	6.58 to 6.59 mm	6.55 to 6.58 mm
Valve stem-to-guide clearance	0.16 mm maximum	0.22 mm maximum

#### Cylinder block

Cylinder bore diameter	87.00 to 87.02 mm
Maximum cylinder bore taper	0.05 mm
Maximum cylinder bore ovality	0.05 mm
Maximum gasket face distortion	0.10 mm

#### Pistons and piston rings

Piston-to-cylinder bore clearance	0.08 mm
Piston ring end gap:	
Top compression	0.35 mm maximum
2nd compression	0.50 mm maximum
Oil control ring	0.70 mm maximum
Piston ring-to-groove clearance	No information available

#### Crankshaft and bearings

Main bearing journal-to-shell running clearance	0.24 to 0.048 mm
Main bearing journal taper and ovality	0.010 mm maximum
Crankpin (big-end) bearing journal-to-shell running clearance	0.026 to 0.050 mm
Crankpin (big-end) bearing journal taper and ovality	0.010 mm maximum
Crankshaft endfloat	0.10 to 0.30 mm

**Note:** Refer to Part B of this Chapter for torque wrench settings.

## 1 General information

### How to use this Chapter

This Part of Chapter 2 is devoted to engine/transmission removal and refitting, to those repair procedures requiring the removal of the engine/transmission from the vehicle, and to the overhaul of engine components. It includes only the Specifications relevant to those procedures. Refer to Parts A and B for additional Specifications, if required.

### General information

The information ranges from advice concerning preparation for an overhaul and the purchase of replacement parts, to detailed step-by-step procedures covering removal

and installation of internal engine components and the inspection of parts.

The following Sections have been written based on the assumption that the engine has been removed from the vehicle. For information concerning in-vehicle engine repair, as well as removal and installation of the external components necessary for the overhaul, see Parts A and B of this Chapter and Section 6 of this Part.

When overhauling the engine, it is essential to establish first exactly what replacement parts are available. On some of the engines covered in this Chapter, components such as the piston rings are not available separately from the piston/connecting rod assemblies; pistons, gudgeon pins and valve guides may also not be available separately as may some under- or oversized components. In some cases, depending on the extent of engine wear, it would appear that the easiest and

most economically-sensible course of action is to replace a worn or damaged engine with an exchange unit.

## 2 Engine overhaul - general information

It's not always easy to determine when, or if, an engine should be completely overhauled, as a number of factors must be considered.

High mileage is not necessarily an indication that an overhaul is needed, while low mileage doesn't preclude the need for an overhaul. Frequency of servicing is probably the most important consideration. An engine that's had regular and frequent oil and filter changes, as well as other required maintenance, will most likely give many



thousands of miles of reliable service. Conversely, a neglected engine may require an overhaul very early in its life.

Excessive oil consumption is an indication that piston rings, valve seals and/or valve guides are in need of attention. Make sure that oil leaks aren't responsible before deciding that the rings and/or guides are worn. Perform a cylinder compression check to determine the extent of the work required.

Loss of power, rough running, knocking or metallic engine noises, excessive valve train noise and high fuel consumption rates may also point to the need for an overhaul, especially if they're all present at the same time. If a full service doesn't remedy the situation, major mechanical work is the only solution.

An engine overhaul involves restoring all internal parts to the specification of a new engine. **Note:** *Always check first what replacement parts are available before planning any overhaul operation; refer to Section 1 of this Part. Rover dealers, or a good engine reconditioning specialist/automotive parts supplier may be able to suggest alternatives which will enable you to overcome the lack of replacement parts.*

During an overhaul, it is usual to renew the piston rings, and to rebore and/or hone the cylinder bores; where the rebore is done by an automotive machine shop, new oversize pistons and rings will also be installed - all these operations, of course, assume the availability of replacement parts. The main and big-end bearings are generally renewed and, if necessary, the crankshaft may be reground to restore the journals. Generally, the valves are serviced as well, since they're usually in less-than-perfect condition at this point. While the engine is being overhauled, other components, such as the starter and alternator, can be renewed as well, or rebuilt, if the parts can be found. The end result should be an as-new engine that will give many trouble-free miles. **Note:** *Critical cooling system components such as the hoses, drivebelt, thermostat and water pump MUST be replaced with new parts when an engine is overhauled. The radiator should be checked carefully, to ensure that it isn't clogged or leaking (see Chapter 3). Also, as a general rule, the oil pump should be renewed when an engine is rebuilt.*

Before beginning the engine overhaul, read through the entire procedure to familiarise yourself with the scope and requirements of the job. Overhauling an engine isn't difficult, but it is time-consuming. Plan on the vehicle being off the road for a minimum of two weeks, especially if parts must be taken to an automotive machine shop for repair or reconditioning. Check on availability of parts, and make sure that any necessary special tools and equipment are obtained in advance. Most work can be done with typical hand tools, although a number of precision measuring tools are required, for inspecting

parts to determine if they must be replaced. Often, an automotive machine shop will handle the inspection of parts, and will offer advice concerning reconditioning and replacement. **Note:** *Always wait until the engine has been completely dismantled, and all components, especially the cylinder block/crankcase, have been inspected, before deciding what service and repair operations must be performed by an automotive machine shop. Since the block's condition will be the major factor to consider when determining whether to overhaul the original engine or buy a rebuilt one, never purchase parts or have machine work done on other components until the cylinder block/crankcase has been thoroughly inspected.* As a general rule, time is the primary cost of an overhaul, so it doesn't pay to install worn or sub-standard parts.

As a final note, to ensure maximum life and minimum trouble from a rebuilt engine, everything must be assembled with care, in a spotlessly-clean environment.

### 3 Engine removal - methods and precautions

If you've decided that an engine must be removed for overhaul or major repair work, several preliminary steps should be taken.

Locating a suitable place to work is extremely important. Adequate work space, along with storage space for the vehicle, will be needed. If a workshop or garage isn't available, at the very least, a flat, level, clean work surface made of concrete or asphalt is required.

Cleaning the engine compartment and engine/transmission before beginning the removal procedure will help keep tools clean and organised.

An engine hoist or A-frame will be necessary. Make sure the equipment is rated in excess of the combined weight of the engine and transmission. Safety is of primary importance, considering the potential hazards involved in removing the engine/transmission from the vehicle.

If this is the first time you have removed an engine, a helper should ideally be available. Advice and aid from someone more experienced would also be helpful. There are many instances when one person cannot simultaneously perform all of the operations required when removing the engine/transmission from the vehicle.

Plan the operation ahead of time. Arrange for, or obtain, all of the tools and equipment you'll need prior to beginning the job. Some of the equipment necessary to perform engine/transmission removal and installation safely and with relative ease, and which may have to be hired or borrowed, includes (in addition to the engine hoist) a heavy-duty

trolley jack, a strong pair of axle stands, some wooden blocks, and an engine dolly (a low, wheeled platform capable of taking the weight of the engine/transmission, so that it can be moved easily when on the ground). A complete set of spanners and sockets (as described in the front of this manual) will obviously be needed, together with plenty of rags and cleaning solvent for mopping-up spilled oil, coolant and fuel. If the hoist is to be hired, make sure that you arrange for it in advance, and perform all of the operations possible without it beforehand. This will save you money and time.

Plan for the vehicle to be out of use for quite a while. A machine shop will be required to perform some of the work which the do-it-yourselfer can't accomplish without special equipment. These establishments often have a busy schedule, so it would be a good idea to consult them before removing the engine, to accurately estimate the amount of time required to rebuild or repair components that may need work.

Always be extremely careful when removing and installing the engine/transmission. Serious injury can result from careless actions. By planning ahead and taking your time, the job (although a major task) can be accomplished successfully.

### 4 Engine/transmission (4-cylinder engine) - removal, separation and refitting



**Note:** *The engine can be removed from the car only as a complete unit with the transmission; the two are then separated for overhaul. The engine/transmission are removed upwards and out from the top of engine compartment.*

#### Removal

- 1 Extract the retaining clips and release the support struts from the bonnet. Tie the bonnet back in the fully-open position.
- 2 Drain the cooling system, the engine oil, and the transmission oil or fluid as described in Chapter 1.
- 3 Remove the complete air cleaner and intake trunking assembly, as described in the relevant Part of Chapter 4.
- 4 Remove the battery as described in Chapter 5, then undo the three bolts and remove the battery tray.
- 5 Undo the three bolts and remove the air cleaner support bracket, located below the battery tray.
- 6 On cars with single-point fuel injection, undo the three ignition/fuel ECU mounting bracket bolts, and move the ECU and bracket aside.
- 7 Slacken the clips and remove the radiator top hose, then disconnect the expansion tank hose at the thermostat housing. On single-point injection models, disconnect the two heater outlet hoses at the inlet manifold.

## 2C•4 Engine removal and general engine overhaul procedures



**4.9** Undo the bolt (arrowed) securing the engine rear tie-bar support bracket to the inlet manifold

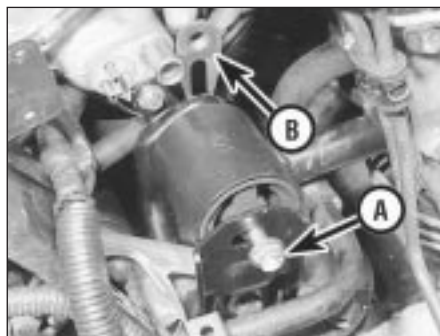

**4.10** Remove the tie-bar through-bolt (A) and recover the forked nut (B)



**4.12a** Disconnect the radiator hose (arrowed) at the main coolant pipe . . .

**8** Disconnect the remaining vacuum hose at the inlet manifold.

**9** Undo the bolt securing the engine rear tie-bar support bracket to the inlet manifold (see illustration).

**10** Undo the two through-bolts securing the engine rear tie-bar to the engine and body brackets, and recover the special forked nut (see illustration). Note that the forked end of the nut engages with a bracket projection to prevent the nut turning.

**11** Withdraw the rear tie-bar from its brackets, noting that it is stamped with the word TOP on the upper face of the larger end, which must be refitted accordingly.

**12** Slacken the clips and disconnect the radiator bottom hose at the radiator and main

coolant pipe, the bottom hose take-off at the expansion tank pipe, the two heater hoses at the heater matrix, and the heater outlet hose at the inlet manifold or throttle housing (see illustrations). On automatic transmission models, disconnect the two coolant hoses at the transmission oil cooler.

**13** Place absorbent rags around the fuel filter outlet banjo union bolt on the left-hand side of the filter, then slowly unscrew the bleed screw in the centre of the bolt, or the bolt itself as applicable, to relieve the fuel system pressure. When the pressure is released, remove the bolt and recover the two copper washers. Tighten the bleed screw where fitted.

**14** Release the clip and disconnect the fuel return hose from the pipe below the fuel filter.

Plug or tape over the disconnected fuel hoses and unions.

**15** Disconnect the accelerator cable at the throttle end, as described in the relevant Part of Chapter 4.

**16** Undo the brake servo vacuum hose banjo union bolt at the inlet manifold, and recover the two copper washers.

**17** On cars with single-point fuel injection, disconnect the wiring multiplug from the ignition/fuel ECU, and remove the relay from its holder behind the ECU location (see illustration).

**18** Separate the engine wiring harness from the main wiring harness by disconnecting the large round wiring multiplug located behind the battery. Additionally, on cars with single-point fuel injection, disconnect the adjacent large flat multiplug, and on cars with multi-point fuel injection, the multiplugs at the rear right-hand side of the engine compartment (see illustrations).

**19** Disconnect the two sensing leads at the battery clamps, noting their locations, and also the main positive lead to the starter motor at the battery clamp.

**20** Remove the cover from the fuse and relay box on the left-hand side of the engine compartment, then lift off the cover over the fusible links.

**21** Lift out the engine harness cable retaining clip, undo the cable retaining screw, and remove the cable from the fuse and relay box (see illustrations).



**4.12b** . . . and the heater hoses at the heater matrix (arrowed)



**4.17** Remove the relay behind the ignition/fuel ECU



**4.18a** Disconnect the large round wiring multiplug (arrowed) . . .



**4.18b** . . . and the adjacent flat multiplug

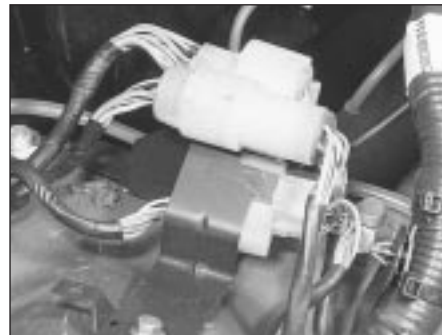

**4.18c** Disconnect the appropriate multiplugs at the rear of the engine compartment



4.21a Lift out the engine harness cable retaining clip . . .



4.21b . . . undo the cable retaining screw . . .



4.21c . . . and remove the cable from the fuse and relay box

22 Disconnect the HT and LT leads at the ignition coil.

23 Disconnect the single cable at the starter solenoid.

24 Undo the bolt and disconnect the earth lead on the side of the transmission, then slide up the rubber boot and disconnect the reversing light switch wires (see illustration).

25 On automatic transmission models, extract the spring clip and withdraw the steel and rubber washers securing the selector cable end to the transmission selector lever. Undo the outer cable retaining nut at the abutment bracket, release the inner and outer cables, and recover the inner cable spacer.

26 Disconnect the speedometer transducer cable at the wiring multiplug.

27 Check that all electrical connections between the engine and the car main wiring harness have been disconnected and moved clear. The engine wiring harness stays *in situ*, and is removed with the engine assembly.

28 Slacken the hose clips and disconnect the two power steering hoses at the fluid reservoir (see illustration). Plug the hoses and the outlets immediately to reduce fluid loss.

29 Undo the two power steering pipe support bracket bolts, and release the pipes from the brackets (see illustration).

30 On cars with a rear-mounted power steering pump, slacken the clip and disconnect the power steering fluid return hose from the pipe, then remove the pipe and hose assembly clear of the engine (see illustration).

31 Jack up the front of the car and support it on axle stands.

32 Refer to Chapter 4 if necessary, and separate the exhaust front section at the manifold or turbocharger, and at the intermediate pipe flange joints. Remove the exhaust front section from the car.

33 On manual transmission models, extract the spring clip and withdraw the clevis pin securing the clutch slave cylinder pushrod to the release arm. Undo the two slave cylinder retaining bolts and move the cylinder aside.

34 On manual transmission models, undo the bolt in the centre of the transmission steady rod. Remove the dished washer, slide off the steady rod and remove the inner flat washer. Remove the spring clip to expose the

gearchange rod-to-gearchange shaft retaining roll pin. Using a parallel pin punch, tap out the roll pin and slide the gearchange rod rearwards off the shaft.

35 Undo the eight bolts and remove the longitudinal support member from beneath the engine (see illustration).

36 On cars with a front-mounted power steering pump, undo the pipe union and remove the fluid pipe from the rear of the pump. Plug the unions to prevent fluid loss.

37 Undo the nut securing the right-hand steering knuckle balljoint to the lower suspension arm, then release the balljoint from the arm using a universal balljoint separator tool or two-legged puller.

38 Pull the steering knuckle outwards, then

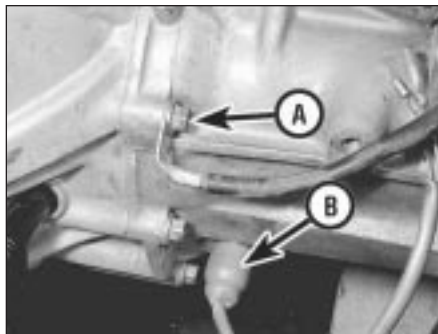

4.24 Disconnect the transmission earth lead (A) and the reversing light switch wires (B)



4.28 Disconnect the two power steering hoses at the fluid reservoir



4.29 Undo the power steering pipe support bracket bolts



4.30 Disconnect the power steering fluid return hose (arrowed)



4.35 Undo the bolts and remove the longitudinal support member (arrowed)





4.43 Remove the right-hand engine mounting

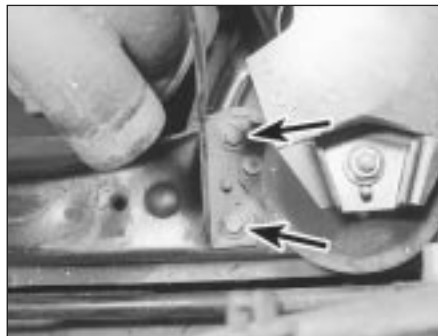

4.44 Undo the bolts (arrowed) and remove the air cleaner trunking support bracket



4.45 Undo the nut securing the front engine mounting

using a flat bar or large screwdriver, lever between the driveshaft inner constant velocity joint and the differential housing to release the joint.

39 Move the driveshaft clear, then repeat these operations on the left-hand driveshaft.

40 Attach a hoist to the engine using rope slings, or chains attached to brackets secured to the cylinder head. Adjust the ropes or chains so that the engine will hang at approximately 30° to the horizontal, with the timing belt end uppermost, when it is lifted out.

41 On automatic transmission models, undo the mounting bracket bolts and remove the engine lower tie-bar from under the front of the car, complete with mounting brackets.

42 Undo the right-hand engine mounting through-bolt, and recover the special nut. Note that the forked end of the nut plate locates over a stud on the body bracket.

43 Undo the two bolts securing the engine mounting to its mounting bracket, and remove the mounting (see illustration).

44 Undo the two bolts securing the air cleaner trunking support bracket to the front chassis member, and remove the bracket (see illustration).

45 Undo the nut securing the front engine mounting to its transmission bracket (see illustration).

46 Undo the nut securing the rear engine mounting to its transmission bracket.

47 Raise the engine slightly, then on cars with a rear-mounted power steering pump,



4.49 Removing the engine and transmission from the car

undo the power steering pipe union nut at the rear of the pump, and remove the pipe. Plug the unions to prevent loss of fluid.

48 Make a final check that everything connecting the engine and transmission to the car has been disconnected and moved well clear.

49 Carefully lift the power unit upwards, whilst moving and twisting it slightly to clear the various projections (see illustration). When the unit has been raised sufficiently, draw the hoist forwards to bring the engine unit over the front body panel, then lower it to the floor.

#### Separation - manual transmission models

50 With the engine/transmission removed from the car, undo the starter motor retaining bolts, and remove the unit from the clutch housing.

51 Undo the three bolts and remove the engine snubber bracket from the transmission adaptor plate beneath the engine sump.

52 Undo the two bolts securing the front engine mounting bracket to the transmission, and remove the bracket.

53 Undo the bolts securing the rear engine mounting bracket to the transmission, noting the location of the crankshaft sensor bracket. Move the sensor aside and remove the bracket.

54 Undo all the remaining bolts securing the transmission to the engine.

55 With the transmission well supported, release the locating dowels and draw the unit squarely away from the engine.

#### Separation - automatic transmission models

56 With the engine/transmission removed from the car, undo the starter motor retaining bolts and remove the unit from the converter housing.

57 Refer to Chapter 7, Part B and release the kickdown cable from the engine.

58 Turn the crankshaft as necessary, using a socket or spanner on the crankshaft pulley bolt, until one of the torque converter retaining bolts becomes accessible through the starter motor aperture. Undo the bolt, turn the

crankshaft and remove the remaining two bolts in the same way.

59 Undo the two bolts securing the front engine mounting bracket to the transmission, and remove the bracket.

60 Undo the bolts securing the rear engine mounting bracket to the transmission, noting the location of the crankshaft sensor bracket. Move the sensor aside and remove the bracket.

61 Undo the remaining bolts securing the transmission to the engine.

62 With the transmission well supported, release the locating dowels and draw the unit squarely away from the engine. Ensure that the torque converter stays in place on the transmission.

#### Attachment - all models

63 Attachment is the straightforward reversal of the separation sequence, but where applicable, tighten all nuts and bolts to the specified torque (Chapter 2, Part A). On manual transmission models, smear the gearbox mainshaft and release bearing face with molybdenum disulphide grease before attachment.

#### Refitting

64 Refitting is a straightforward reversal of removal, bearing in mind the following points:

- (a) Refit all the engine mounting bolts loosely, then tighten them so as not to place any under strain. Ensure that the right-hand mounting bolt is positioned centrally within the elongated slot in the body bracket.
- (b) Refill the cooling system as described in Chapter 1.
- (c) Refill the transmission as described in Chapter 1.
- (d) Fill the engine with oil as described in Chapter 1.
- (e) Refill and bleed the power steering system as described in Chapter 10.
- (f) Adjust the accelerator cable as described in the relevant Part of Chapter 4, and where applicable, the automatic transmission kickdown cable as described in Chapter 7 Part B.





5.10 Slacken the clips and disconnect the coolant hoses at the thermostat housing



5.14a Lift out the engine harness cable retaining clip . . .

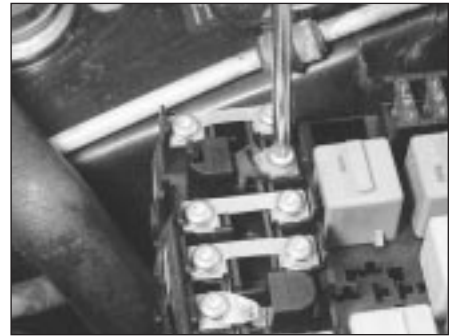

5.14b . . . undo the screw, and remove the cable from the fuse and relay box

## 5 Engine/transmission (V6 engine) - removal, separation and refitting



**Note:** The engine can be removed from the car only as a complete unit with the transmission; the two are then separated for overhaul. The engine/transmission are removed upwards and out from the top of engine compartment.

### Removal

1 Extract the retaining clips and release the support struts from the bonnet. Tie the bonnet back in the fully-open position.

2 Drain the cooling system, the engine oil, and the transmission oil or fluid as described in Chapter 1.

3 Remove the complete air cleaner and intake trunking assembly, as described in Chapter 4 Part D.

4 Remove the battery as described in Chapter 5, then undo the three bolts and remove the battery tray.

5 Refer to Chapter 3 and remove the radiator.

6 Disconnect the accelerator cable at the throttle end (Chapter 4 Part D). Release the cable from its support clips and move it clear.

7 Disconnect the HT lead at the ignition coil.

8 Undo the two through-bolts securing the engine rear tie-bar to the engine and body brackets, and recover the special forked nut. Note that the forked end of the nut engages with a bracket projection to prevent the nut turning. Withdraw the tie-bar from its brackets.

9 Undo the brake servo vacuum hose banjo union bolt at the inlet manifold, and recover the two copper washers.

10 Slacken the clips and disconnect the coolant hoses at the thermostat housing (see illustration). Disconnect the two heater hoses from their connections on the side of the engine. Disconnect any remaining coolant hoses from the engine and move them clear.

11 Undo the bolt and disconnect the earth lead on the front engine side cover.

12 Disconnect the multiplugs and release the harness from the clips on and around the dipstick tube.

13 Remove the cover from the fuse and relay box on the left-hand side of the engine compartment, then lift off the cover over the fusible links.

14 Lift out the engine harness cable retaining clip, undo the cable retaining screw, and remove the cable from the fuse and relay box (see illustrations).

15 Disconnect the two engine wiring harness wiring multiplugs located in a bracket below the battery tray.

16 Disconnect the battery lead at the starter motor.

17 Disconnect the engine earth lead on the transmission casing.

18 Check that all the vacuum hoses at the pipe cluster are numbered with corresponding numbers on their respective pipe stubs. Mark any as necessary, then disconnect all the hoses from the pipe cluster stubs.

19 Disconnect the cruise control vacuum hose and release the hose from the engine clips.

20 Check that all remaining vacuum hoses likely to impede removal of the engine have been removed.

21 Disconnect the hose at the charcoal canister (where fitted).

22 Disconnect the hose at the diverter valve (where fitted).

23 Place absorbent rags around the fuel filter outlet banjo union bolt on the left-hand side of the filter, then slowly unscrew the bleed screw in the centre of the bolt, to relieve the fuel

system pressure. When the pressure is released, remove the bolt and recover the two copper washers. Tighten the bleed screw where fitted.

24 Release the clip and disconnect the fuel return hose from the pipe below the fuel filter (see illustration). Plug or tape over the disconnected fuel hoses and unions.

25 Separate the engine wiring harness from the main wiring harness by disconnecting the three large round wiring multiplugs located at the rear right-hand side of the engine compartment (see illustration). Release the harness from the support bracket and move it clear.

26 Wipe clean the area around the pipe and hose unions on the top of the power steering pump. Place absorbent rags around the unions.

27 Undo the two bolts securing the high pressure pipe connector, lift off the connector and recover the O-ring.

28 Slacken the hose clip, then disconnect the return hose from the pump. Plug or tape over the disconnected unions to prevent dirt entry.

29 Release the hoses from the support brackets and move them clear.

30 On cars equipped with air conditioning, remove the auxiliary drivebelt as described in Chapter 1, then remove the compressor from the engine as described in Chapter 3. Don't disconnect any of the refrigerant pipes, just release the mountings. Move the compressor to one side.



5.24 Disconnect the fuel return hose from the pipe below the fuel filter



5.25 Disconnect the three wiring multiplugs at the rear of the engine compartment

**31** Undo the three expansion tank retaining bolts and move the expansion tank to one side.

**32** Jack up the front of the car and support it on axle stands. Remove the front roadwheels.

**33** Undo the bolts and remove the access panel under the right-hand wheelarch and the undertray from beneath the wheelarch.

**34** Undo the flange bolts and separate the exhaust front pipes from the manifolds. Collect the gaskets.

**35** Remove the engine oil cooler and filter head assembly as described in Part B, Section 18.

**36** Undo the retaining bolt and remove the speedometer transducer assembly from the rear of the transmission. Move the assembly clear.

**37** Undo and remove the nut from the rear engine mounting.

**38** Undo the nut securing the right-hand steering knuckle balljoint to the lower suspension arm, then release the balljoint from the arm using a universal balljoint separator tool or two-legged puller.

**39** Pull the steering knuckle outwards, then using a flat bar or large screwdriver, lever between the driveshaft and intermediate bearing assembly to release the joint.

**40** Move the driveshaft clear, then repeat these operations on the left-hand driveshaft, but release it from the differential housing.

**41** Attach a hoist using chains attached to the engine and transmission lifting eyes. Raise the hoist to just take the weight of the engine.

**42** Undo the eight bolts and remove the longitudinal support member from beneath the engine.

**43** On manual transmission models, undo the two slave cylinder retaining bolts, collect the pushrod and move the cylinder aside.

**44** On manual transmission models, undo the bolt in the centre of the transmission steady rod. Remove the dished washer, slide off the steady rod and remove the inner flat washer. Remove the spring clip to expose the gearchange rod-to-gearchange shaft retaining roll pin. Using a parallel pin punch, tap out the roll pin and slide the gearchange rod rearwards off the shaft.

**45** On automatic transmission models, refer to Chapter 7, Part B and disconnect the selector cable at the transmission end.

**46** Undo the front engine mounting retaining nut, then undo the three bolts and remove the mounting bracket from the engine.

**47** Undo the right-hand engine mounting through-bolt, and recover the special nut. Note that the forked end of the nut plate locates over a stud on the body bracket.

**48** Undo the two bolts securing the right-hand engine mounting to the engine, and remove the mounting.

**49** Check that all electrical connections between the engine and the car main wiring harness have been disconnected and moved clear. The engine wiring harness stays *in situ*, and is removed with the engine assembly.

**50** Make a final check that everything connecting the engine and transmission to the car has been disconnected and moved well clear.

**51** Support the engine on a jack with interposed block of wood positioned under the sump. Take the weight of the engine/transmission on the jack so that the hoist can be lowered slightly. Reposition the lifting chains so that the engine will adopt approximately a 30° angle to the horizontal as it is lifted out, with the timing belt end uppermost.

**52** Carefully lift the power unit upwards, whilst moving and twisting it slightly to clear the various projections (**see illustration**). When the unit has been raised sufficiently, draw the hoist forwards to bring the assembly over the front body panel, then lower it to the floor.

### Separation - manual transmission models

**53** With the engine/transmission removed from the car, undo the starter motor retaining bolts, and remove the unit from the clutch housing.

**54** Undo the bolts and remove the engine snubber bracket from the transmission adaptor plate beneath the engine sump.

**55** Undo the bolts securing the rear engine mounting bracket to the transmission, and remove the bracket.

**56** Undo all the remaining bolts securing the transmission to the engine.

**57** With the transmission well supported, release the locating dowels and draw the unit squarely away from the engine.

### Separation - automatic transmission models

**58** With the engine/transmission removed from the car, undo the starter motor retaining bolts and remove the unit from the converter housing.

**59** Refer to Chapter 7, Part B and release the kickdown cable from the engine.

**60** Turn the crankshaft as necessary, using a socket or spanner on the crankshaft pulley bolt, until one of the torque converter retaining bolts becomes accessible through the opening on the lower face of the torque

converter housing. Undo the bolt, then turn the crankshaft and remove the remaining bolts in the same way.

**61** Undo the bolts securing the rear engine mounting bracket to the transmission, and remove the bracket.

**62** Undo the remaining bolts securing the transmission to the engine.

**63** With the transmission well supported, release the locating dowels and draw the unit squarely away from the engine. Ensure that the torque converter stays in place on the transmission.

### Attachment - all models

**64** Attachment is the straightforward reversal of the separation sequence, but where applicable, tighten all nuts and bolts to the specified torque (Chapter 2, Part A). On manual transmission models, smear the gearbox mainshaft and release bearing face with molybdenum disulphide grease before attachment.

### Refitting

**65** Refitting is a straightforward reversal of removal, bearing in mind the following points:

- (a) Refit all the engine mounting bolts loosely, then tighten them so as not to place any under strain. Ensure that the right-hand mounting bolt is positioned centrally within the elongated slot in the body bracket.
- (b) Refill the cooling system as described in Chapter 1.
- (c) Refill the transmission as described in Chapter 1.
- (d) Fill the engine with oil as described in Chapter 1.
- (e) Refill and bleed the power steering system as described in Chapter 10.
- (f) Adjust the accelerator cable as described in Chapter 4, Part D and where applicable, the automatic transmission kickdown cable as described in Chapter 7 Part B.

## 6 Engine overhaul - dismantling sequence

**1** The engine dismantling and reassembly tasks are made easier if the engine is mounted on a portable engine stand which can be hired.

**2** If a stand is not available, it is possible to dismantle the engine with it supported on a strong workbench or on the floor. Be careful not to tip or drop the engine when working without a stand.

**3** If a reconditioned engine is to be fitted, all external components of the original engine must be removed in order to transfer them to the replacement unit (as they will if you are doing a complete engine rebuild). These components include the following, according to engine type.



**5.52** Removing the engine and transmission from the car

- (a) Alternator and mounting brackets.
- (b) Power steering pump and air conditioning compressor.
- (c) Distributor, HT leads and spark plugs.
- (d) Thermostat and housing.
- (e) Fuel injection system components.
- (f) Inlet and exhaust manifolds and turbocharger.
- (g) Oil filter and housing.
- (h) Engine mountings.
- (i) Flywheel/driveplate.
- (j) Water pump.
- (k) All associated pipes, hoses and brackets.

**Note:** When removing the external components from the engine, pay close attention to details that may be helpful or important during refitting. Note the fitting positions of gaskets, seals, washers, bolts and other small items.

4 If you are obtaining a short motor (which consists of the engine cylinder block, crankshaft, pistons and connecting rods all assembled), the cylinder head(s), sump, oil pump and timing belt will have to be removed also.

5 If a complete overhaul is planned, the engine can be dismantled and the internal components removed in the following order.

- (a) Inlet and exhaust manifolds.
- (b) Timing belt, tensioner and sprockets.
- (c) Cylinder head(s).
- (d) Flywheel/driveplate.
- (e) Sump.
- (f) Oil pump.

- (g) Pistons (with connecting rods).
- (h) Crankshaft.

6 Before starting the dismantling and overhaul procedures, make sure that you have all of the correct tools for the jobs to be tackled. Refer to the introductory pages at the start of this manual for further information.

## 7 Cylinder head (4-cylinder engine) - dismantling



**Note:** New and reconditioned cylinder heads are often available from the manufacturers, and from engine overhaul specialists. Due to the fact that some specialist tools are required for the dismantling and inspection procedures, and new components may not be readily available, it may be more practical and economical for the home mechanic to purchase a reconditioned head, rather than to dismantle, inspect and recondition the original head.

1 With the cylinder head on the bench, remove the camshafts and tappets, thermostat housing, inlet and exhaust manifolds, and the spark plugs, referring to the applicable Sections and Chapters of this manual as necessary.

2 To remove the valves, compress each spring in turn with a universal valve spring compressor, until the two retaining collets can be removed (see illustration).

3 Release the compressor, and lift off the spring top cup, valve spring, oil seal, valve spring seat and the valve (see illustrations).

4 It is essential that the valves are kept in their correct order, unless they are so badly worn or burnt that they are to be renewed. If they are going to be refitted, place them in their correct sequence, along with the camshaft tappets removed previously. Also keep the valve springs, cups, seats and collets in the same order.

## 8 Cylinder head and rocker gear (V6 engine) - dismantling



**Note:** Refer to the introductory note concerning reconditioned cylinder heads at the beginning of Section 7.

1 With the cylinder head on the bench, remove the camshafts and tappets, the exhaust manifold, and the spark plugs, referring to the applicable Sections and Chapters of this manual as necessary.

2 If working on the front cylinder head, undo the two bolts and remove the crank/angle sensor (where fitted) (see illustration).

3 Unscrew the two blanking plugs from the cylinder head and collect the sealing washers.

4 Screw a cylinder head bolt into the now exposed transmission end of the rocker shaft and pull the shaft out of the cylinder head.

5 As the shaft is removed, collect the rocker



7.2 Compress the valve springs with a universal valve spring compressor



7.3a Release the compressor, and lift off the spring top cup . . .



7.3b . . . valve spring . . .



7.3c . . . oil seal . . .



7.3d . . . spring seat . . .



7.3e . . . and the valve



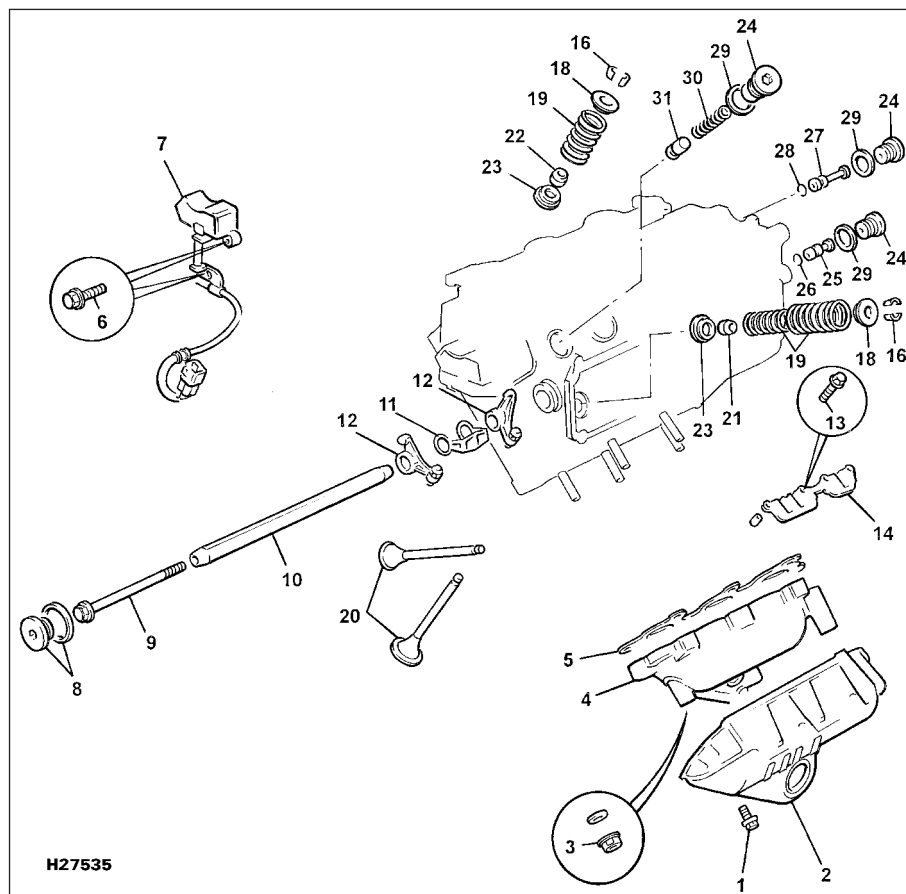

H27535

8.2 V6 engine cylinder head and rocker gear components

- |                                     |                                 |                   |
|-------------------------------------|---------------------------------|-------------------|
| 1 Exhaust manifold heat shield bolt | 9 Bolt for rocker shaft removal | 22 Oil seal       |
| 2 Exhaust manifold heat shield      | 10 Rocker shaft                 | 23 Spring seats   |
| 3 Manifold nut                      | 11 Spacer springs               | 24 Blanking plugs |
| 4 Exhaust manifold                  | 12 Rocker arm                   | 25 Oil restrictor |
| 5 Gasket                            | 13 Guide plate bolts            | 26 O-ring         |
| 6 Crank/angle sensor bolts          | 14 Guide plates                 | 27 Oil plug       |
| 7 Crank/angle sensor                | 16 Collets                      | 28 O-ring         |
| 8 Blanking plug and seal            | 18 Spring top cups              | 29 Blanking plugs |
|                                     | 19 Valve springs                | 30 Spring         |
|                                     | 20 Valves                       | 31 Relief valve   |

arm spacer springs and the rocker arms, and place them in their appropriate compartments of the marked box that has all the hydraulic tappets and slippers removed previously. Alternatively use labelled plastic bags.

6 Undo the eight bolts securing the guide plates and lift the guide plates off their locating dowels.

7 To remove the valves, compress each spring in turn with a universal valve spring compressor, until the two retaining collets can be removed.

8 Release the compressor, and lift off the spring top cup, valve spring(s), oil seal, valve spring seat and the valve.

9 It is essential that the valves are kept in their correct order, unless they are so badly worn or burnt that they are to be renewed. If they are going to be refitted, place them in

their correct sequence, along with the tappets and other parts removed previously. Also keep the valve springs, cups, seats and collets in the same order.

### 9 Cylinder head, rocker gear and valve assemblies - cleaning and inspection



**Note:** Always check first what replacement parts are available before planning any overhaul operation. A Rover dealer, or a good engine reconditioning specialist/automotive parts supplier, may be able to suggest alternatives which will enable you to overcome the lack of replacement parts.

1 Thorough cleaning of the cylinder head and valve components, followed by a detailed

inspection, will enable you to decide how much valve service work must be carried out during the engine overhaul. **Note:** If the engine has been severely overheated, it is best to assume that the cylinder head is warped, and to check carefully for signs of this.

### Cleaning

2 Scrape away all traces of old gasket material and sealing compound from the cylinder head.

3 Scrape away the carbon from the combustion chambers and ports, then wash the cylinder head thoroughly with paraffin oil or solvent.

4 Scrape off any heavy carbon deposits that may have formed on the valves, then use a power-operated wire brush to remove deposits from the valve heads and stems.

### Inspection

**Note:** Be sure to perform all the following inspection procedures before concluding that the services of a machine shop or engine overhaul specialist are required. Make a list of all items that require attention.

### Cylinder head

5 Inspect the head very carefully for cracks, evidence of coolant leakage, and damage. If cracks are found, a new cylinder head should be obtained.

6 Use a straight edge and feeler blade to check that the head gasket surface is not distorted. If it is, it may be possible to re-surface it.

7 Examine the valve seats in each of the combustion chambers. If they are severely pitted, cracked or burned, then they will need to be renewed or re-cut by an engine overhaul specialist. If they are only slightly pitted, this can be removed by grinding-in the valve heads and seats with fine valve-grinding compound, as described below.

8 If the valve guides are worn, indicated by a side-to-side motion of the valve, new guides must be fitted. Measure the diameter of the existing valve stems (see below) and the bore of the guides, then calculate the clearance, and compare the result with the specified value; if the clearance is excessive, renew the valves or guides as necessary.

9 The renewal of valve guides is best carried out by an engine overhaul specialist.

10 If the valve seats are to be re-cut, this must be done *only after* the guides have been renewed.

### Valves

11 Examine the head of each valve for pitting, burning, cracks and general wear, and check the valve stem for scoring and wear ridges. Rotate the valve, and check for any obvious indication that it is bent. Look for pits and excessive wear on the tip of each valve stem. Renew any valve that shows any such signs of wear or damage.

12 If the valve appears satisfactory at this stage, measure the valve stem diameter at





9.12 Measuring the valve stem diameter

several points, using a micrometer (see illustration). Any significant difference in the readings obtained indicates wear of the valve stem. Should any of these conditions be apparent, the valve(s) must be renewed.

13 If the valves are in satisfactory condition, they should be ground (lapped) into their respective seats, to ensure a smooth gas-tight seal. If the seat is only lightly pitted, or if it has been re-cut, fine grinding compound *only* should be used to produce the required finish. Coarse valve-grinding compound should *not* be used unless a seat is badly burned or deeply pitted; if this is the case, the cylinder head and valves should be inspected by an expert, to decide whether seat re-cutting, or even the renewal of the valve or seat insert, is required.

14 Valve grinding is carried out as follows. Place the cylinder head upside-down on a bench, with a block of wood at each end to give clearance for the valve stems.

15 Smear a trace of (the appropriate grade of) valve-grinding compound on the seat face, and press a suction grinding tool onto the valve head. With a semi-rotary action, grind the valve head to its seat, lifting the valve occasionally to redistribute the grinding compound.



*A light spring placed under the valve head will greatly ease the grinding operation.*

16 If coarse grinding compound is being used, work only until a dull, matt even surface is produced on both the valve seat and the valve, then wipe off the used compound, and repeat the process with fine compound. When a smooth unbroken ring of light grey matt finish is produced on both the valve and seat, the grinding operation is complete. *Do not* grind in the valves any further than absolutely necessary, or the seat will be prematurely sunk into the cylinder head.

17 When all the valves have been ground-in, carefully wash off *all* traces of grinding compound, using paraffin or solvent, before reassembly of the cylinder head.

### Valve components and rocker gear

18 Examine the valve springs for signs of damage and discolouration, and also measure



11.5 Removing the connecting rod cap and big-end bearing shell

their free length by comparing each of the existing springs with a new component.

19 Stand each spring on a flat surface, and check it for squareness. If any of the springs are damaged, distorted, or have lost their tension, obtain a complete set of new springs.

20 Check the spring upper seats and collets for obvious wear and cracks. Any questionable parts should be renewed, as extensive damage will occur if they fail during engine operation. Any damaged or excessively-worn parts must be renewed; the valve spring lower seat/stem oil seals must be renewed as a matter of course whenever they are disturbed.

21 Check the rocker shaft on V6 engines for straightness and for any obvious sign of scoring where the rockers contact. Similarly check the rocker bore and the fit of the rocker on the shaft. Renew any suspect parts.

### 10 Cylinder head - reassembly



1 Before reassembling the cylinder head, first ensure that it is perfectly clean and no traces of grinding paste are left in the head or on the valves and guides. Use compressed air, if available, to blow out all the oil holes and passages.

2 Commence reassembly of the cylinder head by lubricating the valve stems and guides with clean engine oil.

3 With the valves and valve seats prepared, and with the valves in their correct order, commence reassembly, starting with the first valve of No 1 cylinder as follows.

4 Place the valve spring seat in position, then fit a new oil seal over the valve guide, pushing it fully into position.

5 Lubricate the valve stem with engine oil, then insert the valve into its guide.

6 Fit the valve spring(s), and place the top cup over the spring and valve.

7 Using the compressor tool, compress the valve spring until the two collets can be slid into position. Release the compressor carefully, in order not to displace the collets.

8 Refit the remaining valves in the same way. When they are all fitted, tap the end of each



11.6 Removing the piston and connecting rod assembly

valve stem with a plastic mallet to settle the components.

### 11 Piston/connecting rod assemblies (4-cylinder engine) - removal



**Note:** Always check first what replacement parts are available before planning any overhaul operation. A Rover dealer, or a good engine reconditioning specialist/automotive parts supplier, may be able to suggest alternatives which will enable you to overcome the lack of replacement parts.

1 Remove the cylinder head, the sump, and the oil pick-up pipe as described in Part A of this Chapter.

2 Turn the crankshaft by means of the pulley bolt, until No 1 and No 4 pistons are at the bottom of their stroke.

3 Using a knife or scraper, clean the carbon ridge from the top of the cylinder bore, to facilitate removal of the piston.

4 Mark the No 1 cylinder connecting rod and cap on their sides, using a centre-punch and hammer, to indicate the cylinder the assembly is fitted to, and also the fitted relationship of the cap to the rod. **Note:** Any markings that may appear on the rod and cap are often cylinder bore size codes and not necessarily the position of the assembly in the engine. Always make your own marks to avoid confusion.

5 Undo the big-end cap nuts on No 1 connecting rod, then remove the cap, complete with the lower bearing shell (see illustration). If the cap is difficult to remove, tap it from side to side with a plastic mallet.

6 Push the piston/connecting rod upwards with the aid of the wooden handle of a hammer or similar tool, then withdraw the assembly from the top of the cylinder bore (see illustration).

7 Refit the bearing cap and shell to the connecting rod after removal.

8 Repeat paragraphs 3 to 7 for No 4 connecting rod.

9 Turn the crankshaft back through half a turn, until No 2 and No 3 pistons are at the bottom of their stroke.

10 Repeat paragraphs 3 to 7 for No 2 and No 3 connecting rods.

### 12 Piston/connecting rod assemblies (V6 engine) - removal



The procedure is the same as described in the previous Section for 4-cylinder engines, but turn the crankshaft as necessary until each pair of pistons are at the bottom of their stroke and their connecting rod caps are accessible. On later engines it will be necessary to remove the oil baffle retaining bolts and remove the baffle for access to the crankshaft components.

### 13 Crankshaft (4-cylinder engine) - removal



**Note:** *The crankshaft can be removed only after the engine has been removed from the vehicle. It is assumed that the transmission, flywheel/driveplate, adaptor plate, timing belt, cylinder head, sump, oil pump pick-up/strainer, oil pump, and piston/connecting rod assemblies, have already been removed.*

**1** Before the crankshaft is removed, check the endfloat. Mount a DTI (Dial Test Indicator, or dial gauge) with the stem in line with the crankshaft and just touching the crankshaft.  
**2** Push the crankshaft fully away from the gauge, and zero it. Next, lever the crankshaft towards the gauge as far as possible, and check the reading obtained. The distance that

the crankshaft moved is its endfloat; if it is greater than specified, check the crankshaft thrust surfaces for wear. If no wear is evident, new thrustwashers should correct the endfloat.

**3** Feeler gauges can be used if no dial gauge is available. Lever or push the crankshaft all the way towards the right-hand end of the engine. Slip feeler gauges between the crankshaft and the main bearing incorporating the thrustwashers to determine the clearance (see illustration).

**4** Withdraw the crankcase breather tube elbow from the outside of the cylinder block (see illustration).

**5** From within the crankcase, remove the crankcase breather extension tube (see illustration). To do this, move the tube from side to side to release the sealing compound, then tap it out using a dowel rod inserted through the elbow aperture.

**6** Note that the main bearing caps have their numbers cast on the face of each cap, and in addition, Nos 2, 3 and 4 have arrows indicating their fitted direction (see illustration).

**7** Undo the main bearing cap retaining bolts, one turn at a time, then when all are slack, remove the bolts.

**8** Lift away each main bearing cap and the bottom half of each bearing shell, taking care to keep the bearing shell with the right cap. If the caps are tight, tap them on their sides with a plastic mallet to release them from the locating dowels.

**9** When removing the centre main bearing cap, note the bottom semi-circular halves of the thrustwashers, one located on each side of the cap. Lay them, with the centre bearing cap, along the correct side.

**10** Lift out the crankshaft, followed by the bearing shell upper halves and the thrustwashers. Keep the bearing shells and thrustwashers with their correct caps.

### 14 Crankshaft (V6 engine) - removal



**Note:** *The crankshaft can be removed only after the engine has been removed from the vehicle. It is assumed that the transmission, flywheel/driveplate, rear oil seal carrier, timing belt, cylinder head, sump, oil pump pick-up/strainer, oil pump, and piston/connecting rod assemblies, have already been removed.*

**1** Before removing the crankshaft, check the endfloat as described in the previous Section.

**2** Where fitted, undo the bolts and remove the oil baffle from the bottom of the crankcase. Undo the eight oil gallery retaining bolts and lift the oil gallery off the main bearing caps. Collect the four O-rings from the base of the gallery (see illustration).

**3** Using a hammer and centre punch, mark the main bearing caps, 1 to 4 and make a mark to indicate their fitted direction in the crankcase.

**4** Undo the main bearing cap retaining bolts, two on the bottom and two on the side, one turn at a time; when all are slack, remove the bolts.

**5** Screw in two oil gallery bolts into each main bearing cap and pull up on the bolts to withdraw the caps from their locations (see illustration). Lift away each main bearing cap and the bottom half of each bearing shell, taking care to keep the bearing shell with the right cap. Remove the oil gallery bolts after removing the caps.

**6** Lift out the crankshaft, followed by the bearing shell upper halves and the two thrustwashers from the No 4 journal location. Keep the bearing shells and thrustwashers with their correct caps.

### 15 Cylinder block/crankcase - cleaning and inspection



**Note:** *Always check first what replacement parts are available before planning any overhaul operation. A Rover dealer, or a good engine reconditioning specialist/automotive parts supplier may be able to suggest alternatives which will enable you to overcome the lack of replacement parts.*

#### Cleaning

**1** Prior to cleaning, remove all external components and senders, and any gallery plugs or caps that may be fitted.



13.3 Checking crankshaft endfloat using feeler gauges



13.4 Withdraw the crankcase breather tube elbow



13.5 Remove the crankcase breather tube extension tube

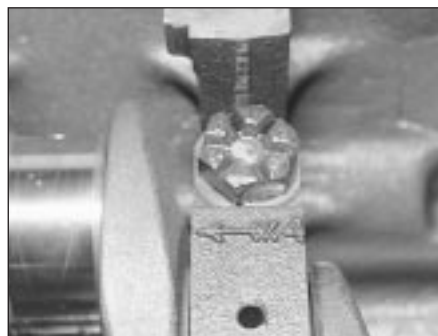

13.6 Main bearing cap identification number and direction arrow

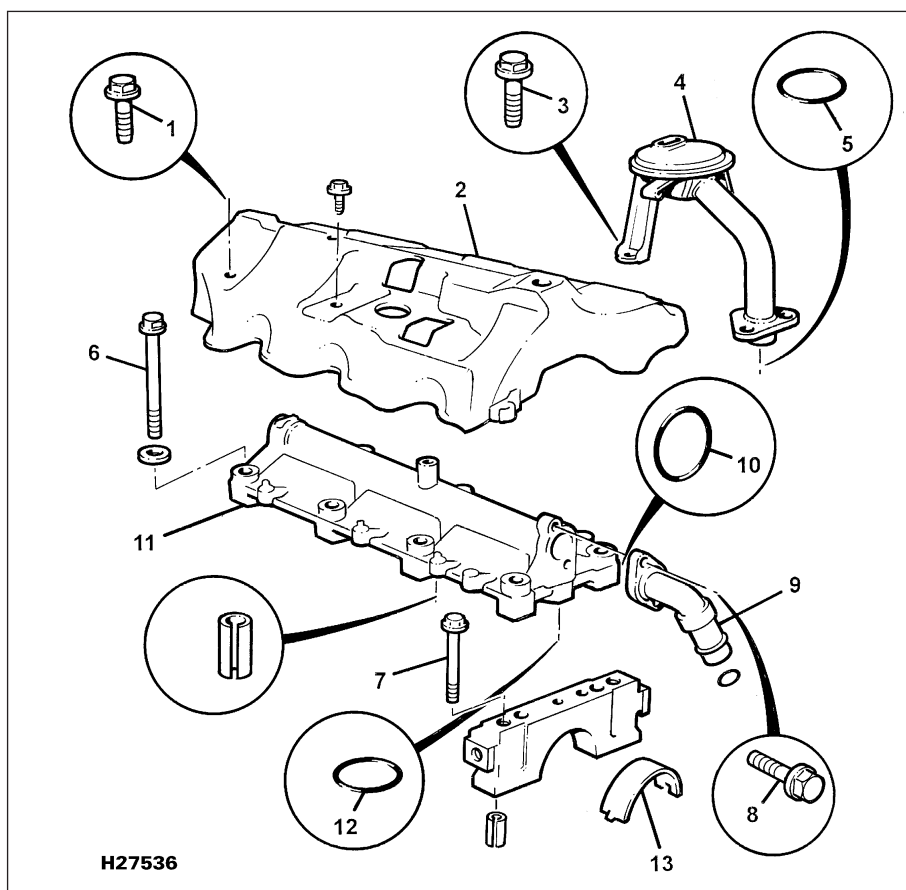

H27536

14.2 Main bearing, oil gallery and related components on V6 engines

- |                                   |                                 |                       |
|-----------------------------------|---------------------------------|-----------------------|
| 1 Oil baffle retaining bolt       | 5 O-ring                        | 10 O-ring             |
| 2 Oil baffle                      | 6 Main bearing/oil gallery bolt | 11 Oil gallery        |
| 3 Pick-up/strainer retaining bolt | 7 Main bearing/oil gallery bolt | 12 O-ring             |
| 4 Oil pump pick-up/strainer       | 8 Pipe elbow bolt               | 13 Main bearing shell |

2 If any of the castings are extremely dirty, all should be steam-cleaned.

3 After the castings are returned from steam-cleaning, clean all oil holes and oil galleries one more time. Flush all internal passages with warm water until the water runs clear, then dry thoroughly, and apply a light film of oil to all machined surfaces, to prevent rusting. If you have access to compressed air, use it to speed the drying process, and to blow out all the oil holes and galleries.



**Warning: Wear eye protection when using compressed air!**

4 If the castings are not very dirty, you can do an adequate cleaning job with hot soapy water (as hot as you can stand!) and a stiff brush. Take plenty of time, and do a thorough job. Regardless of the cleaning method used, be sure to clean all oil holes and galleries very thoroughly, and to dry all components completely; protect the machined surfaces as described above, to prevent rusting.

5 All threaded holes must be clean and dry,

to ensure accurate torque readings during reassembly; now is also a good time to clean and check the threads of all principal bolts.

6 When all inspection and repair procedures are complete (see below) and the block is ready for reassembly, refit the main bearing caps, and tighten the bolts finger-tight.

7 If the engine is not going to be reassembled right away, cover it with a large plastic bag to keep it clean; protect the machined surfaces as described above, to prevent rusting.

**Inspection**

8 Visually check the castings for cracks and corrosion. Look for stripped threads in the threaded holes. If there has been any history of internal coolant leakage, it may be worthwhile having an engine overhaul specialist check the cylinder block/crankcase for cracks with special equipment. If defects are found, have them repaired, if possible, or renew the assembly.

9 Check each cylinder bore for scuffing and scoring.

10 Noting that the cylinder bores must be

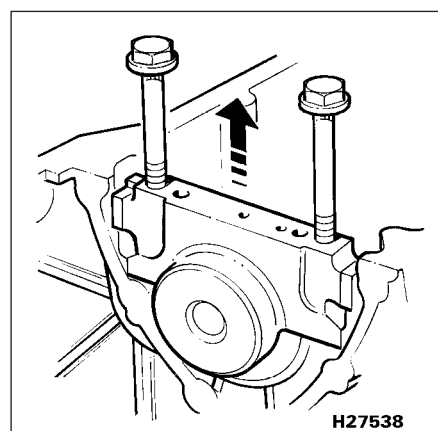

H27538

14.5 Using oil gallery bolts to withdraw the main bearing caps

measured with all the crankshaft main bearing caps bolted in place (without the crankshaft and bearing shells), to the specified torque wrench settings, measure the diameter of each cylinder at the top (just under the ridge area), centre and bottom of the cylinder bore, parallel to the crankshaft axis. Next, measure each cylinder's diameter at the same three locations across the crankshaft axis. Note the measurements obtained.

11 Measure the piston diameter at right-angles to the gudgeon pin axis, just above the bottom of the skirt; again, note the results.

12 If it is wished to obtain the piston-to-bore clearance, measure the bore and piston skirt as described above, and subtract the skirt diameter from the bore measurement. If the precision measuring tools shown are not available, the condition of the pistons and bores can be assessed, though not quite as accurately, by using feeler gauges as follows. Select a feeler gauge of thickness equal to the specified piston-to-bore clearance, and slip it into the cylinder along with the matching piston. The piston must be positioned exactly as it normally would be. The feeler gauge must be between the piston and cylinder on one of the thrust faces (at right-angles to the gudgeon pin bore). The piston should slip through the cylinder (with the feeler gauge in place) with moderate pressure; if it falls through or slides through easily, the clearance is excessive, and a new piston will be required. If the piston binds at the lower end of the cylinder, and is loose toward the top, the cylinder is tapered. If tight spots are encountered as the piston/feeler gauge is rotated in the cylinder, the cylinder is out-of-round (oval).

13 Repeat these procedures for the remaining pistons and cylinder bores.

14 Compare the results with the Specifications at the beginning of this Chapter; if any measurement is beyond the dimensions specified for that class, or if any bore measurement is significantly different from the others (indicating that the bore is tapered or oval), the piston or bore is excessively-worn.



**15** If any of the cylinder bores are badly scuffed or scored, or if they are excessively-worn, out-of-round or tapered, the usual course of action would be to have the cylinder block/crankcase rebored, and to fit new, oversized, pistons on reassembly. See a dealer or engine reconditioning specialist for advice.

**16** If the bores are in reasonably good condition and not excessively-worn, then it may only be necessary to renew the piston rings.

**17** If this is the case, the bores should be honed, to allow the new rings to bed in correctly and provide the best possible seal. Honing is an operation that will be carried out for you by an engine reconditioning specialist.

**18** After all machining operations are completed, the entire block/crankcase must be washed very thoroughly with warm soapy water to remove all traces of abrasive grit produced during the machining operations. When the cylinder block/crankcase is completely clean, rinse it thoroughly and dry it, then lightly oil all exposed machined surfaces, to prevent rusting.

**19** The cylinder block/crankcase should now be completely clean and dry, with all components checked for wear or damage, and repaired or overhauled as necessary. Refit as many ancillary components as possible, for safekeeping. If reassembly is not to start immediately, cover the block with a large plastic bag to keep it clean, and protect the machined surfaces as described above to prevent rusting.

### 16 Piston/connecting rod assemblies - inspection



**Note:** Always check first what replacement parts are available before planning any overhaul operation. A Rover dealer, or a good engine reconditioning specialist/automotive parts supplier may be able to suggest alternatives which will enable you to overcome the lack of replacement parts.

**1** Before the inspection process can be carried out, the piston/connecting rod assemblies must be cleaned, and the original piston rings removed from the pistons. The rings should have smooth, polished working surfaces, with no dull or carbon-coated sections (showing that the ring is not sealing correctly against the bore wall, so allowing combustion gases to blow by) and no traces of wear on their top and bottom surfaces. The end gaps should be clear of carbon, but not polished (indicating a too-small end gap), and all the rings (including the elements of the oil control ring) should be free to rotate in their grooves, but without excessive up-and-down movement. If the rings appear to be in good condition, they are probably fit for further use; check the end gaps (in an unworn part of the bore). If any of the rings appears to be worn or

damaged, or has an end gap significantly different from the specified value, the usual course of action is to renew all of them as a set. **Note:** While it is usual always to renew piston rings when an engine is overhauled, this of course assumes that rings are available separately - if not, it follows that great care must be taken not to break or damage any of the rings during the following procedures, and to ensure that each ring is marked on removal so that it is refitted **only** the original way up, and **only** to the same groove.

**2** Using a piston ring installation tool, carefully remove the rings from the pistons. If such a tool is not available, the rings can be removed by hand, expanding them over the top of the pistons. The use of two or three old feeler blades will be helpful in preventing the rings dropping into empty grooves. Be careful not to nick or gouge the pistons in the process, and mark or label each ring as it is removed, so that its original top surface can be identified on reassembly, and that it can be returned to its original groove.

**3** Scrape all traces of carbon from the top of the piston. A hand-held wire brush or a piece of fine emery cloth can be used, once the majority of the deposits have been scraped away. **Do not**, under any circumstances, use a wire brush mounted in a drill motor to remove deposits from the pistons - the piston material is soft, and may be eroded away by the wire brush.

**4** Use a piston ring groove-cleaning tool to remove carbon deposits from the ring grooves. If a tool isn't available, but replacement rings have been found, a piece broken off the old ring will do the job. Be very careful to remove only the carbon deposits - don't remove any metal, and do not nick or scratch the sides of the ring grooves. Protect your fingers - piston rings are sharp!

**5** Once the deposits have been removed, clean the piston/rod assemblies with solvent, and dry them with compressed air (if available). Make sure the oil return holes in the back sides of the ring grooves, and the oil hole in the lower end of each rod, are clear.

**6** If the pistons and cylinder walls aren't damaged or worn excessively, and if the cylinder block/crankcase is not rebored, new pistons won't be necessary. Normal piston wear appears as even vertical wear on the piston thrust surfaces, and slight looseness of the top ring in its groove.

**7** Carefully inspect each piston for cracks around the skirt, at the pin bosses, and at the ring lands (between the ring grooves).

**8** Look for scoring and scuffing on the thrust faces of the skirt, holes in the piston crown, and burned areas at the edge of the crown. If the skirt is scored or scuffed, the engine may have been suffering from overheating and/or abnormal combustion, which caused excessively-high operating temperatures. The cooling and lubrication systems should be checked thoroughly. A hole in the piston crown is an indication that abnormal

combustion (pre-ignition) was occurring. Burned areas at the edge of the piston crown are usually evidence of spark knock (detonation). If any of the above problems exist, the causes must be corrected, or the damage will occur again. The causes may include intake air leaks, incorrect fuel/air mixture or incorrect ignition timing.

**9** Corrosion of the piston, in the form of small pits, indicates that coolant is leaking into the combustion chamber and/or the crankcase. Again, the cause must be corrected, or the problem may persist in the rebuilt engine.

**10** Check the piston-to-rod clearance by twisting the piston and rod in opposite directions. Any noticeable play indicates excessive wear, which must be corrected. On 4-cylinder "T"-series engines and V6 engines, the piston/connecting rod assemblies should be taken to a Rover dealer or engine reconditioning specialist to have the pistons, gudgeon pins and rods checked, and new components fitted as required.

**11** On these engines, *don't* attempt to separate the pistons from the connecting rods (even if non-genuine replacements are found elsewhere). This is a task for a Rover dealer or similar engine reconditioning specialist, due to the special heating equipment, press, mandrels and supports required to do the job. If the piston/connecting rod assemblies do require this sort of work, have the connecting rods checked for bend and twist, since only such engine repair specialists will have the facilities for this purpose.

**12** On 4-cylinder "M" series engines, the gudgeon pins are retained by circlips and the pistons and connecting rods can be separated.

**13** To remove the pistons from the connecting rods, extract the two gudgeon pin retaining circlips, using a small screwdriver, then push out the gudgeon pin (see **illustration**). If the pin is tight, warm the piston in hot water, which will expand the piston slightly, enabling the gudgeon pin to be pushed out. As each piston is removed, mark it on the inside with a punch, indicating its cylinder number.

**14** Check the connecting rods for cracks and other damage. Also on 4-cylinder engines, check that the oilway in the base of the



**16.13** Using a small screwdriver to extract the gudgeon pin circlip



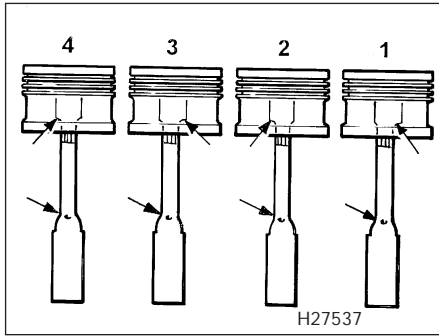

16.15a Connecting rod offset and oil squirt hole relationship on "M" series 4-cylinder engines

connecting rod is clear by probing with a piece of wire. Temporarily remove the big-end bearing caps and the old bearing shells, wipe clean the rod and cap bearing recesses, and inspect them for nicks, gouges and scratches. After checking the rods, replace the old shells, slip the caps into place, and tighten the bolts finger-tight.

15 To refit the pistons to their connecting rods on "M" series engines, start with No 1 and insert the connecting rod into the piston, so that the offset at the gudgeon pin end of the rod is towards the side of the piston marked FRONT on its top face (see illustrations). Insert the gudgeon pin, and refit the retaining circlips. Ensure that the circlips fully enter their grooves.

16 Assemble the No 3 piston and connecting rod in the same way.

17 Assemble the No 2 and No 4 pistons and connecting rods in the same way, but with the offset at the gudgeon pin end of the rod away from the side of the piston marked FRONT.

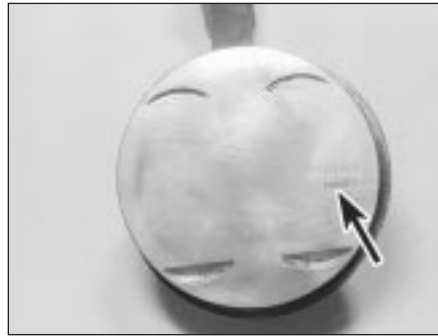

16.15b The pistons are marked FRONT on their top face (arrowed) on "M" series 4-cylinder engines



17.4 Measuring the main bearing journal diameters

5 By measuring the diameter at a number of points around each journal's circumference, you will be able to determine whether or not the journal is out-of-round. Take the measurement at each end of the journal, near the webs, to determine if the journal is tapered.

6 If the crankshaft journals are damaged, tapered, out-of-round, or worn beyond the limits specified in this Chapter, the crankshaft must be taken to an engine overhaul specialist, who will regrind it, and who can supply the necessary undersize bearing shells.

7 Check the oil seal journals at each end of the crankshaft for wear and damage. If either seal has worn an excessive groove in its journal, consult an engine overhaul specialist, who will be able to advise whether a repair is possible, or whether a new crankshaft is necessary.

parts supplier, may be able to suggest alternatives which will enable you to overcome the lack of replacement parts.

1 Even though the main and big-end bearing shells should be renewed during the engine overhaul, the old shells should be retained for close examination, as they may reveal valuable information about the condition of the engine (see illustration).

2 Bearing failure occurs because of lack of lubrication, the presence of dirt or other foreign particles, overloading the engine, and corrosion. Regardless of the cause of bearing failure, it must be corrected before the engine is reassembled, to prevent it from happening again.

3 When examining the bearing shells, remove them from the cylinder block/crankcase and main bearing caps, and from the connecting rods and the big-end bearing caps, then lay them out on a clean surface in the same general position as their location in the engine. This will enable you to match any bearing problems with the corresponding crankshaft journal. Do not touch any shell's bearing surface with your fingers while checking it, or the delicate surface may be scratched.

4 Dirt or other foreign matter gets into the engine in a variety of ways. It may be left in the engine during assembly, or it may pass

## 17 Crankshaft - inspection



**Note:** Always check first what replacement parts are available before planning any overhaul operation. A Rover dealer, or a good engine reconditioning specialist/automotive parts supplier, may be able to suggest alternatives which will enable you to overcome the lack of replacement parts.

1 Clean the crankshaft, and dry it with compressed air if available.

**Warning:** Wear eye protection when using compressed air! Be sure to clean the oil holes with a pipe cleaner or similar probe.

2 Check the main and crankpin (big-end) bearing journals for uneven wear, scoring, pitting and cracking.

3 Remove all burrs from the crankshaft oil holes with a stone, file or scraper.

4 Using a micrometer, measure the diameter of the main bearing and crankpin (big-end) journals, and compare the results with the Specifications at the beginning of this Chapter (see illustration).

## 18 Main and big-end bearings - inspection



**Note:** Always check first what replacement parts are available before planning any overhaul operation. A Rover dealer, or a good engine reconditioning specialist/automotive

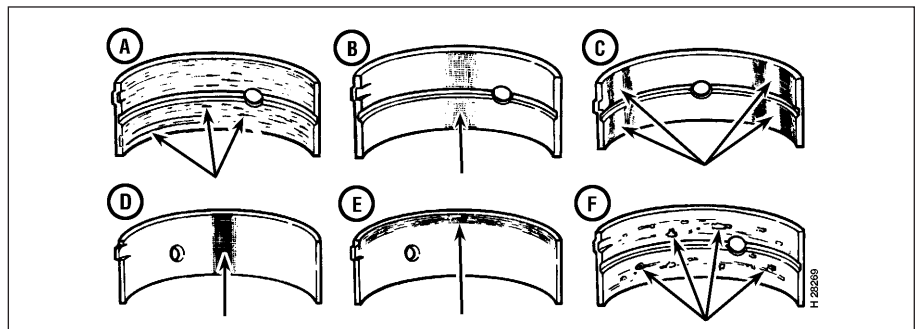

18.1 Typical bearing failures

- A Scratched by dirt; dirt embedded in bearing
- B Lack of oil; overlay wiped out
- C Improper seating; bright (polished) sections
- D Tapered journal; overlay gone from entire surface
- E Radius ride
- F Fatigue failure: craters or pockets

through filters or the crankcase ventilation system. It may get into the oil, and from there into the bearings. Metal chips from machining operations and normal engine wear are often present. Abrasives are sometimes left in engine components after reconditioning, especially when parts are not thoroughly cleaned using the proper cleaning methods. Whatever the source, these foreign objects often end up embedded in the soft bearing material, and are easily recognized. Large particles will not embed in the material, and will score or gouge the shell and journal. The best prevention for this cause of bearing failure is to clean all parts thoroughly, and to keep everything spotlessly-clean during engine assembly. Frequent and regular engine oil and filter changes are also recommended.

**5** Lack of lubrication (or lubrication breakdown) has a number of inter-related causes. Excessive heat (which thins the oil), overloading (which squeezes the oil from the bearing face) and oil leakage (from excessive bearing clearances, worn oil pump or high engine speeds) all contribute to lubrication breakdown. Blocked oil passages, which usually are the result of misaligned oil holes in a bearing shell, will also starve a bearing of oil, and destroy it. When lack of lubrication is the cause of bearing failure, the bearing material is wiped or extruded from the shell's steel backing. Temperatures may increase to the point where the steel backing turns blue from overheating.

**6** Driving habits can have a definite effect on bearing life. Full-throttle, low-speed operation (labouring the engine) puts very high loads on bearings, which tends to squeeze out the oil film. These loads cause the shells to flex, which produces fine cracks in the bearing face (fatigue failure). Eventually, the bearing material will loosen in pieces, and tear away from the steel backing. Short-distance driving leads to corrosion of bearings, because insufficient engine heat is produced to drive off condensed water and corrosive gases. These products collect in the engine oil, forming acid and sludge. As the oil is carried to the engine bearings, the acid attacks and corrodes the bearing material.

**7** Incorrect shell refitting during engine assembly will lead to bearing failure as well. Tight-fitting shells leave insufficient bearing

running clearance, and will result in oil starvation. Dirt or foreign particles trapped behind a bearing shell result in high spots on the bearing, which lead to failure. *Do not* touch any shell's bearing surface with your fingers during reassembly; there is a risk of scratching the delicate surface, or of depositing particles of dirt on it.

### 19 Engine overhaul - reassembly sequence

**1** Before reassembly begins ensure that all new parts have been obtained and that all necessary tools are available. Read through the entire procedure to familiarise yourself with the work involved, and to ensure that all items necessary for reassembly of the engine are at hand. In addition to all normal tools and materials, jointing and thread locking compound will be needed in some areas during engine reassembly. In all other cases, provided the relevant mating surfaces are clean and flat, new gaskets will be sufficient to ensure joints are oil-tight. *Do not* use any kind of silicone-based sealant on any part of the fuel system or inlet manifold, and *never* use exhaust sealants upstream of the catalytic converter.

**2** In order to save time and avoid problems, engine reassembly can be carried out in the following order (as applicable).

- (a) Crankshaft and main bearings.
- (b) Engine adaptor plate or rear oil seal carrier.
- (c) Pistons and connecting rods.
- (d) Oil pump.
- (e) Sump.
- (f) Flywheel/driveplate.
- (g) Cylinder head(s).
- (h) Camshafts and hydraulic tappets.
- (i) Timing sprockets, tensioners and belt.
- (j) Engine external components.

**3** Ensure that everything is clean prior to reassembly. As mentioned previously, dirt and metal particles can quickly destroy bearings and result in major engine damage. Use clean engine oil to lubricate during reassembly.

### 20 Piston rings - refitting



**1** Before installing new piston rings, check the end gaps. Lay out each piston set with a piston/connecting rod assembly, and keep them together as a matched set from now on.

**2** Insert the top compression ring into the first cylinder, and square it up with the cylinder walls by pushing it in with the top of the piston. The ring should be near the bottom of the cylinder, at the lower limit of ring travel.

**3** To measure the end gap, slip feeler gauges between the ends of the ring, until a gauge equal to the gap width is found (see illustration). The feeler gauge should slide

between the ring ends with a slight amount of drag. Compare the measurement to the value given in the Specifications Section of this Chapter; if the gap is larger or smaller than specified, double-check to make sure you have the correct rings before proceeding. If you are assessing the condition of used rings, have the cylinder bores checked and measured by a Rover dealer or similar engine reconditioning specialist, so that you can be sure of exactly which component is worn, and seek advice as to the best course of action to take.

**4** If the end gap is still too small, it must be opened up by careful filing of the ring ends using a fine file. If it is too large, this is not as serious, unless the specified limit is exceeded, in which case very careful checking is required of the dimensions of all components, as well as of the new parts.

**5** Repeat the procedure for each ring that will be installed in the first cylinder, and for each ring in the remaining cylinders. Remember to keep rings, pistons and cylinders matched up.

**6** Refit the piston rings as follows. Where the original rings are being refitted, use the marks or notes made on removal, to ensure that each ring is refitted to its original groove and the same way up. New rings generally have their top surfaces identified by markings (often an indication of size, such as "STD", or the word "TOP") - the rings must be fitted with such markings uppermost. **Note:** *Always follow the instructions printed on the ring package or box - different manufacturers may require different approaches. Do not mix up the top and second compression rings, as they usually have different cross-sections.*

**7** The oil control ring (lowest one on the piston) is usually installed first. It is composed of three separate elements. Slip the spacer/expander into the groove. If an anti-rotation tang is used, make sure it is inserted into the drilled hole in the ring groove. Next, install the lower side rail. Don't use a piston ring installation tool on the oil ring side rails, as they may be damaged. Instead, place one end of the side rail into the groove between the spacer/expander and the ring land, hold it firmly in place, and slide a finger around the piston while pushing the rail into the groove. Next, install the upper side rail in the same manner.

**8** After the three oil ring components have been installed, check that both the upper and lower side rails can be turned smoothly in the ring groove.

**9** The second compression (middle) ring is installed next, followed by the top compression ring - ensure their marks are uppermost, and be careful not to confuse them. Don't expand either ring any more than necessary to slide it over the top of the piston.

**10** When all the rings are in place set the ring gaps as follows:

*4-cylinder "M" series engines - set the compression ring gaps at 90° to each other, and away from the thrust side of*

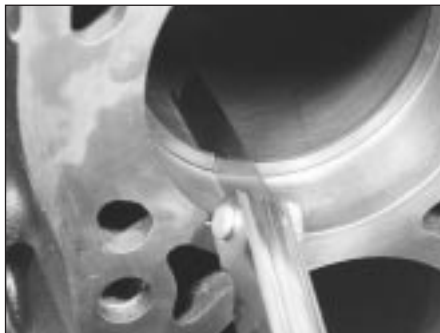

20.3 Measuring piston ring end gap



21.4 Fitting the main bearing shell upper halves

the piston. Position the gaps of the two oil control rails and the expander at 90° to each other.

4-cylinder "T" series engines - set the compression ring gaps at 120° to each other and away from the inlet valve cut-out side of the piston. Position the gaps of the two oil control rails at 120° to each other and the gap of the expander at 120° to the rail gaps. On turbocharged engines, position the oil control rail gap and spring gap at 30° on opposite sides of the gudgeon pin axis.

V6 engines - set the compression ring gaps at 90° to each other and the oil control expander gap at 90° to the top ring gap. Position the oil control rail gaps at 15° either side of the expander gap.

## 21 Crankshaft - refitting and main bearing running clearance check



1 It is assumed at this point that the cylinder block/crankcase and crankshaft have been cleaned, inspected and repaired or reconditioned as necessary. Position the engine upside-down.

2 Remove the main bearing cap bolts, and lift out the caps. Lay the caps out in the proper order, to ensure correct installation.

3 If they're still in place, remove the old bearing shells from the block and the main bearing caps. Wipe the bearing recesses of the block and caps with a clean, lint-free cloth. They must be kept spotlessly-clean!

### Main bearing running clearance check

4 Wipe clean the main bearing shell seats in the crankcase and clean the backs of the bearing shells. Insert the respective upper shells (dry) into position in the crankcase and the lower shells into their respective caps. On the V6 engines, the shells with the oil grooves are fitted to the crankcase, and the plain shells are fitted to the caps. Where the old main bearings are being refitted, ensure that they are located in their original positions. Make sure the tab on each bearing shell fits



21.5 Fitting the crankshaft thrustwashers

into the notch in the block or cap (see illustration).

**Caution: Don't hammer the shells into place, and don't nick or gouge the bearing faces. No lubrication should be used at this time.**

5 Place the crankshaft thrustwashers into position in the crankcase so that their oil grooves are facing outwards (away from the central web) (see illustration).

6 Clean the bearing surfaces of the shells in the block, and the crankshaft main bearing journals with a clean, lint-free cloth. Check or clean the oil holes in the crankshaft, as any dirt here can go only one way - straight through the new bearings.

7 Once you're certain the crankshaft is clean, carefully lay it in position in the main bearings. Trim several pieces of the appropriate-size Plastigage (they must be slightly shorter than the width of the main bearings), and place one piece on each crankshaft main bearing journal, parallel with the crankshaft centre-line (see illustration).

8 Clean the bearing surfaces of the cap shells, and install the caps in their respective positions (don't mix them up) with the arrows pointing to the timing belt end of the engine or positioned according to the marks made during removal. Don't disturb the Plastigage.

9 Working on one cap at a time, from the centre main bearing outwards (and ensuring that each cap is tightened down squarely and evenly onto the block), tighten the main



21.11 Measuring the width of the deformed Plastigage using the scale on the card provided



21.7 Plastigage in place on a crankshaft main bearing journal

bearing cap bolts to the specified torque wrench setting (Chapter 2, Part A). Don't rotate the crankshaft at any time during this operation!

10 Remove the bolts, and carefully lift off the main bearing caps (on V6 engines, use the oil gallery bolts as before). Keep them in order. Don't disturb the Plastigage or rotate the crankshaft.

11 Compare the width of the crushed Plastigage on each journal with the scale printed on the Plastigage envelope to obtain the main bearing running clearance (see illustration). Check the Specifications to make sure that the clearance is correct.

12 If the clearance is not as specified, seek the advice of a Rover dealer or similar engine reconditioning specialist - if the crankshaft journals are in good condition, it may be possible simply to renew the shells to achieve the correct clearance. If this is not possible, the crankshaft must be reground by a specialist who can supply the necessary undersized shells. First though, make sure that no dirt or oil was between the bearing shells and the caps or block when the clearance was measured. If the Plastigage is noticeably wider at one end than the other, the journal may be tapered.

13 Carefully scrape all traces of the Plastigage material off the main bearing journals and the bearing surfaces. Be very careful not to scratch the bearing - use your fingernail or the edge of a credit card.



21.14 Thoroughly lubricate the crankshaft journals



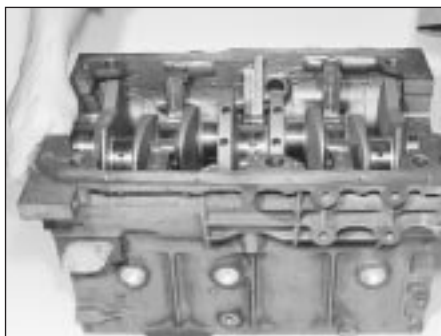

21.16a Crankshaft installation

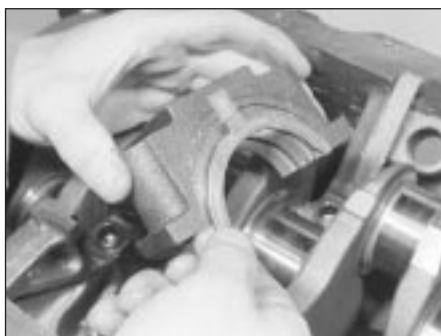

21.16b Fitting the crankshaft thrustwasher lower halves to the centre bearing cap on 4-cylinder engines

### Final refitting

**14** Carefully lift the crankshaft out of the engine. Clean the bearing surfaces of the shells in the block, then apply a thin, uniform layer of clean molybdenum disulphide-based grease, engine assembly lubricant, or clean engine oil to each surface (see illustration). Coat the thrustwasher surfaces as well.

**15** Lubricate the crankshaft oil seal journals with molybdenum disulphide-based grease, engine assembly lubricant, or clean engine oil.

**16** Make sure the crankshaft journals are clean, then lay the crankshaft back in place in the block (see illustration). Clean the bearing surfaces of the shells in the caps, then lubricate them. Install the caps in their respective positions, with the arrows pointing to the timing belt end of the engine or the previously made marks positioned correctly. When fitting the centre main bearing cap on 4-cylinder engines, ensure that the thrustwashers, generously lubricated, are fitted with their oil grooves facing outwards, and the locating tab of each is engaged with the slot in the main bearing cap (see illustration). Apply RTV sealant into the vertical grooves on the edges of Nos 1 and 5 main bearing caps, then fit these caps to their locations.

**17** On 4-cylinder engines, working on one cap at a time, from the centre main bearing outwards (and ensuring that each cap is tightened down squarely and evenly onto the block), tighten the main bearing cap bolts to

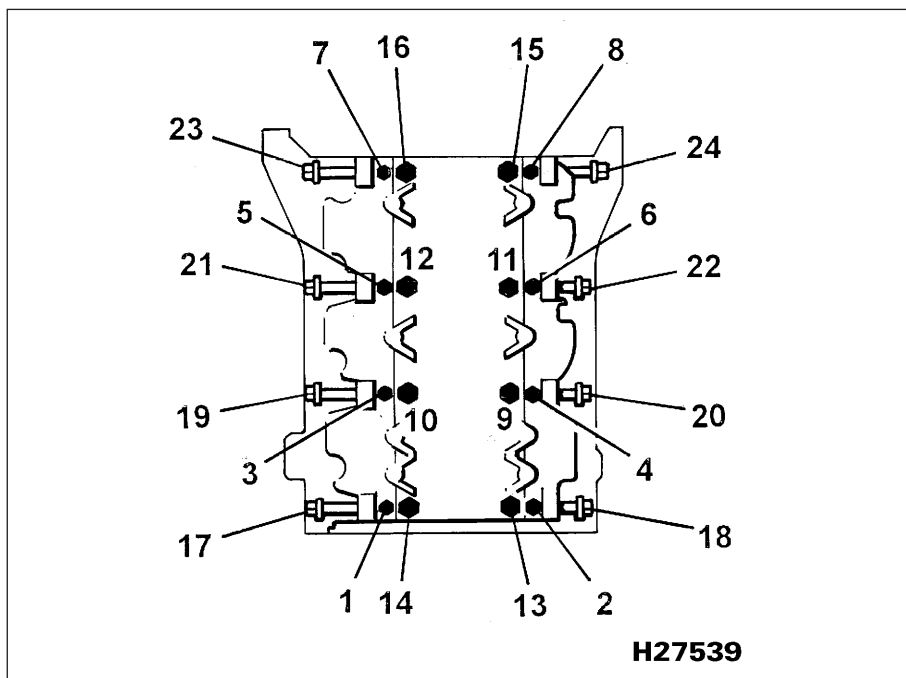

21.18 Main bearing cap retaining bolt tightening sequence on V6 engines

the specified torque wrench setting (Chapter 2, Part A).

**18** On V6 engines, tighten the bolts to the specified torque (Chapter 2, Part A) in the sequence shown (see illustration).

**19** Rotate the crankshaft a number of times by hand, to check for any obvious binding.

**20** Check the crankshaft endfloat. It should be correct if the crankshaft thrust faces aren't worn or damaged.

**21** On 4-cylinder engines, apply sealer to the crankcase breather tube extension, then fit the tube to its location. Apply sealant to the breather tube elbow, and fit the elbow, ensuring that it is tapped down until the shoulder contacts the crankcase.

**22** On V6 engines, refit the oil gallery, use new O-ring seals and secure with the bolts tightened to the specified torque (Chapter 2, Part A).

**23** Refit the engine oil seal carrier, or adaptor plate and install a new seal (see Part A or B of this Chapter according to engine type).

### 22 Piston/connecting rod assemblies - refitting and big-end bearing running clearance check



**1** Before refitting the piston/connecting rod assemblies, the cylinder bores must be perfectly clean, the top edge of each cylinder must be chamfered, and the crankshaft must be in place.

**2** Remove the big-end bearing cap from No 1 cylinder connecting rod (refer to the marks noted or made on removal). Remove the original bearing shells, and wipe the bearing

recesses of the connecting rod and cap with a clean, lint-free cloth. They must be kept spotlessly-clean!

### Big-end bearing running clearance check

**3** Clean the back of the new upper bearing shell, fit it to the connecting rod, then fit the other shell of the bearing set to the big-end bearing cap. Make sure the tab on each shell fits into the notch in the rod or cap recess.

**Caution: Don't hammer the shells into place, and don't nick or gouge the bearing face. Don't lubricate the bearing at this time.**

**4** It's critically important that all mating surfaces of the bearing components are perfectly clean and oil-free when they're assembled.

**5** Position the piston ring gaps as described in Section 16, lubricate the piston and rings with clean engine oil, and attach a piston ring compressor to the piston. Leave the skirt protruding about a quarter-inch, to guide the piston into the cylinder bore. The rings must be compressed until they're flush with the piston.

**6** Rotate the crankshaft until No 1 crankpin (big-end) journal is at Bottom Dead Centre, and apply a coat of engine oil to the cylinder walls.

**7** Arrange the No 1 piston/connecting rod assembly so that the word FRONT or the arrow on the piston crown points to the timing belt end of the engine. Gently insert the assembly into the No 1 cylinder bore, and rest the bottom edge of the ring compressor on the engine block.



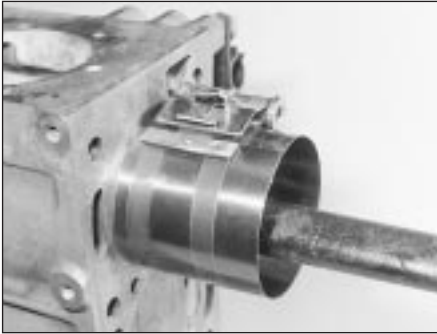

**22.9 Refitting the piston and connecting rod assemblies, with the aid of a ring compressor**

**8** Tap the top edge of the ring compressor to make sure it's contacting the block around its entire circumference.

**9** Gently tap on the top of the piston with the end of a wooden hammer handle (see illustration), while guiding the connecting rod's big-end onto the crankpin. The piston rings may try to pop out of the ring compressor just before entering the cylinder bore, so keep some pressure on the ring compressor. Work slowly, and if any resistance is felt as the piston enters the cylinder, stop immediately. Find out what's binding, and fix it before proceeding. *Do not*, for any reason, force the piston into the cylinder - you might break a ring and/or the piston.

**10** To check the big-end bearing running clearance, cut a piece of the appropriate-size Plastigage slightly shorter than the width of the connecting rod bearing, and lay it in place on the No 1 crankpin (big-end) journal, parallel with the crankshaft centre-line.

**11** Clean the connecting rod-to-cap mating surfaces, and refit the big-end bearing cap. Tighten the cap bolts to the specified torque (Chapter 2, Part A). Don't rotate the crankshaft at any time during this operation!

**12** Unscrew the bolts and detach the cap, being very careful not to disturb the Plastigage.

**13** Compare the width of the crushed Plastigage to the scale printed on the Plastigage envelope, to obtain the running clearance. Compare it to the Specifications, to make sure the clearance is correct.

**14** If the clearance is not as specified, seek the advice of a Rover dealer or similar engine reconditioning specialist - if the crankshaft journals are in good condition, it may be possible simply to renew the shells to achieve the correct clearance. If this is not possible, the crankshaft must be reground by a specialist, who can also supply the necessary undersized shells. First though, make sure that no dirt or oil was trapped between the bearing shells and the connecting rod or cap when the clearance was measured. Also, recheck the crankpin diameter. If the Plastigage was wider at one end than the other, the crankpin journal may be tapered.

**15** Carefully scrape all traces of the Plastigage material off the journal and the bearing surface. Be very careful not to scratch the bearing - use your fingernail or the edge of a credit card.

### **Final piston/connecting rod refitting**

**16** Make sure the bearing surfaces are perfectly clean, then apply a uniform layer of clean molybdenum disulphide-based grease, engine assembly lubricant, or clean engine oil, to both of them. You'll have to push the piston into the cylinder to expose the bearing surface of the shell in the connecting rod.

**17** Slide the connecting rod back into place on the crankpin (big-end) journal, refit the big-end bearing cap, and then tighten the bolts as described above.

**18** Repeat the entire procedure for the remaining piston/connecting rod assemblies.

**19** The important points to remember are:

- (a) *Keep the backs of the bearing shells and the recesses of the connecting rods and caps perfectly clean when assembling them.*
- (b) *Make sure you have the correct piston/rod assembly for each cylinder.*
- (c) *The arrow on the piston crown or the word FRONT must face the timing belt end of the engine.*
- (d) *Lubricate the cylinder bores with clean engine oil.*
- (e) *Lubricate the bearing surfaces when refitting the big-end bearing caps after the running clearance has been checked.*

**20** After all the piston/connecting rod

assemblies have been properly installed, rotate the crankshaft a number of times by hand, to check for any obvious binding.

**21** Continue with the engine reassembly in the sequence given in Section 19.

## **23 Engine - initial start-up after overhaul**



**1** With the engine refitted in the vehicle, double-check the engine oil and coolant levels. Make a final check that everything has been reconnected, and that there are no tools or rags left in the engine compartment.

**2** Refit the spark plugs, and connect all the spark plug (HT) leads (Chapter 1). Switch on the ignition and listen for the fuel pump; it will run for a little longer than usual, due to the lack of pressure in the system.

**3** Start the engine, noting that this also may take a little longer than usual, due to the fuel system components being empty.

**4** While the engine is idling, check for fuel, coolant and oil leaks. Don't be alarmed if there are some odd smells and smoke from parts getting hot and burning off oil deposits. If the hydraulic tappets have been disturbed, some valve gear noise may be heard at first; this should disappear as the oil circulates fully around the engine, and normal pressure is restored in the tappets.

**5** Keep the engine idling until hot water is felt circulating through the top hose, check that it idles reasonably smoothly and at the usual speed, then switch it off.

**6** After a few minutes, recheck the oil and coolant levels, and top-up as necessary (Chapter 1).

**7** If they were tightened as described, there is no need to re-tighten the cylinder head bolts once the engine has first run after reassembly.

**8** If new components such as pistons, rings or crankshaft bearings have been fitted, the engine must be run-in for the first 500 miles (800 km). Do not operate the engine at full-throttle, or allow it to labour in any gear during this period. It is recommended that the oil and filter be changed at the end of this period.





# Chapter 3

## Cooling, heating and air conditioning systems

### Contents

Air conditioning system - general information and precautions . . . .	13	Cooling system servicing (draining, flushing and refilling) . . See Chapter 1	
Air conditioning system check . . . . . See Chapter 1		Electric cooling fan assembly - testing, removal and refitting . . . . .	5
Air conditioning system components - removal and refitting . . . . .	14	General information . . . . .	1
Antifreeze - general information . . . . .	2	Heater/air conditioning controls - removal and refitting . . . . .	12
Auxiliary drivebelts check and renewal . . . . . See Chapter 1		Heater/ventilation components - removal and refitting . . . . .	11
Coolant level check . . . . . See Chapter 1		Radiator (4-cylinder engines) - removal, inspection and refitting . . . . .	7
Cooling system electrical switches and sensors - removal and refitting . . . . .	6	Radiator (V6 engines) - removal, inspection and refitting . . . . .	8
Cooling system checks (coolant leaks, hose condition) . See Chapter 1		Thermostat - removal, testing and refitting . . . . .	4
Cooling system hoses - disconnection and renewal . . . . .	3	Water pump (4-cylinder engines) - removal and refitting . . . . .	9
		Water pump (V6 engines) - removal and refitting . . . . .	10

### Degrees of difficulty

<b>Easy</b> , suitable for novice with little experience 	<b>Fairly easy</b> , suitable for beginner with some experience 	<b>Fairly difficult</b> , suitable for competent DIY mechanic 	<b>Difficult</b> , suitable for experienced DIY mechanic 	<b>Very difficult</b> , suitable for expert DIY or professional 
---	--	--	---	--

### Specifications

#### Coolant

Mixture type . . . . .	See Chapter 1
Cooling system capacity . . . . .	See Chapter 1

#### Expansion tank cap

System pressure . . . . .	1.0 bar
---------------------------	---------

#### Thermostat

4-cylinder engines:	
Starts-to-open temperature . . . . .	76° to 80°C
Fully-open temperature . . . . .	88°C
V6 engines:	
Fully-open temperature . . . . .	78°C

#### Air conditioning system

Refrigerant . . . . .	R12 or R134a
-----------------------	--------------

#### Torque wrench settings

	Nm	lbf ft
Water outlet elbow to thermostat housing . . . . .	25	18
Thermostat housing to cylinder head . . . . .	25	18
Water pump:		
to cylinder block ("M" series engines) . . . . .	25	18
housing cover bolts ("T" series engines) . . . . .	7	5
to engine plate (V6 engines):		
M6x22 . . . . .	22	16
M6x25 . . . . .	12	9
Engine mounting bracket bolts . . . . .	25	18
Timing belt tensioner plate . . . . .	12	9
Intercooler to radiator bolts . . . . .	15	11
Air conditioning condenser pipe unions:		
M17 bolts . . . . .	17	13
M22 bolts . . . . .	12	9
Air conditioning condenser pipe union bolts (From VIN 152206) . . . . .	10	7
Air conditioning compressor pipe unions . . . . .	25	18
Air conditioning compressor mounting bolts . . . . .	25	18
Air conditioning compressor pipe bracket bolt . . . . .	10	7
Air conditioning receiver/dryer pipe unions . . . . .	12	9
Air conditioning evaporator pipe unions . . . . .	25	18

1 General information

**Engine cooling system**

The cooling system is of the pressurized, pump-assisted thermosyphon type. The system consists of the radiator, water pump, thermostat, electric cooling fan, expansion tank and associated hoses (see illustrations). On "M" series 4-cylinder engines, and V6 engines, the impeller type water pump is mounted on the right-hand end of the engine, and is driven by the timing belt. On "T" series 4-cylinder engines, the water pump is mounted behind, and driven by, the power steering pump, which itself is driven by the auxiliary drive belt.

The system functions as follows. Cold coolant in the bottom of the radiator left-hand tank passes, via hoses and pipes, to the water pump, where it is pumped around the cylinder block and head passages. After cooling the cylinder bores, combustion surfaces and valve seats, the coolant reaches the underside of the thermostat, which is initially closed, and is diverted through a bypass hose to the heater matrix. On 4-cylinder engines, after passing through the heater, the coolant travels through the water jacket of the inlet manifold or throttle housing, and to the turbocharger, or to the automatic transmission fluid cooler where applicable, before returning to the water pump inlet hose. On V6 engines, after passing through the heater, the coolant circulates through the engine oil cooler, fuel system fast idle valve, idle control valve, throttle body and inlet manifold and to the automatic transmission fluid cooler, where applicable, before returning to the water pump.

When the engine is cold, the thermostat remains closed, and the coolant only circulates as described. When the coolant reaches a predetermined temperature, the thermostat opens, and the coolant passes through the top hose to the radiator right-hand tank. As the coolant circulates around the radiator, it is cooled by the inrush of air when the car is in forward motion. Airflow is supplemented by the action of the electric cooling fan(s) when necessary. Upon reaching the left-hand side of the radiator, the coolant is now cooled and the cycle is repeated.

When the engine is at normal operating temperature, the coolant expands, and some of it is displaced into the expansion tank. This coolant collects in the tank, and is returned to the radiator when the system cools.

The electric cooling fan mounted on the radiator is controlled by a thermostatic switch, located in the radiator right-hand side tank. At a predetermined coolant temperature, the switch contacts close, thus actuating the fan. On models equipped with air conditioning, additional fans are fitted for cooling of the air conditioning system condenser.

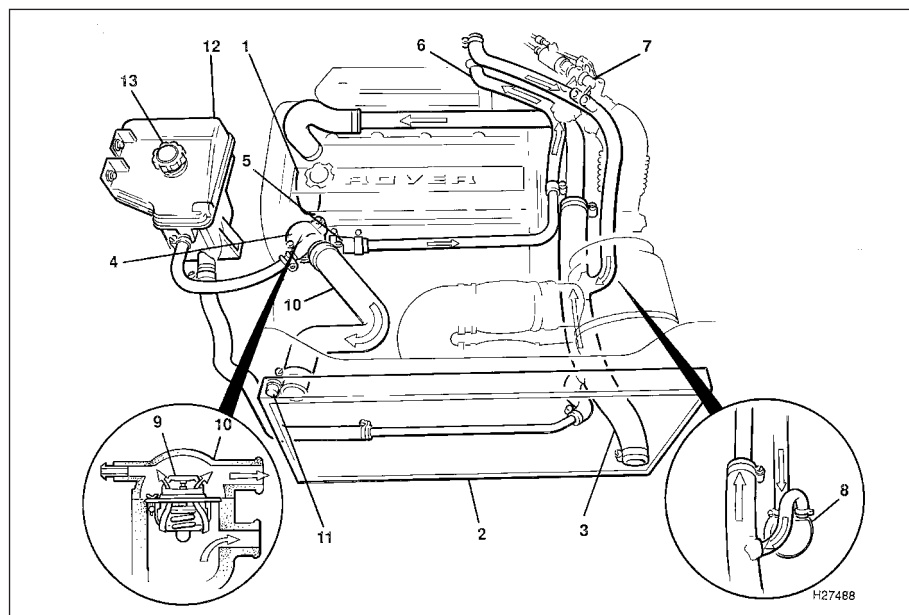

1.1a Cooling system layout and flow diagram - 4-cylinder engines

- |   |                                       |                                    |
|---|---------------------------------------|------------------------------------|
| Dark arrows indicate hot coolant flow   | 4 Thermostat housing                  | 10 Coolant flow through top hose   |
| Light arrows indicate cold coolant flow | 5 Bypass (heater) hose                | 11 Cooling fan thermostatic switch |
| 1 Water pump                            | 6 Heater hose                         | 12 Expansion tank                  |
| 2 Radiator                              | 7 Throttle housing                    | 13 Pressure cap                    |
| 3 Bottom hose                           | 8 Automatic transmission fluid cooler |                                    |
|   | 9 Thermostat open                     |                                    |

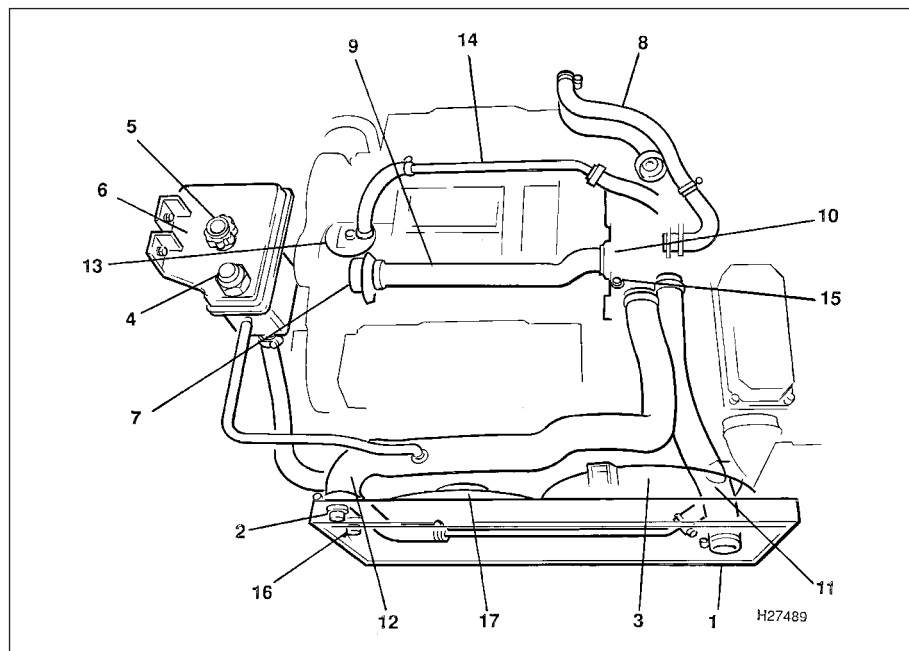

1.1b Cooling system layout - V6 engines

- |                                   |                         |   |
|-----------------------------------|-------------------------|---|
| 1 Radiator                        | 7 Water pump            | 14 Oil cooler return pipe                             |
| 2 Cooling fan thermostatic switch | 8 Heater hoses          | 15 Bleed screw  |
| 3 Radiator cooling fan            | 9 Water pump inlet pipe | 16 Air conditioning condenser fan thermostatic switch |
| 4 Coolant low level switch        | 10 Thermostat housing   | 17 Air conditioning condenser fan                     |
| 5 Pressure cap                    | 11 Bottom hose          |   |
| 6 Expansion tank                  | 12 Top hose             |   |
|                                   | 13 Oil cooler           |   |



**Warning:** *DO NOT attempt to remove the expansion tank filler cap, or to disturb any part of the cooling system, while it or the engine is hot, as there is a very great risk of scalding. If the expansion tank filler cap must be removed before the engine and radiator have fully cooled down (even though this is not recommended) the pressure in the cooling system must first be released. Cover the cap with a thick layer of cloth, to avoid scalding, and slowly unscrew the filler cap until a hissing sound can be heard. When the hissing has stopped, showing that pressure is released, slowly unscrew the filler cap further until it can be removed; if more hissing sounds are heard, wait until they have stopped before unscrewing the cap completely. At all times, keep well away from the filler opening.*



**Warning:** *If the engine is hot, the electric cooling fan(s) may start rotating even if the engine is not running, so be careful to keep hands, hair and loose clothing well clear when working in the engine compartment.*

### Heating system

The heating system consists of a blower fan and heater matrix (radiator) located in the heater unit, with hoses connecting the heater matrix to the engine cooling system. Hot engine coolant is circulated through the heater matrix. When the heater temperature control on the fascia is operated, a flap door opens to expose the heater box to the passenger compartment. When the blower control is operated, the blower fan forces air through the unit according to the setting selected.

### Air conditioning system

See Section 14.

## 2 Antifreeze - general information



**Warning:** *Do not allow antifreeze to come in contact with your skin, or with the painted surfaces of the vehicle. Rinse off spills immediately with plenty of water. Antifreeze is highly toxic if ingested. Never leave antifreeze lying around in an open container, or in puddles on the floor; children and pets are attracted by its sweet smell, and may drink it. Check with local authorities about disposing of used antifreeze - many have collection centres which will see that antifreeze is disposed of safely.*

The cooling system should be filled with a water/ethylene glycol-based antifreeze solution, of a strength which will prevent freezing down to -25°C, or lower if the local

climate requires it. Antifreeze also provides protection against corrosion, and increases the coolant boiling point.

The cooling system should be maintained according to the schedule described in Chapter 1. If antifreeze is used that is not to Rover's specification, old or contaminated coolant mixtures are likely to cause damage, and encourage the formation of corrosion and scale in the system. Use distilled water with the antifreeze, if available - if not, be sure to use only soft water. Clean rainwater is suitable.

Before adding antifreeze, check all hoses and hose connections, because antifreeze tends to leak through very small openings. Engines don't normally consume coolant, so if the level goes down, find the cause and correct it.

The exact mixture of antifreeze-to-water which you should use depends on the relative weather conditions. On all V6 engines, and 4-cylinder engines equipped with air conditioning, the mixture should contain approximately 50% antifreeze. On 4-cylinder engines without air conditioning, approximately a 33% antifreeze mixture is recommended. Antifreeze concentrations greater than 55% for V6 engines or 60% for 4-cylinder engines are not recommended as the efficiency of the cooling system may be impaired. Consult the mixture ratio chart on the antifreeze container before adding coolant. Hydrometers are available at most automotive accessory shops to test the coolant. Use antifreeze which meets the vehicle manufacturer's specifications.

## 3 Cooling system hoses - disconnection and renewal

**Note:** *Refer to the warnings given in Section 1 of this Chapter before starting work.*

1 If the checks described in Chapter 1 reveal a faulty hose, it must be renewed as follows.

2 First drain the cooling system (see Chapter 1); if the antifreeze is not due for renewal, the drained coolant may be re-used, if it is collected in a clean container.

3 To disconnect any hose, use a pair of pliers to release the spring clamps (or a screwdriver to slacken screw-type clamps), then move them along the hose clear of the union. Carefully work the hose off its stubs. The hoses can be removed with relative ease when new - on an older car, they may have stuck.

4 If a hose proves stubborn, try to release it by rotating it on its unions before attempting to work it off. Gently prise the end of the hose with a blunt instrument (such as a flat-bladed screwdriver), but do not apply too much force, and take care not to damage the pipe stubs or hoses. Note in particular that the

radiator hose unions are fragile; do not use excessive force when attempting to remove the hoses.



**If all else fails, cut the coolant hose with a sharp knife, then slit it so that it can be peeled off in two pieces. While expensive, this is preferable to buying a new radiator. Check first, however, that a new hose is readily available.**

5 When refitting a hose, first slide the clamps onto the hose, then work the hose onto its unions. If the hose is stiff, use soap (or washing-up liquid) as a lubricant, or soften it by soaking it in boiling water, but take care to prevent scalding.

6 Work each hose end fully onto its union, then check that the hose is settled correctly and is properly routed. Slide each clip along the hose until it is behind the union flared end, before tightening it securely.

7 Refill the system with coolant (see Chapter 1).

8 Check carefully for leaks as soon as possible after disturbing any part of the cooling system.

## 4 Thermostat - removal, testing and refitting



**Note:** *Refer to the warnings given in Section 1 of this Chapter before starting work.*

### 4-cylinder engines

#### Removal

1 Partially drain the cooling system (approximately 2.5 litres), using the procedure described in Chapter 1.

2 Slacken the clips and detach the radiator top hose and expansion tank hose from the water outlet elbow on the thermostat housing (see illustration).

3 Undo the two bolts and remove the water



4.2 Detach the radiator top hose and expansion tank hose from the water outlet elbow



### 3•4 Cooling, heating and air conditioning systems



4.3a Undo the two retaining bolts . . .



4.3b . . . and remove the water outlet elbow



4.4 Withdraw the thermostat from the housing

outlet elbow (see illustrations). Remove the gasket.

4 Withdraw the thermostat from its seat in the housing (see illustration).

5 To remove the housing, disconnect the coolant temperature sensor wiring multiplug(s). A single sensor is fitted to early engines; two are fitted to later engines.

6 Slacken the retaining clips, and disconnect the heater pipe connecting hose from the side of the housing.

7 Undo the two bolts, and remove the thermostat housing and gasket from the cylinder head (see illustration).

#### Testing

8 Before assuming the thermostat is to blame for a cooling system problem, check the coolant level, where applicable the auxiliary drivebelt tension and condition (see Chapter 1) and temperature gauge operation.

9 If the engine seems to be taking a long time to warm up (based on heater output or temperature gauge operation), the thermostat is probably stuck open. Renew the thermostat.

10 If the engine runs hot, use your hand to check the temperature of the radiator top hose. If the hose isn't hot, but the engine is, the thermostat is probably stuck closed, preventing the coolant inside the engine from escaping to the radiator - renew the thermostat.

**Caution: Don't drive the vehicle without a thermostat. The lack of a thermostat will slow warm-up time. The engine**



4.7 Removing the thermostat housing

**management system's ECU will then stay in warm-up mode for longer than necessary, causing emissions and fuel economy to suffer.**

11 If the radiator top hose is hot, it means that the coolant is flowing and the thermostat is open. Consult the "Fault diagnosis" section at the front of this manual to assist in tracing possible cooling system faults.

12 If the thermostat remains in the open position at room temperature, it is faulty, and must be renewed as a matter of course.

13 To test it fully, suspend the (closed) thermostat on a length of string in a container of cold water, with a thermometer beside it; ensure that neither touches the side or bottom of the container.

14 Heat the water, and check the temperature at which the thermostat begins to open, or is fully open. Compare this value with the figures given in the Specifications, then remove the thermostat and allow it to cool down; check that it closes fully.

15 If the thermostat does not open and close as described, if it sticks in either position, or if it does not open at the specified temperature, it must be renewed.

#### Refitting

16 Refitting is a reversal of removal, bearing in mind the following points:

- Position the unit with its support legs across the heater outlet pipe.
- Clean away all traces of old gasket from the mating faces, and use a new gasket, lightly smeared with jointing compound.
- Tighten the water outlet elbow retaining bolts to the specified torque.
- Top up the cooling system with reference to Chapter 1.

#### V6 engines

##### Removal

17 Refer to Chapter 4, Part D, and remove the air cleaner components as necessary for access to the thermostat housing.

18 Partially drain the cooling system (approximately 2.5 litres), using the procedure described in Chapter 1.

19 Undo the bolt securing the hose support bracket to the thermostat housing and move the hoses aside (see illustration).

20 Slacken the clip and detach the radiator hose from the thermostat housing.

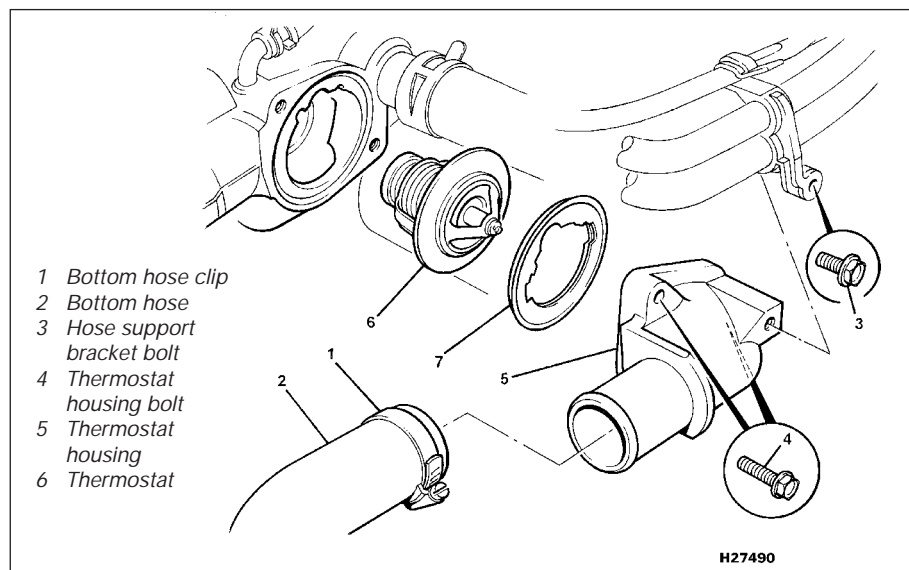

4.19 Thermostat and housing components on V6 engines

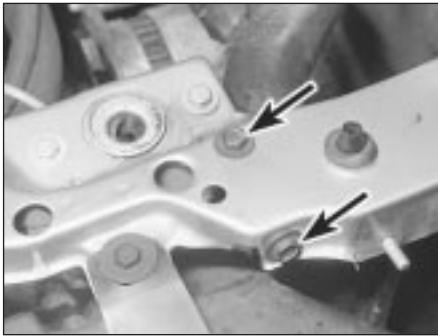

5.6 Centre platform retaining bolts - right-hand side (arrowed)

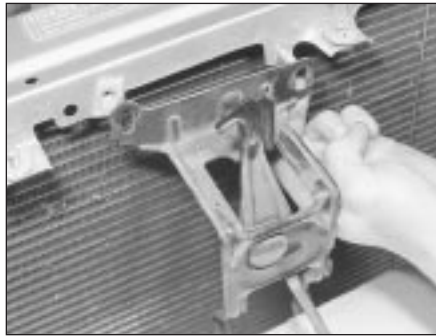

5.7 Remove the bonnet safety catch from the centre platform



5.8 Cut off the cable ties securing the bonnet release cable

21 Undo the three bolts and remove the thermostat housing and gasket.

22 Withdraw the thermostat from its seat in the housing.

### Testing

23 Refer to the procedures described above for 4-cylinder engines.

### Refitting

24 Refitting is a reversal of removal. Ensure that the housing mating surfaces are clean and use a new gasket.

## 5 Electric cooling fan assembly - testing, removal and refitting



**Note:** Refer to the warnings given in Section 1 of this Chapter before starting work.

**Note:** On cars equipped with air conditioning, a second cooling fan for the condenser is mounted alongside the main cooling fan for the radiator. The following procedures are applicable to both types of installation.

### Testing

1 The cooling fans are controlled by complex circuitry and their operation is dependant on a number of factors. Single or twin fans may be fitted, with variable speed operation. Numerous sensors used in conjunction with the engine management system and, where

fitted, the air conditioning system determine their operating temperature and at what speed they will run.

2 If it is suspected that the cooling fan(s) are not operating when high engine temperature would normally require them to do so, check the relevant fuses and relays (see Chapter 12) and ensure that all wiring connections are clean and soundly made.

3 Further testing can really only be carried out successfully using Rover test equipment and should therefore be entrusted to a dealer.

### Removal

4 On pre-1992 model year vehicles, remove the radiator grille as described in Chapter 11, Section 19.

5 On turbocharged and V6 engines, remove the engine undertray.

6 Undo the two bolts each side securing the centre platform to the body side members (see illustration).

7 Undo the nut and retaining bolt securing the bonnet safety catch to the centre platform (see illustration).

8 Lift the centre platform upwards, turn it over, and cut off the cable ties securing the bonnet release cable to the platform underside (see illustration). Remove the platform from the car.

9 Disconnect the cooling fan multiplug at the wiring connector (see illustration).

10 Undo the three retaining nuts (four on turbocharged engines), then carefully lift out

the cooling fan assembly (see illustrations). Note that the cooling fan, motor and cowl are a balanced assembly, and should not be dismantled. Should renewal be necessary, all three components are supplied as an assembled unit.

### Refitting

11 Refitting is a reversal of removal.

## 6 Cooling system electrical switches and sensors - removal and refitting



**Note:** Refer to the warnings given in Section 1 of this Chapter before starting work.

### Cooling fan thermostatic switch

**Note:** On cars equipped with air conditioning, a second thermostatic switch for the condenser fan is mounted in the radiator side tank, below the main thermostatic switch for the radiator cooling fan. The following procedures are applicable to both types of installation.

### Removal

1 Partially drain the cooling system (approximately 2.5 litres), as described in Chapter 1

2 Disconnect the two wires, remove the switch retaining ring, which is a bayonet



5.9 Disconnect the cooling fan multiplug at the wiring connector



5.10a Cooling fan upper retaining nut (arrowed)



5.10b Removing the cooling fan assembly

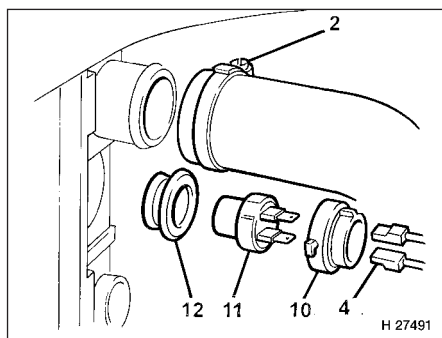

**6.2 Cooling fan thermostatic switch components**

- |                           |                          |
|---------------------------|--------------------------|
| 2 Top hose retaining clip | 10 Switch retaining ring |
| 4 Wiring connectors       | 11 Switch                |
|                           | 12 Seal                  |

fitting, and withdraw the switch and seal from the radiator (see illustration).

**Refitting**

3 Refitting is a reversal of removal, but renew the seal if the old one has deteriorated. Top up the cooling system as described in Chapter 1.

**Coolant temperature sensors**

**Removal**

4 The coolant temperature sensors contain an element, the resistance of which alters



**6.7a Disconnecting the coolant temperature sensor multiplug on the 4-cylinder engine**

according to coolant temperature. The units control the operation of the temperature gauge, and are also used by the fuel and ignition system control units to determine engine temperature. Depending on the engine management system fitted, either a single sensor performs both functions, or a separate sensor is used for each.

5 On 4-cylinder engines either a single sensor, or two sensors are located on the thermostat housing. On V6 engines a single sensor is located in a coolant passage on top of the engine, just below the distributor.

6 Partially drain the cooling system (approximately 2.5 litres) as described in Chapter 1.

7 Disconnect the wiring multiplug, then unscrew the relevant sensor from its location (see illustrations).

**Refitting**

8 Refitting is a reversal of removal, but refill the cooling system as described in Chapter 1.

**7 Radiator (4-cylinder engines) - removal, inspection and refitting**



**Note:** Refer to the warnings given in Section 1 of this Chapter before starting work.

**Radiator - normally aspirated engines**

**Removal**

1 Drain the cooling system as described in Chapter 1. Leave the bottom radiator hose disconnected.

2 Slacken the retaining clip and disconnect the radiator top hose.

3 Disconnect the cooling fan motor multiplug(s) at the wiring connector(s).

4 Disconnect the wires at the thermostatic switch(s) just below the top hose outlet.

5 On pre-1992 model year vehicles, remove the radiator grille as described in Chapter 11, Section 19.

6 Undo the two bolts each side securing the centre platform to the body side members (see illustration 5.6).

7 Undo the nut and retaining bolt securing the bonnet safety catch to the centre platform (see illustration 5.7).

8 Lift the centre platform upwards, turn it over, and cut off the cable ties securing the bonnet release cable to the platform underside. Remove the platform from the car.

9 Lift the radiator upwards, and carefully remove it from the car.

10 With the radiator removed, it can be inspected for leaks and damage. If it needs repair, have a radiator specialist or dealer service department perform the work, as special techniques are required. Clear the matrix of flies and small leaves with a soft brush, or by hosing.

11 Reverse-flush the radiator, as described in Chapter 1. Renew the top and bottom hoses and clips if they are damaged or have deteriorated.

**Refitting**

12 Refitting the radiator is a reversal of removal, but ensure that the lower mounting lugs engage in the rubber grommets, and the centre platform grommets locate over the radiator upper lugs (see illustrations). Re-secure the bonnet release cable to the centre platform, using new cable ties. On completion, fill the cooling system as described in Chapter 1.



**7.12a Ensure that the radiator lower lugs (arrowed) engage with the rubber grommets . . .**

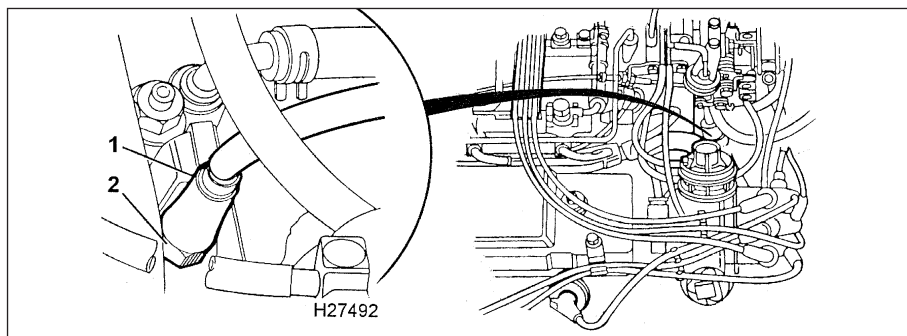

**6.7b Coolant temperature sensor location on V6 engines**

- |                    |                      |
|--------------------|----------------------|
| 1 Wiring multiplug | 2 Temperature sensor |
|--------------------|----------------------|



**7.12b . . . and the centre platform grommets (arrowed) locate over the radiator upper lugs**



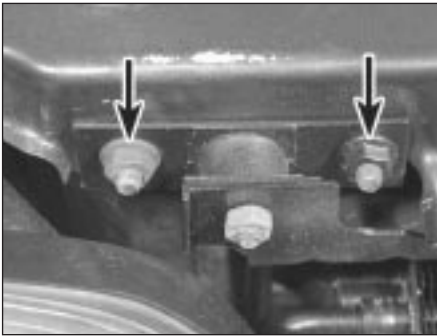

8.4 Condenser-to-centre platform retaining nuts (arrowed) on the right-hand side



8.6 Undo the screw and release the hose support strap from the fan cowl



9.3 Removing the lower backplate from the engine (early metal version shown, later plastic version similar)

## Radiator and intercooler - turbocharged engines

### Removal

- 13 Remove the right-hand headlight lens unit as described in Chapter 12, Section 7.
- 14 Remove the air cleaner components, as necessary for access to the radiator, as described in the relevant Part of Chapter 4.
- 15 Drain the cooling system as described in Chapter 1. Leave the bottom radiator hose disconnected.
- 16 Slacken the retaining clip and disconnect the radiator top hose.
- 17 Disconnect the cooling fan motor multiplug(s) at the wiring connector(s).
- 18 Disconnect the wires at the thermostatic switch(s) just below the top hose outlet.
- 19 On pre-1992 model year vehicles, remove the radiator grille as described in Chapter 11, Section 19.
- 20 Undo the two bolts each side securing the centre platform to the body side members.
- 21 Undo the nut and retaining bolt securing the bonnet safety catch to the centre platform.
- 22 Lift the centre platform upwards, turn it over, and cut off the cable ties securing the bonnet release cable to the platform underside. Remove the platform from the car.
- 23 Slacken the hose clip and disconnect the coolant outlet hose at the turbocharger.
- 24 Slacken the retaining clip and remove the air intake hose from the turbocharger.
- 25 Slacken the two clips and remove the air intake and outlet hoses from the intercooler.
- 26 Lift the radiator and intercooler upwards, and carefully remove the assembly from the car.
- 27 If required, remove the upper and lower mounting bolts and nuts and separate the intercooler from the radiator.
- 28 With the radiator removed, it can be inspected for leaks and damage. If it needs repair, have a radiator specialist or dealer service department perform the work, as special techniques are required. Clear the matrix of flies and small leaves with a soft brush, or by hosing.
- 29 Reverse-flush the radiator, as described in Chapter 1. Renew the top and bottom hoses and clips if they are damaged or have deteriorated.

### Refitting

- 30 Refitting the radiator and intercooler is a reversal of removal, but ensure that the lower mounting lugs engage in the rubber grommets, and the centre platform grommets locate over the radiator upper lugs. Re-secure the bonnet release cable to the centre platform, using new cable ties. On completion, fill the cooling system as described in Chapter 1.

## 8 Radiator (V6 engines) - removal, inspection and refitting



**Note:** Refer to the warnings given in Section 1 of this Chapter before starting work.

### Removal

- 1 Drain the cooling system as described in Chapter 1. Leave the bottom radiator hose disconnected.
- 2 On pre-1992 model year vehicles, remove the radiator grille as described in Chapter 11, Section 19.
- 3 Undo the two bolts each side securing the centre platform to the body side members (see illustration 5.6).
- 4 On vehicles with air conditioning, undo the two nuts securing the condenser to the front of the centre platform (see illustration).
- 5 Undo the nut and retaining bolt securing the bonnet safety catch to the centre platform (see illustration 5.7).
- 6 On vehicles equipped with air conditioning, cut off the cable ties or undo the screws and release the support straps, securing the various hoses to the centre platform and to the fan cowl (see illustration).
- 7 Lift the centre platform upwards, turn it over, and cut off the cable ties securing the bonnet release cable to the platform underside. Remove the platform from the car.
- 8 Slacken the retaining clip and disconnect the radiator top hose.
- 9 Disconnect the cooling fan motor multiplug(s) at the wiring connector(s).
- 10 Disconnect the wires at the thermostatic switch(s) just below the top hose outlet.

- 11 Where applicable, unscrew the union nuts and disconnect the automatic transmission oil cooler pipes from the radiator. Cover the disconnected pipes and fit blanking plugs to the radiator ports.

- 12 Lift the radiator upwards, and carefully remove it from the car.

- 13 With the radiator removed, it can be inspected for leaks and damage. If it needs repair, have a radiator specialist or dealer service department perform the work, as special techniques are required. Clear the matrix of flies and small leaves with a soft brush, or by hosing.

- 14 Reverse-flush the radiator, as described in Chapter 1. Renew the top and bottom hoses and clips if they are damaged or have deteriorated.

### Refitting

- 15 Refitting the radiator is a reversal of removal, but ensure that the lower mounting lugs engage in the rubber grommets, and the centre platform grommets locate over the radiator upper lugs (see illustrations 7.12a and 7.12b). Re-secure the bonnet release cable and hoses to the centre platform, using new cable ties. On completion, fill the cooling system as described in Chapter 1. On models with automatic transmission, top up the transmission fluid as described in Chapter 1.

## 9 Water pump (4-cylinder engines) - removal and refitting



**Note:** Refer to the warnings given in Section 1 of this Chapter before starting work.

### "M" Series engines

#### Removal

- 1 Drain the cooling system as described in Chapter 1.
- 2 Remove the timing belt as described in Chapter 2, Part A.
- 3 Undo the three remaining bolts securing the lower backplate to the engine, noting that on some engines, one bolt also retains a breather hose clip, and one retains an oil pipe clip. Remove the lower backplate (see illustration).



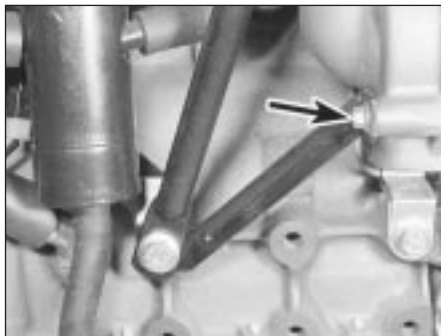

9.6 Undo the bolt (arrowed) securing the support strut to the housing

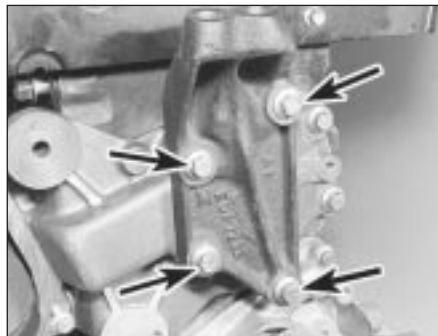

9.7 Undo the four bolts securing the right-hand engine mounting bracket to the water pump

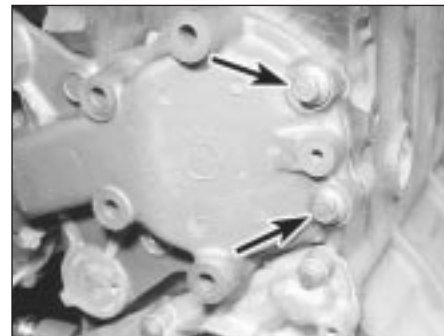

9.8 Undo the remaining two bolts securing the water pump to the cylinder block

4 If not already done, undo the centre retaining bolt and remove the timing belt tensioner.

5 Slacken the clip and detach the water inlet hose from the rear of the pump.

6 Undo the bolt securing the support strut to the rear of the pump housing (see illustration).

7 Undo the four bolts securing the right-hand engine mounting bracket to the water pump, then remove the bracket (see illustration).

8 Undo the remaining two bolts securing the water pump to the cylinder block (see illustration).

9 Have a container handy to catch any remaining coolant, then withdraw the pump from the block. If necessary, carefully tap the pump body with a soft-faced mallet to free it.

10 With the pump removed, scrape away all traces of RTV sealant from the pump and cylinder block mating faces, ensuring that both are completely clean and dry.

11 If the pump is to be renewed, undo the three bolts or Torx type socket-headed screws, as applicable, and remove the timing belt tensioner mounting plate so that it can be transferred to the new pump. Note, however, that it will be necessary to obtain new bolts or screws, prior to refitting. These are of the micro-encapsulated type incorporating locking compound in their threads; consequently, they can only be used once.

**Refitting**

12 If removed, locate the timing belt tensioner mounting plate in position, and fit

the three bolts or screws tightened to the specified torque.

Do not attempt to retighten any of the screws or bolts after the locking compound has set (approximately two minutes), otherwise the locking properties will be destroyed, and the screws may loosen in service.

13 Apply a thin, continuous bead of RTV sealant to the cylinder block mating face, and locate the water pump in position (see illustration).

14 Apply thread sealer to the two pump retaining bolts, and fit them finger-tight at this stage.

15 Apply thread sealer to the four engine mounting bracket-to-pump bolts, fit the bracket and tighten the bolts to the specified torque. Now tighten the two pump bolts fitted previously.

16 Refit the bolt securing the support strut to the rear of the pump housing.

17 Reconnect the inlet water hose.

18 Refit the lower backplate to the engine, and secure with the three bolts.

19 Refer to Chapter 2, Part A, and refit the timing belt.

20 Refit the auxiliary drivebelt and refill the cooling system as described in Chapter 1.

**"T" Series engines**

**Removal**

21 Drain the cooling system as described in Chapter 1.

22 Slacken the clip and detach the water inlet hose from the rear of the pump cover (see illustration).

23 Undo the five bolts and remove the pump cover from the housing.

24 Withdraw the pump assembly from the housing and, where fitted, collect and discard the three sealing rings. The sealing rings are used on factory assembly, but Loctite sealer is used instead, when the pump is refitted or renewed in service.

25 Thoroughly clean the sealing ring grooves, removing all traces of any old sealant (if the pump has been removed previously).

**Refitting**

26 Refitting is a reversal of removal, but apply Loctite 405 to the sealing ring grooves, and tighten the retaining bolts to the specified torque. Refill the cooling system as described in Chapter 1 on completion.



9.13 Apply RTV sealant to the cylinder block mating face

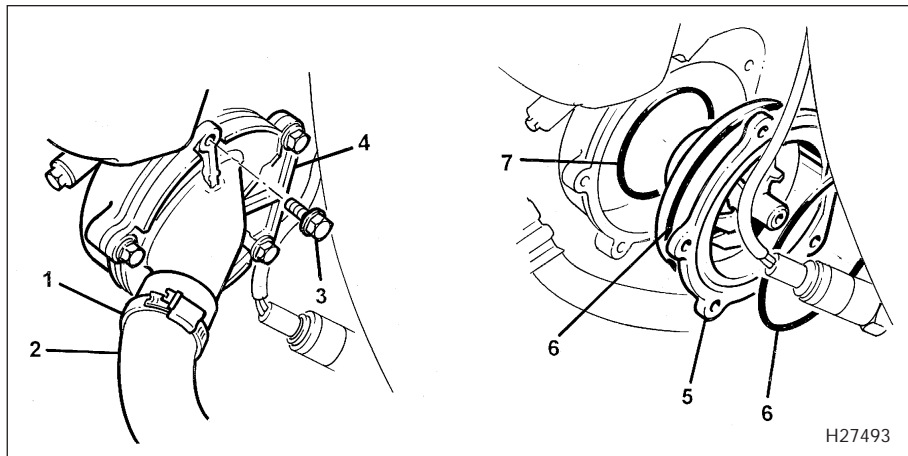

9.22 Water pump components on the "T" series engine

- |                              |                    |                      |
|------------------------------|--------------------|----------------------|
| 1 Hose clip                  | 4 Water pump cover | 6 Sealing rings      |
| 2 Water inlet hose           | 5 Water pump       | 7 Inner sealing ring |
| 3 Pump cover retaining bolts |                    |                      |

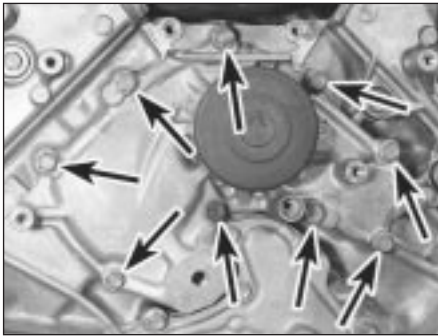

10.3 Water pump retaining bolts (arrowed) on V6 engines

### 10 Water pump (V6 engines) - removal and refitting



**Note:** Due to the layout of the V6 engine and the limited space available in the engine compartment, access to most components is extremely limited and may present unforeseen difficulties. Read through all the relevant procedures and familiarize yourself with what's involved before proceeding.

**Note:** Refer to the warnings given in Section 1 of this Chapter before starting work.

#### Removal

- 1 Drain the cooling system as described in Chapter 1.
- 2 Remove the timing belt and timing belt tensioner as described in Chapter 2, Part B.
- 3 Undo the nine bolts securing the water pump to the engine front plate, noting that two are of a different length than the rest (see illustration).
- 4 Withdraw the water pump and recover the large sealing O-ring.
- 5 Thoroughly clean the mating faces, locating dowels and O-ring recesses.

#### Refitting

- 6 Refitting is a reversal of removal, but use a new sealing O-ring, and tighten the retaining bolts to the specified torque. Refit the timing belt and tensioner as described in Chapter 2,



11.6 Blower motor wiring multiplug

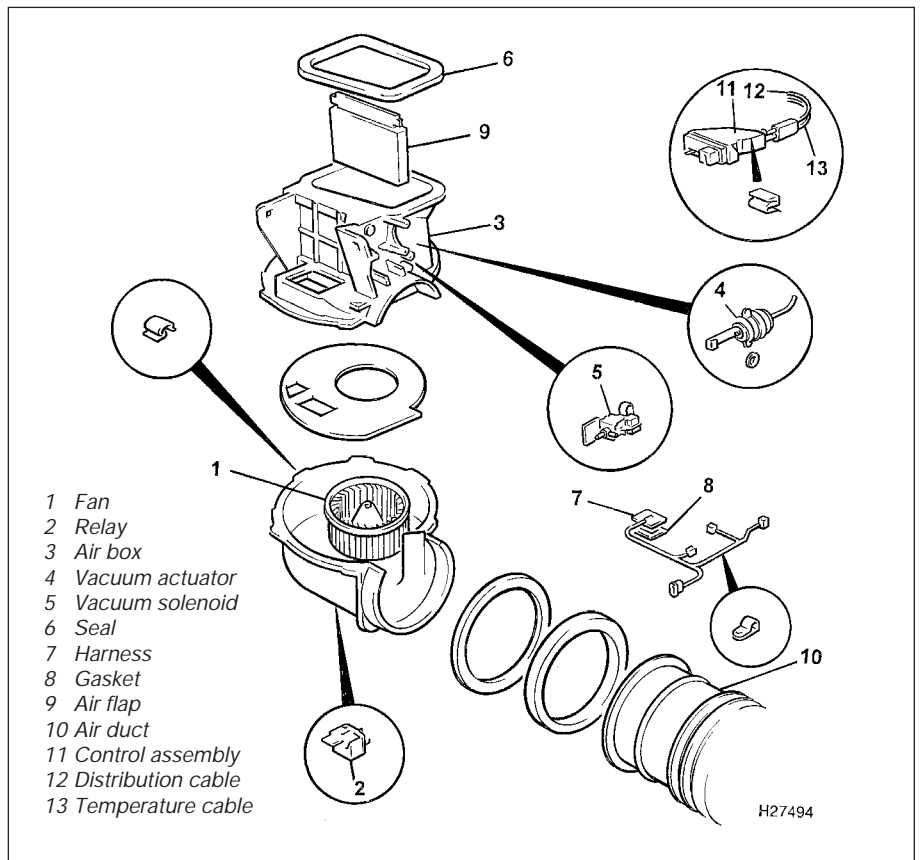

11.4 Exploded view of the heater blower motor housing assembly

Part B, and refill the cooling system as described in Chapter 1.

### 11 Heater/ventilation components - removal and refitting



#### Heater blower motor and housing assembly

##### Removal

- 1 Disconnect the battery negative (earth) lead (refer to Chapter 5, Section 1).
- 2 Remove the trim panel under the fascia on the passenger's side.

3 Open the glovebox, undo the two screws securing the glovebox bar, and remove the glovebox.

- 4 Disconnect the air duct from the side of the unit, and recover the seals (see illustration).
- 5 Release the screw cap and undo the fascia retaining bolt at the extreme end, adjacent to the door aperture.
- 6 Disconnect the blower motor wiring multiplug (see illustration).
- 7 Disconnect the vacuum hose at the solenoid (see illustration).
- 8 Undo the two upper bolts and one lower nut securing the heater housing assembly in position, and remove the unit from under the fascia (see illustrations).



11.7 Solenoid vacuum hose (arrowed)

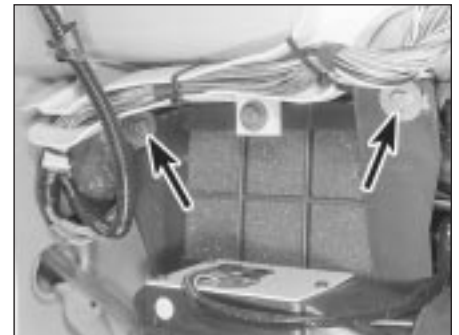

11.8a Undo the two upper bolts (arrowed) . . .

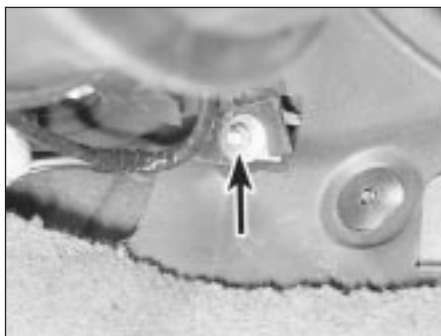

11.8b ... and lower nut (arrowed)

**Refitting**

9 Refitting is a reversal of removal.

**Heater blower motor**

**Removal**

10 Remove the blower motor and housing assembly from the car as described previously.

11 Extract the clips securing the two halves of the housing assembly, and lift off the upper half.

12 Remove the separator plate.

13 Undo the nut and remove the fan from the motor.

14 Disconnect the cooling hose and wiring multiplug from the side of the motor.

15 Undo the motor retaining nuts, withdraw the motor and collect the gasket.

**Refitting**

16 Refitting is a reversal of removal.

**Heater matrix**

**Removal**

17 Remove the fascia as described in Chapter 11.

18 Drain the cooling system as described in Chapter 1.

19 From within the engine compartment, disconnect the heater hoses at the matrix pipe stubs.

20 Remove the duct between the heater blower motor assembly and the matrix housing. Collect the two seals.

21 Extract the retaining stud from the driver's side footwell duct and remove the duct (see illustration).

22 Extract the two studs securing the rear compartment duct to the matrix casing, and slide the duct rearwards.

23 Remove the two retaining clips at the base of the matrix housing.

24 Undo the two upper retaining bolts and remove the matrix housing from the car (see illustration).

25 Remove the seal from the top of the housing.

26 Undo the screw and remove the left-hand duct.

27 Release the clips around the upper face aperture, and remove the face panel.

28 Release the clips securing the two halves of the matrix housing, and separate the housing.

29 Remove the matrix.

**Refitting**

30 Refitting is a reversal of removal.

**Heater vacuum servo**

**Removal**

31 Disconnect the battery negative (earth) lead (refer to Chapter 5, Section 1).

32 Remove the trim panel under the fascia on the passenger's side.

33 Open the glovebox, undo the two screws securing the glovebox bar, and remove the glovebox.

34 Disconnect the air duct from the side of the heater blower assembly, and recover the two seals.

35 Disconnect the vacuum hose at the servo unit.

36 Extract the retaining spire clip, and release the servo arm from the heater lever.

37 Undo the two screws and remove the servo from the heater assembly.

**Refitting**

38 Refitting is a reversal of removal.

**Heater solenoid valve**

**Removal**

39 Proceed as described in paragraphs 31 to 34 above.

40 Disconnect the vacuum hose at the solenoid valve.

41 Disconnect the solenoid wiring multiplug.

42 Undo the retaining screw and remove the solenoid from the car.

**Refitting**

43 Refitting is a reversal of removal.

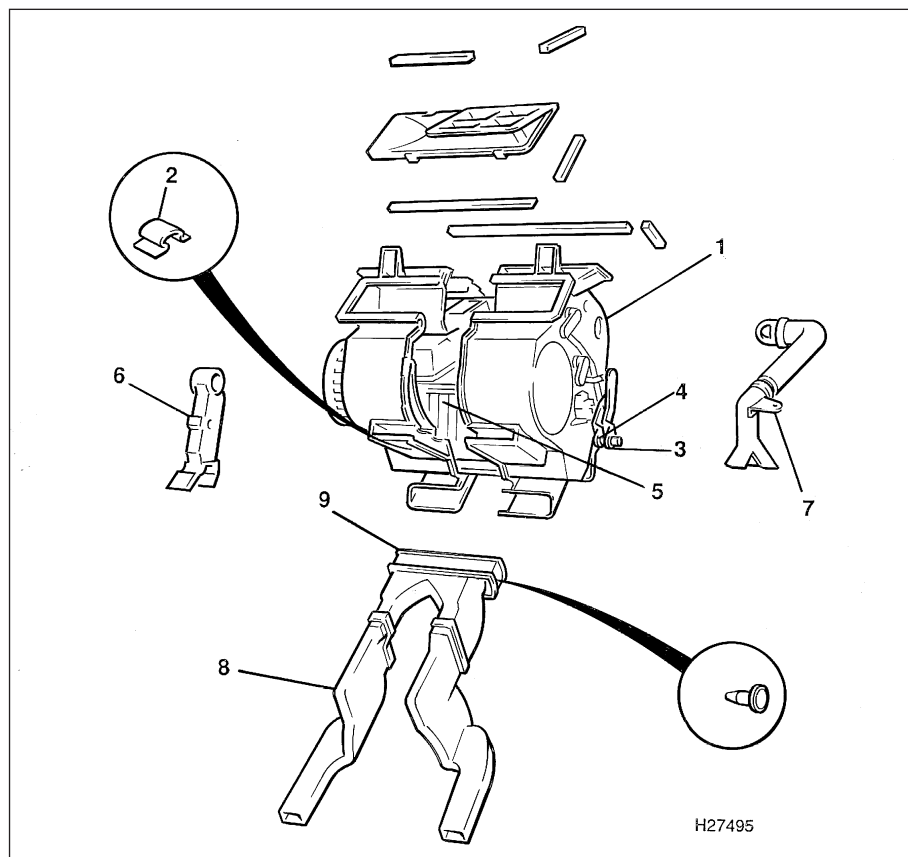

11.21 Exploded view of the matrix and housing assembly

- |                    |                      |              |
|--------------------|----------------------|--------------|
| 1 Housing assembly | 4 Distribution lever | 7 Duct       |
| 2 Clip             | 5 Heater matrix      | 8 Duct       |
| 3 Blend lever      | 6 Duct               | 9 Duct joint |

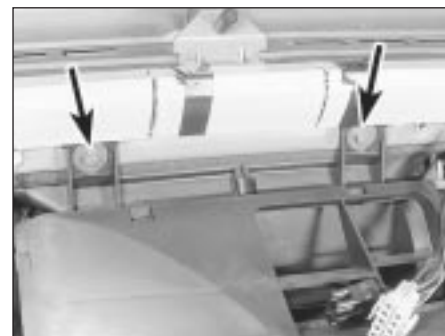

11.24 Matrix housing upper retaining bolts (arrowed)

## 12 Heater/air conditioning controls - removal and refitting



### Heater control unit and cables

#### Removal

- 1 Remove the cowl around the instrument panel as described in Chapter 12, Section 9.
- 2 Remove the trim panel under the facia on the driver's side.
- 3 Extract the outer cable retaining clips, and slip the cable ends off the heater levers.
- 4 Withdraw the control unit and cables from the facia.
- 5 Release the two inner and outer cables from the control unit.

#### Refitting

- 6 Refitting is a reversal of removal. When connecting the heater cables, adjust the position of the outer cables in their retaining clips so as to give full travel of the heater levers, consistent with full travel of the control levers.

### Air conditioning control unit

- 7 Refer to "Instrument cowl switch units" in Chapter 12, Section 4.

## 13 Air conditioning system - general information and precautions

### General information

The air conditioning system consists of a condenser mounted in front of the radiator, an evaporator mounted adjacent to the heater matrix, a compressor mounted on the engine, a receiver/dryer, and the plumbing connecting all of the above components (see illustration).

A blower fan forces the warmer air of the passenger compartment through the evaporator core (rather like a radiator in reverse), transferring the heat from the air to the refrigerant. The liquid refrigerant boils off into low-pressure vapour, taking the heat with it when it leaves the evaporator.

Two versions of the system are used, the change point being on models from VIN 152206 onwards. Both versions are virtually identical in component layout apart from minor differences in the condenser pipe connections. The main difference, however is that the later version uses the more environmentally friendly R134a refrigerant whereas the early version uses the ozone-depleting R12.

### Precautions



**Warning:** The air conditioning system is under high pressure. Do not loosen any fittings or remove any components until

after the system has been discharged. Air conditioning refrigerant should be properly discharged into an approved type of container, at a dealer service department or an automotive air conditioning repair facility capable of handling the refrigerant safely. Always wear eye protection when disconnecting air conditioning system fittings.

When an air conditioning system is fitted, it is necessary to observe the following special precautions whenever dealing with any part of the system, its associated components, and any items which necessitate disconnection of the system:

- (a) While the refrigerant used on later models - R134a - is less damaging to the environment than the previously-used R12, both are very dangerous substances. They must not be allowed into contact with the skin or eyes, or there is a risk of frostbite. They must also not be

discharged in an enclosed space as there is a risk of suffocation. The refrigerant is heavier than air, and so must never be discharged over a pit.

- (b) The refrigerant must not be allowed to come in contact with a naked flame, otherwise a poisonous gas will be created - under certain circumstances, this can form an explosive mixture with air. For similar reasons, smoking in the presence of refrigerant is highly dangerous, particularly if the vapour is inhaled through a lighted cigarette.
- (c) Never discharge the system to the atmosphere - R134a is not an ozone-depleting ChloroFluoroCarbon (CFC) as is R12, but is instead a hydrofluorocarbon, which causes environmental damage by contributing to the "greenhouse effect" if released into the atmosphere.
- (d) R134a refrigerant must **not** be mixed with R12; the system uses different seals and

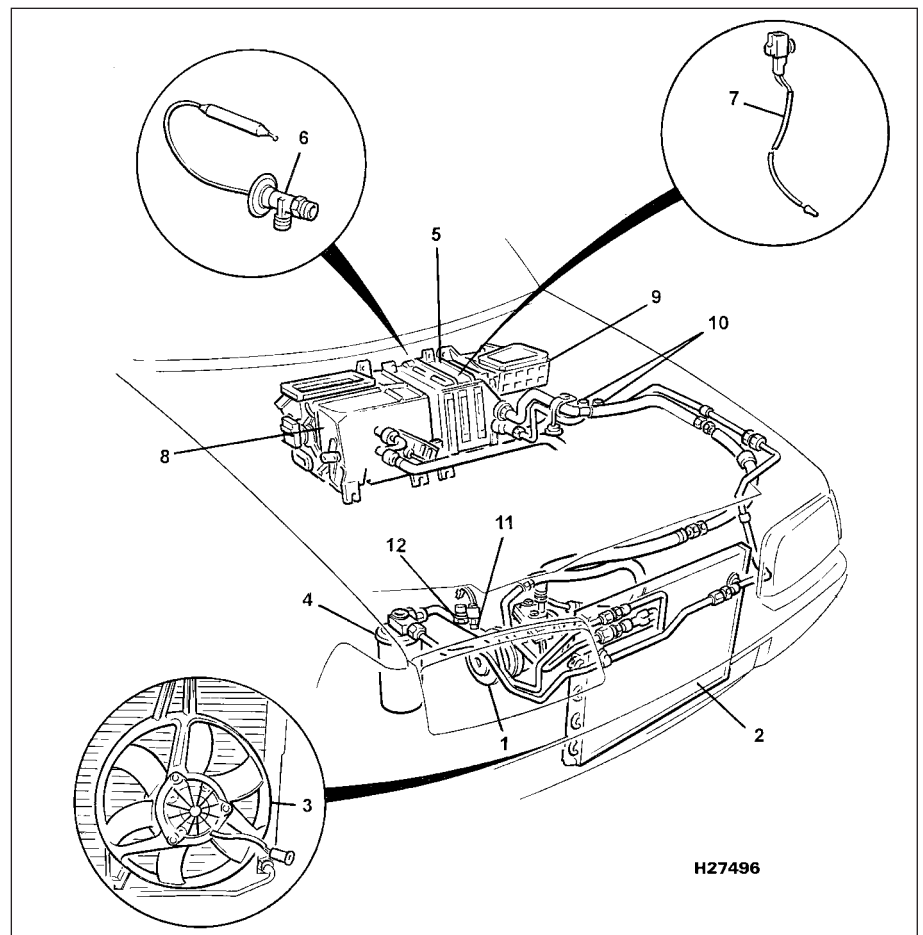

13.1 Air conditioning system layout (V6 engine installation shown - 4-cylinder engine installation similar)

- |                                  |                                      |  |
|----------------------------------|--------------------------------------|--|
| 1 Compressor                     | 6 Thermostatic expansion valve       | 9 Blower unit                                  |
| 2 Condenser                      | 7 Thermistor                         | 10 High and low pressure servicing connections |
| 3 Cooling fans (behind radiator) | 8 Heater distribution and blend unit | 11 High pressure switch                        |
| 4 Receiver/drier                 |                                      | 12 Dual pressure switch                        |
| 5 Evaporator                     |                                      |  |



has different fittings requiring different tools, so that there is no chance of the two types of refrigerant becoming mixed accidentally.

- (e) If for any reason the system must be disconnected, entrust this task to your Rover dealer or a refrigeration engineer.
- (f) It is essential that the system be professionally discharged prior to using any form of heat - welding, soldering, brazing, etc - in the vicinity of the system, before having the vehicle oven-dried at a temperature exceeding 70°C after repainting, and before disconnecting any part of the system.

### 14 Air conditioning system components - removal and refitting



**Warning:** Refer to the precautions given in the previous Section before proceeding.

#### Condenser

##### Removal

- 1 Have the refrigerant discharged at a dealer service department or an automotive air conditioning repair facility.
- 2 Disconnect the battery negative (earth) lead (see Chapter 5, Section 1).

3 On pre-1992 model year vehicles, remove the radiator grille as described in Chapter 11, Section 19.

4 Undo the two bolts each side securing the centre platform to the body side members.

5 Undo the two nuts securing the condenser to the front of the centre platform (see illustration).

6 Undo the nut and retaining bolt securing the bonnet safety catch to the centre platform.

7 Cut off the cable ties securing the various hoses to the centre platform.

8 Lift the centre platform upwards, turn it over, and cut off the cable ties securing the bonnet release cable to the platform underside. Remove the platform from the car.

9 On early models, using two spanners, one to unscrew the union nut and a second to counterhold the relevant pipe, unscrew the pipe unions on the front of the condenser. Where fitted, recover the O-rings from the pipe unions. Plug or cover the open pipes and condenser ports. On later models, undo the two pipe union retaining bolts and release the pipes. Recover the O-rings from the pipe connector ends.

10 Undo the bolts from the pipe support brackets and move the disconnected pipes aside.

11 Lift the condenser upwards, and carefully remove it from the car.

##### Refitting

12 Refitting the condenser is a reversal of

removal, but ensure that the lower mounting lugs engage in the rubber grommets, and the centre platform grommets locate over the radiator upper lugs. Re-secure the bonnet release cable and hoses to the centre platform, using new cable ties. Have the system evacuated, charged and leak-tested by the specialist who discharged it.

#### Compressor - 4-cylinder engines

##### Removal

13 Have the refrigerant discharged at a dealer service department or an automotive air conditioning repair facility.

14 Disconnect the battery negative (earth) lead (see Chapter 5, Section 1).

15 Raise the front of the vehicle and securely support it on axle stands.

16 Remove the auxiliary drivebelt (see Chapter 1).

17 Remove the alternator as described in Chapter 5.

18 Undo the bolts securing the alternator support bracket to the compressor and move the support bracket aside.

19 Disconnect the compressor clutch wiring at the in-line connector.

20 Unscrew the two pipe unions at the rear of the compressor and plug or cover the disconnected pipes and compressor ports. Where fitted, recover the O-rings from the pipe unions.

21 Undo the bolt securing the pipe bracket to the flange on the underside of the compressor.

22 Undo the upper and lower compressor mounting nuts and bolts and remove the unit upwards off the engine.

##### Refitting

23 Refitting the compressor is a reversal of removal. Tighten the unions and mountings to the specified torque. Have the system evacuated, charged and leak-tested by the specialist who discharged it.

#### Compressor - V6 engines

##### Removal

24 Have the refrigerant discharged at a dealer service department or an automotive air conditioning repair facility.

25 Disconnect the battery negative (earth) lead (see Chapter 5, Section 1).

26 Raise the front of the vehicle and securely support it on axle stands.

27 Remove the auxiliary drivebelt (see Chapter 1).

28 Disconnect the compressor clutch wiring at the in-line connector (see illustration).

29 Undo the four compressor mounting bolts and withdraw the compressor from the mounting bracket.

30 Undo the two bolts and release the pipe mounting flanges from the compressor. Recover the O-rings from the pipe unions and plug or cover the disconnected pipes and compressor ports.

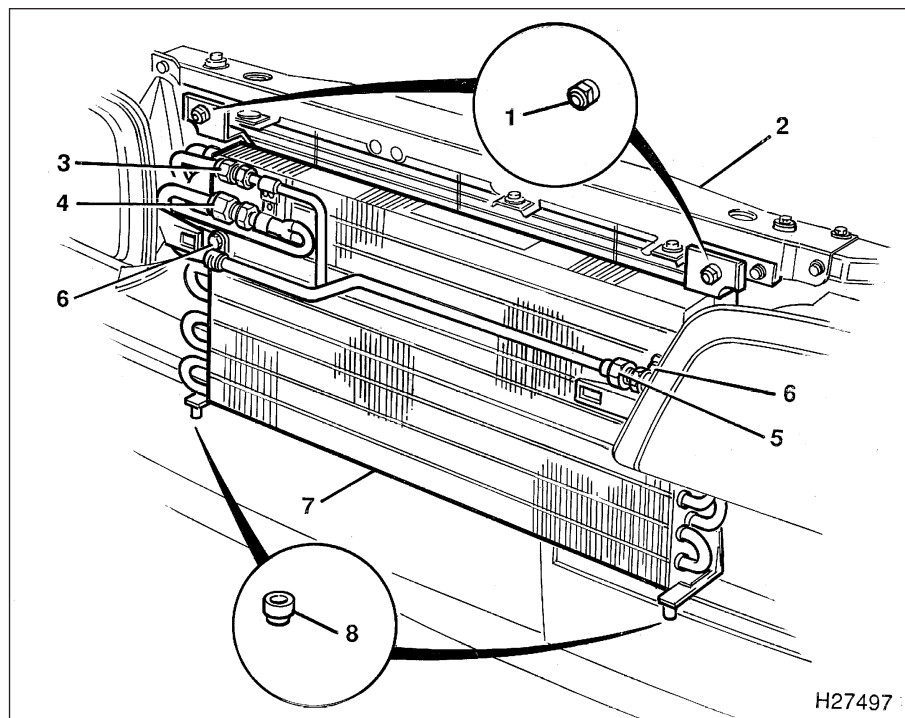

14.5 Air conditioning condenser mounting and attachment details (early version shown)

- |   |                  |                                      |
|---|------------------|--------------------------------------|
| 1 Condenser-to-centre platform retaining nuts | 4 Pipe union nut | 7 Condenser                          |
| 2 Centre platform                             | 5 Pipe union nut | 8 Lower mounting lug rubber grommets |
| 3 Pipe union nut                              | 6 Bracket        |                                      |

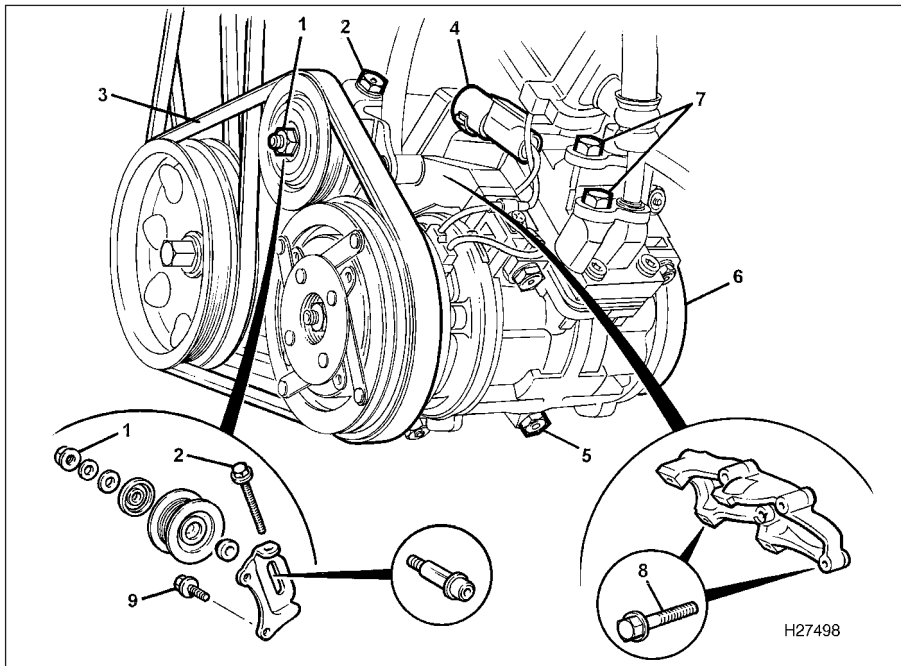

14.28 Air conditioning compressor mountings and attachments on V6 engines

- |                            |                             |                              |
|----------------------------|-----------------------------|------------------------------|
| 1 Tensioner pulley locknut | 4 Wiring connector          | 7 Pipe mounting flange bolts |
| 2 Tensioner adjuster bolt  | 5 Compressor mounting bolts | 8 Mounting bracket bolts     |
| 3 Drivebelt                | 6 Compressor                | 9 Tensioner bracket bolt     |

31 Working under the car, place a jack and block of wood under the engine to support it, then unscrew the eight bolts that secure the engine longitudinal support member by approximately 15 mm - it should not be necessary to remove the bolts. Have an assistant lever the support member down to give increased clearance, which will allow the compressor to be removed from the car.

#### Refitting

32 Refitting the compressor is a reversal of removal. Tighten the unions and all mountings to the specified torque. Have the system evacuated, charged and leak-tested by the specialist who discharged it.

#### Receiver/dryer

##### Removal

33 Have the refrigerant discharged at a dealer service department or an automotive air conditioning repair facility.

34 Unscrew the two pipe unions on top of the receiver/dryer and plug or cover the disconnected pipes and receiver/dryer ports (see illustration). Recover the O-rings from the pipe unions.

35 Undo the three mounting bolts, move the adjacent components clear and remove the unit from the car.

##### Refitting

36 Refitting the receiver/dryer is a reversal of removal. Tighten the unions and mountings to the specified torque. Have the system evacuated, charged and leak-tested by the specialist who discharged it.

#### Electric cooling fan assembly

37 Refer to Section 5.

#### Blower motor

##### Removal

38 Remove the trim panel under the facia on the passenger's side.

39 Disconnect the wiring multiplug from the motor socket.

40 Detach the hose from the motor and motor housing.

41 Undo the three bolts and remove the motor from the blower housing.

#### Refitting

42 Refitting is a reversal of removal.

#### Evaporator

##### Removal

43 Have the refrigerant discharged at a dealer service department or an automotive air conditioning repair facility.

44 Undo the five screws and remove the glovebox from the facia.

45 Remove the radio/cassette player and the clock as described in Chapter 12.

46 Undo the retaining screws and remove the glovebox bar.

47 From within the engine compartment unscrew the two pipe unions using two spanners, one to unscrew the union nut and a second to counterhold the relevant pipe. Recover the O-rings from the pipe unions. Plug or cover the disconnected pipes immediately.

48 Disconnect the thermistor wiring multiplug on the front face of the evaporator.

49 Undo the evaporator mounting nuts and bolts, noting the location of any cable support brackets and clips.

50 Disconnect the wiring at the connector multiplugs as the unit is withdrawn and remove the evaporator from the car.

##### Refitting

51 Refitting the evaporator is a reversal of removal. Tighten the unions and mountings to the specified torque. Have the system evacuated, charged and leak-tested by the specialist who discharged it.

#### Blower housing

##### Removal

52 Remove the evaporator as described previously.

53 Disconnect the wiring multiplugs, undo the mounting bolts and remove the unit from the car.

##### Refitting

54 Refitting is a reversal of removal.

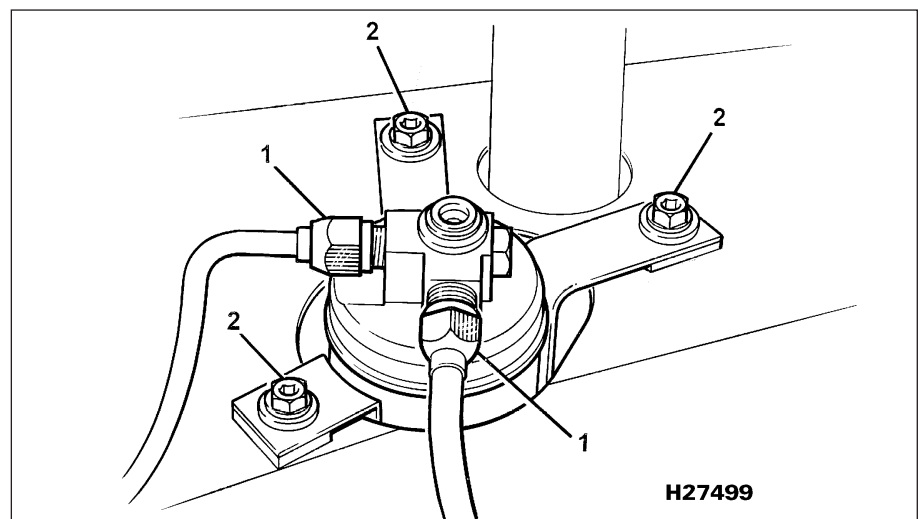





14.34 Air conditioning receiver/dryer pipe unions (1) and mounting bolts (2)

# Chapter 4 Part A: Fuel and exhaust systems – Single-point injection engines

## Contents

Accelerator cable - removal, refitting and adjustment . . . . .	3	Fuel injection system - testing and adjustment . . . . .	11
Accelerator pedal - removal and refitting . . . . .	4	Fuel injection system components - removal and refitting . . . . .	12
Accelerator cable and linkage check and lubrication . . . . .	See Chapter 1	Fuel pump - removal and refitting . . . . .	6
Air cleaner assembly - removal and refitting . . . . .	2	Fuel system - depressurisation . . . . .	5
Air cleaner element renewal . . . . .	See Chapter 1	Fuel tank - removal, inspection and refitting . . . . .	8
Exhaust manifold - removal and refitting . . . . .	See Chapter 2A	General information and precautions . . . . .	1
Exhaust system - general information and component renewal . . . . .	13	Inlet manifold - removal and refitting . . . . .	See Chapter 2A
Exhaust system check . . . . .	See Chapter 1	Underbody fuel/brake line check . . . . .	See Chapter 1
Fuel filter renewal . . . . .	See Chapter 1	Underbonnet check for fluid leaks and hose condition . . . . .	See Chapter 1
Fuel gauge sender unit - removal and refitting . . . . .	7	Unleaded petrol - general information and usage . . . . .	9
Fuel injection system - general information . . . . .	10		

## Degrees of difficulty

<b>Easy</b> , suitable for novice with little experience 	<b>Fairly easy</b> , suitable for beginner with some experience 	<b>Fairly difficult</b> , suitable for competent DIY mechanic 	<b>Difficult</b> , suitable for experienced DIY mechanic 	<b>Very difficult</b> , suitable for expert DIY or professional 
---	--	--	---	--

## Specifications

### General

System type . . . . .	Indirect single-point injection with microprocessor control
ECU-controlled idle speed:	
Manual transmission models . . . . .	700 to 800 rpm
Automatic transmission models . . . . .	650 to 750 rpm
Base idle speed:	
Manual transmission models . . . . .	625 to 675 rpm
Automatic transmission models . . . . .	575 to 625 rpm
Idle mixture CO content . . . . .	2.0 to 3.0%
Throttle potentiometer voltage . . . . .	315 to 335 mV
Throttle lever lost motion gap . . . . .	0.5 to 0.9 mm
Fuel octane rating . . . . .	97 RON leaded or 95 RON unleaded

### Fuel Pump

Type . . . . .	Nippon Denso, electric
Output pressure . . . . .	4.1 bar
Regulated pressure . . . . .	1.2 bar
Delivery rate (at 1.2 bar and 12 volts) . . . . .	85 litres/hour
Voltage at pump . . . . .	9.0 to 10.0 volts

### Torque wrench settings

	Nm	lbf ft
Inlet air temperature sensor . . . . .	7	5
Fuel filter banjo union bolts . . . . .	50	37
Throttle body to manifold nuts . . . . .	25	18
Fuel pump banjo union bolt . . . . .	22	16
Fuel tank drain plug . . . . .	50	37
Fuel tank strap locknuts . . . . .	18	13
Inlet manifold heater bolts . . . . .	10	7
Exhaust front pipe to manifold . . . . .	30	22
Exhaust section flange nuts . . . . .	30	22
Exhaust heat shield retaining bolts . . . . .	25	18



2.3a Lift up the air box . . .



2.3b . . . and disconnect the air temperature sensor multiplug



2.4a Disconnect the vacuum hose at the inlet manifold . . .

## 1 General information and precautions

The fuel system used on Rover 820e and Se models consists of a centrally-mounted fuel tank, electric fuel pump and single-point fuel injection (SPI) system, together with its related electrical and mechanical components. A more detailed description of the SPI system is contained in Section 10.

The exhaust system consists of a front, intermediate and rear section, suspended from the underbody on rubber mountings, and bolted to a cast iron manifold at the front. A ball-and-socket universal joint is incorporated in the front section, to allow for engine and exhaust system movement.

### Precautions



**Warning:** Many of the procedures in this Chapter require the removal of fuel lines and connections, which may result in some fuel spillage. Petrol is extremely flammable, so take extra precautions when you work on any part of the fuel system. Don't smoke, or allow open flames or bare light bulbs, near the work area. Don't work in a garage where a natural gas-type appliance (such as a water heater or clothes dryer) with a pilot light is present. If you spill any fuel on your skin, rinse it off immediately with soap and water. When you perform any kind of work

on the fuel system, wear safety glasses, and have a Class B type fire extinguisher on hand. Before carrying out any operation on the fuel system, refer also to the precautions given in "Safety first!" at the beginning of this manual, and follow them implicitly. Petrol is a highly-dangerous and volatile liquid, and the precautions necessary when handling it cannot be overstressed.

Reference must also be made to Chapter 5, Section 1 for precautionary notes concerning the ignition system and battery disconnection, and to any further safety-related text contained within the appropriate Section, before working on the vehicle.

Certain adjustment points in the fuel system are protected by tamperproof caps, plugs or seals. In some territories, it is an offence to drive a vehicle with broken or missing tamperproof seals. Before disturbing a tamperproof seal, first check that no local or national laws will be broken by doing so, and fit a new tamperproof seal after adjustment is complete, where required by law. Do not break tamperproof seals on any vehicle whilst it is still under warranty.

When working on fuel system components, scrupulous cleanliness must be observed and care must be taken not to introduce any foreign matter into the fuel lines or components. The throttle body in particular is a delicate instrument and care must be taken not to disturb any components unnecessarily. Before attempting work on the throttle body,

ensure that the relevant spares are available; it should be noted that a complete throttle body strip down is unlikely to cure a fault which is not immediately obvious, without introducing new problems. If persistent problems occur, it is recommended that the services of a Rover dealer or fuel injection specialist is sought.

## 2 Air cleaner assembly - removal and refitting



**Note:** Air cleaner element renewal is described in Chapter 1.

### Removal

1 Slacken the hose clip securing the intake trunking to the air cleaner body, and release the HT cable from the support clip.

2 Undo the five upper bolts securing the air box to the injector housing and support bracket.

3 Lift up the air box, and disconnect the wiring multiplug at the air temperature sensor, and the vacuum hose at the fuel trap (see illustrations).

4 Disconnect the vacuum hose from the inlet manifold connection, and from the vacuum motor on the air cleaner (see illustrations). Remove the air box and intake trunking assembly.

5 Undo the bolts securing the air cleaner body and the forward air trunking assembly to their support brackets (see illustrations). Lift



2.4b . . . and at the vacuum motor

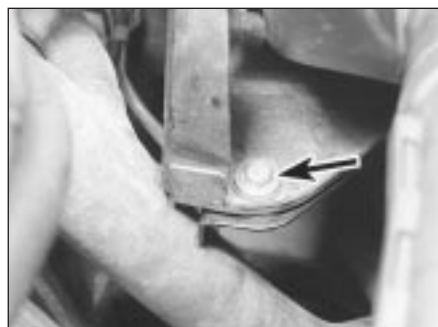

2.5a Undo the air cleaner body left-hand retaining bolt (arrowed) . . .

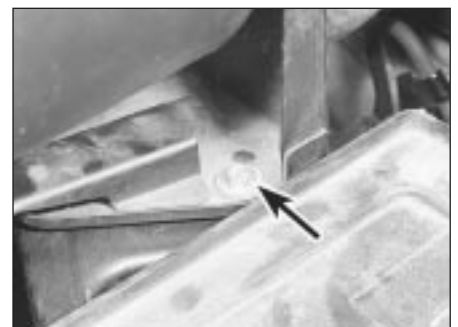

2.5b . . . right-hand retaining bolt . . .





2.5c ... and the air cleaner trunking to support bracket bolt (arrowed)

the body and trunking, disconnect the hot air intake tube, and release the trunking from the connecting duct at the front of the car. Remove the air cleaner body and trunking.  
**6** If the cold air side intake is to be removed, refer to Chapter 5, and remove the battery.  
**7** Undo the bolt securing the side intake to the body, and remove the intake and duct (see illustration).

**Refitting**

**8** Refitting is a reversal of removal, but ensure that all the ducts and trunking are fully engaged before tightening the various retaining bolts.

**3 Accelerator cable - removal, refitting and adjustment**



**Removal**

**1** Refer to Section 2 and remove the air cleaner air box.  
**2** Unscrew the accelerator cable locknut nearest to the cable end, pull the outer cable upwards, and slide the inner cable out of the slot in the support bracket (see illustration).  
**3** Release the inner cable end from the slot in the throttle cam (see illustration).  
**4** From inside the car, release the turnbuckles and lift out the trim panel over the clutch, brake and accelerator pedals.



3.3 ... and release the cable end (arrowed) from the throttle cam



2.7 Side intake to body retaining bolt (arrowed)

**5** Prise the retaining clip from the top of the accelerator pedal, and disconnect the inner cable.  
**6** Release the cable from the engine compartment bulkhead and from the support clips, and withdraw the complete cable from the car.

**Refitting and adjustment**

**7** Refitting is a reversal of removal. Adjust the cable initially by means of the outer cable locknuts, to give a small amount of free play with the throttle closed. On completion, check the base idle speed as described in Section 11.

**4 Accelerator pedal - removal and refitting**



**Removal**

**1** From inside the car, release the turnbuckles and lift out the trim panel over the clutch, brake and accelerator pedals.  
**2** Prise the retaining clip from the top of the accelerator pedal, and disconnect the inner cable from the pedal arm.  
**3** Undo the bolts securing the pedal bracket to the bulkhead, and withdraw the bracket and pedal assembly (see illustration).  
**4** Disconnect the switch wiring and remove the bracket and pedal.

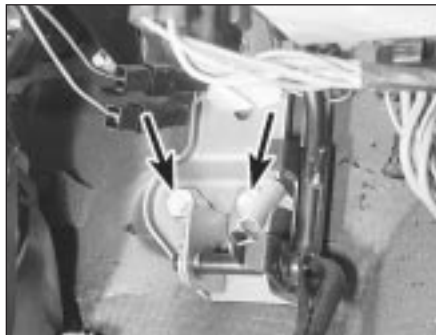

4.3 Accelerator pedal bracket retaining bolts (arrowed)



3.2 Undo the accelerator cable locknut ...

**5** If the accelerator pedal switch is to be removed, prise off the retaining C-clip and remove the switch and washer.

**Refitting**

**6** Refitting is a reversal of removal.

**5 Fuel system - depressurisation**



**Warning: Refer to the precautions contained in Section 1 before proceeding.**

**1** The fuel system referred to in this Chapter is defined as the fuel tank and tank-mounted fuel pump/fuel gauge sender unit, the fuel filter, the throttle body, and the metal pipes and flexible hoses of the fuel lines between these components. Most of these contain fuel which will be under pressure while the engine is running and/or while the ignition is switched on.  
**2** The pressure will remain for some time after the ignition has been switched off, and must be relieved before any of these components are disturbed for servicing or repair work.  
**3** Disconnect the battery negative (earth) lead (refer to Chapter 5, Section 1).  
**4** Place absorbent rags around the fuel filter outlet union banjo bolt, then slowly unscrew the bolt to release the pressure (see illustration).

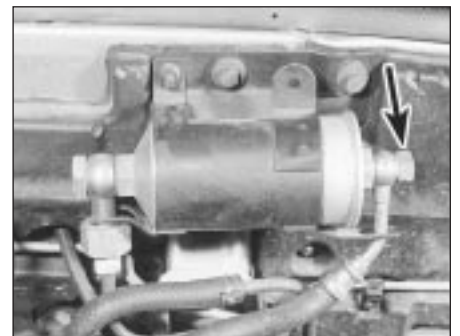

5.4 Place absorbent rags around the fuel filter outlet union banjo bolt (arrowed), then slowly unscrew the bolt to release the system pressure

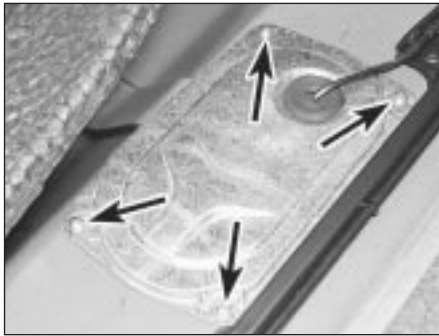

6.8a Undo the four screws (arrowed) . . .



6.8b . . . and lift off the fuel pump access panel

5 Once the system pressure has been completely relieved, tighten the banjo bolt and dispose of the rags safely.

## 6 Fuel pump - removal and refitting



**Warning:** Refer to the precautions contained in Section 1 before proceeding.

### Removal

- 1 Disconnect the battery negative (earth) lead (refer to Chapter 5, Section 1).
- 2 Release the fuel system pressure as described in Section 5.
- 3 Remove the floor carpet from the luggage compartment.
- 4 Refer to Chapter 11 and remove the rear seats.
- 5 Release the eight studs and remove the seat squab backing from the body.
- 6 Release the two studs and remove the luggage compartment backboard from the body.
- 7 Remove the cover board over the spare wheel, and remove the tool kit.
- 8 Undo the four screws and lift off the pump access panel (see illustrations). Move the panel to one side.
- 9 Disconnect the pump wiring multiplug, then unscrew the fuel hose banjo union bolt and recover the copper washers (see illustration).

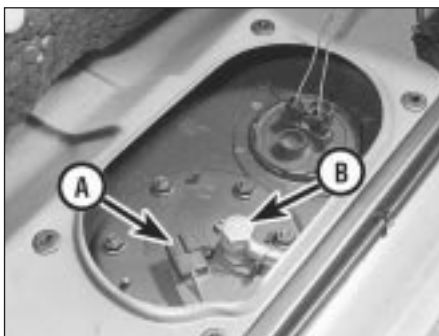

6.9 Fuel pump wiring multiplug connection (A) and fuel hose banjo union (B)

10 Slacken the clip and disconnect the fuel return hose.

11 Undo the pump retaining nuts, and withdraw the pump from the tank. Remove the seal from the pump flange.

### Refitting

12 Refitting is a reversal of removal, but renew the flange seal if it shows any sign of deterioration.

## 7 Fuel gauge sender unit - removal and refitting



**Warning:** Refer to the precautions contained in Section 1 before proceeding.

### Removal

- 1 Follow the procedure given in Section 6, paragraphs 1 to 8 inclusive, with the exception of paragraph 2.
- 2 Disconnect the two leads at the sender unit.
- 3 Engage a screwdriver, flat bar or other tool with the lugs of the locking ring, and turn the ring anti-clockwise to release it.
- 4 Withdraw the locking ring, seal and sender unit.

### Refitting

5 Refitting is a reversal of removal, but renew the seal if it shows any sign of deterioration.



8.12 Fuel tank retaining strap and locknut

## 8 Fuel tank - removal, inspection and refitting



**Warning:** Refer to the precautions contained in Section 1 before proceeding.

### Removal

- 1 Follow the procedure given in Section 6, paragraphs 1 to 8 inclusive.
- 2 Disconnect the fuel pump wiring multiplug, and the two leads at the fuel gauge sender unit.
- 3 Remove the fuel tank filler cap.
- 4 With sealed containers handy, undo the drain plug at the base of the tank, and drain the fuel into the containers. Recover the drain plug sealing washer. When all the fuel has drained, refit the plug, using a new sealing washer if necessary.
- 5 Chock the front wheels, remove the rear wheel trim and slacken the wheel nuts. Jack up the rear of the car and support it on axle stands. Remove the left-hand rear roadwheel.
- 6 Slacken the retaining clip and disconnect the filler hose from the filler neck. Move the hose aside.
- 7 Slacken the retaining clips and disconnect the five breather hoses from the breather pipes.
- 8 Refer to Section 13 and remove the exhaust system rear and intermediate sections, together with the rear heat shield.
- 9 Slacken the retaining clip and disconnect the fuel return hose from the pipe on the side of the tank. Plug the disconnected pipe and hose.
- 10 Undo the union connector and disconnect the fuel feed hose from the pipe. Plug the disconnected pipe and hose.
- 11 Support the tank on a jack with interposed block of wood.
- 12 Slacken the two tank retaining strap locknuts, release the hook bolts from the body slots, and move the straps clear (see illustration).
- 13 Lower the tank and remove it from under the car.
- 14 If the tank is contaminated with sediment or water, remove the sender unit as described in Section 7, and swill the tank out with clean fuel. If the tank is damaged, or leaks, it should be repaired by a specialist, or renewed. **Do not** under any circumstances solder or weld the tank.

### Refitting

15 Refitting is a reversal of removal.

## 9 Unleaded petrol - general information and usage

**Note:** The information given in this Chapter is correct at the time of writing, and applies only to petrols currently available in the UK. If updated information is thought to be required, check with a Rover dealer. If travelling abroad,

consult one of the motoring organisations (or a similar authority) for advice on the petrols available and their suitability for your vehicle.

1 The fuel recommended by Rover is given in the Specifications at the beginning of this Chapter, followed by the equivalent petrol currently on sale in the UK.

2 RON and MON are different testing standards.; RON stands for Research Octane Number (also written as RM), while MON stands for Motor Octane Number (also written as MN).

3 All non-catalyst equipped 4-cylinder engine models covered by this manual are designed to run on leaded or unleaded petrols without modification. Only unleaded petrol may be used in those models fitted with a catalytic converter.

## 10 Fuel injection system - general information

The single-point fuel injection (SPI) system is a microprocessor-controlled fuel management system, designed to overcome the limitations associated with conventional carburettor induction (see illustration). This is achieved by continuously monitoring the engine using various sensors, whose data is input to the fuel system Electronic Control Unit (ECU). Based on this information, the ECU program and memory then determine the exact amount of fuel necessary, which is injected into the throttle body by a single injector, for all actual and anticipated driving conditions.

The main components of the system and their individual operation is as follows.

**Fuel/ignition ECU:** The fuel ECU is a microprocessor which controls the injector opening time, and therefore the amount of fuel supplied. Contained in the ECU memory is a program from which a pulse is derived, the length of which determines the fuel injector opening duration. Information received from the various engine sensors will cause the ECU to alter the fuel requirements, by changing the pulse length. Airflow measurement is based on the speed/density method, in which the inlet air temperature and inlet manifold pressure are measured under the assumption that the engine is a calibrated vacuum pump, with its characteristics stored in the ECU memory. The air/fuel ratio requirements for all engine speeds and loads are also stored in the ECU. This information on the engine's basic fuel requirements is constantly amended, according to the information received from the various sensors. In addition to this, the engine idle speed is also controlled by the ECU, which uses a stepper motor to open or close the throttle as required. Two separate programs control the ECU functions. One program operates under cruise conditions, and the other at idle. The idle program can be altered completely using

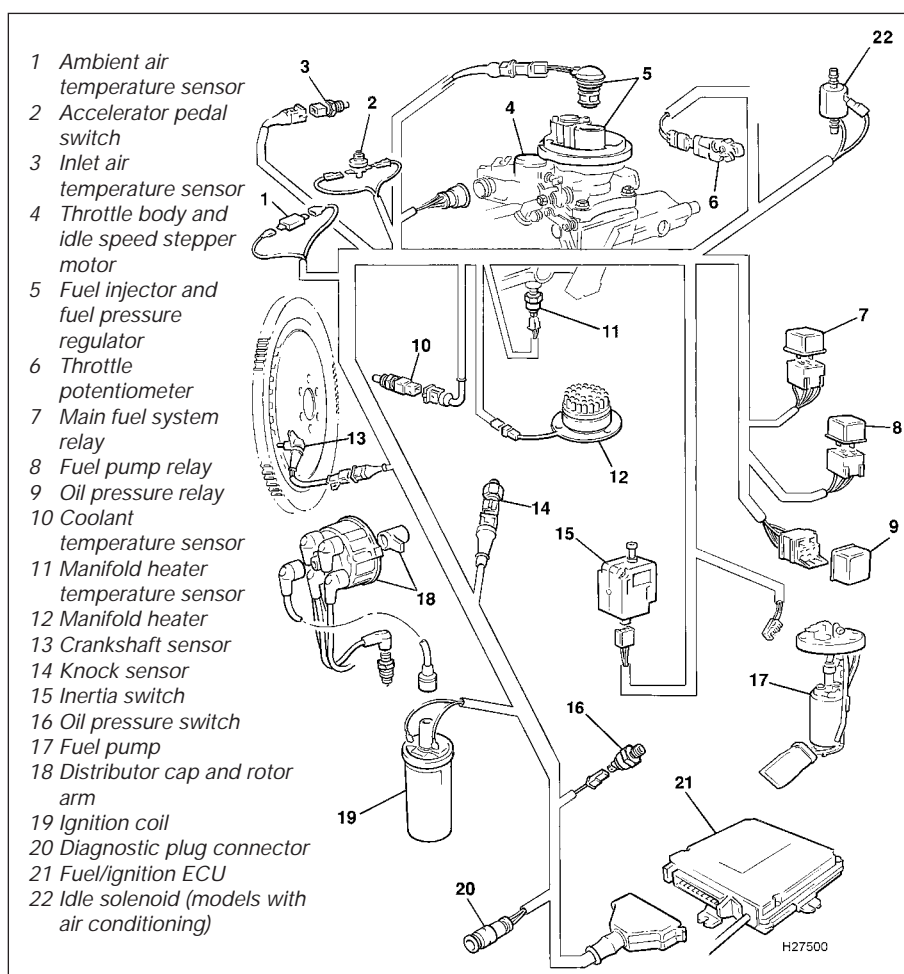

10.1 Main components of the single-point fuel injection system

electronic test equipment, or partially by using the procedures described in Section 11. Any changes to this program do not affect the cruise program, which cannot be accessed. Whenever the battery is disconnected, the idle program is lost, and the ECU reverts back to a set of nominal parameters until the information is reintroduced into the memory. This can only be done using the manufacturer's test equipment, but the performance of the engine at idle is only marginally affected in this condition. As well as control of the fuel injection system, the ECU is also used to control the ignition timing.

**Fuel injector:** The single fuel injector is a solenoid-operated ball valve, containing a fine gauze filter and a nozzle with six spray holes for complete fuel atomization. When a pulse is received from the ECU, the injector sprays fuel into the air stream through the throttle body.

**Throttle potentiometer:** The potentiometer is a variable resistor, attached to the throttle shaft on the throttle body. The unit is supplied with a constant input voltage, and as the resistance of the potentiometer varies with throttle shaft movement, the output voltage is proportionally affected. This allows the ECU

to determine throttle valve position, and rate of change.

**Idle speed stepper motor:** This is a small electric motor, having four control windings to enable it to rotate in either direction. Under a signal from the ECU, the stepper motor will rotate in whichever direction is necessary, to open or close the throttle by means of pushrod acting directly against the base idle speed adjusting screw.

**Inlet air temperature sensor:** Located in the airflow through the air cleaner air box, the sensor is a thermistor (resistive device whose resistance quickly decreases with temperature increase).

**Coolant temperature sensor:** This resistive device is screwed into the thermostat housing, where its element is in direct contact with the engine coolant. Changes in coolant temperature are detected by the ECU as a change in the sensor resistance.

**Ambient air temperature sensor:** The sensor is located behind the left-hand headlight, and responds to changes in ambient temperature with a corresponding change in resistance.

**Manifold heater:** A manifold heater, to improve atomization of the fuel/air mixture



during warm-up conditions, is fitted to the underside of the inlet manifold. The heater is of the positive temperature coefficient (PTC) type, in which the current consumption of the heating element is high while it heats up, but is greatly reduced at operating temperature. The unit is controlled by a temperature sensor, screwed into the coolant jacket of the inlet manifold. When coolant temperature reaches 50°C, the sensor switches the manifold heater off. To avoid a heavy drain on the battery, current for the heater is supplied via the oil pressure switch relay, and consequently only switches on after the engine has started.

**Fuel pressure regulator:** The fuel pressure regulator is attached to the throttle body, and maintains fuel pressure at a constant 1.0 bar. When the pressure exceeds this value, the regulator returns excess fuel to the tank via the fuel return line.

**Inertia switch:** An inertia switch is fitted in the ignition switch feed to the fuel pump relay, and is situated inside the car behind the left-hand side of the radio cassette player. In the event of sudden impact, the switch trips out, thus switching off the fuel pump relay. The switch can be reset by pressing down the reset button on the switch body.

**Relays:** The main fuel system relay is energised when the ignition is switched on, and supplies current to the ignition coil and the fuel system ECU. The relay remains energised for approximately five seconds after the ignition is switched off, to enable the stepper motor to cycle to the correct position for engine starting. The fuel pump relay is energised when the oil pressure relay is de-energised by the low oil pressure switch. When the engine is cranking, the fuel pump is fed from the starter solenoid via the de-energised fuel pump relay.

**Fuel pump:** The fuel pump is a self-priming centrifugal unit, located in the fuel tank, and totally submerged in the fuel. Fuel is supplied under pressure from the pump, through a non-return valve and in-line filter, to the fuel pressure regulator, and then to the fuel injector. The high capacity output of the pump is reduced by a resistive wire in the harness which reduces the supply voltage.

**Accelerator pedal switch:** When the

accelerator pedal is at rest, the pedal switch is closed, and a signal is sent to the ECU indicating that the engine is idling. On receipt of this information, the ECU selects the idle program from its memory, and automatic idle speed control via the stepper motor is implemented.

### 11 Fuel injection system - testing and adjustment



#### Testing

**1** If a fault appears in the fuel injection system, first ensure that all the system wiring connectors are securely connected and free of corrosion. Then ensure that the fault is not due to poor maintenance; ie, check that the air cleaner filter element is clean, the spark plugs are in good condition and correctly gapped, the cylinder compression pressures are correct, and that the engine breather hoses are clear and undamaged, referring to the relevant Sections of this Chapter, and to Chapters 1 and 2 for further information.

**2** If these checks fail to reveal the cause of the problem, the vehicle should be taken to a suitably equipped Rover dealer for testing on Rover dedicated test equipment. This equipment will locate the fault quickly and simply, alleviating the need to test all the system components individually, which is a time-consuming operation that carries an element of risk of damaging the ECU.

#### Adjustment

##### Engine tuning procedure

**3** Before making any changes to the settings of the fuel injection system, ensure that the spark plug gaps are correctly set, the air cleaner element is clean, there are no leaks in the exhaust system, and the ignition system is operating correctly. Ensure that all breather and vacuum hoses are connected, and that none are perished or kinked.

**4** Temperature effects, and engine and transmission oil drag, can adversely influence the base idle speed setting, and it is important that the following warm-up procedure is adopted before attempting any adjustments.

**5** Drive the car on the road for approximately two to four miles, dependent on summer or winter conditions, in a normal manner, without excessive load, engine speed or road speed.

**6** Return the car to the working area, switch off and connect a tachometer, following the equipment manufacturer's instructions.

**7** Start the engine again, and run it at 2000 rpm for ten seconds to stabilise the mixture. The adjustment procedure described in the following paragraphs can now commence. If during the procedure the cooling fan operates, or if adjustment is not completed within two minutes, accelerate the engine to 2000 rpm again, by means of the throttle linkage (not the accelerator pedal) and hold this speed for a further ten seconds. Repeat this every two minutes until the adjustments are completed.

##### Base idle speed and mixture adjustment

**8** The function of the fuel injection system is such that the base idle speed and idle mixture settings are controlled by the ECU, and of these two, only the base idle speed can be adjusted without the use of the manufacturer's test equipment. Should poor idle quality be experienced, the base idle speed should be checked, and if necessary adjusted, using the following procedure. The idle mixture setting will not normally require attention unless the battery is disconnected, in which case the settings in the ECU memory will be lost. If the battery is disconnected for any reason, the ECU can be recalibrated using the procedure described in paragraphs 21 to 28 as a temporary measure.

**9** Refer to the engine tuning procedure above before starting.

**10** Switch off the engine, and ensure also that all electrical circuits are switched off throughout the procedure.

**11** Undo the five bolts and lift off the air cleaner box. Place the air box alongside the engine, without disconnecting any of the hoses or ducts.

**12** Operate the throttle by hand, and check that it opens fully and returns to rest against the stepper motor pushrod.

**13** Start the engine and using the throttle linkage, not the accelerator pedal, increase the engine speed to 1200 rpm, and hold it at this speed. Check that the stepper motor pushrod has retracted fully, then disconnect the stepper motor multiplug (the round plug on the side of the throttle body below the accelerator cable).

**14** Release the throttle and allow the engine to stabilise at idle speed.

**15** Check the engine base idle speed on the tachometer, and compare the reading with the figure given in the Specifications. If adjustment is required, slacken the adjusting screw locknut and turn the adjusting screw as necessary to obtain the correct setting (see illustrations). Tighten the locknut when the speed is correct.



11.15a Slacken the base idle speed adjusting screw locknut . . .



11.15b . . . and turn the adjusting screw (arrowed) to obtain the correct setting





11.16a Insert a feeler gauge between the throttle lever and peg . . .

16 Check the lost motion gap by inserting a feeler gauge of the specified size between the forked end of the throttle lever and the peg on the linkage. If the gap requires adjustment, slacken the accelerator cable locknuts and reposition the outer cable until the correct setting is achieved (see illustrations). Tighten the locknuts when the gap is correct.

- 17 Reconnect the stepper motor multiplug.
- 18 Switch off the ignition, wait three seconds and switch the ignition on once more. After a further three seconds, switch off the ignition again. The stepper motor will now be in the correct position for the next engine start.
- 19 On cars equipped with automatic transmission, refer to Chapter 7, Part B and check the kickdown cable adjustment.
- 20 Refit the air cleaner air box and disconnect the tachometer on completion.

**Electronic control unit calibration**

21 As previously stated, whenever the battery is disconnected, the idle mixture setting stored in the ECU memory will be lost. On reconnection of the battery, the following procedure may be used to recalibrate the unit temporarily, until such time as the car can be taken to a dealer for accurate setting on Rover dedicated test equipment.

- 22 Run the engine with all electrical circuits switched off, until the engine cooling fan operates then stops.
- 23 Switch off the engine immediately the cooling fan stops.
- 24 Switch the ignition on to position two of the key.



11.16b . . . and adjust the lost motion gap at the accelerator cable

25 Depress the accelerator pedal through at least half its travel, then release it, five times.

- 26 Wait until the high engine temperature warning light starts to flash.
- 27 As soon as the high engine temperature warning light stops flashing, start the engine without depressing the accelerator pedal, and allow it to idle. If the accelerator pedal is depressed, or if an electrical unit is switched on, the calibration will cease. (This also applies to the interior lights operated by the door pillar switches, so keep the doors closed).
- 28 Wait for two to three minutes until the warning light flashes again, indicating that calibration is complete.

**12 Fuel injection system components - removal and refitting**



**Note:** Refer to the precautions contained in Section 1 before proceeding.

**Thermac switch**

**Removal**

- 1 Refer to Section 2 and remove the air cleaner air box.
- 2 Disconnect the two vacuum hoses at the thermac switch on the base of the air box (see illustration).
- 3 Remove the air box intake trunking for access to the switch.
- 4 Carefully prise off the switch retaining clip, and remove the switch from inside the air box.

**Refitting**

5 Refitting is a reversal of removal, but position the unit so that the large diameter pipe is towards the air temperature sensor. Connect the vacuum hose from the manifold to the pipe with the small diameter hole, and the vacuum hose from the air cleaner vacuum motor to the pipe with the large diameter hole.

**Inlet air temperature sensor**

**Removal**

- 6 Refer to Section 2 and remove the air cleaner air box.
- 7 Unscrew the sensor from the adaptor on the base of the air box. If the adaptor unscrews with the sensor, unscrew the adaptor and refit it to the air box.

**Refitting**

8 Refit the sensor to the adaptor, and refit the air box.

**Throttle potentiometer**

**Removal**

- 9 Refer to Section 2 and remove the air cleaner air box.
- 10 Disconnect the multiplug from the side of the potentiometer body.
- 11 Using a dab of paint, mark the position of the throttle potentiometer in relation to the mounting adaptor.
- 12 Undo the two screws, remove the potentiometer, and lift off the adaptor (see illustration).

**Refitting**

13 Refitting is a reversal of removal. Ensure that the potentiometer lever engages to the right of the throttle lever, and align the previously-made mark before tightening the retaining screws. Have the potentiometer position adjusted accurately by a Rover dealer on completion.

**Injector housing**

**Removal**

- 14 Relieve the fuel system pressure as described in Section 5.
- 15 Refer to Section 2 and remove the air cleaner air box.
- 16 Using pliers, release the two fuel hose retaining clips at the injector housing, and disconnect the two hoses (see illustration). Plug the hoses after removal.



12.2 Thermac switch vacuum hoses (arrowed)

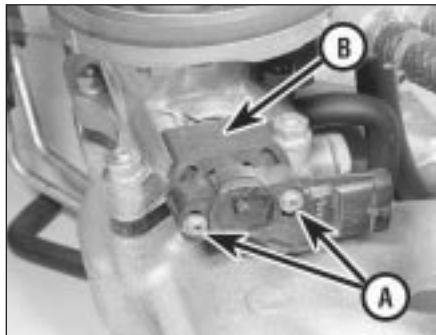

12.12 Throttle potentiometer retaining screws (A) and adaptor (B)



12.16 Release the two fuel hose retaining clips at the injector housing, and disconnect the two hoses

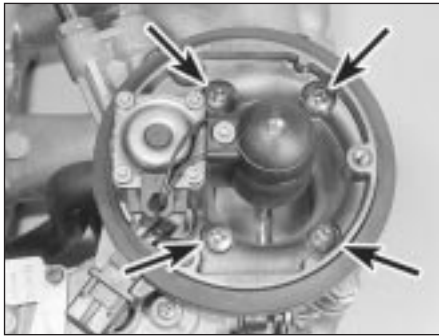

12.18 Injector housing retaining screws (arrowed)

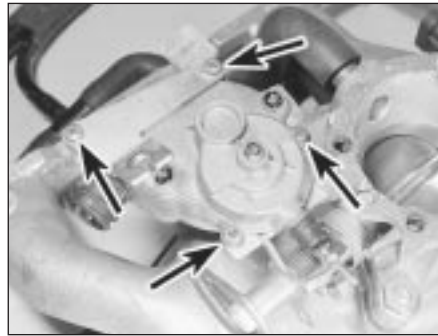

12.28 Undo the four stepper motor retaining screws (arrowed) . . .

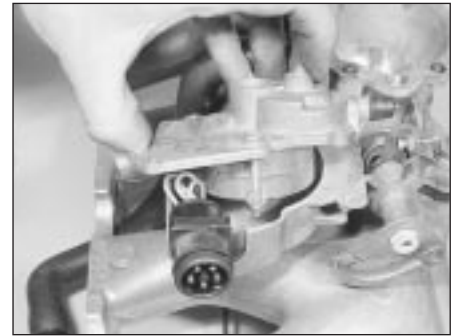

12.30 . . . and lift off the stepper motor

17 Disconnect the injector wiring multiplug.  
 18 Undo the four screws securing the injector housing to the throttle body, and lift off the housing (see illustration). The housing may be initially tight, due to the two locating dowels. Recover the gasket from the throttle body.

19 This is the limit of dismantling that can be undertaken on the injector housing assembly. Should it be necessary to renew the fuel injector or fuel pressure regulator, a complete injector housing assembly must be obtained.

20 Clean the mating faces of the injector housing and throttle body, and remove all the old locking compound from the threads of the retaining screws. Obtain a new gasket if the original shows any signs of deterioration.

#### Refitting

21 Place the gasket in position on the throttle body, and locate the injector housing over the gasket.

22 Apply a thread-locking compound to the four retaining screws, then fit and tighten the screws securely.

23 Reconnect the injector wiring multiplug.

24 Reconnect the two fuel hoses, then locate the retaining clips 3.0 mm from the hose ends.

25 Refit the air cleaner air box, then adjust the engine base idle speed as described in Chapter 1.

#### Stepper motor unit

##### Removal

26 Remove the injector housing as previously described.

27 Disconnect the wiring multiplug from the side of the stepper motor.

28 Undo the four outermost screws that secure the stepper motor to the throttle body (see illustration). Do not remove the two screws near the centre of the unit.

29 Lift off the accelerator cable support bracket, with cable still attached, and place it to one side.

30 Carefully lift off the stepper motor unit and, where fitted, recover the gasket (see illustration). Note that the gasket was only fitted to early models, and if present, discard it, and do not fit another on reassembly.

31 Clean the components with a clean cloth, and remove all the old locking compound from the threads of the retaining screws.

#### Refitting

32 Refitting is a reversal of removal, but use a thread-locking compound on the retaining screw threads.

#### Throttle body

##### Removal

33 Remove the injector housing as previously described.

34 Disconnect the wiring multiplugs to the stepper motor and throttle potentiometer.

35 Disconnect the two breather hoses on the side of the throttle body (see illustration).

36 Slacken the accelerator cable locknuts, open the throttle fully and slip the cable end out of the throttle cam. Unscrew the lower cable locknut fully, and remove the accelerator cable from the support bracket.

37 On automatic transmission models, disconnect the kickdown cable, using the same procedure as for the accelerator cable.

38 Undo the four nuts securing the throttle body to the manifold.

39 Lift off the throttle body, and recover the manifold spacer, with gaskets.

40 Clean the mating faces on the manifold and throttle body, and renew the gaskets on the spacer if they show any sign of deterioration. If the gaskets are being renewed, attach them to the spacer using non-drying jointing compound.



12.35 Breather hose attachments at the throttle body

#### Refitting

41 Place the spacer with gaskets over the manifold studs, then place the throttle body in position. Secure the throttle body with the four nuts tightened securely.

42 Reconnect the breather hoses and the wiring multiplugs.

43 Refit the accelerator cable and adjust it, by means of the locknuts, to give a small amount of free play in the throttle-closed position.

44 On automatic transmission models, refit and adjust the kickdown cable as described in Chapter 7, Part B.

45 Refit the injector housing as described previously.

#### Electronic control unit (ECU)

##### Removal

46 Disconnect the battery negative (earth) lead (refer to Chapter 5, Section 1).

47 Disconnect the wiring multiplug from the ECU, which is located on the left-hand side of the engine compartment behind the battery. To do this, press the retaining tab upwards, release the bottom of the multiplug, then disengage the top lug (see illustration).

48 Disconnect the vacuum supply hose.

49 Undo the two retaining screws, disengage the locating lug and remove the unit from its mounting bracket.

##### Refitting

50 Refitting is a reversal of removal.



12.47 Disconnect the ECU wiring multiplug

## Resonator unit

### Removal

- 51 Apply the handbrake, jack up the front of the car and support it on axle stands.
- 52 Undo the two screws and one bolt securing the access panel to the underside of the front wheelarch on the left-hand side.
- 53 Disengage the access panel from the front spoiler, and remove it from under the car.
- 54 Undo the two bolts and withdraw the resonator from under the front wheelarch.
- 55 Remove the spacers and rubber mountings from the resonator.

### Refitting

- 56 Refitting is a reversal of removal.

## Inertia switch

### Removal

- 57 From inside the car, remove the stud from the centre console side cover on the left-hand side, and remove the cover.
- 58 Undo the two screws securing the inertia switch to the mounting plate, disconnect the wiring multiplug and remove the switch.
- 59 Check the operation of the switch by striking the forward-facing side hard against the palm of your hand. The setting button should trip out when this is done. If not, renew the switch.

### Refitting

- 60 Refitting is a reversal of removal. Press the button down to reset the switch after installation.

## Manifold heater

### Removal

- 61 Disconnect the battery negative (earth) lead (refer to Chapter 5, Section 1).
- 62 Refer to Section 2 and remove the air cleaner air box.
- 63 Relieve the fuel system pressure as described in Section 5.
- 64 Release the clips and disconnect the two fuel hoses at the injector housing.
- 65 Disconnect the manifold heater wiring connector.
- 66 Undo the two bolts securing the fuel pipe clips and the heater to the manifold, and move the pipes aside.
- 67 Undo the remaining heater retaining bolt.
- 68 Open the throttle fully, and remove the heater by pushing down with a long screwdriver through the throttle aperture.
- 69 Remove the O-ring and gasket from the heater.
- 70 Clean the mating faces of the heater and manifold, and renew the gasket and O-ring if they show any sign of deterioration.

### Refitting

- 71 Refitting is a reversal of removal.

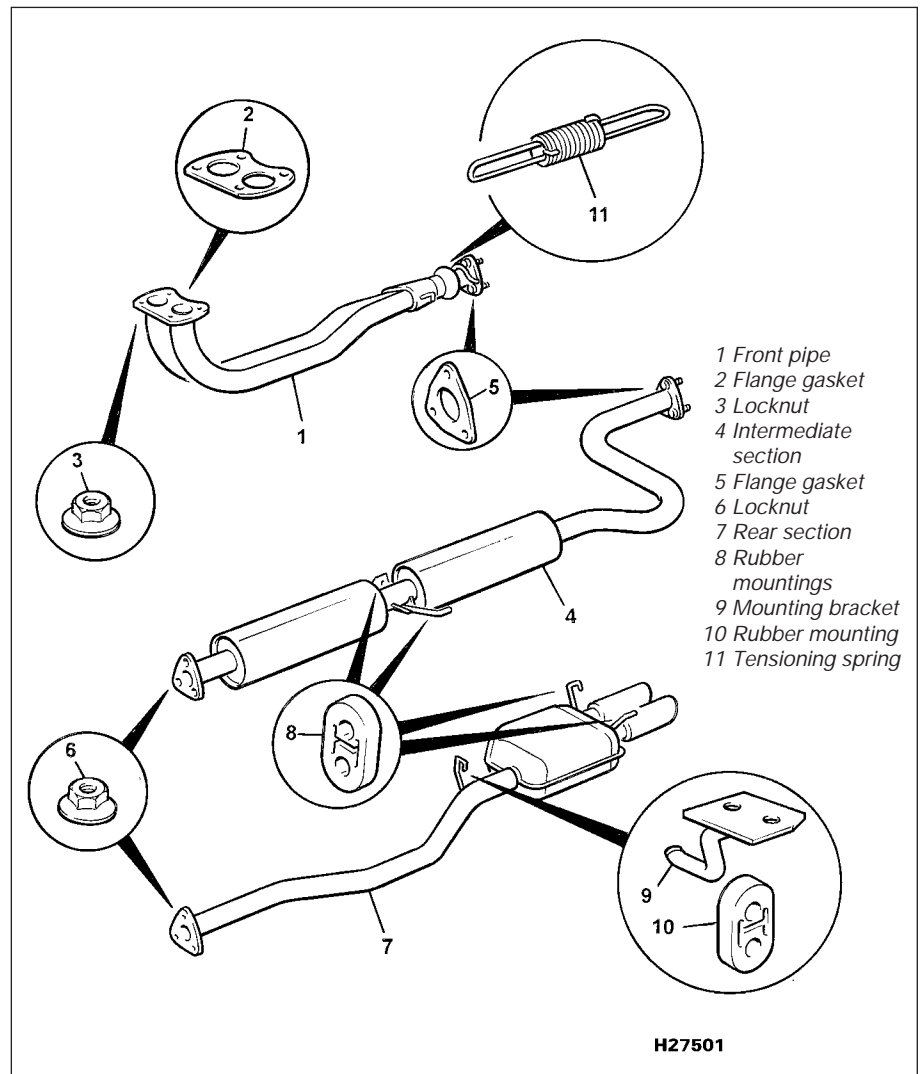

13.1 Exhaust system components

## 13 Exhaust system - general information and component renewal



**Warning:** Inspection and repair of exhaust system components should be done only after enough time has elapsed after driving the vehicle to allow the system components to cool completely. Also, when working under the vehicle, make sure it is securely supported on axle stands.

### General information

- 1 The exhaust system consists of a front, intermediate and rear section, suspended from the underbody on rubber mountings, and bolted to a cast iron manifold at the front. A ball-and-socket universal joint is incorporated in the front section, to allow for engine

and exhaust system movement (see illustration).

2 The exhaust system should be examined for leaks, damage and security at regular intervals (see Chapter 1). To do this, apply the handbrake, and allow the engine to idle in a well-ventilated area. Lie down on each side of the car in turn, and check the full length of the system for leaks, while an assistant temporarily places a wad of cloth over the end of the tailpipe. If a leak is evident, stop the engine and use a proprietary repair kit to seal it. If the leak is excessive, or damage is evident, renew the section. Check the rubber mountings for deterioration, and renew them if necessary.

### Component renewal

#### Removal

- 3 To renew the system components, raise the vehicle by means of axle stands or ramps to provide adequate working clearance underneath.

## 4A•10 Fuel and exhaust systems - single-point injection engines

---

**4** To remove the rear section, undo the three nuts securing the rear section to the intermediate section at the flange joint, and separate the joint. Recover the flange gasket. Disengage the rubber mountings at the side and rear, and remove the section from under the car.

**5** To remove the intermediate section, undo the nuts securing the intermediate section to the front and rear sections at the flange joints

and separate the joints. Recover the flange gaskets. Disengage the side rubber mountings and remove the section from under the car.

**6** To remove the front section, undo the nuts securing the front section to the manifold and intermediate section, separate the flange joints and remove the section from under the car. Recover the flange gaskets.

**7** If necessary, the front and rear heat shields

can be removed after removing the relevant exhaust section, then undoing the heat shield retaining bolts.

### Refitting

**8** Refitting is a reversal of removal, but use new gaskets if the originals show any sign of deterioration. Tighten the flange retaining nuts to the specified torque.



# Chapter 4 Part B: Fuel and exhaust systems – Lucas multi-point injection engines

## Contents

Accelerator cable - removal, refitting and adjustment . . . . .	3	Fuel injection system components - removal and refitting . . . . .	12
Accelerator cable and linkage check and lubrication . . .See Chapter 1		Fuel pump - removal and refitting . . . . .	6
Accelerator pedal - removal and refitting . . . . .	4	Fuel system - depressurisation . . . . .	5
Air cleaner assembly - removal and refitting . . . . .	2	Fuel tank - removal, inspection and refitting . . . . .	8
Air cleaner element renewal . . . . .See Chapter 1		General information and precautions . . . . .	1
Catalytic converter - general information and precautions . . . . .See Chapter 4E		Inlet manifold - removal and refitting . . . . .See Chapter 2A	
Exhaust manifold - removal and refitting . . . . .See Chapter 2A		Oxygen sensor . . . . .See Chapter 4E	
Exhaust system - general information and component renewal . . . . .	16	Turbocharger - description and precautions . . . . .	13
Exhaust system check . . . . .See Chapter 1		Turbocharger - examination and renovation . . . . .	15
Fuel filter renewal . . . . .See Chapter 1		Turbocharger - removal and refitting . . . . .	14
Fuel gauge sender unit - removal and refitting . . . . .	7	Underbody fuel/brake line check . . . . .See Chapter 1	
Fuel injection system - general information . . . . .	10	Underbonnet check for fluid leaks and hose condition . . . . .See Chapter 1	
Fuel injection system - testing and adjustment . . . . .	11	Unleaded petrol - general information and usage . . . . .	9

## Degrees of difficulty

<b>Easy</b> , suitable for novice with little experience 	<b>Fairly easy</b> , suitable for beginner with some experience 	<b>Fairly difficult</b> , suitable for competent DIY mechanic 	<b>Difficult</b> , suitable for experienced DIY mechanic 	<b>Very difficult</b> , suitable for expert DIY or professional 
--	---	---	--	---

## Specifications

### General

System type . . . . .	Indirect multi-point injection with microprocessor control
ECU-controlled idle speed:	
Manual transmission models . . . . .	850 to 950 rpm
Automatic transmission models . . . . .	800 to 900 rpm
Base idle speed:	
Manual transmission models . . . . .	725 to 775 rpm
Automatic transmission models . . . . .	675 to 725 rpm
Idle mixture CO content:	
Non-catalyst equipped engines . . . . .	0.5 to 1.5%
Catalyst equipped engines . . . . .	0.25%
Throttle potentiometer voltage . . . . .	315 to 335 mV
Fuel octane rating . . . . .	97 RON leaded or 95 RON unleaded

### Fuel Pump

Type:	
Normally-aspirated engines . . . . .	Nippon Denso, electric
Turbocharged engines . . . . .	AC electric
Output pressure:	
Normally-aspirated engines . . . . .	4.1 bar
Turbocharged engines . . . . .	5.5 bar
Regulated pressure range . . . . .	3.0 to 2.3 bar
Delivery rate (at 3.0 bars and 12 volts):	
Normally-aspirated engines . . . . .	70 litres/hour
Turbocharged engines . . . . .	120 litres/hour

### Turbocharger

Type . . . . .	Garret T25
Wastegate opening pressure . . . . .	0.34 to 0.36 bar

**Torque wrench settings**

	Nm	lbf ft
Fuel filter banjo union bolts	50	37
Brake servo hose banjo union bolt	50	37
Fuel pump banjo union bolt	22	16
Fuel tank drain plug	50	37
Fuel tank strap locknuts	18	13
Exhaust front pipe to manifold	30	22
Exhaust section flange nuts	30	22
Exhaust heat shield retaining bolts	25	18

**1 General information and precautions**

The fuel system used on earlier Rover 820i, Si, SLi and Turbo models consists of a centrally-mounted fuel tank, electric fuel pump and indirect multi-point fuel injection (MPi) system, together with its related electrical and mechanical components. A more detailed description of the MPi system is contained in Section 10.

The exhaust system consists of a front, intermediate and rear section, suspended from the underbody on rubber mountings, and bolted to a cast iron manifold at the front. A ball-and-socket universal joint is incorporated in the front section, to allow for engine and exhaust system movement.

**Precautions**



**Warning:** Many of the procedures in this Chapter require the removal of fuel lines and connections, which may result in some fuel spillage. Petrol is extremely flammable, so take extra precautions when you work on any part of the fuel system. Don't smoke, or allow open flames or bare light bulbs, near the work area. Don't work in a garage where a natural gas-type appliance (such as a water heater or clothes dryer) with a pilot light is present. If you spill any fuel on your skin, rinse it off immediately with soap and water. When you perform any kind of work on the fuel system, wear safety glasses, and have a Class B type fire extinguisher on hand. Before carrying out any operation on the fuel system, refer also to the precautions given in "Safety first!" at the beginning of this manual, and follow them implicitly. Petrol is a highly-dangerous and volatile liquid, and the precautions necessary when handling it cannot be overstressed.

Reference must also be made to Chapter 5, Section 1 for precautionary notes concerning the ignition system and battery disconnection, and to any further safety-related text contained within the appropriate Section, before working on the vehicle.

Certain adjustment points in the fuel system are protected by tamperproof caps, plugs or

seals. In some territories, it is an offence to drive a vehicle with broken or missing tamperproof seals. Before disturbing a tamperproof seal, first check that no local or national laws will be broken by doing so, and fit a new tamperproof seal after adjustment is complete, where required by law. Do not break tamperproof seals on any vehicle whilst it is still under warranty.

When working on fuel system components, scrupulous cleanliness must be observed and care must be taken not to introduce any foreign matter into the fuel lines or components.

**2 Air cleaner assembly - removal and refitting**



**Note:** Air cleaner element renewal is described in Chapter 1.

**Removal**

**Normally-aspirated engines**

- Slacken the hose clip and disconnect the air trunking at the throttle housing (see illustration).
- Disconnect the airflow meter wiring connector, and release the cable from the support clip.
- Undo the two air cleaner body and airflow meter support bracket bolts, and the two bolts securing the forward air trunking to its support bracket (see illustration).
- Withdraw the air cleaner body, complete with airflow meter and forward air trunking,



**2.1 Disconnect the air trunking at the throttle housing**

release the trunking from the connecting duct at the front of the car, and remove the assembly from the engine compartment.

- If the cold air side intake is to be removed, refer to Chapter 5 and remove the battery.
- Undo the bolt securing the side intake to the body, and remove the intake and duct.

**Turbocharged engines**

- Remove the battery as described in Chapter 5, then undo the bolts and lift out the battery tray.
- Undo the wastegate control solenoid valve retaining screw and move the valve aside.
- Disconnect the airflow meter wiring multiplug.
- Undo the three mounting bracket retaining bolts.
- Release the two clips securing the heat shield to the heater pipe and remove the heat shield.
- Slacken the clip securing the air intake hose to the turbocharger and release the hose. Remove the breather hose from the intake hose.
- Disconnect the wiring multiplug from the wastegate control solenoid valve.
- Release the air cleaner assembly from the intake duct and carefully lift out the air cleaner, airflow meter and mounting bracket.
- The remaining intake ducts can now be removed as required.

**Refitting**

- Refitting is a reversal of removal, but ensure that all the ducts and trunking are fully engaged before tightening the various retaining bolts.



**2.3 Forward air trunking to support bracket bolt**

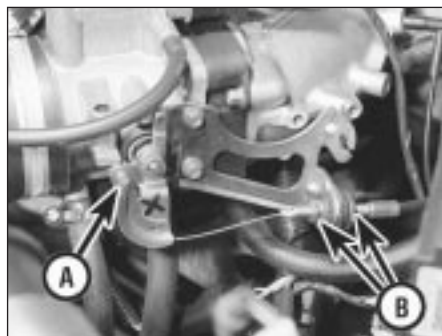

**3.1 Accelerator cable end fitting attachment at the throttle lever (A), and outer cable locknuts (B)**

**3 Accelerator cable - removal, refitting and adjustment**



**Removal**

- 1 Open the throttle fully by hand, and slip the inner cable end out of the slot on the throttle lever (see illustration).
- 2 Slacken the outer cable locknuts, and fully unscrew the outer locknut, nearest to the cable end.
- 3 Remove the washer and rubber bush, then withdraw the cable from the support bracket.
- 4 From inside the car, release the turnbuckles and lift out the trim panel over the clutch, brake and accelerator pedals.
- 5 Prise the retaining clip from the top of the accelerator pedal, and disconnect the inner cable.
- 6 Release the cable from the engine compartment bulkhead, and from the support clips, and withdraw the complete cable from the car.

**Refitting**

- 7 Refitting is a reversal of removal. Adjust the cable initially by means of the outer cable locknuts, to give a small amount of free play with the throttle closed. On completion, check the engine base idle speed as described in Section 11.

**4 Accelerator pedal - removal and refitting**

Refer to Part A, Section 4.

**5 Fuel system - depressurisation**



**Warning: Refer to the precautions contained in Section 1 before proceeding.**

1 The fuel system referred to in this Chapter is defined as the fuel tank and tank-mounted

fuel pump/fuel gauge sender unit, the fuel filter, the fuel pressure regulator, the fuel injectors, and the metal pipes and flexible hoses of the fuel lines between these components. Most of these contain fuel which will be under pressure while the engine is running and/or while the ignition is switched on.

- 2 The pressure will remain for some time after the ignition has been switched off, and must be relieved before any of these components are disturbed for servicing or repair work.
- 3 Disconnect the battery negative (earth) lead (refer to Chapter 5, Section 1).
- 4 Place absorbent rags around the bleed screw in the centre of the fuel filter outlet union banjo bolt, then slowly unscrew the bleed screw to relieve the system pressure.
- 5 Once the pressure has been completely relieved, tighten the bleed screw and dispose of the rags safely.

**6 Fuel pump - removal and refitting**

Refer to Part A, Section 6.

**7 Fuel gauge sender unit - removal and refitting**

Refer to Part A, Section 7.

**8 Fuel tank - removal, inspection and refitting**

Refer to Part A, Section 8.

**9 Unleaded petrol - general information and usage**

Refer to Part A, Section 9.

**10 Fuel injection system - general information**

The multi-point fuel injection (MPI) system is a microprocessor-controlled fuel management system, designed to overcome the limitations associated with conventional carburettor induction. This is achieved by continuously monitoring the engine using various sensors, whose data is input to the fuel system Electronic Control Unit (ECU). Based on this information, the ECU program and memory then determine the exact amount of fuel necessary, which is then injected directly into the inlet manifold, for all actual and anticipated driving conditions.

The main components of the system and their individual operation are as follows (see illustration).

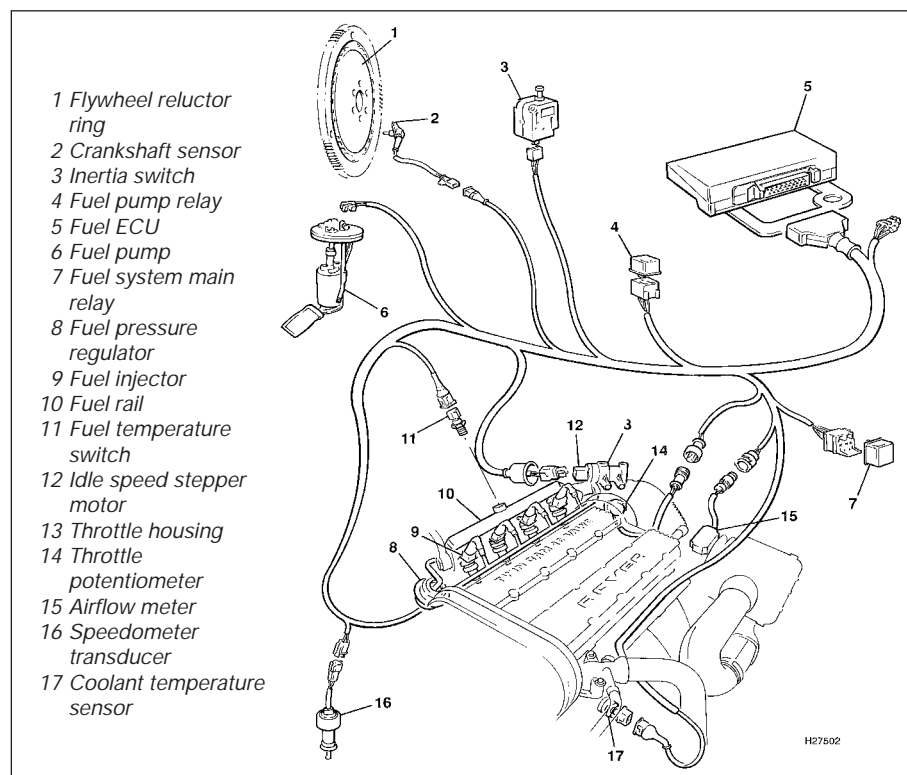

**10.2 Main components of the multi-point fuel injection system**

**Fuel ECU:** The fuel ECU is a microprocessor, which controls the entire operation of the fuel system. Contained in the ECU memory is a program which controls the fuel supply to the injectors, and their opening duration. The program enters sub-routines to alter these parameters, according to inputs from the other components of the system. In addition to this, the engine idle speed is also controlled by the ECU, which uses a stepper motor to open or close an air valve as required.

**Fuel injectors:** Each fuel injector consists of a solenoid-operated needle valve, which opens under commands from the fuel ECU. Fuel from the fuel rail is then delivered through the injector nozzle into the inlet manifold.

**Coolant temperature sensor:** This resistive device is screwed into the thermostat housing, where its element is in direct contact with the engine coolant. Changes in coolant temperature are detected by the ECU as a change in sensor resistance.

**Airflow meter:** This contains two resistive elements mounted in the intake air stream, one of which is heated by a current passing through it. Air passing over the heated wire alters its resistance by cooling it, while the temperature of the air is sensed by the other wire. An electronic module within the airflow meter monitors the reaction of the elements to the airflow, and provides a proportional signal to the ECU.

**Throttle potentiometer:** The potentiometer is a variable resistor, attached to the throttle shaft in the throttle housing. The unit is supplied with a constant input voltage, and as the resistance of the potentiometer varies with throttle shaft movement, the output voltage is proportionally affected. This allows the fuel ECU to determine throttle valve position, and rate of change.

**Idle speed stepper motor:** This is a small electric motor, having two control windings to enable it to rotate in either direction. Under a signal from the fuel ECU, the stepper motor will rotate in whichever direction is necessary, to open or close the air valve in the throttle housing. This allows air to bypass the throttle valve and maintain a stabilised idling speed.

**Fuel pump:** The fuel pump is a self-priming centrifugal unit, located in the fuel tank, and totally submerged in the fuel. Fuel is supplied under pressure from the pump, through an in-line filter, to the fuel rail and fuel pressure regulator.

**Fuel pressure regulator:** The regulator is a vacuum-operated mechanical device, which ensures that the pressure differential between fuel in the fuel rail and fuel in the inlet manifold is maintained at a constant value. As manifold depression increases, the regulated fuel pressure is reduced in direct proportion. When fuel pressure in the fuel rail exceeds the regulator setting, the regulator opens to allow fuel to return via the return line to the tank.

**Relays:** The main relay is energised when the ignition is switched on, and provides the fuel ECU supply voltage. The fuel relay is

energised by the fuel ECU for a short period after the ignition is initially switched on, and then continuously when the engine is running.

**Fuel temperature switch:** The fuel temperature switch contacts remain open during normal engine operation, and only closes when the temperature of the fuel in the fuel rail exceeds a preset value. When the contacts close, a signal is sent to the fuel ECU, overriding the coolant thermistor signal. The ECU then alters the opening duration of the injectors accordingly, to minimise the effects of fuel vaporisation.

**Inertia switch:** The switch is a mechanically-controlled accelerator, connected in the electrical circuit between the ignition switch and the fuel ECU and fuel relay. Under violent deceleration or impact, the switch trips out, and cuts off the supply voltage. Depressing a button on the switch body resets the switch.

### 11 Fuel injection system - testing and adjustment



#### Testing

**1** If a fault appears in the fuel injection system, first ensure that all the system wiring connectors are securely connected and free of corrosion. Then ensure that the fault is not due to poor maintenance; ie, check that the air cleaner filter element is clean, the spark plugs are in good condition and correctly gapped, the cylinder compression pressures are correct, and that the engine breather hoses are clear and undamaged, referring to the relevant Sections of this Chapter, and to Chapters 1 and 2 for further information.

**2** If these checks fail to reveal the cause of the problem, the vehicle should be taken to a suitably equipped Rover dealer for testing on Rover dedicated test equipment. This equipment will locate the fault quickly and simply, alleviating the need to test all the system components individually, which is a time-consuming operation that carries an element of risk of damaging the ECU.

#### Adjustment

##### Engine tuning procedure

**3** Before making any changes to the settings of the fuel injection system, ensure that the spark plug gaps are correctly set, the air cleaner element is clean, there are no leaks in the exhaust system, and the ignition system is operating correctly. Ensure that all breather and vacuum hoses are connected, and that none are perished or kinked.

**4** Check that there is at least 5.0 mm of free play in the accelerator cable, and that the throttle lever rests against its stop in the released condition. Adjust the cable as described in Section 3 if necessary.

**5** Temperature effects, and engine and transmission oil drag, can adversely influence

the idle speed and mixture settings, and it is important that the following warm-up procedure is adopted before attempting any adjustments.

**6** Drive the car on the road for approximately two to four miles, dependent on summer or winter conditions, in a normal manner, without excessive load, engine speed or road speed.

**7** Return the car to the working area, and without switching off the engine, connect an exhaust gas analyser (CO meter) in accordance with the equipment manufacturer's instructions. The analyser should be warmed up, correctly calibrated and ready for immediate use. Commence the adjustment procedure described below immediately.

**8** If, during the adjustment procedure, the cooling fan operates, or if adjustment is not completed within two minutes, accelerate the engine to 2000 rpm, and hold this speed for ten seconds. Repeat this every two minutes until the adjustments are completed.

#### Base idle speed and mixture adjustment

**Note:** On models equipped with a catalytic converter, all adjustments should be entrusted to a Rover dealer. Any maladjustment of the system settings could have an adverse effect on the operation of the emission control equipment.

**9** The fuel injection system is such that the engine idle speed and mixture settings are controlled by the fuel ECU. Unless a new component has been fitted, the idle speed or mixture screws have been tampered with, or the idle quality is unsatisfactory, no adjustment should be necessary. If, however, the settings are to be altered, an accurate exhaust gas analyser (CO meter), tachometer, and voltmeter will be required.

**10** Refer to the engine tuning procedure information contained above before starting.

**11** Switch off all electrical accessories, and ensure that they remain switched off throughout the adjustment procedure.

**12** With the engine idling and the exhaust gas analyser connected, take a reading of the exhaust gas CO content. If this is not as given in the Specifications, hook out the tamperproof plug over the idle mixture adjustment screw, and turn the screw clockwise to enrich the mixture, or anti-clockwise to weaken it as necessary (see illustration).

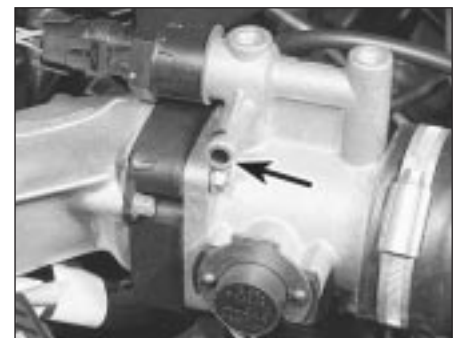

11.12 Idle mixture adjustment screw tamperproof plug (arrowed)





11.14 Disconnect the stepper motor wiring multiplug

13 With the CO content correctly adjusted, switch off the engine and connect a tachometer according to the manufacturer's instructions.

14 Before adjusting the base idle speed, the stepper motor must be cycled to its fully-extended position, using the following procedure:

- (a) Switch on the ignition.
- (b) Disconnect the stepper motor wiring multiplug on the top of the throttle housing (see illustration).
- (c) Switch off the ignition, wait five seconds, and reconnect the stepper motor multiplug.
- (d) Switch on the ignition, wait five seconds, and disconnect the stepper motor multiplug again.
- (e) Switch off the ignition, wait five seconds, and reconnect the stepper motor multiplug.
- (f) Switch on the ignition, wait five seconds, and disconnect the stepper motor multiplug once more. The stepper motor is now fully extended.

15 Start the engine, and allow it to idle until normal operating temperature is again reached.

16 Check the reading on the tachometer, and compare this with the base idle speed figure given in the Specifications.

17 If adjustment is necessary, hook out the tamperproof plug over the idle speed adjusting screw, and turn the adjusting screw as necessary to achieve the correct setting (see illustration).

18 Increase the engine speed to 2000 rpm for ten seconds, then return it to idle.

19 Recheck the exhaust CO content, as described earlier in this Section.

20 Switch off the ignition, and pull back the dust cover over the throttle potentiometer wiring multiplug.

21 Insert the probes from the voltmeter into the back of the multiplug so that the voltmeter black lead is connected to the pink/black wire, and the red lead is connected to the light green/pink wire.

22 Select millivolts on the voltmeter, then switch on the ignition.

23 Check that the reading on the voltmeter



11.17 Base idle speed adjusting screw tamperproof plug (arrowed)

scale is now equal to the throttle potentiometer voltage, as given in the Specifications. If this is not the case, slacken the two retaining screws, and slowly move the potentiometer body until the correct reading is obtained (see illustration). Tighten the screws securely.

24 Open and close the throttle several times, then with it closed, check the voltmeter reading once more. Repeat the adjustment if the reading is now outside the specified tolerance.

25 With the adjustments complete, switch off the engine and disconnect the test instruments.

## 12 Fuel injection system components - removal and refitting



**Note:** Refer to the precautions contained in Section 1 before proceeding.

### Airflow meter - normally-aspirated engines

#### Removal

1 Slacken the hose clip and detach the air trunking from the airflow meter (see illustration).

2 Release the airflow meter wiring harness

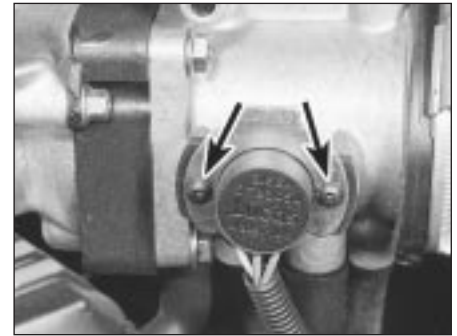

11.23 Throttle potentiometer retaining screws (arrowed)

from its retaining clip, and disconnect the wiring multiplug.

3 Undo the two bolts securing the unit to its mounting bracket, withdraw the unit from the air cleaner body, and recover the seal.

#### Refitting

4 Refitting is a reversal of removal.

### Airflow meter - turbocharged engines

#### Removal

5 Remove the air cleaner and airflow meter assembly as described in Section 2.

6 Slacken the clip and disconnect the turbocharger intake hose from the airflow meter.

7 Undo the four bolts and three nuts and separate the airflow meter from the air cleaner and bracket assembly.

#### Refitting

8 Refitting is a reversal of removal.

### Idle speed stepper motor

#### Removal

9 Slide back the rubber dust cover (where fitted), and disconnect the stepper motor wiring multiplug.

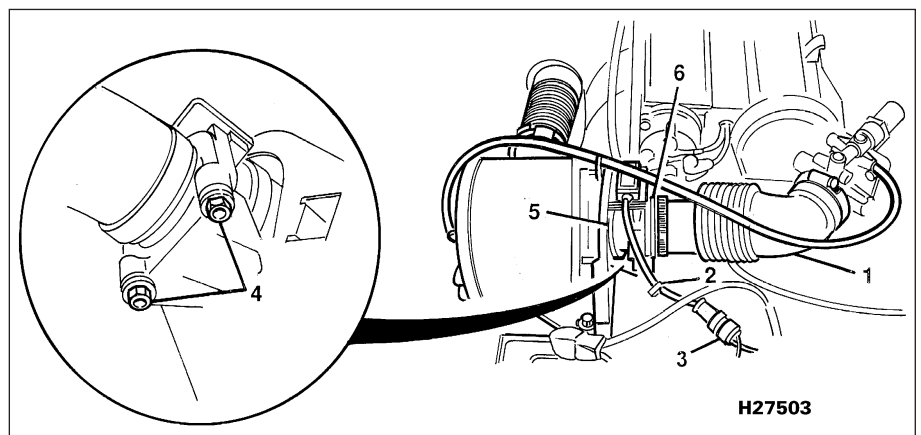

12.1 Airflow meter attachments

- |                                 |                    |                 |
|---------------------------------|--------------------|-----------------|
| 1 Air trunking                  | 3 Wiring multiplug | 5 Airflow meter |
| 2 Wiring harness retaining clip | 4 Retaining bolts  | 6 Seal location |

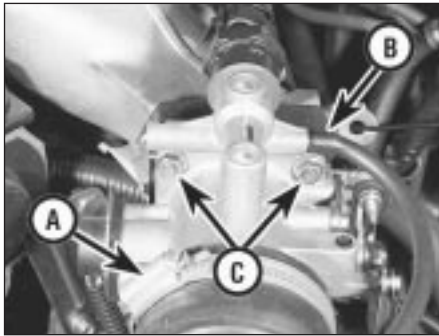

12.18 Air intake trunking retaining clip (A), air valve hose (B), and throttle housing upper retaining nuts (C)

10 Using a 32 mm spanner, unscrew the stepper motor from the throttle housing.

### Refitting

11 Refitting is a reversal of removal.

### Throttle potentiometer

#### Removal

12 Disconnect the throttle potentiometer wiring harness multiplug.

13 Using a dab of paint, mark the position of the potentiometer in relation to the throttle housing, so that if the original unit is refitted, its position can be restored.

14 Undo the two screws, remove the unit from the throttle housing, and recover the gasket (see illustration 11.23).

#### Refitting

15 Refit the potentiometer and gasket, align the previously-made mark, then tighten the two retaining screws. If a new unit is being fitted, position it centrally within its adjustment range.

16 Adjust the base idle speed and mixture settings as described in Section 11.

### Throttle housing

#### Removal

17 Drain the cooling system as described in Chapter 1.

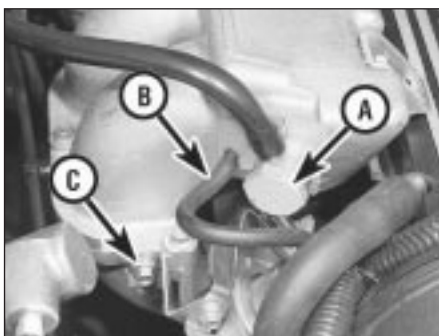

12.37 Brake servo vacuum hose banjo union (A), additional vacuum hose (B), and fuel pressure regulator mounting bracket bolt (C)



12.30 Fuel temperature switch wiring multiplug

18 Slacken the hose clip and detach the air intake trunking from the throttle housing (see illustration).

19 Disconnect the throttle potentiometer and stepper motor wiring multiplugs.

20 Disconnect the air valve hose from the top of the housing, and the breather hose from below.

21 Slacken the clips and disconnect the two coolant hoses from the housing.

22 Open the throttle fully by hand, and slip the accelerator inner cable end out of the slot on the throttle lever.

23 Slacken the outer cable locknuts, and unscrew the outer locknut, nearest to the cable end, fully.

24 Remove the washer and rubber bush, then withdraw the accelerator cable from the support bracket.

25 On automatic transmission models, disconnect the kickdown cable using the same procedure as for the accelerator cable.

26 Undo the four retaining nuts and remove the throttle housing from its mounting.

27 If further dismantling is required, the stepper motor and throttle potentiometer can be removed, as described earlier in this Section.

#### Refitting

28 Refitting is a reversal of removal. Refill the cooling system as described in Chapter 1 and, on automatic transmission models,



12.39 Plenum chamber mounting bracket to camshaft cover bolt (arrowed)



12.36 Vacuum hose connections at the throttle housing end of the plenum chamber

adjust the kickdown cable as described in Chapter 7, Part B. Adjust the base idle speed and mixture settings as described in Section 11 on completion.

### Fuel temperature switch

#### Removal

29 Disconnect the battery negative (earth) lead (refer to Chapter 5, Section 1).

30 Disconnect the wiring multiplug from the temperature switch, located in the centre of the fuel rail behind the plenum chamber (see illustration).

31 Unscrew the switch and remove it from the fuel rail.

#### Refitting

32 Refitting is a reversal of removal.

### Plenum chamber

#### Removal

33 Disconnect the battery negative (earth) lead (refer to Chapter 5, Section 1).

34 Slacken the hose clip and detach the air intake trunking from the throttle housing.

35 Undo the four nuts securing the throttle housing to the plenum chamber, ease the housing off the studs, and move it slightly to one side.

36 Disconnect the two vacuum hoses at the throttle housing end of the plenum chamber (see illustration).

37 At the other end of the plenum chamber, unscrew the brake servo vacuum hose banjo union bolt, disconnect the vacuum hose adjacent to the banjo union, and undo the fuel pressure regulator mounting bracket bolt (see illustration). Recover the two copper washers from the banjo union, and note that the hose locates between two locating pegs in its fitted position.

38 Remove the fuel temperature switch as described previously.

39 Undo the two bolts securing the plenum chamber mounting brackets to the camshaft cover (see illustration).

40 Undo the six bolts securing the rear of the



12.40 Plenum chamber to inlet manifold retaining bolt locations

plenum chamber to the inlet manifold (see illustration).

41 Lift the plenum chamber off the manifold, and recover the four locating sleeves and O-ring seals.

42 Clean the manifold and plenum chamber mating faces, and renew the O-ring seals if they show any sign of deterioration.

**Refitting**

43 Refitting is a reversal of removal. Fit the locating sleeves to the manifold before the O-ring seals, and tighten all nuts and bolts securely.

**Fuel pressure regulator**

**Removal**

44 Disconnect the battery negative (earth) lead (refer to Chapter 5, Section 1).

45 Relieve the fuel system pressure as described in Section 5.

46 Detach the breather hose from the camshaft cover, and move the hose aside (see illustration).

47 Disconnect the vacuum hose from the top of the regulator (see illustration).

48 Unscrew the fuel return hose union from the base of the regulator.

49 Undo the regulator bracket retaining bolts, and withdraw the regulator from the fuel rail.

**Refitting**

50 Refitting is a reversal of removal.

**Fuel injectors**

**Removal**

51 Disconnect the battery negative (earth) lead (refer to Chapter 5, Section 1).

52 Relieve the fuel system pressure as described in Section 5.

53 Remove the plenum chamber and fuel temperature switch as described previously.

54 Detach the breather hose from the camshaft cover, and move the hose aside.

55 Disconnect the fuel pressure regulator vacuum hose.

56 Undo the fuel pressure regulator mounting bracket bolts.

57 Undo the union nut, and disconnect the fuel supply hose from the fuel rail.



12.46 Detach the breather hose from the camshaft cover

58 Undo the union nut, and disconnect the fuel return hose from the fuel pressure regulator.

59 Disconnect the multiplugs from each of the four injectors (see illustration).

60 Undo the two bolts securing the fuel rail to the inlet manifold.

61 Ease the four injectors out of their inlet manifold locations, and lift up the injector and fuel rail assembly. Recover the O-ring seal from each injector outlet.

62 Extract the retaining clips, and remove the injectors from the fuel rail. Recover the O-ring seal from each injector inlet.

**Refitting**

63 Refitting is a reversal of removal, but renew the injector inlet and outlet O-rings.

**Electronic control unit (ECU)**

**Removal**

64 Disconnect the battery negative (earth) lead (refer to Chapter 5, Section 1).

65 Slide the driver's seat fully forwards.

66 From under the driver's seat, undo the two screws and lift off the ECU cover.

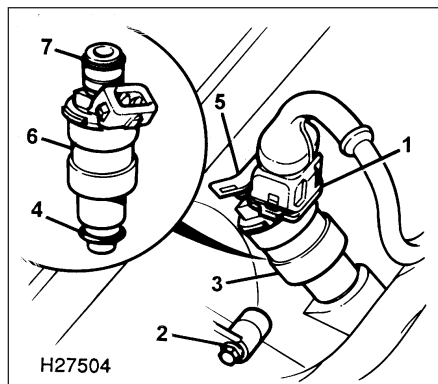

12.59 Fuel injector and fuel rail details

- 1 Injector multiplug
- 2 Fuel rail retaining bolt
- 3 Fuel injector location on inlet manifold
- 4 Injector outlet O-ring seal
- 5 Injector to fuel rail retaining clip
- 6 Injector body
- 7 Injector inlet O-ring seal

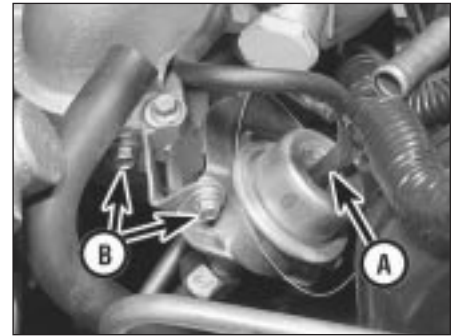

12.47 Fuel pressure regulator vacuum hose (A) and mounting bracket bolts (B)

67 Undo the bolt securing the rear of the mounting bracket to the floor (see illustration).

68 Slide the driver's seat fully rearwards, and undo the two bolts securing the front of the mounting bracket to the floor.

69 Withdraw the ECU and mounting bracket assembly from under the seat.

70 Depress the multiplug retaining tab, and pull the plug straight from the socket.

71 Remove the ECU from the car.

**Refitting**

72 Refitting is a reversal of removal.

**Resonator unit**

Refer to Part A, Section 12.

**Inertia switch**

Refer to Part A, Section 12.

**13 Turbocharger - description and precautions**

**Description**

1 On turbocharged engines, the turbocharger increases engine efficiency by raising the pressure in the inlet manifold above atmospheric pressure. Instead of the air simply being sucked into the cylinders, it is forced in.

2 Energy for the operation of the turbocharger comes from the exhaust gas.

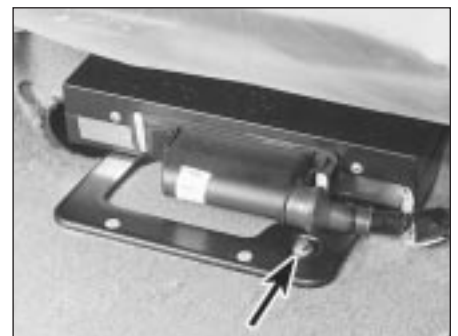

12.67 ECU mounting bracket retaining bolt (arrowed)

The gas flows through a specially-shaped housing (the turbine housing) and in so doing, spins the turbine wheel. The turbine wheel is attached to a shaft, at the end of which is another vaned wheel known as the compressor wheel. The compressor wheel spins in its own housing, and compresses the inlet air on the way to the inlet manifold.

**3** Boost pressure (the pressure in the inlet manifold) is limited by a wastegate, which diverts the exhaust gas away from the turbine wheel in response to a pressure-sensitive actuator.

**4** The turbo shaft is pressure-lubricated by an oil feed pipe from the main oil gallery. The shaft "floats" on a cushion of oil. A drain pipe returns the oil to the sump.

### Precautions

**5** The turbocharger operates at extremely high speeds and temperatures. Certain precautions must be observed, to avoid premature failure of the turbo, or injury to the operator.

**6** Do not operate the turbo with any of its parts exposed, or with any of its hoses removed. Foreign objects falling onto the rotating vanes could cause excessive damage, and (if ejected) personal injury.

**7** Do not race the engine immediately after start-up, especially if it is cold. Give the oil a few seconds to circulate.

**8** Always allow the engine to return to idle speed before switching it off - do not blip the throttle and switch off, as this will leave the turbo spinning without lubrication.

**9** Allow the engine to idle for several minutes before switching off after a high-speed run.

**10** Observe the recommended intervals for oil and filter changing, and use a reputable oil of the specified quality. Neglect of oil changing, or use of inferior oil, can cause carbon formation on the turbo shaft, leading to subsequent failure.

## 14 Turbocharger - removal and refitting

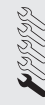

### Removal

**1** Disconnect the battery negative (earth) lead (refer to Chapter 5, Section 1).

**2** Drain the cooling system as described in Chapter 1.

**3** Remove the air cleaner complete with airflow meter assembly as described in Section 2.

**4** Undo the bolts and remove the heat shield behind the alternator.

**5** Slacken the two clips and remove the oil return hose at the base of the turbocharger.

**6** Slacken the two hose clips and remove air the outlet hose from the turbocharger.

**7** Disconnect the vacuum hose at the wastegate solenoid valve.

**8** Disconnect the oil feed pipe unions at the turbocharger.

**9** Disconnect the coolant feed and return hoses at the turbocharger and engine pipe outlets.

**10** Remove the engine oil dipstick and release the dipstick tube from its upper attachments.

**11** Release the hose clips and support brackets and remove the coolant pipe over the top of the exhaust manifold.

**12** Disconnect the wiring multiplug connector above the alternator and release the cable harness from its clips.

**13** Disconnect the wastegate control solenoid wiring.

**14** Undo the three nuts and separate the exhaust downpipe from the turbocharger outlet flange.

**15** Undo the exhaust manifold retaining nuts and withdraw the manifold complete with

turbocharger assembly off the studs. Recover the manifold gasket.

**16** Undo the nuts securing the turbocharger to the exhaust manifold and remove the turbocharger. Recover the flange gasket.

**17** Thoroughly clean all the joint mating faces prior to refitting.

### Refitting

**18** Refitting is a reversal of removal, but use new gaskets at all the flange joints. Refill the cooling system and top-up the engine oil as described in Chapter 1 on completion.

## 15 Turbocharger - examination and renovation



**1** With the turbocharger removed, inspect the housing for cracks or other visible damage.

**2** Spin the turbine or the compressor wheel, to verify that the shaft is intact and to feel for excessive shake or roughness. Some play is normal, since in use, the shaft is "floating" on a film of oil. Check that the wheel vanes are undamaged.

**3** If the exhaust or induction passages are oil-contaminated, the turbo shaft oil seals have probably failed.

**4** No DIY repair of the turbo is possible. A new unit may be available on an exchange basis.

## 16 Exhaust system - general information and component renewal

Refer to Part A, Section 13 and, on vehicles equipped with a catalytic converter, to Part E, Section 3.



# Chapter 4 Part C: Fuel and exhaust systems – MEMS multi-point injection engines

## Contents

Accelerator cable - removal, refitting and adjustment . . . . .	3	Fuel injection system components - removal and refitting . . . . .	12
Accelerator cable and linkage check and lubrication . . . . .	See Chapter 1	Fuel pump - removal and refitting . . . . .	6
Accelerator pedal - removal and refitting . . . . .	4	Fuel system - depressurisation . . . . .	5
Air cleaner assembly - removal and refitting . . . . .	2	Fuel tank - removal, inspection and refitting . . . . .	8
Air cleaner element renewal . . . . .	See Chapter 1	General information and precautions . . . . .	1
Catalytic converter - general information and precautions . . . . .	See Chapter 4E	Inlet manifold - removal and refitting . . . . .	See Chapter 2A
Exhaust manifold - removal and refitting . . . . .	See Chapter 2A	Intercooler - removal and refitting . . . . .	16
Exhaust system - general information and component renewal . . . . .	17	Oxygen sensor . . . . .	See Chapter 4E
Exhaust system check . . . . .	See Chapter 1	Turbocharger - description and precautions . . . . .	13
Fuel filter renewal . . . . .	See Chapter 1	Turbocharger - examination and renovation . . . . .	15
Fuel gauge sender unit - removal and refitting . . . . .	7	Turbocharger - removal and refitting . . . . .	14
Fuel injection system - general information . . . . .	10	Underbody fuel/brake line check . . . . .	See Chapter 1
Fuel injection system - testing and adjustment . . . . .	11	Underbonnet check for fluid leaks and hose condition . . . . .	See Chapter 1
		Unleaded petrol - general information and usage . . . . .	9

## Degrees of difficulty

<b>Easy</b> , suitable for novice with little experience 	<b>Fairly easy</b> , suitable for beginner with some experience 	<b>Fairly difficult</b> , suitable for competent DIY mechanic 	<b>Difficult</b> , suitable for experienced DIY mechanic 	<b>Very difficult</b> , suitable for expert DIY or professional 
---	--	--	---	--

## Specifications

### General

System type . . . . .	Modular Engine Management System (MEMS) with indirect multi-point injection
ECU-controlled idle speed:	
Normally-aspirated engines . . . . .	825 to 925 rpm
Pre-1994 turbocharged engines . . . . .	825 to 925 rpm
1994-on turbocharged engines . . . . .	775 to 875 rpm
Fuel octane rating . . . . .	95 RON unleaded only

### Fuel Pump

Type . . . . .	AC electric
Output pressure:	
Normally-aspirated engines . . . . .	3.2 bar
Turbocharged engines . . . . .	4.3 bar
Regulated pressure range . . . . .	2.8 to 3.2 bar
Delivery rate (at 3.0 bar and 12 volts):	
Normally-aspirated engines . . . . .	64 litres/hour
Turbocharged engines . . . . .	73 litres/hour

### Turbocharger

Type . . . . .	Garret T25
Wastegate opening pressure . . . . .	0.43 bar

Torque wrench settings	Nm	lbf ft
Fuel filter banjo union bolts	38	28
Fuel pressure regulator retaining bolts	10	7
Brake servo hose banjo union bolt	50	37
Plenum chamber to inlet manifold	10	7
Fuel rail to inlet manifold	10	7
Fuel pump banjo union bolt	22	16
Fuel tank drain plug	50	37
Fuel tank strap locknuts	22	16
Fuel temperature sensor	15	11
Turbocharger to exhaust manifold	30	22
Turbocharger exhaust elbow bolts	25	18
Turbocharger to exhaust front pipe	10	7
Exhaust front pipe to manifold	30	22
Exhaust section flange nuts	30	22
Exhaust heat shield retaining bolts	25	18

## 1 General information and precautions

The fuel system used on later Rover 820i, Si, SLi and Vitesse models consists of a centrally-mounted fuel tank, electric fuel pump and indirect multi-point fuel injection, as part of the Modular Engine Management System (MEMS). A more detailed description of the system is contained in Section 10.

The exhaust system consists of a front, intermediate and rear section, suspended from the underbody on rubber mountings, and bolted to a cast iron manifold at the front. A catalytic converter is fitted between the front and intermediate sections and a flexible joint is also incorporated in the front section, to allow for engine and exhaust system movement.

### Precautions



**Warning:** Many of the procedures in this Chapter require the removal of fuel lines and connections, which may result in some fuel spillage. Petrol is extremely flammable, so take extra precautions when you work on any part of the fuel system. Don't smoke, or allow open flames or bare light bulbs, near the work area. Don't work in a garage where a natural gas-type appliance (such as a water heater or clothes dryer) with a pilot light is present. If you spill any fuel on your skin, rinse it off immediately with soap and water. When you perform any kind of work on the fuel system, wear safety glasses, and have a Class B type fire extinguisher on hand. Before carrying out any operation on the fuel system, refer also to the precautions given in "Safety first!" at the beginning of this manual, and follow them implicitly. Petrol is a highly-dangerous and volatile liquid, and the precautions necessary when handling it cannot be overstressed.

Reference must also be made to Chapter 5, Section 1 for precautionary notes concerning the ignition system and battery disconnection,

and to any further safety-related text contained within the appropriate Section, before working on the vehicle.

Certain adjustment points in the fuel system are protected by tamperproof caps, plugs or seals. In some territories, it is an offence to drive a vehicle with broken or missing tamperproof seals. Before disturbing a tamperproof seal, first check that no local or national laws will be broken by doing so, and fit a new tamperproof seal after adjustment is complete, where required by law. Do not break tamperproof seals on any vehicle whilst it is still under warranty.

When working on fuel system components, scrupulous cleanliness must be observed and care must be taken not to introduce any foreign matter into the fuel lines or components.

## 2 Air cleaner assembly - removal and refitting

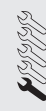

**Note:** Air cleaner element renewal is described in Chapter 1.

### Removal

#### Normally-aspirated engines

- 1 Remove the battery as described in Chapter 5.
- 2 Slacken the hose clip and disconnect the air intake hose between the throttle housing and air cleaner at the air cleaner end.
- 3 Undo the two bolts securing the air cleaner assembly to the mounting bracket.
- 4 Disengage the peg at the base of the air cleaner, release the unit from the intake ducts and remove it from the engine compartment.
- 5 The remaining intake ducts can now be removed as required.

#### Turbocharged engines

- 6 Slacken the clip and release the air intake hose on the side of the air cleaner body.
- 7 Slacken the clip and release the boost control solenoid valve hose from its connection next to the air intake hose.
- 8 Undo the two bolts on the side of the air

cleaner body and remove the unit from the engine compartment.

9 The remaining intake ducts can now be removed as required.

### Refitting

10 Refitting is a reversal of removal, but ensure that all the ducts and trunking are fully engaged before tightening the various retaining bolts.

## 3 Accelerator cable - removal, refitting and adjustment



### Removal

- 1 Open the throttle fully by hand, and slip the inner cable end out of the slot on the throttle lever.
- 2 Unclip the square nut and release the cable from the support bracket.
- 3 Release the cable from the support clip in the engine compartment.
- 4 From inside the car, release the turnbuckles and lift out the trim panel over the clutch, brake and accelerator pedals.
- 5 Prise the retaining clip from the top of the accelerator pedal, and disconnect the inner cable.
- 6 Release the cable from the engine compartment bulkhead by turning the retainer through 90° and withdraw the cable from the car.

### Refitting and adjustment

#### Models up to VIN 152206

- 7 Refit the cable at the pedal end using a reversal of removal.
- 8 At the throttle housing end, screw the square adjusting nut fully onto the threaded portion of the outer cable.
- 9 Connect the inner cable to the throttle lever, and locate the outer cable in the slot in the support bracket.
- 10 Hold the throttle closed then pull the outer cable away from the throttle lever until all slack and lost motion are taken up.

11 Keeping the cable in this position, screw the square nut along the threaded portion of the outer cable until it just touches the support bracket.

12 Without moving the square nut, clip it into its slot in the support bracket.

**Models from VIN 152206**

13 Switch the ignition on, wait five seconds then switch it off again. This will move the stepper motor to the adjustment position.

14 Refit the cable at the pedal end using a reversal of removal.

15 At the throttle housing end, screw the square adjusting nut fully onto the threaded portion of the outer cable.

16 Connect the inner cable to the throttle lever, and locate the outer cable in the slot in the support bracket.

17 Hold the throttle lever closed and check that the throttle position screw is in contact with the stepper motor pin.

18 Pull the outer cable away from the throttle lever until all slack and lost motion are taken up.

19 Keeping the cable in this position, screw the square nut along the threaded portion of the outer cable until it just touches the support bracket.

20 Without moving the square nut, clip it into its slot in the support bracket.

**4 Accelerator pedal - removal and refitting**

Refer to Part A, Section 4, but note that the accelerator pedal switch is only fitted to certain models.

**5 Fuel system - depressurisation**

**Note:** Refer to the precautions contained in Section 1 before proceeding.

Refer to Part B, Section 5.

**6 Fuel pump - removal and refitting**

**Note:** Refer to the precautions contained in Section 1 before proceeding.

Refer to Part A, Section 6.

**7 Fuel gauge sender unit - removal and refitting**

**Note:** Refer to the precautions contained in Section 1 before proceeding.

Refer to Part A, Section 7.

**8 Fuel tank - removal, inspection and refitting**

**Note:** Refer to the precautions contained in Section 1 before proceeding.

Refer to Part A, Section 8.

**9 Unleaded petrol - general information and usage**

Refer to Part A, Section 9.

**10 Fuel injection system - general information**

The Modular Engine Management System (MEMS) is used on later models equipped with the "T" series 4-cylinder engine. It controls a multi-point fuel injection system, an emissions control system and a programmed ignition system as a total engine management package (see illustration).

One Electronic Control Unit (ECU) controls

all the fuelling, emission and ignition requirements of the engine. The ECU incorporates short circuit protection and can also store information on certain intermittent faults for interrogation by computerised test equipment.

The ECU utilises a speed/density method of airflow measurement to calculate fuel delivery. This method, using the engine as a pre-calibrated vacuum pump, with its characteristics stored in the ECU, measures the air inlet temperature and inlet manifold pressure, allowing the correct amount of fuel per air density/speed to be injected.

Should certain elements of the system fail, the ECU can implement a back-up facility, allowing the system to operate at a reduced level of performance until the fault can be rectified.

A diagnostic socket allows tuning or fault diagnosis to be carried out on test equipment without disconnecting the ECU wiring harness.

On early versions of the system, an accelerator pedal switch triggers the ECU between the main fuelling map when the switch is open (accelerator pedal depressed) and idle speed control when the switch is closed (pedal released). The pedal switch also

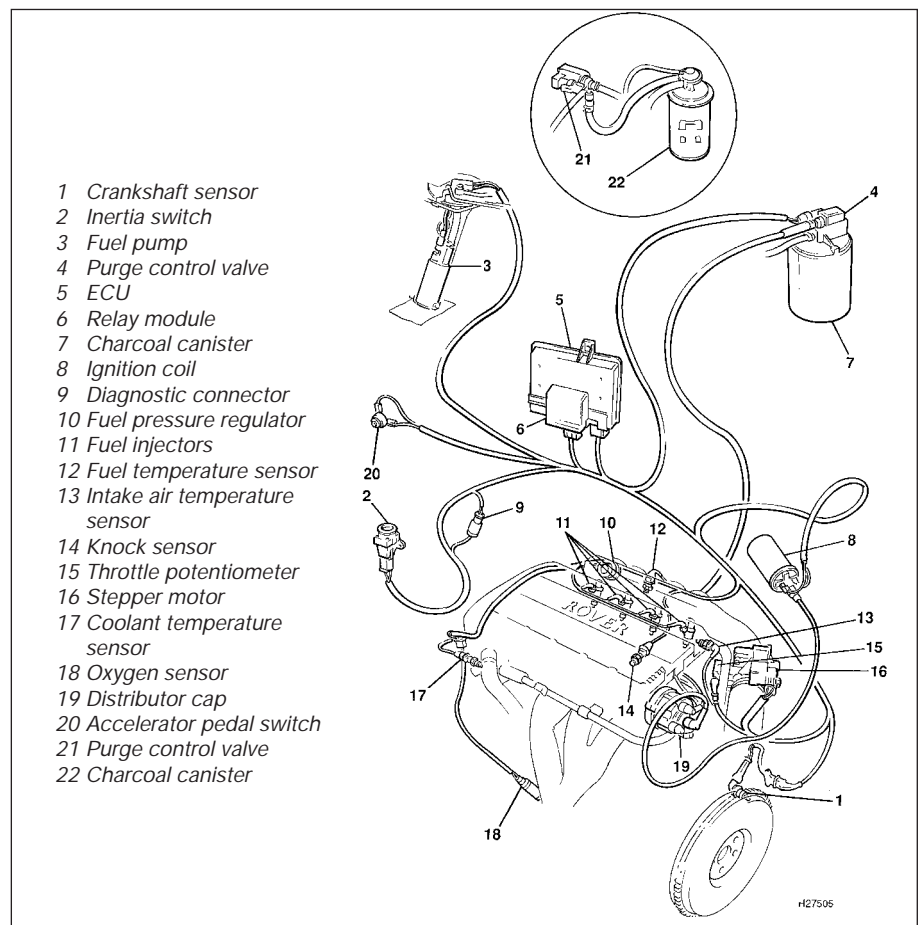

10.1 Main components of the MEMS multi-point fuel injection system

controls an over-run fuel cut-off function. On later versions of the system, the manifold absolute pressure sensor is used to perform the functions of the pedal switch.

The ECU, in determining optimum ignition timing, receives information from the crankshaft sensor (engine speed and crankshaft position), manifold absolute pressure sensor (engine load), knock sensor (detonation), coolant temperature sensor (engine temperature) and where fitted, from the accelerator pedal switch (pedal position), to determine main fuelling or idle speed control.

It can be seen that the system is similar to the earlier fuel injection system described in Part B of this Chapter, the main differences being the method of determining airflow (there is no airflow meter) and the combining of the fuel and ignition ECUs into one unit.

### 11 Fuel injection system - testing and adjustment



#### Testing

1 If a fault appears in the fuel injection system, first ensure that all the system wiring connectors are securely connected and free of corrosion. Then ensure that the fault is not due to poor maintenance; ie, check that the air cleaner filter element is clean, the spark plugs are in good condition and correctly gapped, the cylinder compression pressures are correct, and that the engine breather hoses are clear and undamaged, referring to the relevant Sections of this Chapter, and to Chapters 1 and 2 for further information.

2 If these checks fail to reveal the cause of the problem, the vehicle should be taken to a suitably equipped Rover dealer for testing on Rover dedicated test equipment. This equipment will locate the fault quickly and simply, alleviating the need to test all the

system components individually, which is a time-consuming operation that carries an element of risk of damaging the ECU.

#### Adjustment

3 As all the fuelling and ignition requirements are performed entirely by the electronic control unit, no adjustments to the system are possible. Any irregularities in idling speed stability or engine performance may indicate a fault in the system and should be referred to a dealer for diagnosis and rectification.

### 12 Fuel injection system components - removal and refitting



**Note:** Refer to the precautions contained in Section 1 before proceeding.

#### Intake air temperature sensor

##### Removal

1 Disconnect the wiring multiplug from the temperature sensor located on the inlet manifold.

2 Unscrew the sensor and remove it from the manifold.

##### Refitting

3 Refitting is a reversal of removal.

#### Throttle housing

##### Removal

4 Disconnect the wiring multiplugs from the stepper motor and throttle potentiometer (see illustration).

5 Slacken the clip and detach the air intake hose from the throttle housing.

6 Disconnect the accelerator cable from the throttle lever and support bracket as described in Section 3.

7 On automatic transmission models, disconnect the kick-down cable from the throttle lever and support bracket referring to Chapter 7, Part B if necessary.

8 Release the clips and disconnect the breather hoses.

9 Unscrew the four nuts securing the throttle housing to the inlet manifold and remove the throttle housing.

#### Refitting

10 Refitting is a reversal of removal. Reconnect and adjust the accelerator cable as described in Section 3, and on automatic transmission models, the kick-down cable as described in Chapter 7, Part B.

#### Throttle potentiometer

**Note:** If the potentiometer is being renewed, it will be necessary to have the new unit adjusted by a Rover dealer on completion.

##### Removal

11 Remove the throttle housing as described previously.

12 Using a dab of paint, mark the position of the potentiometer in relation to the throttle housing, so that if the original unit is refitted, its position can be restored.

13 Undo the two screws, remove the unit from the throttle housing, and recover the gasket.

##### Refitting

14 Refit the potentiometer and gasket, align the previously-made mark, then tighten the two retaining screws.

15 If a new unit is being fitted, position it centrally within its adjustment range.

16 Refit the throttle housing as described previously.

17 Have the potentiometer adjusted by a Rover dealer if a new unit was fitted.

#### Accelerator pedal switch

18 Refer to Part A, Section 4.

#### Fuel temperature sensor

##### Removal

19 Disconnect the wiring multiplug from the temperature sensor located on the fuel rail.

20 Unscrew the sensor, remove it from the fuel rail and recover the sealing washer.

##### Refitting

21 Refitting is a reversal of removal, but use a new sealing washer.

#### Fuel pressure regulator

##### Removal

22 Disconnect the battery negative (earth) lead (refer to Chapter 5, Section 1).

23 Relieve the fuel system pressure as described in Part B, Section 5.

24 Disconnect the vacuum hose from the top of the regulator (see illustration).

25 Release the clip and disconnect the fuel return hose from the base of the regulator.

26 Undo the regulator bracket retaining bolts, withdraw the regulator from the fuel rail and recover the O-ring seal. Plug the fuel rail while the regulator is removed.

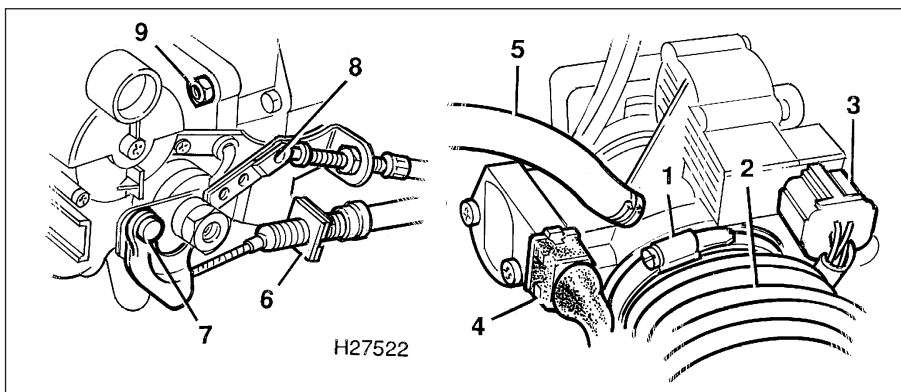

12.4 Stepper motor and throttle potentiometer details

- |                           |                           |                             |
|---------------------------|---------------------------|-----------------------------|
| 1 Intake hose clip        | 4 Potentiometer multiplug | 7 Cam lever                 |
| 2 Intake hose             | 5 Breather hose           | 8 Kick-down cable cam lever |
| 3 Stepper motor multiplug | 6 Throttle cable bracket  | 9 Throttle housing nuts     |



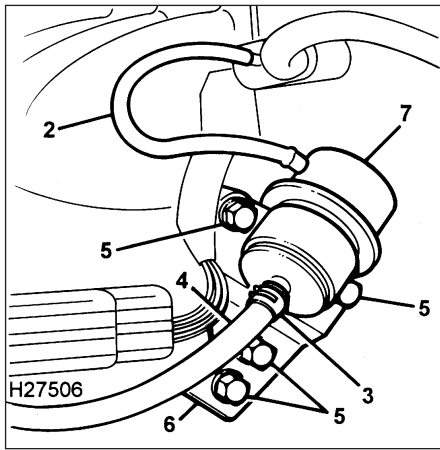

12.24 Fuel pressure regulator attachments

- 2 Vacuum hose
- 3 Fuel return hose clip
- 4 Fuel return hose
- 5 Regulator bracket retaining bolts
- 6 Regulator bracket
- 7 Fuel pressure regulator

**Refitting**

27 Refitting is a reversal of removal, but use a new O-ring seal.

**Plenum chamber**

**Removal**

- 28 Disconnect the battery negative (earth) lead (refer to Chapter 5, Section 1).
- 29 Slacken the hose clip and detach the air intake trunking from the throttle housing.
- 30 Undo the four nuts securing the throttle housing to the plenum chamber, ease the housing off the studs, and move it slightly to one side.
- 31 Disconnect the vacuum hoses at each end of the plenum chamber.

- 32 Disconnect the purge control valve hose from the plenum chamber (see illustration).
- 33 Unscrew the brake servo vacuum hose banjo union bolt and recover the two copper washers from the banjo union.
- 34 Detach the engine breather hose from the plenum chamber.
- 35 Disconnect the fuel temperature sensor wiring multiplug.
- 38 Undo the two bolts securing the plenum chamber mounting brackets to the camshaft cover.
- 39 Undo the six bolts securing the rear of the plenum chamber to the inlet manifold.
- 40 Lift the plenum chamber off the manifold, and recover the gasket.
- 41 Clean the manifold and plenum chamber mating faces and obtain a new gasket.

**Refitting**

42 Refitting is a reversal of removal. Use a new gasket and tighten the nuts and bolts to the specified torque.

**Fuel injectors and fuel rail**

**Removal**

- 43 Disconnect the battery negative (earth) lead (refer to Chapter 5, Section 1).
- 44 Relieve the fuel system pressure as described in Part B, Section 5.
- 45 Remove the plenum chamber as described previously.
- 46 Undo the four bolts and disconnect the fuel feed hose flange bracket from the side of the fuel rail. Plug the hose and fuel rail after disconnection.
- 47 Disconnect the multiplugs from each of the four injectors and move the injector wiring harness aside.
- 48 Disconnect the vacuum hose from the top of the fuel pressure regulator.
- 49 Release the clip and disconnect the fuel return hose from the base of the regulator.

- 50 Undo the regulator bracket retaining bolts, withdraw the regulator from the fuel rail and recover the O-ring seal. Plug the fuel rail while the regulator is removed.
- 51 Undo the three bolts securing the fuel rail to the inlet manifold.
- 52 Ease the four injectors out of their inlet manifold locations, and lift up the injector and fuel rail assembly. Recover the O-ring seal from each injector outlet.
- 53 Extract the retaining clips, and remove the injectors from the fuel rail. Recover the O-ring seal from each injector inlet.

**Refitting**

54 Refitting is a reversal of removal, but renew the injector inlet and outlet O-rings.

**Electronic control unit and relay module**

**Removal**

- 55 Lift the charcoal canister out of its mounting bracket and move it to one side.
- 56 Release the relay module from the bracket on the front of the ECU.
- 57 Disconnect the two wiring multiplugs and the vacuum hose, then undo the three bolts and remove the ECU from the mounting bracket.

**Refitting**

58 Refitting is a reversal of removal.

**Inertia switch**

**Removal**

- 59 Disconnect the wiring multiplug, undo the two screws and remove the switch from the engine compartment bulkhead.

**Refitting**

60 Refitting is a reversal of removal.

**Boost control solenoid (Turbocharged engines)**

**Removal**

- 61 Refer to Chapter 5, and remove the battery.
- 62 Slacken the clip and release the air intake hose on the side of the air cleaner body.
- 63 Slacken the clip and release the boost control solenoid valve hose from its connection next to the air intake hose on the air cleaner.
- 64 Undo the two bolts on the side of the air cleaner body and remove the unit from the engine compartment.
- 65 Release the clips and disconnect the three hoses from the boost control solenoid.
- 66 Disconnect the wiring multiplug, undo the retaining bolt and remove the solenoid from the battery tray.

**Refitting**

67 Refitting is a reversal of removal.

**Camshaft sensor (Turbocharged engines)**

**Removal**

- 68 Disconnect the sensor wiring harness at the connector.

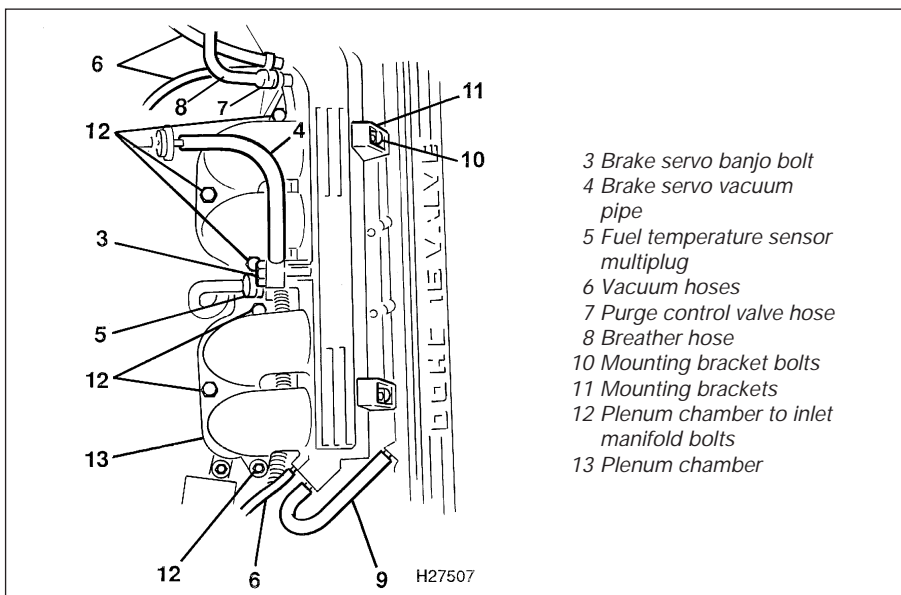

12.32 Plenum chamber attachment details

**69** Undo the retaining bolt and remove the sensor from the housing on the end of the cylinder head.

### Refitting

**70** Refitting is a reversal of removal.

### 13 Turbocharger - description and precautions

Refer to Part B, Section 13.

### 14 Turbocharger - removal and refitting



### Removal

- 1** Disconnect the battery negative (earth) lead (refer to Chapter 5, Section 1).
- 2** Drain the cooling system as described in Chapter 1.
- 3** Remove the air cleaner assembly as described in Section 2.
- 4** Undo the two nuts and remove the oil return hose elbow from the side of the sump.
- 5** Undo the three nuts and separate the exhaust downpipe from the turbocharger outlet flange. Recover the flange gasket.
- 6** Undo the two bolts securing the coolant

pipe over the top of the exhaust manifold.

**7** Release the oxygen sensor multiplug from the thermostat housing, disconnect the multiplug and remove the harness from the clip on the top hose.

**8** Slacken the hose clip and remove the coolant pipe from the hose on the side of the thermostat housing.

**9** Slacken the hose clip and remove the air intake hose from the turbocharger.

**10** Slacken the two hose clips and remove air the outlet hose from the turbocharger and intercooler.

**11** Disconnect the oil feed pipe union at the turbocharger.

**12** Disconnect the vacuum hose at the wastegate solenoid valve.

**13** Disconnect the coolant feed and return hoses at the turbocharger.

**14** Release the clip on the turbocharger vacuum hose and remove the hose from the turbocharger.

**15** On models without air conditioning, undo the nuts and remove the alternator heat shield.

**16** Undo the exhaust manifold retaining nuts and bolts and withdraw the manifold complete with turbocharger assembly off the studs. Recover the manifold gasket.

**17** Undo the nuts securing the turbocharger to the exhaust manifold and remove the turbocharger. Recover the flange gasket .

**18** Thoroughly clean all the joint mating faces prior to refitting.

### Refitting

**19** Refitting is a reversal of removal bearing in mind the following points:

- Use new gaskets at all the flange joints and new nuts at the turbocharger to manifold connection.*
- Tighten all nuts and bolts to the specified torque.*
- Refill the cooling system and top up the engine oil as described in Chapter 1.*

### 15 Turbocharger - examination and renovation

Refer to Part B, Section 15.

### 16 Intercooler - removal and refitting

The intercooler is removed as an assembly with the cooling system radiator. Refer to Chapter 3, Section 7 for details.

### 17 Exhaust system - general information and component renewal

Refer to Part A, Section 13 for exhaust system details and to Part E, Section 3, for information on the catalytic converter.

# Chapter 4 Part D: Fuel and exhaust systems – Honda PGM-Fi injection engines

## Contents

Accelerator cable - removal, refitting and adjustment . . . . .	3	Fuel gauge sender unit - removal and refitting . . . . .	7
Accelerator cable and linkage check and lubrication . . .See Chapter 1		Fuel injection system - general information . . . . .	10
Accelerator pedal - removal and refitting . . . . .	4	Fuel injection system - testing and adjustment . . . . .	11
Air cleaner assembly and intake components - removal and refitting . . . . .	2	Fuel injection system components - removal and refitting . . . . .	12
Air cleaner element renewal . . . . .See Chapter 1		Fuel pump - removal and refitting . . . . .	6
Catalytic converter - general information and precautions . . . . .See Chapter 4E		Fuel system - depressurisation . . . . .	5
Cruise control system - general information . . . . .	13	Fuel tank - removal, inspection and refitting . . . . .	8
Cruise control system components - removal and refitting . . . . .	14	General information and precautions . . . . .	1
Exhaust manifold - removal and refitting . . . . .See Chapter 2A		Inlet manifold - removal and refitting . . . . .See Chapter 2A	
Exhaust system - general information and component renewal . . . . .	15	Oxygen sensor . . . . .See Chapter 4E	
Exhaust system check . . . . .See Chapter 1		Underbody fuel/brake line check . . . . .See Chapter 1	
Fuel filter renewal . . . . .See Chapter 1		Underbonnet check for fluid leaks and hose condition . . . . .See Chapter 1	
		Unleaded petrol - general information and usage . . . . .	9

## Degrees of difficulty

<b>Easy</b> , suitable for novice with little experience 	<b>Fairly easy</b> , suitable for beginner with some experience 	<b>Fairly difficult</b> , suitable for competent DIY mechanic 	<b>Difficult</b> , suitable for experienced DIY mechanic 	<b>Very difficult</b> , suitable for expert DIY or professional 
---	--	--	---	--

## Specifications

### General

System type . . . . .	Programmed fuel injection system with sequential injection
Idle speed:	
2.5 litre engines . . . . .	720 to 820 rpm
2.7 litre engines . . . . .	670 to 770 rpm
Idle mixture CO content	
Models without catalytic converter . . . . .	0.25 to 0.75%
Models with catalytic converter * . . . . .	0.1%
* <i>Non-adjustable - controlled by ECU</i>	
Fuel octane rating **:	
Models without catalytic converter . . . . .	97 RON leaded or 95 RON unleaded
Models with catalytic converter . . . . .	95 RON unleaded only
** <i>See text - Section 9</i>	

### Fuel Pump

Type . . . . .	Nippon Denso, electric
Output pressure . . . . .	4.1 bar
Regulated pressure . . . . .	2.0 bar
Delivery rate (at 12 volts in 10 seconds) . . . . .	230 cc

### Torque wrench settings

	Nm	lbf ft
Electronic idle control valve retaining bolts . . . . .	22	16
Fast idle valve retaining bolts . . . . .	12	9
Fuel filter banjo union bolts . . . . .	38	28
Fuel pump banjo union bolt . . . . .	22	16
Fuel rail banjo union bolts . . . . .	22	16
Throttle body retaining nuts and bolts . . . . .	22	16
Fuel tank drain plug . . . . .	50	37
Fuel tank strap locknuts . . . . .	22	16
Exhaust front pipes to manifold . . . . .	35	26
Exhaust section flange nuts . . . . .	35	26

## 1 General information and precautions

The fuel system used on V6 engine Rover models consists of a centrally-mounted fuel tank, electric fuel pump and Honda PGM-Fi programmed fuel injection system. A more detailed description of the system is contained in Section 10.

The exhaust system consists of a front, intermediate and rear section, suspended from the underbody on rubber mountings, and bolted to two cast iron manifolds at the front. A catalytic converter is fitted between the front and intermediate sections on later models and a flexible joint is also incorporated in the front section, to allow for engine and exhaust system movement.

### Precautions



**Warning:** Many of the procedures in this Chapter require the removal of fuel lines and connections, which may result in some fuel spillage. Petrol is extremely flammable, so take extra precautions when you work on any part of the fuel system. Don't smoke, or allow open flames or bare light bulbs, near the work area. Don't work in a garage where a natural gas-type appliance (such as a water heater or clothes dryer) with a pilot light is present. If you spill any fuel on your skin, rinse it off immediately with soap and water. When you perform any kind of work on the fuel system, wear safety glasses, and have a Class B type fire extinguisher on hand. Before carrying out any operation on the fuel system, refer also to the precautions given in "Safety first!" at the beginning of this manual, and follow them implicitly. Petrol is a highly-dangerous and volatile liquid, and the precautions necessary when handling it cannot be overstressed.

Reference must also be made to Chapter 5, Section 1 for precautionary notes concerning the ignition system and battery disconnection, and to any further safety-related text



2.1 Release the coil HT cable from the clip on top of the upper intake trunking

contained within the appropriate Section, before working on the vehicle.

Certain adjustment points in the fuel system are protected by tamperproof caps, plugs or seals. In some territories, it is an offence to drive a vehicle with broken or missing tamperproof seals. Before disturbing a tamperproof seal, first check that no local or national laws will be broken by doing so, and fit a new tamperproof seal after adjustment is complete, where required by law. Do not break tamperproof seals on any vehicle whilst it is still under warranty.

When working on fuel system components, scrupulous cleanliness must be observed and care must be taken not to introduce any foreign matter into the fuel lines or components.

## 2 Air cleaner assembly and intake components - removal and refitting



**Note:** Air cleaner element renewal is described in Chapter 1.

**Note:** Due to the limited space available, access to the air intake trunking and air cleaner assembly can be improved if the battery is removed first. If this is to be done, refer to Chapter 5, Section 1, for precautions concerning battery disconnection.

### Air intake trunking

#### Removal

1 Release the coil HT cable from the clip on



2.2 Remove the breather pipe from the side of the upper intake trunking

top of the upper intake trunking (see illustration).

2 Undo the breather pipe support bracket bolt and remove the breather pipe from the side of the upper intake trunking (see illustration).

3 Slacken the clip securing the upper trunking to the throttle body and the clip securing the lower intake trunking to the air cleaner assembly.

4 Release the trunking from the throttle body and air cleaner; slacken the centre clip, securing the upper and lower trunking parts together.

5 Separate the upper trunking from the lower trunking and manipulate both parts out of the engine compartment.

#### Refitting

6 Refitting is a reversal of removal.

### Air cleaner assembly

#### Removal

7 Remove the air intake trunking as described previously.

8 Release the clip securing the resonator vacuum hose to the front of the air cleaner assembly and undo the wiring harness support clip bolt at the rear (see illustrations).

9 Slacken the air duct retaining clip.

10 Undo the two bolts securing the air cleaner assembly to the battery tray (see illustrations).



2.8a Release the clip securing the resonator vacuum hose to the front of the air cleaner assembly . . .



2.8b . . . and undo the wiring harness support clip bolt (arrowed) at the rear



2.10a Undo the rear bolt arrowed . . .





2.10b . . . and front bolt, securing the air cleaner assembly to the battery tray



3.1 Slip the accelerator inner cable end out of the slot on the throttle lever



3.2 Slacken the outer cable locknuts, then withdraw the outer cable from the support bracket

11 Release the air cleaner assembly from the air duct, disengage the locating pegs and lift the assembly out of the engine compartment.

#### Refitting

12 Refitting is a reversal of removal.

#### Air duct

#### Removal

13 Remove the battery as described in Chapter 5.

14 Remove the air intake trunking and the air cleaner assembly as described previously.

15 Undo the three bolts and lift out the battery tray.

16 Undo the air duct upper retaining bolt, release the duct from the resonator and manipulate the assembly from its location.

#### Refitting

17 Refitting is a reversal of removal.

### 3 Accelerator cable - removal, refitting and adjustment



#### Removal

1 Open the throttle fully by hand, and slip the inner cable end out of the slot on the throttle lever (see illustration).

2 Slacken the outer cable locknuts, then withdraw the outer cable from the support bracket (see illustration).



3.5 Release the cable from the support clips

3 From inside the car, release the turnbuckles and lift out the trim panel over the clutch, brake and accelerator pedals.

4 Prise the retaining clip from the top of the accelerator pedal, and disconnect the inner cable.

5 Release the cable from the engine compartment bulkhead, and the support clips; withdraw the cable from the car (see illustration).

#### Refitting and adjustment

6 Refitting is a reversal of removal. Adjust the cable by means of the outer cable locknuts, to give a small amount of free play with the throttle closed. The adjustment is correct when there is approximately 10 to 12 mm of deflection on the inner cable.

7 Check that the throttle butterfly opens fully with the accelerator pedal depressed to the floor, and closes completely when released.

### 4 Accelerator pedal - removal and refitting

Refer to Part A, Section 4, but note that the accelerator pedal switch is only fitted to certain models. On models equipped with cruise control, release the cruise control cable from the pedal in the same way as the accelerator cable.



5.4 Releasing the fuel system pressure at the bleed screw on the banjo union

### 5 Fuel system - depressurisation



**Note:** Refer to the precautions contained in Section 1 before proceeding.

1 The fuel system referred to in this Chapter is defined as the fuel tank and tank-mounted fuel pump/fuel gauge sender unit, the fuel filter, the fuel pressure regulator, the fuel injectors, and the metal pipes and flexible hoses of the fuel lines between these components. Most of these contain fuel which will be under pressure while the engine is running and/or while the ignition is switched on.

2 The pressure will remain for some time after the ignition has been switched off, and must be relieved before any of these components are disturbed for servicing or repair work.

3 Disconnect the battery negative (earth) lead (refer to Chapter 5, Section 1).

4 Place absorbent rags around the bleed screw in the centre of fuel filter outlet union banjo bolt, then slowly unscrew the bleed screw to release the system pressure (see illustration).

5 Once the pressure has been completely relieved, tighten the bleed screw and dispose of the rags safely.

### 6 Fuel pump - removal and refitting

Refer to Part A, Section 6.

### 7 Fuel gauge sender unit - removal and refitting

Refer to Part A, Section 7.

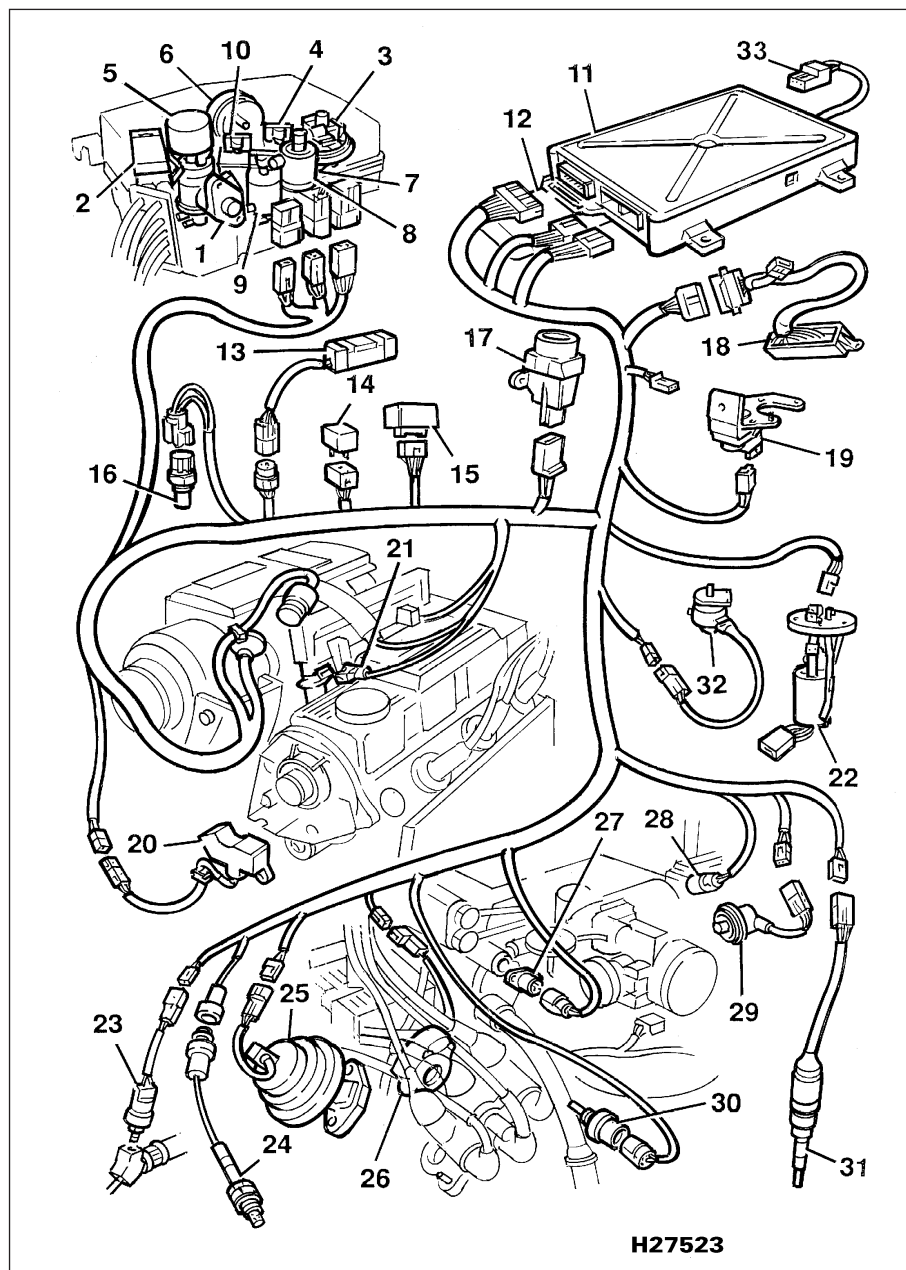

10.1 Main components of the PGM-Fi programmed fuel injection system

**Note:** Components and locations may differ slightly between models

- |   |                                       |                                     |
|---|---------------------------------------|-------------------------------------|
| 1 Ignition timing sensor                            | 10 Bypass control solenoid valve B    | 22 Fuel pump                        |
| 2 Manifold absolute pressure sensor                 | 11 Main system ECU                    | 23 Power steering switch            |
| 3 Constant vacuum control valve                     | 12 Cooling fan timer module           | 24 Oxygen sensor                    |
| 4 Air suction control solenoid valve                | 13 Injector resistor pack             | 25 EGR valve lift sensor            |
| 5 EGR control solenoid valve                        | 14 Air conditioning clutch relay      | 26 TDC sensor                       |
| 6 Throttle dashpot air filter                       | 15 Main system relay                  | 27 Intake air temperature sensor    |
| 7 Air reservoir                                     | 16 Oil temperature sensor             | 28 Electronic idle control valve    |
| 8 Pressure regulator control cut-off solenoid valve | 17 Inertia switch                     | 29 Throttle angle sensor            |
| 9 Bypass control solenoid valve A                   | 18 Transmission shift position switch | 30 Coolant temperature sensor       |
|   | 19 Absolute pressure sensor           | 31 Speedometer transducer           |
|   | 20 Crank/cylinder sensor              | 32 Resonator control valve solenoid |
|   | 21 Fuel injectors                     | 33 ECU link connector               |

## 8 Fuel tank - removal, inspection and refitting

Refer to Part A, Section 8.

## 9 Unleaded petrol - general information and usage

**Note:** The information given in this Chapter is correct at the time of writing, and applies only to petrols currently available in the UK. If updated information is thought to be required, check with a Rover dealer. If travelling abroad, consult one of the motoring organisations (or a similar authority) for advice on the petrols available and their suitability for your vehicle.

1 The recommended fuel is given in the Specifications at the beginning of this Chapter, followed by the equivalent petrol on sale in the UK.

2 RON and MON are different testing standards; RON stands for Research Octane Number (also written as RM), while MON stands for Motor Octane Number (also written as MN).

3 All non-catalyst equipped V6 engine models covered by this manual are designed to run on leaded or unleaded petrols. Depending on the petrol used, the ignition timing will have to be adjusted accordingly. Details of this procedure are covered in Chapter 5, Section 10. Only unleaded petrol may be used in those models fitted with a catalytic converter.

## 10 Fuel injection system - general information

The Honda PGM-Fi programmed fuel injection system is used on all V6 engine models covered by this manual. There are detail differences between the system used on the 2.5 litre engines and that used on 2.7 litre models, but these are of a minor nature and mainly reflect the system's development over the years. The system is a complex and highly sophisticated total engine management package, controlling the fuel injection, the fuel and exhaust emissions, and the ignition system, from one electronic control unit (ECU) (see illustration).

The tank-mounted fuel pump supplies fuel under pressure to the fuel rails; the pressure being controlled by the fuel pressure regulator. Fuel from the fuel rails is supplied to the fuel injectors which are then operated by the ECU according to a number of operating parameters.

The ECU contains memories for the basic fuel injector opening times for various engine speed and load conditions. Numerous sensors on and around the engine are used to

modify these basic values to “fine-tune” the injector opening times to suit precise operating conditions. Information on crankshaft speed and position, coolant temperature, intake air temperature, ambient air temperature, manifold pressure, atmospheric pressure and vehicle speed is supplied to the ECU by the sensors, to enable initial injection time to be established. Additional sensors are used, according to model and equipment levels, to supply information on exhaust emissions, air conditioning system operation, automatic transmission shift position, etc.

Engine idle speed is also controlled by the ECU in conjunction with an electronic idle control valve. This valve changes the amount of air bypassing into the inlet manifold in response to sensor information processed by the ECU. This results in a stabilized idle speed irrespective of additional loads imposed on the engine from such sources as the alternator, power steering pump, automatic transmission, air conditioning compressor, or other external factors such as temperature and altitude. Additionally, a temperature conscious fast idle control bypass valve is used to increase the amount of air bypassing into the inlet manifold during warm-up conditions.

Should certain elements of the system fail, the ECU can implement a back-up facility, allowing the system to operate at reduced performance until the fault can be rectified.

A self-diagnosis function is also provided whereby any faults detected by the ECU are stored in its memory and displayed as codes by a flashing red LED whenever the ignition is switched on. A second LED is also provided to indicate whether the initial (manually set) idle speed adjustment is correct. Both these LED's are located on the front of the ECU and can be seen by looking under the front of the driver's seat.

## 11 Fuel injection system - testing and adjustment



### Testing

1 If a fault appears in the fuel injection system (indicated by the red LED on the ECU flashing a series of codes), first ensure that all the system wiring connectors are securely connected and free of corrosion. Then ensure that the fault is not due to poor maintenance; ie, check that the air cleaner filter element is clean, the spark plugs are in good condition and correctly gapped, the cylinder compression pressures are correct, and that the engine breather hoses are clear and undamaged, referring to the relevant Parts and Sections of this Chapter, and to Chapters 1 and 2 for further information.

2 If these checks fail to reveal the cause of

the problem, the vehicle should be taken to a suitably equipped Rover dealer for the fault codes to be interpreted and the fault isolated. This will alleviate the need to test all the system components individually, which is a time-consuming operation that carries an element of risk of damaging the ECU.

### Adjustment

#### Engine tuning procedure

3 The fuel injection system is such that once the initial engine idle speed and mixture settings have been set, they are then controlled by the system's ECU for all operating conditions. Although the settings should be checked at the recommended service intervals, it is unlikely that any adjustment will be needed unless a new component has been fitted. Note also that the idle mixture setting can only be adjusted on early models that are not equipped with a catalytic converter.

4 Before making any changes to the settings of the fuel injection system, ensure that the spark plug gaps are correctly set, the air cleaner element is clean, there are no leaks in the exhaust system, and the ignition system is operating correctly. Ensure that all breather and vacuum hoses are connected, and that none are perished or kinked.

5 Check that there is the correct amount of free play in the accelerator cable, and that the throttle lever rests against its stop in the released condition. Adjust the cable as described in Section 3 if necessary.

6 Temperature effects, and engine and transmission oil drag, can influence the idle speed and mixture settings, and it is important that the following warm-up procedure is adopted before attempting any adjustments.

7 Drive the car on the road for approximately two to four miles, dependent on summer or winter conditions, in a normal manner, without excessive load, engine speed or road speed.

8 Return the car to the working area, ensure that the steering is in the straight ahead position then switch the engine off and connect a tachometer to the engine in accordance with the equipment

manufacturer's instructions. If the mixture setting is being checked, connect an exhaust gas analyser (CO meter) in accordance with the equipment manufacturer's instructions also. The analyser should be warmed up, correctly calibrated and ready for immediate use. Commence the adjustment procedure described below immediately.

#### Idle speed adjustment

9 With the engine idling, check the yellow LED display on the fuel system ECU, by looking under the front of the driver's seat. The LED is visible through the window on the ECU case (see illustration). If the LED is not illuminated, the idle speed is correct and no adjustment is required. If the LED is illuminated or blinking, adjustment is required.

10 Switch off all electrical accessories, and ensure that they remain switched off throughout the adjustment procedure.

11 If the LED is illuminated constantly (not blinking), turn the adjustment screw on the idle valve anti-clockwise to correct the setting. If the LED is blinking, turn the adjustment screw clockwise (see illustration). Always turn the adjustment screw in 90° increments, and wait thirty seconds for the idle speed to stabilise. Check the idling speed on the tachometer and compare it with the figures given in the Specifications. Repeat the adjustment until the setting is correct.

#### Idle mixture adjustment

12 As mentioned earlier, the idle mixture can only be adjusted on models without a catalytic converter.

13 According to model, the idle mixture adjuster will be located in one of three places:  
2.5 litre models - In the control box on the engine compartment bulkhead (see illustration).

2.7 litre models - In the control box on the engine compartment bulkhead, or on the fuse and relay box in the fascia on the driver's side, or in front of the fuel system ECU under the driver's seat (see illustrations).



11.9 The ECU viewing window where the red and yellow LEDs can be seen (driver's seat removed for clarity)



11.11 Idle speed adjustment screw (arrowed) on the idle valve. (On 2.5 litre engines the screw is on the side of the valve)





**11.13a** This is actually the ignition timing sensor/adjuster (arrowed) in the control box on 2.7 litre engines, but on 2.5 litre models, this is where you will find the idle mixture adjuster

**14** Locate the adjuster and hook out the tamperproof cap over the adjusting screw, if fitted.

**15** Refer to the engine tuning procedure information contained above before starting.

**16** Switch off all electrical accessories, and ensure that they remain switched off throughout the adjustment procedure.

**17** If, during the adjustment procedure, the cooling fan operates, or if adjustment is not completed within two minutes, accelerate the engine to 2000 rpm, and hold this speed for ten seconds. Repeat this every two minutes until the adjustments are completed.

**18** With the engine idling and the exhaust gas analyser connected, take a reading of the exhaust gas CO content. If this is not as given in the Specifications, turn the screw clockwise to enrich the mixture, or anti-clockwise to weaken it as necessary.

**19** On completion, disconnect the exhaust gas analyser and check the idle speed setting as described above.

## 12 Fuel injection system components - removal and refitting



**Note:** Refer to the precautions contained in Section 1 before proceeding.

### Atmospheric pressure sensor Removal

**1** Open the fusebox cover under the fascia on the driver's side.

**2** Undo the retaining screw and withdraw the sensor from the mounting bracket.

**3** Disconnect the wiring multiplug and remove the sensor.

### Refitting

**4** Refitting is a reversal of removal.

### Resonator

#### Removal

**5** Apply the handbrake, jack up the front of the car and support it on axle stands.

**6** Undo the two screws and one bolt securing

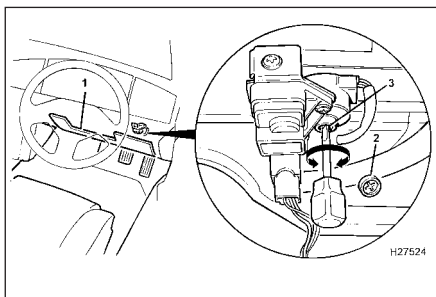

**11.13b** Idle mixture adjuster location on early 2.7 litre non-catalyst engines

- 1 Remove fusebox cover for access
- 2 Hook out tamperproof cap
- 3 Turn adjuster as required

the access panel to the underside of the front wheelarch on the left-hand side.

**7** Undo the four remaining screws, disengage the access panel from the front spoiler, and remove it from under the car.

**8** Disconnect the wiring multiplug from the control solenoid.

**9** Disconnect the vacuum hose at the T-piece connector.

**10** Undo the two bolts and withdraw the resonator assembly from under the front wheelarch.

**11** Remove the spacers and rubber mountings from the resonator.

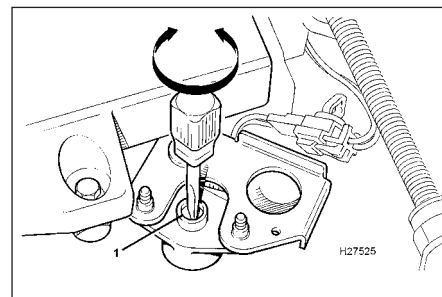

**11.13c** Idle mixture adjuster screw (1) under the driver's seat on later 2.7 litre non-catalyst engines

**12** With the unit removed, the control solenoid and valve control diaphragm, together with the pipes and hoses, can be removed as required.

### Refitting

**13** Refitting is a reversal of removal.

### Throttle body

#### Removal

**14** Partially drain the cooling system as described in Chapter 1, to below the level of the throttle body.

**15** Open the throttle fully by hand, and slip the accelerator inner cable end out of the slot on the throttle lever (see illustration).

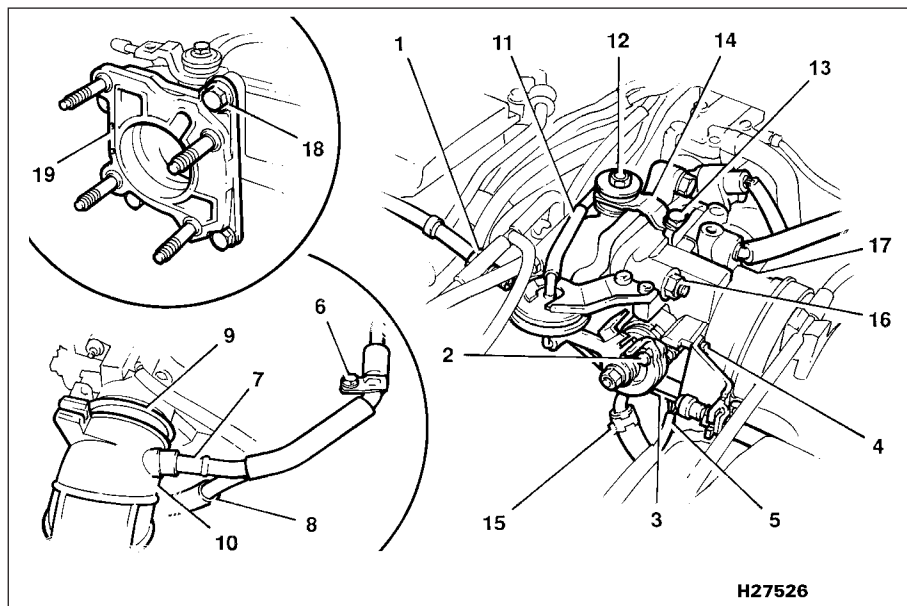

**12.15** Throttle body components and attachment details

- |  |                                   |                                     |
|--|-----------------------------------|-------------------------------------|
| 1 Outer accelerator cable                | 7 Breather pipe upper connection  | 12 Support strap rear bolt          |
| 2 Inner accelerator connection           | 8 Breather pipe lower connection  | 13 Support strap front bolt         |
| 3 Kick-down cable                        | 9 Intake trunking clip            | 14 Support strap                    |
| 4 Kickdown cable support bracket screws  | 10 Intake trunking                | 15 Lower air hose                   |
| 5 Throttle angle sensor wiring multiplug | 11 Throttle diaphragm vacuum hose | 16 Throttle body retaining nuts     |
| 6 Breather pipe retaining bolt           |                                   | 17 Throttle body                    |
|  |                                   | 18 Rubber insulator retaining bolts |
|  |                                   | 19 Rubber insulator                 |





12.19 Throttle angle sensor wiring multiplug location



12.30 Undo the bolts securing the vacuum pipe and crankcase ventilation pipe support brackets



12.31 Disconnect the wiring multiplug from the idle control valve

16 Slacken the outer cable locknuts, then withdraw the outer cable from the support bracket.

17 On automatic transmission models, release the kickdown cable inner cable end from the throttle lever.

18 Undo the two screws securing the kickdown cable support bracket to the throttle body and move the bracket and cable to one side.

19 Disconnect the wiring multiplug from the throttle angle sensor (see illustration).

20 Release the coil HT cable from the clip on top of the air intake trunking.

21 Undo the breather pipe support bracket bolt and remove the breather pipe from the side of the intake trunking.

22 Slacken the clip and release the trunking from the throttle body.

23 Disconnect the vacuum hose from the throttle diaphragm.

24 Undo the two bolts and remove the support strap from the top of the throttle body.

25 Release the clip and disconnect the lower air hose from the underside of the throttle body.

26 Undo the four nuts, move the air intake trunking aside, and withdraw the throttle body from the studs of the rubber insulator.

27 If required, the rubber insulator can be removed from the inlet manifold after undoing the four retaining bolts.

**Refitting**

28 Refitting is a reversal of removal. Adjust the accelerator cable as described in Section 3, and refill the cooling system (Chapter 1).

**Electronic idle control valve**

**Removal**

29 Partially drain the cooling system as described in Chapter 1, to below the level of the idle control valve.

30 Undo the bolts securing the vacuum pipe and crankcase ventilation pipe support brackets (see illustration).

31 Disconnect the wiring multiplug from the idle control valve (see illustration).

32 Release the clips and disconnect the two coolant hoses from the idle control valve.

33 Undo the two bolts and remove the idle control valve from the inlet manifold. Recover the sealing O-ring from the base of the valve.

**Refitting**

34 Refitting is a reversal of removal but use a new O-ring seal. Refill the cooling system (Chapter 1), and adjust the idle speed (Section 11).

**Dashpot diaphragm assembly**

**Removal**

35 Disconnect the vacuum hose from the top of the diaphragm (see illustration).

36 Undo the two screws securing the diaphragm bracket to the throttle body.

37 Disconnect the operating rod from the throttle lever and remove the diaphragm assembly.

**Refitting**

38 Refitting is a reversal of removal.

**Fast idle valve**

**Removal**

39 Partially drain the cooling system as described in Chapter 1, to below the level of the fast idle valve.

40 Release the clips and disconnect the two coolant hoses from the fast idle valve (see illustration).

41 Undo the three bolts and remove the

valve from the inlet manifold. Recover the two O-ring seals.

**Refitting**

42 Refitting is a reversal of removal, but renew the O-ring seals and refill the cooling system, as described in Chapter 1 on completion.

**Front fuel rail and injectors**

**Removal**

43 Disconnect the battery negative (earth) lead (refer to Chapter 5, Section 1).

44 Relieve the fuel system pressure as described in Section 5.

45 Disconnect the spark plug HT leads from the three rear spark plugs, and identify the leads for correct reconnection.

46 Release the HT leads from the support clips and from the top of the inlet manifold cover and move the leads clear (see illustration).

47 Undo the bolt securing the fuel pipe clip at the corner of the inlet manifold cover.

48 Release the clips and disconnect the breather hose from the inlet manifold cover and camshaft cover.

49 Open the throttle fully by hand, and slip the accelerator inner cable end out of the slot on the throttle lever.

50 Slacken the outer cable locknuts; withdraw the outer cable from the support bracket. Release the cable from the clips and move it clear.

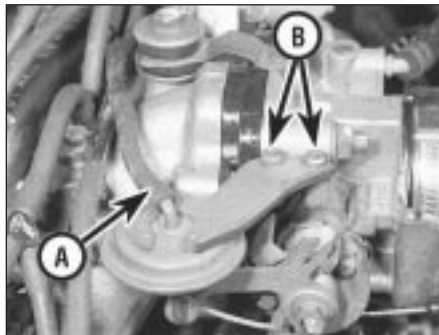

12.35 Dashpot diaphragm vacuum hose (A) and retaining screws (B)

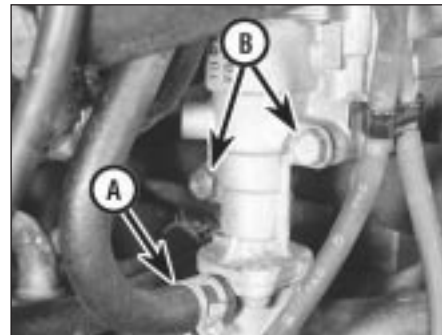

12.40 Fast idle valve coolant hose (A) and mounting bolts (B)

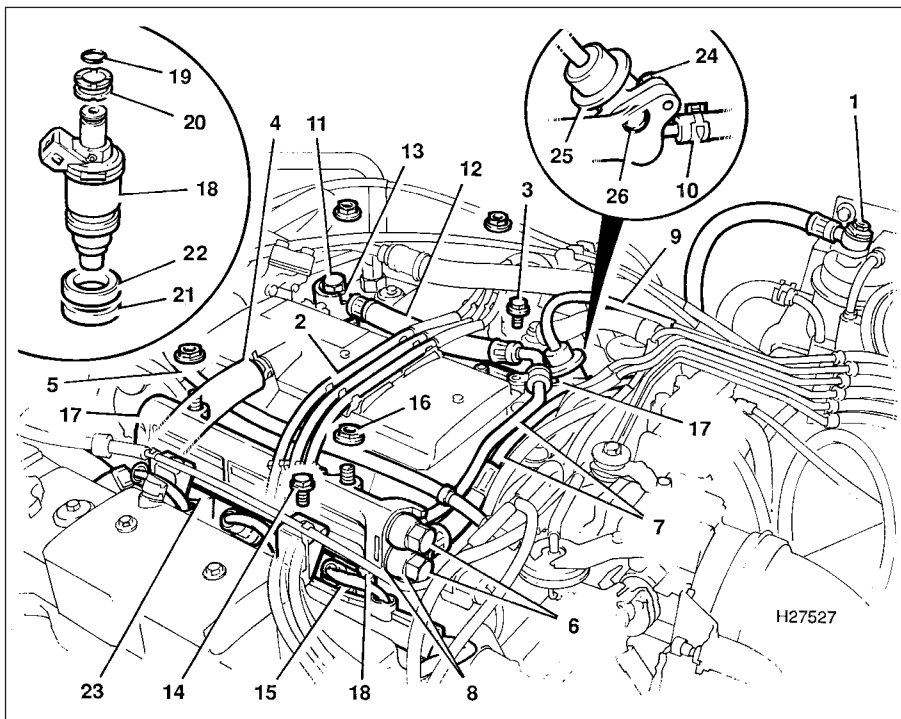

12.46 Fuel rails and injector components and attachments

- |  |   |  |
|--|---|--|
| 1 Fuel filter banjo bolt bleed screw   | 9 Fuel pressure regulator vacuum hose   | 17 Fuel rail                               |
| 2 HT lead support clips                | 10 Fuel return hose                     | 18 Fuel injector                           |
| 3 Fuel pipe clip retaining bolt        | 11 Fuel pipe banjo union bolt           | 19 O-ring                                  |
| 4 Breather hose                        | 12 Fuel pipe                            | 20 Cushion ring                            |
| 5 Accelerator cable                    | 13 Banjo union sealing washer locations | 21 Insulator                               |
| 6 Fuel pipe banjo union bolts          | 14 Harness bracket retaining bolts      | 22 Sealing ring                            |
| 7 Fuel pipes                           | 15 Fuel injector multiplugs             | 23 Manifold spacers                        |
| 8 Banjo union sealing washer locations | 16 Fuel rail retaining nuts             | 24 Fuel pressure regulator retaining bolts |
|  |   | 25 Fuel pressure regulator                 |
|  |   | 26 O-ring                                  |

- 51 Disconnect the cruise control vacuum hose at the T-piece connector, release the hose from the support clips and move it clear.
- 52 Undo the two banjo union bolts securing the fuel pipes to the front fuel rail. Release the pipes and collect the copper washers. Cover the open unions after disconnection then move the pipes away.
- 53 Undo the bolts securing the two harness brackets at the front of the fuel rail and move the brackets aside.
- 54 Disconnect the wiring multiplugs from the three fuel injectors (see illustration).
- 55 Undo the two fuel rail retaining nuts and lift the fuel rail off the injectors.
- 56 Withdraw the injectors from their locations and collect the O-ring and cushion ring at the top, and the insulator and sealing ring at the bottom from each injector.
- 57 Collect the two spacers from the inlet manifold.

#### Refitting

58 Refitting is a reversal of removal, but renew the O-rings, cushion rings, insulators and sealing rings on each injector, and use new washers on the fuel pipe banjo unions.

Tighten the banjo union bolts to the specified torque.

59 Reconnect and adjust the accelerator cable as described in Section 3.

#### Rear fuel rail and injectors

##### Removal

60 Carry out the operations described in paragraphs 43 to 47 above.



12.54 Disconnect the injector wiring multiplugs

- 61 Disconnect the vacuum hose from the top of the fuel pressure regulator.
- 62 Release the clip and disconnect the fuel return hose from the fuel pressure regulator. Plug the hose and regulator union.
- 63 Undo the banjo union bolt securing the fuel pipe to the rear fuel rail. Release the pipe and collect the copper washers. Cover the open union after disconnection then move the pipe away.
- 64 Undo the bolts securing the two harness brackets at the rear of the fuel rail and move the brackets aside.
- 65 Disconnect the wiring multiplugs from the three fuel injectors.
- 66 Undo the two fuel rail retaining nuts and lift the fuel rail off the injectors.
- 67 Withdraw the injectors from their locations and collect the O-ring and cushion ring at the top, and the insulator and sealing ring at the bottom from each injector.
- 68 Collect the two spacers from the inlet manifold.
- 69 If required the fuel pressure regulator can be removed from the fuel rail after removing the two retaining bolts. Collect the O-ring seal between regulator and fuel rail.

#### Refitting

70 Refitting is a reversal of removal; renew the O-rings, cushion rings, insulators and sealing rings on each injector, and use new washers on the fuel pipe banjo unions. Tighten the banjo union bolts to the specified torque. Renew the regulator O-ring if the regulator was removed.

#### Fuel pressure regulator

##### Removal

- 71 Disconnect the battery negative (earth) lead (refer to Chapter 5, Section 1).
- 72 Relieve the fuel system pressure as described in Section 5.
- 73 Disconnect the vacuum hose from the top of the fuel pressure regulator (see illustration).
- 74 Release the clip and disconnect the fuel return hose from the fuel pressure regulator. Plug the hose and pressure regulator union.
- 75 Undo the two bolts and remove the regulator. Collect the O-ring seal between regulator and fuel rail.

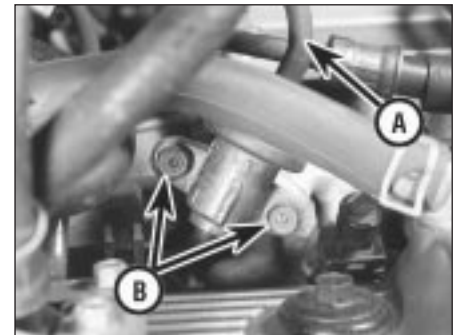

12.73 Fuel pressure regulator vacuum hose (A) and retaining bolts (B)



12.80 Disconnect the ECU wiring multiplugs

### Refitting

76 Refitting is a reversal of removal but use a new sealing O-ring.

### Electronic control unit

#### Removal

77 Disconnect the battery negative (earth) lead (refer to Chapter 5, Section 1).

78 Remove the driver's seat as described in Chapter 11.

79 Undo the four bolts securing the ECU to the floor. Lift off the ECU cover and collect the spacers between the ECU flange and the floor.

80 Disconnect the ECU wiring multiplugs (see illustration).

81 Where fitted, undo the two bolts and remove the cooling fan timer module from the ECU base (see illustration). Remove the ECU.

#### Refitting

82 Refitting is a reversal of removal.

### Inertia switch

#### Removal

83 On early models the switch is located behind the centre console inside the car.

84 Remove the stud from the centre console side cover on the left-hand side, and remove the cover.

85 Undo the two screws securing the inertia switch to the mounting plate, disconnect the wiring multiplug and remove the switch.

86 Check the operation of the switch by striking the forward-facing side hard against the palm of your hand. The setting button should trip out when this is done. If not, renew the switch.

87 On later models, disconnect the wiring multiplug, undo the two screws and remove the switch from the engine compartment bulkhead (see illustration).

#### Refitting

88 Refitting is a reversal of removal. Press the button down to reset the switch after installation.

### Main control box

89 In addition to the sensors, valves and



12.81 Where fitted, undo the two bolts and remove the cooling fan timer module

solenoids described previously in this Section, a number of additional units are located in the main control box mounted on the engine compartment bulkhead. These devices are used by the ECU for control of the fuel, ignition and emissions control systems. Many of the sensors utilise manifold vacuum for their operation and are connected by means of a series of numbered vacuum hoses and pipes to various locations on, and around, the engine. Three wiring multiplugs connect the sensors electrically to the main harness.

90 The layout, and number of sensors fitted, varies considerably according to engine, model year, emission equipment level, and vehicle accessories or options. Each of the sensors can be renewed separately, but testing, either individually, or as part of their respective system, must be entrusted to a dealer with dedicated test equipment.

#### Removal

91 Disconnect the battery negative (earth) lead (refer to Chapter 5, Section 1).

92 Slacken the two bolts securing the control box to the bulkhead.

93 Undo the three screws and lift off the control box upper cover (see illustration).

94 Note the connections, then release the wiring multiplugs from the mounting brackets on the front of the control box and disconnect them.

95 Remove the control box lower cover from the valve plate assembly.

96 Check that each of the vacuum hoses and



12.93 Undo the three screws and lift off the control box upper cover



12.87 Inertia switch location on the engine compartment bulkhead

its corresponding pipe on the pipe block is numbered. If not, label each hose and pipe.

97 Some of the sensors are accessible at this stage and if they are to be renewed individually, disconnect the vacuum hose, undo the screws and remove the relevant unit. If the complete control box is being removed, proceed as follows.

98 Pull the vacuum hoses off the pipe stubs (see illustration).

99 Undo the bolts securing the valve plate mounting brackets and remove the assembly from the bulkhead.

100 Any sensors not previously accessible can now be removed from the valve plate.

#### Refitting

101 Refitting is a reversal of removal, but ensure that the labelled vacuum hoses are connected to the correct pipe stub.

## 13 Cruise control system - general information

4D

A cruise control system is available as standard or optional equipment on certain V6 engine models. The system uses electro-mechanical devices to accurately maintain the vehicle road speed without the use of the accelerator pedal.

The system is controlled by an electronic control unit (ECU) which responds to inputs from the master and set/resume switches, the



12.98 Pull the vacuum hoses off the pipe stubs



vehicle speed sensor, the clutch and brake pedal switches and the shift control switch on the transmission. When the system is engaged, the ECU sends signals to the cruise control actuator which regulates the accelerator pedal position by means of a stepper motor and connecting cable. Once the driver has initiated the system, the road speed will be constantly monitored and maintained by the cruise control actuator.

The system can be disengaged at any time either by use of the control switches or by depressing the brake (and where applicable the clutch) pedals, or moving the automatic transmission gear selector to neutral. The ECU memory stores the previously set road speed which can be re-engaged by use of the resume switch.

## 14 Cruise control system components - removal and refitting



### Cruise control actuator

#### Removal

- 1 Disconnect the wiring multiplug from the actuator stepper motor (see illustration).
- 2 Disconnect the vacuum and vent hoses from the actuator.
- 3 Slacken the locknuts on the operating cable at the support bracket on the actuator.
- 4 Release the rubber boot and disconnect the inner cable from the actuator rod.
- 5 Undo the two mounting bolts securing the actuator bracket to the body; remove the actuator and bracket from the engine compartment.
- 6 If necessary, the mounting brackets and solenoid valves can now be removed from the actuator.

#### Refitting

- 7 Refitting is a reversal of removal, but adjust the operating cable as described in the following sub-Section on completion.

### Operating cable

#### Removal

- 8 Slacken the outer cable locknuts at the support bracket on the cruise control actuator.
- 9 Release the rubber boot and disconnect the inner cable from the actuator rod.
- 10 From inside the car, release the turnbuckles and lift out the trim panel over the clutch, brake and accelerator pedals.
- 11 Disconnect the inner cable from the accelerator pedal.
- 12 Release the cable from the engine

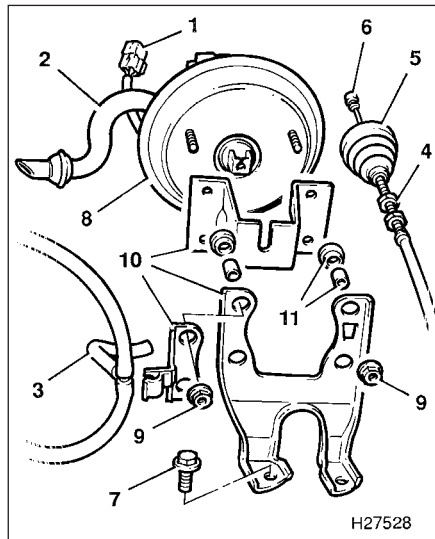

14.1 Cruise control actuator attachment details

- 1 Stepper motor wiring multiplug
- 2 Vent hose
- 3 Vacuum hose
- 4 Outer operating cable locknuts
- 5 Rubber boot
- 6 Inner operating cable
- 7 Actuator bracket mounting bolts
- 8 Actuator
- 9 Actuator to bracket mounting nuts
- 10 Bracket components
- 11 Bushes and sleeves

compartment bulkhead, and the support clips, and withdraw the cable from the car.

#### Refitting and adjustment

- 13 Refit the cable using a reversal of removal then adjust it as follows.
- 14 First check that the accelerator cable is correctly adjusted as described in Section 3.
- 15 Start the engine and allow it to idle.
- 16 Release the rubber boot at the actuator rod.
- 17 Push the actuator rod in, and measure the movement until the engine speed just begins to rise.
- 18 Adjust the position of the outer cable, by means of the locknuts, so that there is 9.5 to 12.5 mm of actuator rod movement before the engine speed increases off idle.
- 19 Tighten the locknuts and refit the rubber boot on completion.

### Cruise control switches

#### Main facia switch

- 20 The procedure for removal and refitting of the main switch is described in Chapter 12, Section 4.

#### Set/resume switch

- 21 Refer to Chapter 10, Section 18 and remove the steering wheel pad or the airbag module as applicable.
- 22 Disconnect the switch wiring multiplug and the two Lucar connectors at the steering wheel.
- 23 On early models, release the switch unit from the steering wheel pad. On later models, undo the two switch retaining screws and the single mounting bracket-to-steering wheel retaining bolt.
- 24 Remove the mounting bracket and withdraw the switch from the steering wheel.
- 25 Refit the switch using a reversal of removal then refit the steering wheel pad or airbag module as described in Chapter 10.

#### Clutch and brake switches

- 26 To remove the clutch switch, release the turnbuckles and lift out the trim panel over the clutch, brake and accelerator pedals.
- 27 Disconnect the switch wiring multiplug.
- 28 Slacken the locknut and unscrew the switch from the pedal bracket.
- 29 Refit the switch by screwing it in until the plunger is fully depressed, then tighten the locknut.
- 30 Reconnect the multiplug and refit trim panels.
- 31 The brake switch is combined with the stop-light switch and reference should be made to Chapter 9, Section 21.

### Electronic control unit

#### Removal

- 32 Release the turnbuckles and lift out the trim panel over the clutch, brake and accelerator pedals.
- 33 Disconnect the ECU multiplug, undo the retaining bolt and withdraw the ECU from its location on the door pillar bracket.

#### Refitting

- 34 Refitting is a reversal of removal.

## 15 Exhaust system - general information and component renewal

With the exception of the twin downpipes, the exhaust system is the same as used on 4-cylinder engines. Refer to Part A, Section 13 for exhaust system details, and to Part E, Section 3, for information on the catalytic converter.







# Chapter 4 Part E: Fuel and exhaust systems – Emissions control systems

## Contents

Catalytic converter - general information and precautions . . . . .	3	Exhaust system check . . . . .	See Chapter 1
General information . . . . .	1	Positive Crankcase Ventilation (PCV) system check and filter cleaning . . . . .	See Chapter 1
Emissions control systems - testing and component renewal . . . . .	2	Underbonnet check for fluid leaks and hose condition . . . . .	See Chapter 1
Engine compartment wiring check . . . . .	See Chapter 1		

## Degrees of difficulty

<b>Easy</b> , suitable for novice with little experience 	<b>Fairly easy</b> , suitable for beginner with some experience 	<b>Fairly difficult</b> , suitable for competent DIY mechanic 	<b>Difficult</b> , suitable for experienced DIY mechanic 	<b>Very difficult</b> , suitable for expert DIY or professional 
---	--	--	---	--

## Specifications

### Torque wrench settings

	Nm	lbf ft
Oxygen sensor:		
4-cylinder engines with sensor in front pipe . . . . .	20	15
4-cylinder engines with sensor in manifold . . . . .	55	41
V6 engines . . . . .	45	33
Air suction valve pipe nuts . . . . .	22	16
Air suction valve pipe bolts . . . . .	12	9
EGR valve nuts and bolts . . . . .	22	16

### 1 General information

1 To minimise pollution of the atmosphere from incompletely-burned and evaporating gases, and to maintain good driveability and fuel economy, a number of emissions control systems are used on later vehicles covered by this manual. They include the following:

- The engine management system (comprising both fuel and ignition sub-systems) itself.*
- Crankcase emissions control.*
- Evaporative emissions control system.*
- Exhaust emissions control (air injection system, exhaust gas recirculation system, catalytic converter).*

2 Before assuming an emission control system is malfunctioning, check the fuel and ignition systems carefully (see the earlier Parts of this Chapter, and Chapter 5). The diagnosis of most emission control devices requires specialised tools, equipment and training. If checking and servicing become too difficult, or if a procedure is beyond the scope of your skills, consult your Rover dealer or other specialist. **Note:** *The most frequent cause of emissions problems is simply a loose or broken electrical connector or vacuum hose, so always check the electrical connectors and vacuum hoses first.*

3 Pay close attention to any special precautions outlined in this Chapter. It should be noted that the illustrations of the various systems may not exactly match the system installed on your vehicle, due to changes made by the manufacturer during production or from year-to-year.

#### **Crankcase emissions control**

4 To reduce the emissions of unburned hydrocarbons from the crankcase into the atmosphere, a Positive Crankcase Ventilation (PCV) system is used whereby the engine is sealed and the blow-by gasses and oil vapour are drawn from inside the crankcase, through an oil separator, into the inlet tract to be burned by the engine during normal combustion.

5 Under conditions of high manifold depression (idling, deceleration) the gasses will be sucked positively out of the crankcase. Under conditions of low manifold depression (acceleration, full-throttle running) the gasses are forced out of the crankcase by the (relatively) higher crankcase pressure; if the engine is worn, the raised crankcase pressure (due to increased blow-by) will cause some of the flow to return under all manifold conditions.

#### **Evaporative emissions control**

6 To minimise the escape into the atmosphere of unburned hydrocarbons, an evaporative emissions control system is fitted

to models equipped with a catalytic converter. The fuel tank filler cap and vents are sealed and a charcoal canister is mounted in the engine compartment to collect the petrol vapours generated in the tank when the car is parked. It stores them until they can be cleared from the canister via the purge valve into the inlet tract, to be burned by the engine during normal combustion.

7 To ensure that the engine runs correctly when it is cold and/or idling, and to protect the catalytic converter from the effects of an over-rich mixture, the purge valve is not allowed to open until the engine has warmed-up, and is under load; the valve is then opened to allow the stored vapour to pass into the inlet tract.

8 On 4-cylinder engines the vacuum supply to operate the purge valve is regulated by a purge control valve solenoid which itself is under the control of the ECU. The solenoid is mounted either separately within the engine compartment or, on later models, directly on top of the charcoal canister.

9 On V6 engines the vacuum supply to the purge valve is regulated by the constant vacuum control valve (under ECU control) and by a thermostatic valve which is opened or closed depending on coolant temperature.

#### **Exhaust emissions control**

10 To minimise the amount of pollutants which escape into the atmosphere, some models are fitted with a catalytic converter in

the exhaust system. On all models where a catalytic converter is fitted, the system is of the closed-loop type, in which an oxygen sensor in the exhaust system provides the fuel injection/ignition system ECU with constant feedback on the oxygen content of the exhaust gasses. This enables the ECU to adjust the mixture by altering injector opening time, to provide the best possible conditions for the converter to operate.

**11** The oxygen sensor has a built-in heating element, controlled by the ECU to quickly bring the sensor's tip to an efficient operating temperature. The sensor's tip is sensitive to oxygen, and sends the ECU a varying voltage depending on the amount of oxygen in the exhaust gasses; if the intake air/fuel mixture is too rich, the exhaust gasses are low in oxygen, so the sensor sends a voltage signal proportional to the oxygen detected, the voltage altering as the mixture weakens and the amount of oxygen in the exhaust gasses rises. Peak conversion efficiency of all major pollutants occurs if the intake air/fuel mixture is maintained at the chemically-correct ratio for complete combustion of petrol - 14.7 parts (by weight) of air to 1 part of fuel (the "stoichiometric" ratio). The sensor output voltage alters in a large step at this point, the ECU using the signal change as a reference point, and correcting the intake air/fuel mixture accordingly, by altering the fuel injector opening time.

**12** To further improve emissions performance, later V6 engines are fitted with an air injection system and an exhaust gas recirculation (EGR) system. The air injection system operates by introducing fresh air from the air cleaner into the exhaust manifold under the control of the fuel/ignition ECU, and an air suction valve. The EGR system recirculates a proportion of the exhaust gasses through the EGR valve and back into the combustion chambers via the inlet manifold. Operation of

the system is controlled by the fuel/ignition ECU which opens and closes the EGR valve according to operating conditions.

**2 Emissions control systems - testing and component renewal**



**Crankcase emissions control**

**1** The checking and testing procedures for the PCV system are contained in Chapter 1.

**Evaporative emissions control**

**Testing**

**2** If the system is thought to be faulty, disconnect the hoses from the charcoal canister and purge valve, and check that they are clear by blowing through them. If the purge control valve, purge control valve solenoid or charcoal canister are thought to be faulty, they must be renewed. Testing of the control side of the system should be entrusted to a dealer with the dedicated test equipment necessary to interrogate the system quickly and accurately.

**Charcoal canister - renewal**

**3** If the purge control valve solenoid is located on top of the canister, disconnect it's wiring multiplug.

**4** Release the clips and disconnect the hoses from the top of the canister. Note their locations for correct refitting, and pull the hoses straight off the pipe stubs, otherwise the stubs may break off inside the hose (see illustration).

**5** Where fitted, release the securing strap and lift the canister from its location. On early models, disconnect the additional hose at the base of the canister.

**6** Refitting is a reversal of removal, ensuring that the hoses are correctly fitted.

**Purge control valve solenoid (early 4-cylinder engines) - renewal**

**7** Disconnect the wiring multiplug from the solenoid (see illustration).

**8** Release the clip and disconnect the vacuum hose from the solenoid. Pull the hose straight off the pipe stub otherwise the stub may break off inside the hose.

**9** Extract the circlip from the purge hose at the base of the solenoid and pull off the hose. Recover the O-ring from the pipe stub, ensuring that it doesn't remain in the hose.

**10** Slide the solenoid from its bracket and remove it from the car.

**11** Refitting is a reversal of removal, but use a new O-ring on the purge hose stub.

**Purge control valve solenoid (later 4-cylinder engines) - renewal**

**12** Disconnect the wiring multiplug from the solenoid.

**13** Release the clip and disconnect the vacuum hose from the solenoid. Pull the hose straight off the pipe stub otherwise the stub may break off inside the hose.

**14** Compress the retaining tags and withdraw the solenoid from the charcoal canister. Recover the O-ring from the base of the solenoid.

**15** Refitting is a reversal of removal, but use a new sealing O-ring.

**Thermostatic valve (V6 engines) - renewal**

**16** Drain the cooling system as described in Chapter 1.

**17** Refer to Part D, Section 12, and remove the fast idle valve.

**18** Disconnect the two vacuum hoses at the

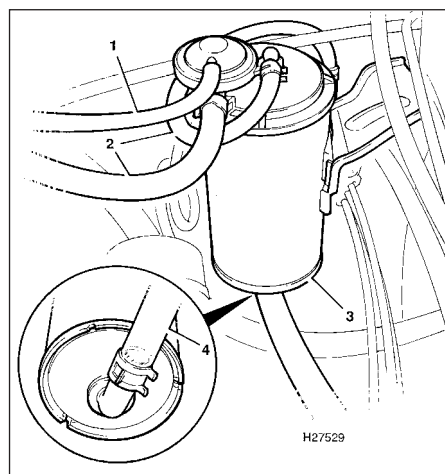

**2.4 Charcoal canister attachments on V6 engines**

- 1 Vacuum hose
- 2 Vapour hoses
- 3 Canister
- 4 Air inlet hose

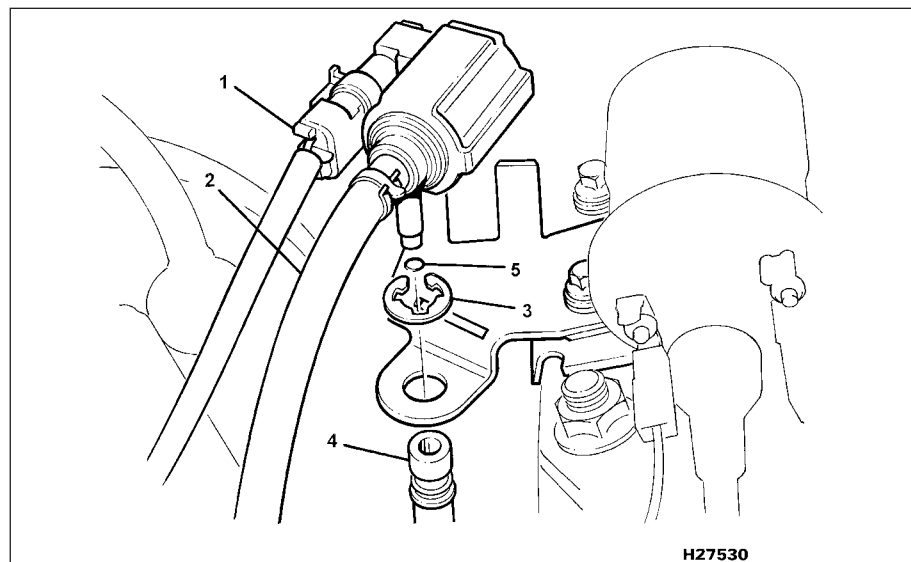

**2.7 Purge control valve solenoid attachments on early 4-cylinder engines**

- 1 Wiring multiplug
- 2 Vacuum hose
- 3 Purge hose circlip
- 4 Purge hose
- 5 O-ring



2.18 Disconnect the two vacuum hoses at the thermostatic valve (arrowed)

thermostatic valve and release the upper hose from its support clip (see illustration).

19 Unscrew the thermostatic valve from the coolant passage and remove it from the engine.

20 Refitting is a reversal of removal, but apply a thread sealant to the valve threads prior to refitting.

#### Constant vacuum control valve (V6 engines) - renewal

21 The constant vacuum control valve is located in the control box mounted on the engine compartment bulkhead. Further information on the control box and its components can be found in Part D, Section 12.

#### Exhaust emissions control

##### Testing

22 Many of the exhaust emissions control components are an integral part of the engine management system, and testing can only be accurately carried out using Rover test equipment. On V6 engines, any system faults will be stored in the ECU self-diagnosis memory and displayed as a series of flashing fault codes on the LED display. These can be quickly interpreted by a dealer to isolate the location of the fault and save time-consuming individual component testing.

23 If a component is known to be faulty, or if fault diagnosis has been carried out by a dealer, it can then be renewed as follows.

#### Oxygen sensor (4-cylinder engines) - renewal

**Note:** The oxygen sensor is delicate, and will not work if it is dropped or knocked, if its power supply is disrupted, or if any cleaning materials are used on it.

24 On models with Lucas multi-point fuel injection, the sensor is located on top of the exhaust downpipe, under the car.

25 Disconnect the sensor wiring harness multiplug at the connector in the engine compartment. Release the harness from the engine compartment cable ties and note the harness routing.

26 Jack up the front of the car and securely support it on axle stands.

27 Release the wiring harness from the underbody cable ties.

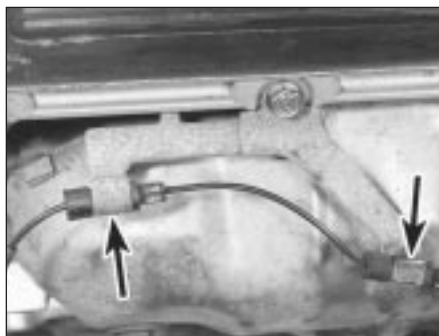

2.37 Release the oxygen sensor lead from the support bracket clips (arrowed)

28 Unscrew the sensor from the exhaust pipe and collect the sealing washer.

29 Refitting is a reversal of removal using a new sealing washer. Prior to installing the sensor, apply a smear of high temperature grease to the sensor threads. Ensure that the sensor is securely tightened and make sure that the wiring is routed correctly with no danger of it contacting either the exhaust system or engine.

30 On models with MEMS multi-point fuel injection, the sensor is located in the exhaust manifold.

31 Release the wiring harness from its support bracket on the thermostat housing and disconnect the harness multiplug.

32 Unscrew the sensor from the exhaust manifold and collect the sealing washer.

33 Refitting is a reversal of removal using a new sealing washer. Prior to installing the sensor, apply a smear of high temperature grease to the sensor threads and ensure that the sensor is securely tightened.

#### Front oxygen sensor (V6 engines) - renewal

34 Refer to the note at the beginning of paragraph 24 before proceeding.

35 Refer to Chapter 3, and remove the radiator.

36 Undo the three bolts securing the heat shield to the exhaust manifold.

37 Disconnect the sensor lead at the wiring connector and release the lead from the support bracket clips (see illustration).



2.45 Disconnect the brake servo vacuum hose (arrowed) from the inlet manifold



2.42 Rear oxygen sensor location in the exhaust manifold

38 Remove the heat shield and unscrew the sensor from the manifold.

39 Refitting is a reversal of removal using a new sealing washer. Prior to installing the sensor, apply a smear of high temperature grease to the sensor threads and ensure that the sensor is securely tightened. Refit the radiator as described in Chapter 3.

#### Rear oxygen sensor (V6 engines) - renewal

40 Refer to the note at the beginning of paragraph 24 before proceeding.

41 Jack up the front of the car and securely support it on axle stands.

42 From under the car, disconnect the sensor lead at the wiring connector and unscrew the sensor from the manifold (see illustration).

43 Refitting is a reversal of removal using a new sealing washer. Prior to installing the sensor, apply a smear of high temperature grease to the sensor threads and ensure that the sensor is securely tightened.

#### Air suction valve (V6 engines) - renewal

44 Disconnect the battery negative (earth) lead (refer to Chapter 5, Section 1).

45 Release the clip and disconnect the brake servo vacuum hose from the inlet manifold (see illustration).

46 Undo the bolt securing the pipe bracket at the rear of the air suction valve.

47 Disconnect the air suction valve vacuum hose (see illustration).

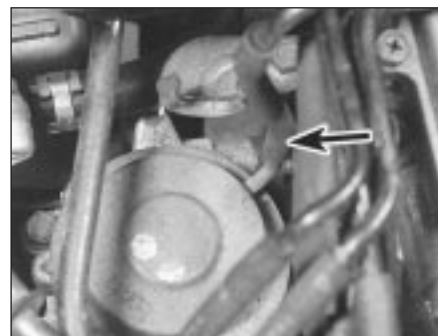

2.47 Disconnect the air suction valve vacuum hose (arrowed)





**2.56 Undo the two nuts from the suction valve pipe front flange and release the heat shield**

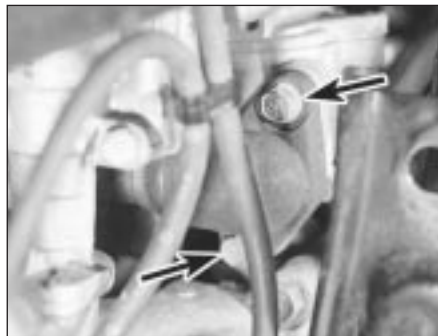

**2.57 Undo the two bolts (arrowed) at the suction valve pipe rear flange**

**48** Undo the two air suction pipe retaining bolts

**49** Undo the two bolts securing the fuel pipe retaining clips adjacent to the air suction valve.

**50** Relieve the fuel system pressure as described in Part D, Section 5.

**51** Undo the two banjo union bolts securing the fuel pipes to the front fuel rail. Release the pipes and collect the copper washers. Cover the open unions after disconnection then move the pipes away.

**52** Undo the vacuum pipe cluster support bracket bolt and move the pipes slightly for access to the air suction valve.

**53** Undo the three bolts and withdraw the air suction valve from the manifold. Recover the gasket.

**54** Refitting is a reversal of removal. Clean the mating faces prior to refitting and use a new gasket.

#### **Air suction valve pipe (V6 engines) - renewal**

**55** Remove the throttle body and the electronic idle control valve as described in Part D, Section 12.

**56** Undo the two nuts from the suction valve pipe front flange and release the heat shield (see illustration).

**57** Undo the two bolts at the suction valve pipe rear flange (see illustration).

**58** Disconnect the lead from the thermal transmitter and release the lead from its clip.

**59** Release the air suction pipe flanges and remove the pipe from the engine. Recover the two flange gaskets.

**60** Refitting is a reversal of removal. Clean the valve flange and manifold mating faces prior to refitting and use a new gasket.

#### **EGR valve and filter (V6 engines) - renewal**

**61** Remove the air intake trunking and air cleaner assembly as described in Part D, Section 2.

**62** Disconnect the EGR valve multiplug and release the multiplug from its bracket.

**63** Disconnect the vacuum hose at the valve.

**64** Undo the two nuts and remove the EGR valve from the filter housing (see illustration). Recover the flange gasket.

**65** Undo the two filter housing retaining bolts and remove the housing from the cylinder head. Recover the flange gasket and remove the filter from the housing.

**66** Clean the valve core and body using compressed air and a small screwdriver. Take care not to actuate the valve while holding it.

**67** Refitting is a reversal of removal. Fit a new filter during reassembly and use new gaskets at the mating faces.

### **3 Catalytic converter - general information and precautions**

**1** The catalytic converter is a reliable and simple device, which needs no maintenance in itself, but there are some facts of which an owner should be aware if the converter is to function properly for its full service life.

- (a) *DO NOT use leaded petrol in a vehicle equipped with a catalytic converter - the lead will coat the precious metals, reducing their converting efficiency, and will eventually destroy the converter.*
- (b) *Always keep the ignition and fuel systems well-maintained in accordance with the manufacturer's schedule (see Chapter 1).*
- (c) *If the engine develops a misfire, do not drive the vehicle at all (or at least as little as possible) until the fault is cured.*
- (d) *DO NOT push- or tow-start the vehicle - this will soak the catalytic converter in unburned fuel, causing it to overheat when the engine does start.*
- (e) *DO NOT switch off the ignition at high engine speeds, ie do not "blip" the throttle immediately before switching off.*

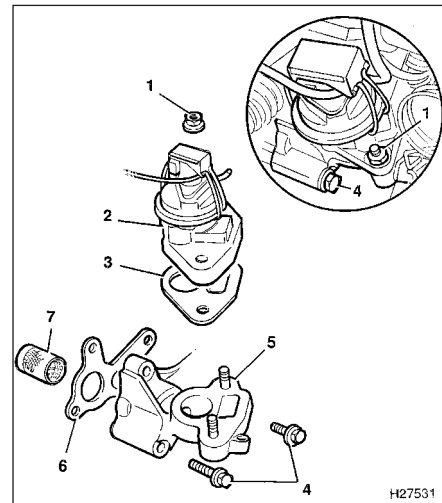

**2.64 EGR valve and filter components**

- |                        |                        |
|------------------------|------------------------|
| 1 Valve retaining nuts | 4 Filter housing bolts |
| 2 EGR valve            | 5 Filter housing       |
| 3 Gasket               | 6 Gasket               |
|                        | 7 Filter               |

- (f) *DO NOT use fuel or engine oil additives - these may contain substances harmful to the catalytic converter.*
  - (g) *DO NOT continue to use the vehicle if the engine burns oil to the extent of leaving a visible trail of blue smoke.*
  - (h) *Remember that the catalytic converter operates at very high temperatures. DO NOT, therefore, park the vehicle in dry undergrowth, over long grass or piles of dead leaves, after a long run.*
  - (i) *Remember that the catalytic converter is FRAGILE. Do not strike it with tools during servicing work.*
  - (j) *In some cases, a sulphurous smell (like that of rotten eggs) may be noticed from the exhaust. This is common to many catalytic converter-equipped vehicles. Once the vehicle has covered a few thousand miles, the problem should disappear - in the meantime, try changing the brand of petrol used.*
  - (k) *The catalytic converter used on a well-maintained and well-driven vehicle should last for between 50 000 and 100 000 miles. If the converter is no longer effective, it must be renewed.*
- 2** The catalytic converter is located between the exhaust system front and intermediate sections and is removed and refitted in the same way as the other sections. Always renew the converter flange seals when the unit is disturbed in any way, and ensure that all retaining nuts are securely tightened. Refer to the relevant earlier Parts of this Chapter, for details of exhaust system removal and refitting.







# Chapter 5

## Engine electrical systems

### Contents

Alternator - removal and refitting . . . . .	17	General information, precautions and battery disconnection . . . . .	1
Alternator brushes and voltage regulator - inspection and renewal . . . . .	18	Igniter (V6 engines) - removal and refitting . . . . .	8
Auxiliary drivebelts check and renewal . . . . .	See Chapter 1	Ignition coil - testing, removal and refitting . . . . .	7
Battery - removal and refitting . . . . .	2	Ignition system - general information and precautions . . . . .	3
Battery check, maintenance and charging . . . . .	See Chapter 1	Ignition system - testing . . . . .	4
Charging system - general information and precautions . . . . .	15	Ignition timing - adjustment . . . . .	10
Charging system - testing . . . . .	16	Ignition timing sensor/adjuster (V6 engines) - removal and refitting . . . . .	9
Crank/cylinder sensor - removal and refitting . . . . .	14	Knock sensor - removal and refitting . . . . .	12
Crankshaft sensor - removal and refitting . . . . .	13	Spark plug renewal and HT lead check . . . . .	See Chapter 1
Distributor (V6 engines) - removal and refitting . . . . .	6	Starter motor - brush renewal . . . . .	22
Distributor cap and rotor arm - removal and refitting . . . . .	5	Starter motor - removal and refitting . . . . .	21
Electronic control unit - removal and refitting . . . . .	11	Starting system - general information and precautions . . . . .	19
Engine compartment wiring check . . . . .	See Chapter 1	Starting system - testing . . . . .	20

### Degrees of difficulty

<b>Easy</b> , suitable for novice with little experience 	<b>Fairly easy</b> , suitable for beginner with some experience 	<b>Fairly difficult</b> , suitable for competent DIY mechanic 	<b>Difficult</b> , suitable for experienced DIY mechanic 	<b>Very difficult</b> , suitable for expert DIY or professional 
---	--	--	---	--

### Specifications

#### Battery

Type . . . . .	Lead-acid, maintenance-free
Rating - Cold cranking/Reserve capacity . . . . .	480 A/90 RC, 570 A/110 RC, 520 A/120 RC

#### Ignition coil

4-cylinder engines:	
Primary resistance at 20°C (68°F) . . . . .	0.71 to 0.81 ohms
Current consumption - engine idling . . . . .	0.25 to 0.75 amps
V6 engines:	
Primary/secondary resistance at 20°C (68°F) - see text:	
Between terminals C and D . . . . .	0.35 to 0.42 ohms
Between terminals B and D . . . . .	2.1 to 2.3 kohms
Between terminals A and HT terminal (manual transmission) . . . . .	9.0 to 13.5 kohms
Between terminals A and HT terminal (automatic transmission) . . . . .	14.0 to 21.6 kohms

#### Ignition timing

2.5 litre engines (at idle speed, vacuum connected)*:	
Manual transmission:	
Unleaded fuel . . . . .	9° ± 2°
Leaded fuel . . . . .	13° ± 2°
Automatic transmission:	
Unleaded fuel . . . . .	7° ± 2°
Leaded fuel . . . . .	11° ± 2°
2.7 litre engines (at idle speed)*:	
Unleaded fuel . . . . .	11° ± 2°
Leaded fuel . . . . .	15° ± 2°

\* **Note:** The ignition timing is only adjustable on the non-catalyst equipped V6 engines shown. On all other engines, ignition timing is controlled by the fuel or ignition ECU and is not adjustable.

#### Firing order

4-cylinder engines . . . . .	1-3-4-2 (No 1 cylinder at crankshaft pulley end)
V6 engines . . . . .	1-4-2-5-3-6 (No 1 cylinder at crankshaft pulley end of rear cylinder head)

### Alternator

Type:	
4-cylinder engines	Lucas/Magneti-Marelli A127, A133 or A1271
V6 engines	Nippondenso CGK 46
Brush length (nominal):	
New	20.0 mm
Minimum	10.0 mm

### Starter motor

Type:	
4-cylinder engines	Lucas/Magneti-Marelli M78R or M79
V6 engines	Nippondenso DR 5U1
Minimum brush length (nominal):	8.0 mm

### Torque wrench settings

	Nm	lbf ft
4-cylinder engines:		
Ignition coil bracket bolts	24	18
Knock sensor	12	9
Crankshaft sensor bolts	6	4
Alternator pivot and mounting bolts	25	18
Alternator adjustment bracket bolts	12	9
Starter motor bolts:		
Manual transmission	85	63
Automatic transmission	45	33
V6 engines:		
Alternator side pivot bolt	45	33
Alternator lower mounting nut	24	18
Starter motor bolts	45	33

## 1 General information, precautions and battery disconnection

### General information

The engine electrical systems include all ignition, charging and starting components. Because of their engine-related functions, these components are discussed separately from body electrical devices such as the lights, the instruments, etc (which are included in Chapter 12).

### Precautions

Always observe the following precautions when working on the electrical system:

- Be extremely careful when servicing engine electrical components. They are easily damaged if checked, connected or handled improperly.
- Never leave the ignition switched on for long periods of time when the engine is not running.
- Don't disconnect the battery leads while the engine is running.
- Maintain correct polarity when connecting a battery lead from another vehicle during jump starting - see the "Jump starting" section at the front of this manual.
- Always disconnect the negative lead first, and reconnect it last, or the battery may be shorted by the tool being used to loosen the lead clamps.

It's also a good idea to review the safety-related information regarding the engine electrical systems located in the "Safety first!" section at the front of this manual, before

beginning any operation included in this Chapter.

### Battery disconnection

Several systems fitted to many of the cars covered by this manual require battery power to be available at all times, either to ensure their continued operation or to maintain control unit memories (such as those used to control the seat and mirror positions, the operation of the electric windows and sun roof, and the retention of the radio/cassette and CD player security codes). Additionally, on engines with single-point fuel injection, the idle mixture settings stored in the fuel system ECU will also be lost when the battery is disconnected. Whenever the battery is to be disconnected therefore, first note the following, to ensure that there are no unforeseen consequences of this action:

- First, on any vehicle with central locking, it is a wise precaution to remove the key from the ignition, and to keep it with you, so that it does not get locked in if the central locking should engage accidentally when the battery is reconnected!
- If the battery is disconnected while the alarm system is armed or activated, the alarm will remain in the same state when the battery is reconnected.
- As mentioned above, on cars equipped with single-point fuel injection, the idle mixture settings stored in the memory of the fuel system electronic control unit will be lost whenever the battery is disconnected. When the battery is reconnected, the control unit will adopt a set of nominal parameters which will allow

the engine to run, but the mixture setting will be outside the manufacturer's specification. Should the engine performance be unsatisfactory, the control unit can be calibrated as a temporary measure using the procedure described in Chapter 4, Part A, Section 11, until such time as, the setting can be accurately adjusted by a dealer.

- Recalibration procedures for the seat and mirror position memory, the electric sun roof and window memories, and the "lazy locking" memories on models so equipped are provided in Chapter 11, Section 1.
- If a Rover original equipment radio/cassette player or CD player is fitted, and the unit and/or the battery is disconnected, the unit will not function again on reconnection until the correct security code is entered. Details of this procedure, which varies according to the unit and model year, are given in the Rover "In-car entertainment" booklet supplied with the vehicle when new. Ensure you have the correct code before you disconnect the battery. For obvious security reasons, the procedure is not given in this manual. If you do not have the code or details of the correct procedure, but can supply proof of ownership and a legitimate reason for wanting this information, the vehicle's selling dealer may be able to help.

Devices known as "memory-savers" (or "code-savers") can be used to avoid some of the above problems. Precise details vary according to the device used. Typically, it is plugged into the cigarette lighter, and is

connected by its own wires to a spare battery; the vehicle's own battery is then disconnected from the electrical system, leaving the "memory-saver" to pass sufficient current to maintain audio unit security codes and ECU memory values, and also to run permanently-live circuits such as the clock, all the while isolating the battery in the event of a short-circuit occurring while work is carried out. Before using any of these devices, seek the advice of a Rover dealer as to their suitability for use on your car.



**Warning:** Some of these devices allow a considerable amount of current to pass, which can mean that many of the vehicle's

systems are still operational when the main battery is disconnected. If a "memory-saver" is used, ensure that the circuit concerned is actually "dead" before carrying out any work on it!

## 2 Battery - removal and refitting



**Note:** Refer to the previous Section before proceeding and also the relevant Sections of Chapter 1.

### Removal

- 1 The "sealed for life" battery is located on the left-hand side of the engine compartment.
- 2 Slacken the negative (-) terminal clamp bolt and lift the terminal off the battery post.
- 3 Lift the plastic cover from the positive (+) terminal, slacken the clamp bolt and lift the terminal off the battery post (see illustration).
- 4 Undo the retaining bolt and remove the battery clamp plate (see illustration).
- 5 Lift the battery from the tray keeping it upright and taking care not to touch any clothing. Be careful - it's heavy.
- 6 If required, the battery tray can be removed after undoing the three retaining bolts.
- 7 Clean the battery terminal posts, clamps and the battery casing. If the battery tray is rusted as a result of battery acid spilling onto it, clean it thoroughly and re-paint with reference to Chapter 1.
- 8 If you are renewing the battery, make sure that you get one that's identical, with the same dimensions, amperage rating, cold cranking rating, etc. Dispose of the old battery in a responsible fashion. Most local authorities have facilities for the collection and disposal of such items - batteries contain sulphuric acid and lead, and should not be simply thrown out with the household rubbish!

### Refitting

- 9 Refitting is a reversal of removal. Smear the battery terminals with a petroleum-based jelly prior to reconnecting. Always connect the positive terminal clamp first and the negative terminal clamp last.



2.3 Lift off the plastic cover for access to the battery positive terminal



2.4 Removing the battery clamp retaining bolt

## 3 Ignition system - general information and precautions

### General information

#### 4-cylinder engines

All 4-cylinder engine models covered by this manual are equipped with a programmed electronic ignition system, which utilizes computer technology and electro-magnetic circuitry to simulate the main functions of a conventional ignition distributor.

A reluctor ring on the periphery of the engine flywheel, and a crankshaft sensor whose inductive head runs between the reluctor ring teeth, replace the operation of the contact breaker points in a conventional system. The reluctor ring utilizes 34 teeth spaced at 10° intervals, with two spaces, 180° apart, corresponding to TDC for Nos 1 and 4 pistons, and Nos 2 and 3 pistons respectively. As the crankshaft rotates, the reluctor ring teeth pass over the crankshaft sensor, which transmits a pulse to the ignition or ignition/fuel electronic control unit (ECU) every time a tooth passes over it. The ECU recognises the absence of a pulse every 180°, and consequently establishes the TDC position. Each subsequent pulse then represents 10° of crankshaft rotation. This, and the time interval between pulses, allows the ECU to accurately determine crankshaft position and speed.

A small bore pipe connecting the inlet manifold to a pressure transducer within the ECU supplies the unit with information on engine load. From this constantly-changing data, the ECU selects a particular advance from a range of ignition characteristics stored in its memory. The basic setting can be further advanced or retarded, according to information sent to the ECU from the coolant temperature sensor, knock sensor and on certain models, from the throttle pedal switch.

With the firing point established, the ECU triggers the ignition coil, which delivers HT voltage to the spark plugs in the conventional manner. The cycle is then repeated many times a second for each cylinder in turn.

In addition to the above operations, many of the ignition system components have a second function in the control and operation of the fuel injection system. Further details will be found in the appropriate Part of Chapter 4.

#### V6 engines

On all V6 engines a breakerless electronic ignition system is used which comprises the distributor, an igniter unit and the ignition coil. The distributor is mounted on the left-hand end of the front cylinder head and is driven directly by the front camshaft. The ignition system forms part of the engine management package controlled by the fuel system electronic control unit (ECU).

The distributor contains a reluctor mounted on the distributor shaft, and a stator and pick-up coil mounted on the baseplate. On 2.5 litre engines the igniter unit is attached to the side of the distributor body, whereas on 2.7 litre engines it is mounted separately at the rear left-hand side of the engine compartment.

When the ignition is switched on, but the engine is stationary, the transistors in the igniter unit prevent current flowing through the ignition system primary (LT) circuit. As the crankshaft rotates, the reluctor moves through the magnetic field created by the stator. When the reluctor teeth are in alignment with the stator projections, a small AC voltage is created and sensed by the pick-up coil. The igniter uses this voltage to switch the transistors in the unit and completes the ignition system primary (LT) circuit.

As the reluctor teeth move out of alignment with the stator projections, the AC voltage changes and the transistors in the igniter are switched again to interrupt the primary (LT) circuit. This causes a high voltage to be induced in the coil secondary (HT) windings which then travels down the HT lead to the distributor and onto the relevant spark plug.

On 2.5 litre engines ignition advance is controlled by both centrifugal and vacuum operated systems. Centrifugal advance is controlled by engine speed whereas vacuum advance is controlled by the ignition control system. This system uses solenoid valves and sensors to apply vacuum to one of the two distributor vacuum diaphragms dependant on engine operating parameters. Sensors

## 5•4 Engine electrical systems

monitor manifold pressure, coolant temperature, intake air temperature, atmospheric pressure and engine speed and pass signals to the fuel system ECU. According to the signals received, the ECU controls the operation of the solenoid valves to provide the appropriate vacuum necessary to create the required ignition advance.

On 2.7 litre engines ignition advance is controlled entirely by the fuel system ECU. As with the 2.5 litre engines, sensors monitor engine parameters and send signals to the ECU accordingly. From the information received, the required ignition advance is determined by the ECU for all engine operating conditions. In addition to the sensors described for 2.5 litre engines, 2.7 litre models also utilise a crank/cylinder sensor, mounted just behind the front camshaft sprocket, to detect the TDC position for No 1 cylinder and to determine engine speed and piston position. An additional TDC sensor, mounted in the distributor, is used to provide a fixed ignition timing setting during engine cranking and as a back-up unit should the crank/cylinder sensor fail, or produce erroneous signals.

In addition to the above operations, many of the ignition system components have a second function in the control and operation of the fuel injection system. Further details will be found in the appropriate Part of Chapter 4.

### Precautions

When working on the ignition system, take the following precautions:

- (a) *Do not keep the ignition switched on for more than 10 seconds if the engine will not start.*
- (b) *If a separate tachometer is ever required for servicing work, consult a dealer service department before buying a tachometer for use with this vehicle - some tachometers may be incompatible with these types of ignition systems - and always connect it in accordance with the equipment manufacturer's instructions.*
- (c) *Never connect the ignition coil terminals to earth. This could result in damage to the coil and/or the ECU or igniter unit.*
- (d) *Do not disconnect the battery when the engine is running.*
- (e) *Refer to the warning at the beginning of the next Section concerning HT voltage.*

## 4 Ignition system - testing



**Warning:** Voltages produced by an electronic ignition system are considerably higher than those produced by conventional ignition systems. Extreme care must be taken when working on the system if the ignition is switched on. Persons with surgically implanted cardiac pacemaker devices should keep well clear of the ignition circuits, components and test equipment.

### General

**1** The components of the electronic ignition system are normally very reliable; most faults are far more likely to be due to loose or dirty connections, or to "tracking" of HT voltage due to dirt, dampness or damaged insulation, than to the failure of any of the system's components. **Always** check all wiring thoroughly before condemning an electrical component, and work methodically to eliminate all other possibilities before deciding that a particular component is faulty.

**2** The old practice of checking for a spark by holding the live end of an HT lead a short distance away from the engine is **not** recommended; not only is there a high risk of a powerful electric shock, but the HT coil, ECU or igniter unit may be damaged. Similarly, **never** try to "diagnose" misfires by pulling off one HT lead at a time.

### Engine will not start

**3** If the engine either will not turn over at all, or only turns very slowly, check the battery and starter motor. Connect a voltmeter across the battery terminals (meter positive probe to battery positive terminal) then note the voltage reading obtained while turning the engine over on the starter for (no more than) ten seconds. If the reading obtained is less than approximately 9.5 volts, first check the battery, starter motor and charging system as described in the relevant Sections of this Chapter.

**4** If the engine turns over at normal speed but will not start, check the HT circuit by connecting a timing light (following its manufacturer's instructions) and turning the engine over on the starter motor; if the light flashes, voltage is reaching the spark plugs, so these should be checked first. If the light does not flash, check the HT leads themselves, followed by the distributor cap, carbon brush and rotor arm, using the information given in Chapter 1.

**5** If there is a spark, check the fuel system for faults, referring to the relevant part of Chapter 4 for further information.

**6** If there is still no spark, check the condition of fuse 15 (early models) or fuse 19 (later models) in the passenger compartment fusebox. If the fuse is sound, check the voltage at the ignition coil "+" terminal (light green wire on V6 engines and early 4-cylinder engines, brown/pink wire on later 4-cylinder engines); it should be the same as the battery voltage (ie, at least 11.7 volts). If the voltage at the coil is more than 1 volt less than that at the battery, check the condition of all the circuit wiring, referring to the wiring diagrams at the end of this manual.

**7** If the feed to the coil is sound, check the coil's primary and secondary winding resistance as described later in Section 7. If faulty, a new coil should be fitted. However, check carefully the condition of the LT connections themselves before doing so, to

ensure that the fault is not due to dirty or poorly-fastened connectors.

**8** If the coil is in good condition, the fault is probably within the crankshaft sensor or the fuel or ignition ECU on 4-cylinder engines, or within the pick-up coil, igniter, or fuel ECU on V6 engines. Testing of these components should be entrusted to a Rover dealer.

### Engine misfires

**9** An irregular misfire suggests either a loose connection or intermittent fault on the primary circuit, or an HT fault on the coil side of the rotor arm.

**10** With the ignition switched off, check carefully through the system, ensuring that all connections are clean and securely fastened. If the equipment is available, check the LT circuit as described above.

**11** Check that the ignition coil, the distributor cap and the HT leads are clean and dry. Check the leads themselves and the spark plugs (by substitution if necessary), then check the distributor cap, carbon brush and rotor arm as described in Chapter 1.

**12** Regular misfiring is almost certainly due to a fault in the distributor cap, HT leads or spark plugs. Use a timing light (paragraph 4 above) to check whether HT voltage is present at all leads.

**13** If HT voltage is not present on any particular lead, the fault will be in that lead, or in the distributor cap. If HT is present on all leads, the fault will be in the spark plugs; check and renew them if there is any doubt about their condition.

**14** If no HT is present, check the ignition coil; its secondary windings may be breaking down under load.

## 5 Distributor cap and rotor arm - removal and refitting



### Removal

**1** Using an open-ended spanner, undo the two retaining screws and lift off the distributor cap from the cylinder head or distributor as applicable (see illustration). On V6 engines, recover the large O-ring seal from the base of



**5.1** Undo the two retaining screws and lift off the distributor cap



the cap. Clean and check the cap as described in Chapter 1.

2 If the cap is to be renewed, record the position of the HT leads in relation to the cap, then pull them off. Transfer the leads to a new cap, refitting them in the same position.

3 To remove the rotor arm, withdraw the plastic shield (where fitted), then undo the retaining grub screw using an Allen key (see illustrations). Withdraw the rotor arm from the end of the camshaft or distributor shaft.

### Refitting

4 Refitting the rotor arm, shield and distributor cap is a reversal of removal. Ensure that all traces of thread locking compound are removed from the rotor arm retaining grub screw and its threaded hole, then apply fresh thread locking compound, such as Loctite 222 or equivalent prior to refitting. Failure to remove all traces of old compound first, may cause seizure of the grub screw, making subsequent removal impossible.

## 6 Distributor (V6 engines) - removal and refitting

### 2.5 litre engines

#### Removal

1 Disconnect the battery negative (earth) lead (refer to Section 1 before doing this).

2 Using an open-ended spanner, undo the two retaining screws and lift off the distributor cap. Recover the large O-ring seal from the base of the cap.

3 Release the wiring multiplug and, where applicable, the EGR valve vacuum hose from the distributor support clips.

4 Mark the position of the vacuum hose connections at the distributor vacuum unit and disconnect the hoses.

5 Disconnect the distributor multiplug from the ignition coil and the lead from the radio condenser then release the wiring from the cable clips.



6.14 Undo the bolt (arrowed) and release the wiring harness from the side of the distributor body



5.3a Where fitted, withdraw the plastic shield . . .

6 Prise off the plastic cap from the bolt securing the distributor to the cylinder head.

7 Using a small punch or fine file, mark the position of the distributor base relative to the cylinder head.

8 Undo the distributor retaining bolt and withdraw the unit from the cylinder head. Recover the O-ring at the base of the distributor body.

#### Refitting

9 With the distributor located on the cylinder head, turn the rotor arm until the offset drive dog positively engages with the slot in the end of the camshaft, then push the distributor body fully home. Once in place, align the distributor body with the mark made on removal. The remainder of refitting is a reversal of removal. After installation, adjust the ignition timing as described in Section 10.

### 2.7 litre engines

#### Removal

10 Disconnect the battery negative (earth) lead (refer to Section 1 before doing this).

11 Using an open-ended spanner, undo the two retaining screws and lift off the distributor cap. Recover the large O-ring seal from the base of the cap.

12 Release the wiring multiplug and the EGR valve vacuum hoses from the distributor support clips.

13 Disconnect the distributor multiplug from the connector on the side of the distributor.



6.15a Undo the distributor retaining bolt . . .



5.3b . . . then undo the rotor arm grub screw

14 Undo the support clip bolt and release the harness from the side of the distributor body (see illustration).

15 Undo the distributor retaining bolt and withdraw the unit from the cylinder head (see illustrations). Recover the O-ring at the base of the distributor body.

#### Refitting

16 With the distributor located on the cylinder head, turn the rotor arm until the offset drive dog positively engages with the slot in the end of the camshaft, then push the distributor body fully home. The remainder of refitting is a reversal of removal.

## 7 Ignition coil - testing, removal and refitting

### Testing

1 The ignition coil is mounted on the left-hand side of the engine compartment, on the suspension strut tower.

2 Testing of the coil is carried out using an ohmmeter, or multi-meter set to its resistance function, to check the primary and secondary coil windings for continuity. Ensure that the ignition is switched off before carrying out the following checks.

3 On 4-cylinder engines disconnect the LT and HT wiring at the coil, and connect an ohmmeter across the positive and negative LT



6.15b . . . and withdraw the unit from the cylinder head

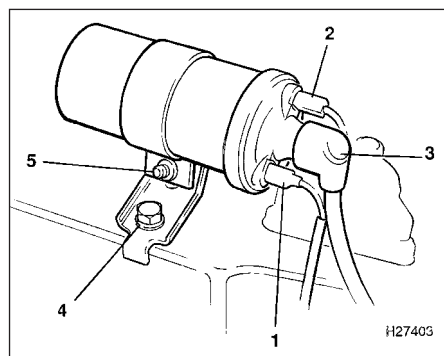

**7.3 Ignition coil connections and attachments on 4-cylinder engines**

- 1 LT negative lead
- 2 LT positive lead
- 3 HT lead
- 4 Mounting bracket retaining bolt
- 5 Coil-to-bracket retaining screw

terminals (see illustration). The primary winding resistance should be as given in the Specifications at the beginning of this Chapter. If the resistance is not as specified, the coil should be renewed.

4 On V6 engines, disconnect the wiring multiplug(s) and the distributor HT lead at the coil and connect an ohmmeter across the multiplug terminals as follows (see illustration).

Between terminals C and D.

Between terminals B and D.

Between terminal A and the HT terminal.

The resistances should be as given in the Specifications at the beginning of this Chapter. If the resistance is not as specified, the coil should be renewed.

5 If the coil is thought to be faulty, have your findings confirmed by a Rover dealer before renewing the coil.

**Removal**

6 To remove the coil, disconnect the LT leads or multipugs at the coil terminals, and the HT lead at the centre terminal.

7 Undo the mounting bracket retaining bolt(s) and remove the coil.

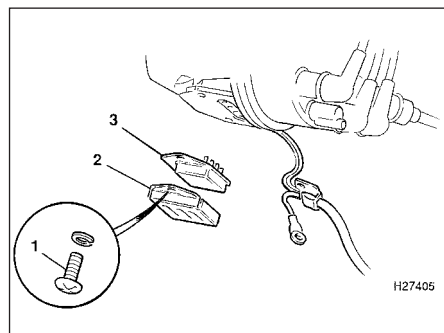

**8.2 Igniter component details on 2.5 litre engines**

- 1 Retaining screws
- 2 Igniter cover
- 3 Igniter

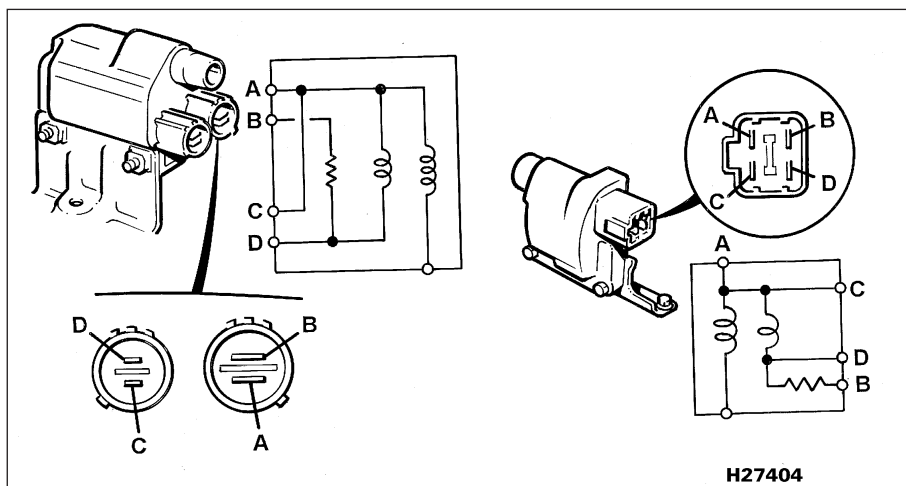

**7.4 Ignition coil connections and terminal identification on V6 engines**

Left-hand illustration - manual transmission

Right-hand illustration - automatic transmission

8 On 4-cylinder engines, note the position of the positive and negative terminals in relation to the mounting bracket, then slacken the mounting bracket screw and slide out the coil.

**Refitting**

9 Refitting is a reversal of removal.

**8 Igniter (V6 engines) - removal and refitting**

**2.5 litre engines**

**Removal**

1 Remove the distributor as described in Section 6.

2 Undo the two igniter cover securing screws on the side of the distributor body (see illustration).

3 Move the wiring aside and lift off the cover.

4 Carefully withdraw the igniter from its care on the side of the distributor.

**Refitting**

5 Thoroughly clean the mating faces of the igniter and distributor and apply a silicone grease to the distributor mating face.

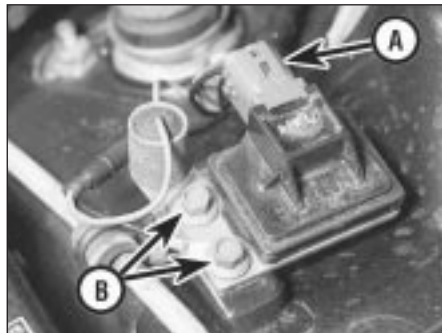

**8.8 Igniter multiplug (A) and retaining screws (B) on 2.7 litre engines**

6 Locate the igniter in position then refit the cover and the wiring clip.

7 Refit the distributor as described in Section 6, then adjust the ignition timing as described in Section 10.

**2.7 litre engines**

**Removal**

8 The igniter is located on the left-hand side of the engine compartment, behind the fusebox (see illustration).

9 Ensure that the ignition is switched off then disconnect the igniter wiring multiplug.

10 Undo the two retaining screws and withdraw the igniter from its mounting bracket.

**Refitting**

11 Refitting is a reversal of removal.

**9 Ignition timing sensor/adjuster (V6 engines) - removal and refitting**

**General**

1 The ignition timing sensor/adjuster is only fitted to 2.7 litre engines and is located in the control box mounted on the engine compartment bulkhead. On non-catalyst equipped engines, the ignition timing adjuster is used to alter the ignition timing to allow the engine to run on leaded or unleaded fuel. On catalyst equipped engines the ignition timing is not adjustable and the ignition timing sensor is used in a monitoring capacity by the fuel system ECU.

**Removal**

2 Disconnect the battery negative (earth) lead (refer to Section 1 before doing this).

3 Slacken the two bolts securing the control box to the bulkhead.



9.5 Wiring multiplug connections on the front of the control box

4 Undo the three screws and lift off the control box upper cover.

5 Release the wiring multiplugs from the mounting brackets on the front of the control box and disconnect them (see illustration). Note their connections for refitting.

6 Remove the control box lower cover from the valve plate assembly.

7 Undo the two screws securing the ignition timing adjuster to the valve plate and withdraw the adjuster from its location.

### Refitting

8 Refitting is a reversal of removal. On non-catalyst equipped engines, adjust the ignition timing as described in Section 10 on completion.

## 10 Ignition timing - adjustment



### General

1 The ignition timing is only adjustable on non-catalyst equipped V6 engines; on all other engines, ignition timing is controlled entirely by the fuel or ignition system ECU.

2 All the following adjustments require the use of a stroboscopic timing light. Additionally, if the adjustment is being carried out on 2.5 litre engines to allow the use of unleaded fuel, the timing light will need to be of the adjustable type which allows the unit to be pre-set to the actual ignition timing value. This is necessary because the timing marks provided on the crankshaft pulley are only applicable to leaded fuel adjustment. However, by using an adjustable timing light, the TDC mark on the pulley can be used instead.

### 2.5 litre engines

#### Adjustment for use with leaded fuel

3 Remove the access cover under the right-hand wheelarch.

4 Using a socket and bar on the crankshaft pulley bolt, rotate the crankshaft pulley, in the normal direction of rotation, until the timing marks are visible. Note that the timing marks

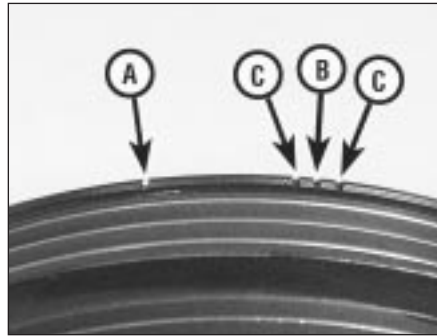

10.4 Timing mark identification on the crankshaft pulley

A TDC notch

B Ignition timing setting notch

C  $\pm 2^\circ$  tolerance notches

are four very small notches on the pulley inner rim and are easily missed. The first notch (usually coloured white) represents Top Dead Centre (TDC) for No 1 piston on compression. The next three notches are the actual timing marks. The centre notch of the three represents  $13^\circ$  BTDC (manual transmission) or  $11^\circ$  BTDC (automatic transmission). The remaining two notches represent a timing tolerance of  $\pm 2^\circ$  (see illustration).

5 Once the marks have been located, it is a good idea to highlight them, and the pointer on the timing belt cover, with a dab of quick-drying white paint to make them easily recognisable when using the timing light (see illustration).

6 Start the engine and allow it to warm up to normal operating temperature. Check that the idling speed is correct and, if necessary, adjust it as described in Chapter 1.

7 Switch the engine off and connect the timing light to No 1 cylinder plug lead as described in the timing light manufacturer's instructions. No 1 cylinder is on the rearmost cylinder at the crankshaft pulley end (beneath the brake master cylinder).

8 Start the engine again and allow it to idle. Point the timing light at the timing marks. The pointer on the timing belt cover should be aligned with the appropriate notch on the crankshaft pulley.

9 If adjustment is required, prise off the plastic cap from the bolt securing the distributor to the cylinder head, and slacken the bolt slightly. Rotate the distributor body clockwise to advance the timing, or anti-clockwise to retard it, until the pointer and pulley notch are aligned. Tighten the distributor securing bolt, recheck that the marks are still aligned, then refit the plastic cap.

10 Switch off the engine and disconnect the timing light. Refit the access cover under the wheelarch.

#### Adjustment for use with unleaded fuel

11 As mentioned at the beginning of this Section, an adjustable timing light will be required for this operation.



10.5 Highlight the pointer on the timing cover (arrowed) and the relevant pulley notch with white paint

12 Refer to paragraphs 3, 4 and 5 above and highlight the TDC notch on the pulley and the pointer on the timing belt cover. Note that the other three timing marks are not used in the following procedure and can be ignored.

13 Start the engine and allow it to warm up to normal operating temperature. Check that the idling speed is correct and, if necessary, adjust it as described in Chapter 1.

14 Switch the engine off and connect the timing light to No 1 cylinder plug lead as described in the timing light manufacturer's instructions. No 1 cylinder is on the rearmost cylinder at the crankshaft pulley end (beneath the brake master cylinder).

15 Refer to the Specifications at the beginning of this Chapter for the correct ignition timing setting. Set the timing light to this figure in accordance with the timing light manufacturer's instructions.

16 Start the engine again and allow it to idle. Point the timing light at the timing marks. The pointer on the timing belt cover should be aligned with the TDC notch on the crankshaft pulley.

17 If adjustment is required, prise off the plastic cap from the bolt securing the distributor to the cylinder head and slacken the bolt slightly. Rotate the distributor body clockwise to advance the timing, or anti-clockwise to retard it, until the pointer and pulley notch are aligned. Tighten the distributor securing bolt, recheck that the marks are still aligned, then refit the plastic cap.

18 Switch off the engine and disconnect the timing light. Refit the access cover under the wheelarch.

### 2.7 litre engines

19 Remove the access cover under the right-hand wheelarch.

20 Using a socket and bar on the crankshaft pulley bolt, rotate the crankshaft pulley, in the normal direction of rotation, until the timing marks are visible. Note that the timing marks are four very small notches on the pulley inner rim and are easily missed. The first notch (usually coloured white) represents Top Dead Centre (TDC) for No 1 piston on compression. The next three notches are the actual timing



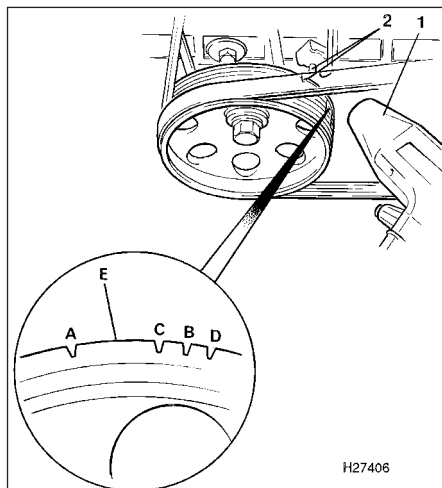

10.21 Ignition timing adjustment on 2.7 litre engines

- 1 Timing light
- 2 Timing cover pointer and TDC notch
- A Pulley TDC notch
- B 15° BTDC notch
- C 13° BTDC notch
- D 17° BTDC notch
- E New notch position (11° BTDC) for unleaded fuel setting

marks. The centre notch of the three (usually coloured red) represents 15° BTDC. The remaining two notches represent a timing tolerance of  $\pm 2^\circ$  (see illustration 10.4).

21 If the engine is being adjusted to run on unleaded fuel, it will be necessary to make an additional notch on the pulley (the existing notches are only applicable when adjusting for use with leaded fuel). To do this, measure the distance from notch C to notch B and make an additional notch E, that distance from C (see illustration). Use a small file to make the new notch.

22 Once the marks have been located, it is a good idea to highlight them, and the pointer on the timing belt cover, with a dab of quick-drying white paint to make them easily recognisable when using the timing light.

23 Start the engine and allow it to warm up to normal operating temperature. Check that the idling speed is correct and, if necessary, adjust it as described in Chapter 1.



11.2 Ignition ECU location on the engine compartment bulkhead



10.26 Undo the three screws and lift off the control box upper cover

24 Switch the engine off and connect the timing light to No 1 cylinder plug lead as described in the timing light manufacturer's instructions. No 1 cylinder is on the rearmost cylinder at the crankshaft pulley end (beneath the brake master cylinder).

25 Start the engine again and allow it to idle. Point the timing light at the timing marks. The pointer on the timing belt cover should be aligned with the appropriate notch on the crankshaft pulley.

26 If adjustment is required, slacken the two screws securing the control box to the engine compartment bulkhead. Undo the three screws and lift off the control box upper cover (see illustration).

27 Engage a small screwdriver with the adjustment slot in the ignition timing adjuster and turn the adjuster clockwise to advance the timing or anti-clockwise to retard it (see illustration).

28 Make a final check of the setting, then switch off the engine and disconnect the timing light. Refit the control box cover and the access cover under the wheelarch.

### 11 Electronic control unit - removal and refitting

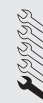

**Note:** The following procedure is applicable to 4-cylinder engines with multi-point fuel injection which use a separate ECU for the ignition system. For all other engines the ignition system is controlled by the fuel system ECU and reference should be made to the



10.27 Turn the ignition timing adjuster to advance or retard the timing

procedures contained in the relevant Parts of Chapter 4.

### Removal

1 Disconnect the battery negative (earth) lead (refer to Section 1 before doing this).

2 Disconnect the wiring multiplug from the ECU (located on the left-hand side of the engine compartment), either behind the battery or on the bulkhead (see illustration). To do this, press the retaining tab upwards, release the bottom of the multiplug, then disengage the top lug.

3 Disconnect the vacuum supply hose.

4 Undo the retaining screw, slide the unit out of its mounting bracket to disengage the retaining lug, and remove the ECU.

### Refitting

5 Refitting is a reversal of removal.

### 12 Knock sensor - removal and refitting

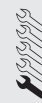

#### Removal

1 The knock sensor (4-cylinder engines only) is located in the centre of the rear-facing side of the cylinder block, beneath the inlet manifold.

2 Jack up the front of the car and support it on stands.

3 Disconnect the wiring multiplug, then unscrew the sensor from its location (see illustrations).

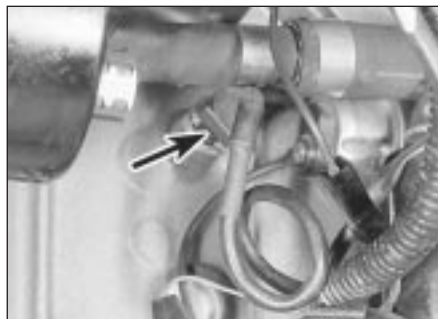

12.3a Disconnect the knock sensor multiplug (arrowed) . . .



12.3b . . . then unscrew the sensor



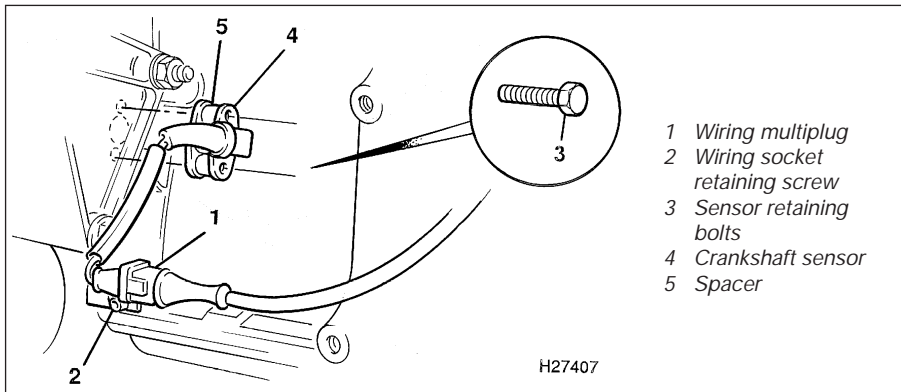

13.3 Crankshaft sensor attachments

**Refitting**

4 Refitting is a reversal of removal, but ensure that the sensor and cylinder block mating faces are clean.

**13 Crankshaft sensor - removal and refitting**



**Removal**

1 The crankshaft sensor, fitted to 4-cylinder engines is attached to the transmission adaptor plate on the rear facing side of the engine.

2 Jack up the front of the car and support it on stands.

3 Disconnect the multiplug from the crankshaft sensor wiring socket (see illustration).

4 Undo the retaining screw and remove the wiring socket from its mounting bracket.

5 Undo the two bolts securing the crankshaft sensor to the adaptor plate, and withdraw the sensor, complete with spacer and wiring socket.

**Refitting**

6 Refitting is a reversal of removal, but ensure that the sensor and cylinder block mating faces are clean.

**14 Crank/cylinder sensor - removal and refitting**



**Removal**

1 The crank/cylinder sensor is located behind the timing belt sprocket on the front facing cylinder head of V6 engines.

2 Remove the timing belt and the front camshaft sprocket as described in Chapter 2, Part B.

3 Undo the four bolts and remove the timing belt backplate from the front cylinder head (see illustration).

4 Disconnect the crank/cylinder sensor wiring

multiplug and undo the cable clip retaining bolt. Slip the sensor wiring harness grommet out of the slot in the cylinder head (see illustration).

5 Undo the two bolts and withdraw the sensor from its location.

**Refitting**

6 Refitting is a reversal of removal. Refer to Chapter 2, Part B for timing belt refitting and adjustment procedures.

**15 Charging system - general information and precautions**

**General information**

The charging system includes the alternator, an internal voltage regulator, a no-charge (or "ignition") warning light, the battery, and the wiring between all the components. The charging system supplies electrical power for the ignition system, the lights, and all the cars accessories. The alternator is driven by the alternator (auxiliary) drivebelt from the crankshaft pulley.

The purpose of the voltage regulator is to limit the alternator's voltage to a preset value. This prevents power surges, circuit overloads, etc., during peak voltage output.

The charging system doesn't ordinarily require periodic maintenance. However, the



14.3 Remove the timing belt backplate from the front cylinder head

drivebelt, battery and the wires and connections should be inspected at the intervals outlined in Chapter 1.

The instrument panel warning light should come on when the ignition key is turned to positions "II" or "III", then should go off immediately the engine starts. If it remains on, or if it comes on while the engine is running, there is a malfunction in the charging system (see Section 16). If the light does not come on when the ignition key is turned, and the bulb is sound (see Chapter 12), there is a fault in the alternator.

**Precautions**

Be very careful when making electrical circuit connections to a vehicle equipped with an alternator, and note the following:

- (a) When reconnecting wires to the alternator from the battery, be sure to note the polarity.
- (b) Before using arc-welding equipment to repair any part of the vehicle, disconnect the wires from the alternator and the battery terminals.
- (c) Never start the engine with a battery charger connected.
- (d) Always disconnect both battery leads before using a battery charger.
- (e) The alternator is driven by an drivebelt which could cause serious injury if your hand, hair or clothes become entangled in it with the engine running.
- (f) Because the alternator is connected directly to the battery, it could arc or cause a fire if overloaded or shorted-out.
- (g) Wrap a plastic bag over the alternator, and secure it with rubber bands, before steam-cleaning or pressure-washing the engine.
- (h) Never disconnect the alternator terminals while the engine is running.

**16 Charging system - testing**



1 If a malfunction occurs in the charging circuit, don't automatically assume that the alternator is causing the problem. First check the following items:

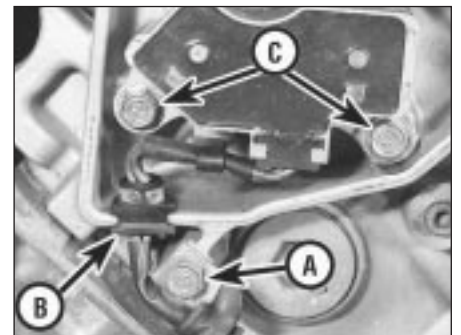

14.4 Crank/cylinder sensor attachments

- A Cable clip retaining bolt
- B Wiring harness grommet
- C Sensor retaining bolts

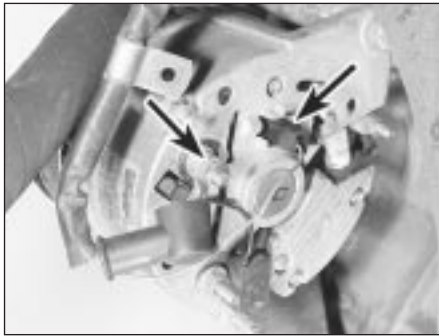

17.4 Typical alternator wiring connections (arrowed) on 4-cylinder engines

- (a) Check the tension and condition of the alternator (auxiliary) drivebelt - renew it if it is worn or deteriorated (see Chapter 1).
- (b) Ensure the alternator mounting bolts and nuts are tight.
- (c) Inspect the alternator wiring harness and the electrical connections at the alternator; they must be in good condition, and tight.
- (d) Check the relevant fuses in the fusebox (see Chapter 12). If any are blown, determine the cause, repair the circuit and renew the fuse (the vehicle won't start and/or the accessories won't work if the fuse is blown).
- (e) Start the engine and check the alternator for abnormal noises - for example, a shrieking or squealing sound may indicate a badly worn bearing or brush.
- (f) Make sure that the battery is fully-charged - one bad cell in a battery can cause overcharging by the alternator.

2 Using a voltmeter, check the battery voltage with the engine off. It should be in excess of 12 volts.

3 Start the engine and check the battery voltage again. Increase engine speed until the voltmeter reading remains steady; it should now be approximately 13.5 to 14.5 volts.

4 Switch on as many electrical accessories (eg the headlights, heated rear window and heater blower) as possible, and check that the alternator maintains the regulated voltage at around 13 to 14 volts. The voltage may drop and then come back up; it may also be



17.12 Pull back the rubber cap and unscrew the main terminal nut



17.10a V6 engine alternator side pivot bolt (arrowed) . . .

necessary to increase engine speed slightly, even if the charging system is working properly.

5 If the voltage reading is greater than the stated charging voltage, renew the voltage regulator (see Section 18).

6 If the voltmeter reading is less than that stated, the fault may be due to worn brushes, weak brush springs, a faulty voltage regulator, a faulty diode, a severed phase winding, or worn or damaged slip rings. The brushes and slip rings may be checked (see Section 18), but if the fault persists, the alternator should be renewed or taken to an auto-electrician for testing and repair.

## 17 Alternator - removal and refitting



### 4-cylinder engines

#### Removal

1 Disconnect the battery negative (earth) lead (refer to Section 1 before doing this).

2 Remove the auxiliary drivebelt as described in Chapter 1.

3 Undo the two nuts and remove the alternator rear cover.

4 Disconnect the electrical leads at the rear of the alternator noting their locations for reconnection (see illustration).

5 On cars with a rear-mounted power steering pump, remove the previously-slackened pivot bolt and adjustment arm bolt,



18.2 Undo the regulator and brushbox retaining screws

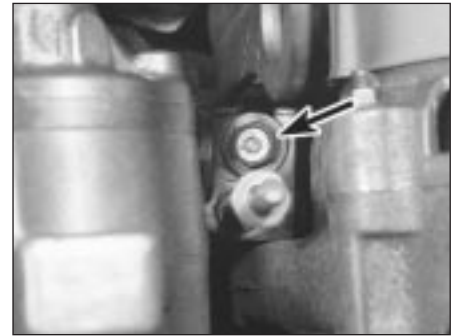

17.10b . . . and adjusting bolt (arrowed)

then withdraw the alternator from the engine.

6 On cars with a front-mounted power steering pump, undo the alternator upper and lower mounting bolts, and remove the unit.

#### Refitting

7 Refitting is a reversal of removal. Refit and adjust the drivebelt (Chapter 1), before tightening the adjustment and mounting bolts.

### V6 engines

#### Removal

8 Disconnect the battery negative (earth) lead (refer to Section 1 before doing this).

9 Undo the three bolts and one nut securing the power steering pump and alternator pulley covers to the top of the engine. Move the pipes and cables clear and lift off the covers.

10 Slacken the alternator side pivot bolt and lower mounting nut, then turn the adjusting bolt anti-clockwise to release the tension on the drivebelt (see illustrations).

11 Slip the drivebelt off the alternator pulley.

12 Pull back the rubber cap and unscrew the main terminal nut, then remove the washers and lead from the terminal stud (see illustration).

13 Disconnect the wiring multiplug from the rear of the alternator and release the wiring harness from the support bracket.

14 Remove the alternator mounting bolts/nuts and the adjusting bolt then remove the unit.

#### Refitting

15 Refitting is a reversal of removal. Adjust the drivebelt as described in Chapter 1, before tightening the mounting bolts/nuts.

## 18 Alternator brushes and voltage regulator - inspection and renewal



1 Remove the alternator as described in Section 17 then proceed as described below the relevant sub-heading.

### A127 alternator - 4-cylinder engines

2 Undo the three small screws securing the regulator and brushbox assembly to the rear of the alternator (see illustration).



18.3a Withdraw the regulator and brushbox . . .

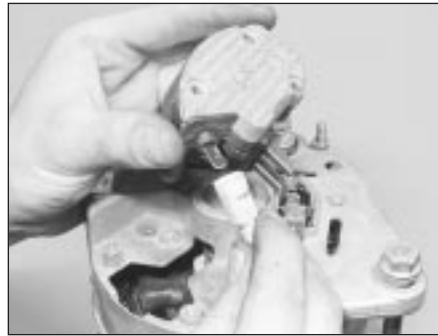

18.3b . . . and disconnect the wiring

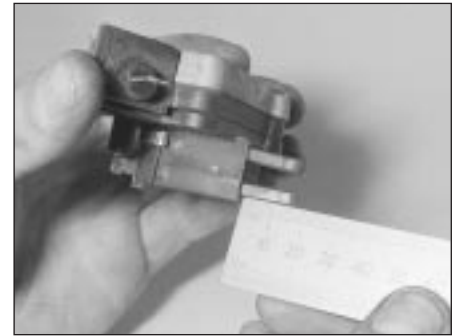

18.4 Checking alternator brush length

- 3 Tip the assembly upwards at the edge, and withdraw it from its location. Disconnect the wiring terminal and remove the regulator and brushbox from the alternator (see illustrations).
- 4 Measure the brush length and renew the brushbox and regulator assembly if the brushes are worn below the figure given in the Specifications (see illustration).
- 5 Clean the slip rings with a solvent-moistened cloth, then check for signs of scoring, burning or severe pitting. If evident, the slip rings should be attended to by an automobile electrician.
- 6 Refitting is a reversal of removal.

**A133 alternator - 4-cylinder engines**

- 7 Disconnect the lead then undo the bolt and remove the suppression capacitor from the alternator rear cover.
- 8 Undo the two retaining screws and remove the rear cover from the alternator.
- 9 Disconnect the regulator leads, undo the retaining screws and remove the regulator from the brush box.
- 10 Undo the retaining screws and extract the brushes from the brush box.
- 11 Undo the retaining screws and withdraw the brush box from the slip ring end bracket.
- 12 Measure the brush length and renew the brushes if worn below the figure given in the Specifications.
- 13 Clean the slip rings with a solvent-moistened cloth, then check for signs of scoring, burning or severe pitting. If evident, the slip rings should be attended to by an automobile electrician.
- 14 Refitting is a reversal of removal.

**A1271 alternator - 4-cylinder engines**

- 15 The A1271 alternator fitted to later models is only serviced as a complete assembly. No parts are available separately and repairs to the unit are not possible.

**CGK 46 alternator - V6 engines**

- 16 Undo the nut, remove the washer and slip off the insulator from the alternator main feed terminal. Note the position of the insulator slot for refitting.

- 17 Undo the three end cover retaining nuts and remove the cover.
- 18 Undo the two brush holder retaining screws and withdraw the brush holder complete with brushes.
- 19 Undo the four regulator retaining screws and withdraw the regulator from the rectifier assembly. Note the screw lengths and their locations for refitting.
- 20 Withdraw the brushes from the brush holder and measure their lengths. Renew the brushes if worn below the figure given in the Specifications.
- 21 Clean the slip rings with a solvent-moistened cloth, then check for signs of scoring, burning or severe pitting. If evident, the slip rings should be attended to by an automobile electrician.
- 22 Refitting is a reversal of removal.

**19 Starting system - general information and precautions**

**General information**

The starting system consists of the battery, the starter motor, the starter solenoid, and the wires connecting them. The solenoid is mounted directly on the starter motor.

When the ignition key is turned to position "III", the starter solenoid is actuated through the starter control circuit. The solenoid then connects the battery to the starter. The battery supplies the electrical energy to the starter motor, which does the actual work of cranking the engine.

The starter motor on a vehicle equipped with automatic transmission can be operated only when the selector lever is in Park or Neutral ("P" or "N").

**Precautions**

Always observe the following precautions when working on the starting system:

- (a) *Excessive cranking of the starter motor can overheat it, and cause serious damage. Never operate the starter motor for more than 15 seconds at a time without pausing to allow it to cool for at*

*least two minutes. Excessive starter operation will also risk unburned fuel collecting in the catalytic converter's element, causing it to overheat when the engine does start (see Chapter 4, Part E).*

(b) *Always detach the lead from the negative terminal of the battery before working on the starting system (see Section 1).*

**20 Starting system - testing**



- 1 If the starter motor does not turn at all when the switch is operated, make sure that, on automatic transmission models, the selector lever is in Park or Neutral ("P" or "N").
- 2 Make sure that the battery is fully-charged, and that all leads, both at the battery and starter solenoid terminals, are clean and secure.
- 3 Check the condition of the relevant fuse and fusible link, referring to Chapter 12 and the wiring diagrams at the end of this manual for further information.
- 4 If the starter motor spins but the engine is not cranking, the overrunning clutch or (when applicable) the reduction gears in the starter motor may be slipping, in which case the starter motor must be overhauled or renewed. (Other possibilities are that the starter motor mounting bolts are very loose, or that teeth are missing from the flywheel ring gear.)
- 5 If, when the switch is actuated, the starter motor does not operate at all but the solenoid clicks, then the problem lies with either the battery, the main solenoid contacts, or the starter motor itself (or the engine is seized).
- 6 If the solenoid plunger cannot be heard to click when the switch is actuated, the battery is faulty, there is a fault in the circuit, or the solenoid itself is defective.
- 7 The solenoid contacts can be checked by connecting a voltmeter or test light between the battery positive feed connection on the starter side of the solenoid, and earth. When the ignition switch is turned to the "start" position, there should be a reading or lighted bulb, as applicable. If there is no reading or lighted bulb, the solenoid is faulty and should be renewed.





21.4 Removing the starter motor on 4-cylinder engines

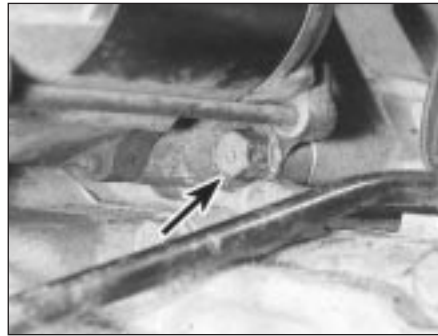

21.11a V6 engine starter motor lower retaining bolt (arrowed)



21.11b Removing the starter motor on V6 engines

8 If the starter motor still does not operate, remove it (see Section 21). The brushes and commutator may be checked (Section 22), but if the fault persists, the motor should be renewed, or taken to an auto-electrician for testing and repair.

9 If the starter motor cranks the engine at an abnormally-slow speed, first make sure that the battery is charged, and that all terminal connections are tight. If the engine is partially seized, or has the wrong viscosity oil in it, it will crank slowly.

10 If the engine is known to be OK, and with the correct viscosity oil, but the cranking speed is still slow, the solenoid contacts are burned, the motor is faulty, or there is a poor internal connection.

2 Refer to the relevant Part of Chapter 4 and remove the air cleaner air intake trunking as necessary to gain access to the starter motor.

3 Disconnect the main feed cable and the Lucar spade connector at the solenoid.

4 Support the weight of the engine/transmission with a jack, then unscrew and remove the starter motor retaining bolts. Withdraw the starter motor from the transmission (see illustration).

**Refitting**

5 Refitting is a reversal of removal, but tighten the retaining bolts to the specified torque.

**V6 engines**

**Removal**

6 Disconnect the battery negative (earth) lead (refer to Section 1 before doing this).

7 Undo the nut and remove the washer and main feed cable from the solenoid terminal stud.

8 Disconnect the smaller Lucar connector from the other solenoid terminal.

9 Apply the handbrake, prise off the left-hand front wheel trim and slacken the wheel nuts. Jack up the front of the car and support it on axle stands. Remove the front roadwheel.

10 Undo the three retaining bolts and remove the access panel from under the front wing.

11 Unscrew and remove the two starter motor retaining bolts and withdraw the starter motor from the transmission (see illustrations).

**Refitting**

12 Refitting is a reversal of removal.

**22 Starter motor - brush renewal**



**M78R starter motor - 4-cylinder engines**

1 Remove the starter motor from the car as described in Section 21.

2 Undo the nut and detach the feed wire from the solenoid terminal stud.

3 Undo the two nuts and two screws then withdraw the commutator end bracket from the yoke (see illustration).

4 Release the rubber grommet from the side of the yoke and withdraw the brush holder assembly complete with brushes (see illustration).

5 Remove the brush springs from the brush holder.

6 Unclip the earth brushes from the brush holder.

7 Remove the insulator plate and withdraw the remaining brushes complete with their connector lead.

8 Clean and inspect the brush assemblies. If the brushes have worn beyond (or down to) the specified minimum length they must be renewed as a set.

**21 Starter motor - removal and refitting**



**4-cylinder engines**

**Note:** On some models, the starter motor is positioned under the inlet manifold, and access is severely limited. No further information was available at the time of writing.

**Removal**

1 Disconnect the battery negative terminal. (Refer to Section 1 before doing this).



22.3 Withdraw the commutator end bracket



22.4 Release the rubber grommet (arrowed) and remove the brush holder



22.10 Using pointed-nose pliers to compress the brushes



**9** Prior to refitting the brushes, check the condition of the commutator face on which they run. Wipe the commutator with a solvent-moistened cloth. If the commutator is dirty, it may be cleaned with fine glass paper, then wiped with the cloth.

**10** Fit the new brushes using a reversal of the removal procedure. When refitting the brush holder assembly, carefully compress the brushes one at a time using pointed-nose pliers, tip the holder slightly and ease the brushes over the commutator (see illustration).

### ***M79 starter motor - 4-cylinder engines***

**11** Undo the two retaining screws and remove the end cap and seal.

**12** Wipe free the grease from the end of the armature shaft then prise free and remove the C-clip from the shaft groove. Remove the spacer(s).

**13** Unscrew the retaining nut and detach the connecting link from the solenoid.

**14** Undo the two retaining screws and withdraw the solenoid yoke from the drive end housing. Lift it upwards and disengage the solenoid armature from the actuation lever in the end housing.

**15** Unscrew and remove the two through-bolts then remove the commutator end housing from the yoke and armature unit.

**16** Detach the brush housing insulator and withdraw the brushes from the housing.

**17** If the brushes have worn down to or beyond the minimum length specified, they must be renewed as a set. To renew them, cut their leads mid-point and make a secure soldered joint when connecting the new brushes.

**18** Prior to refitting the brushes, check the condition of the commutator face on which they run. Wipe the commutator with a solvent-moistened cloth. If the commutator is dirty, it may be cleaned with fine glass paper, then wiped with the cloth.

**19** Fit the new brushes and reassemble the starter motor unit using a reversal of the removal procedure. Make sure that the brushes move freely in their holders. When fitting the armature unit to the yoke, engage the actuating arm in the drive end housing together with the plastic bracket (locates in the notch in the yoke face) and rubber block. Ensure that the drive end housing is correctly aligned before fully tightening the retaining screws.

### ***DR 5U1 starter motor - V6 engines***





**20** Brushes are not separately available for this starter motor and, should renewal be necessary, a complete brush holder and yoke assembly must be obtained. As this is likely to be prohibitively expensive, a better alternative may be to obtain a complete reconditioned starter motor, or seek the advice of an automobile electrician.

# Chapter 9 Braking system

## Contents

Anti-lock braking system - component removal and refitting . . . . .	25	Hydraulic pipes and hoses - inspection, removal and refitting . . . . .	15
Anti-lock braking system - general information . . . . .	24	Hydraulic system - bleeding . . . . .	2
Brake check . . . . .	See Chapter 1	Master cylinder - removal and refitting . . . . .	11
Brake fluid level check . . . . .	See Chapter 1	Master cylinder (ABS models) - overhaul . . . . .	13
Brake fluid renewal . . . . .	See Chapter 1	Master cylinder (non-ABS models) - overhaul . . . . .	12
Brake pedal - removal and refitting . . . . .	16	Pressure-reducing valve - general information, removal and refitting . . . . .	14
Front brake disc - inspection, removal and refitting . . . . .	6	Rear brake caliper - overhaul . . . . .	9
Front brake caliper - overhaul . . . . .	5	Rear brake caliper - removal and refitting . . . . .	8
Front brake caliper - removal and refitting . . . . .	4	Rear brake disc - inspection, removal and refitting . . . . .	10
Front brake pads - renewal . . . . .	3	Rear brake pads - renewal . . . . .	7
General information . . . . .	1	Stop-light switch - removal, refitting and adjustment . . . . .	21
Handbrake - adjustment . . . . .	17	Underbonnet check for fluid leaks and hose condition . . . . .	See Chapter 1
Handbrake cable (front) - removal and refitting . . . . .	19	Vacuum servo unit - general information and testing . . . . .	22
Handbrake cable (rear) - removal and refitting . . . . .	20	Vacuum servo unit - removal and refitting . . . . .	23
Handbrake lever - removal and refitting . . . . .	18		

## Degrees of difficulty

<b>Easy</b> , suitable for novice with little experience 	<b>Fairly easy</b> , suitable for beginner with some experience 	<b>Fairly difficult</b> , suitable for competent DIY mechanic 	<b>Difficult</b> , suitable for experienced DIY mechanic 	<b>Very difficult</b> , suitable for expert DIY or professional 
---	--	--	---	--

## Specifications

### General

System type . . . . .	Diagonally-split, dual-circuit hydraulic with pressure-reducing valve in rear hydraulic circuit and cable operated handbrake. Anti-lock braking system (ABS) available as standard or optional equipment on later models.
-----------------------	---

### Front brakes

Type . . . . .	Ventilated disc with single-piston sliding calipers
Disc diameter:	
4-cylinder engine models without turbo . . . . .	262.0 mm
4-cylinder turbo engine models and V6 engine models . . . . .	285.0 mm
Disc thickness:	
New . . . . .	21.0 mm
Minimum . . . . .	19.0 mm
Maximum thickness variation . . . . .	0.015 mm
Maximum disc run-out . . . . .	0.040 mm
Brake pad thickness (including backing but excluding shims):	
New . . . . .	17.4 mm
Minimum . . . . .	8.2 mm
ABS wheel speed sensor-to-reluctor ring clearance . . . . .	0.30 to 1.02 mm

### Rear brakes

Type . . . . .	Solid disc with single-sliding calipers
Disc diameter . . . . .	260.0 mm
Disc thickness:	
New . . . . .	10.0 mm
Minimum . . . . .	8.0 mm
Maximum thickness variation . . . . .	0.015 mm
Maximum disc run-out . . . . .	0.040 mm
Brake pad thickness (including backing):	
New . . . . .	14.5 mm
Minimum . . . . .	7.2 mm
ABS wheel speed sensor-to-reluctor ring clearance . . . . .	0.055 to 1.11 mm

## 9•2 Braking system

### Handbrake

Handbrake linkage lever-to-stop pin clearance . . . . . 0.5 to 2.0 mm

### Torque wrench settings

	Nm	lbf ft
Caliper guide pin bolts . . . . .	33	24
Front caliper carrier bracket to steering knuckle . . . . .	75	55
Rear caliper carrier bracket to hub carrier . . . . .	45	33
Caliper bleed screws . . . . .	10	7
Brake hose banjo union bolts . . . . .	35	26
Brake pipe union nuts:		
M10 . . . . .	15	11
M12 . . . . .	22	16
Brake disc retaining screws . . . . .	12	9
Handbrake linkage cover to rear caliper . . . . .	10	7
Handbrake lever to floor . . . . .	25	18
Handbrake front cable guide plate bolts . . . . .	25	18
Handbrake rear cable support clip bolts . . . . .	10	7
Master cylinder to servo unit nuts . . . . .	25	18
Servo unit to bulkhead nuts . . . . .	25	18
Brake pedal pivot bolt . . . . .	25	18
Pressure reducing valve mounting bracket bolts . . . . .	10	7
Hydraulic modulator mounting nuts (ABS) . . . . .	10	7
Wheel speed sensor to sensor bracket bolt (ABS) . . . . .	10	7
Wheel speed sensor bracket bolts (ABS) . . . . .	25	18
Wheel speed sensor wiring clips and bracket bolts (ABS) . . . . .	10	7
Copy valve mounting bracket bolts (ABS) . . . . .	10	7
Roadwheel nuts . . . . .	110	81

### 1 General information

The braking system is of the servo-assisted, dual-circuit hydraulic type, incorporating disc brakes at the front and rear. A diagonally-split dual circuit hydraulic system is employed, in which each circuit operates one front and one diagonally opposite rear brake from a tandem master cylinder. Under normal conditions, both circuits operate in unison; however, in the event of hydraulic failure in one circuit, full braking force will still be available at two wheels. A pressure-reducing valve is incorporated in the rear brake hydraulic circuit. This valve regulates the hydraulic pressure applied to each rear brake, and reduces the possibility of the rear wheels locking under heavy braking.

Self-adjusting single-piston sliding type calipers are used in conjunction with ventilated and solid discs at the front and rear respectively. A cable-operated handbrake provides an independent mechanical means of rear brake application.

An anti-lock braking system (ABS) is available on some models and features many of the components in common with the conventional braking system. Further details on the ABS can be found later in this Chapter. **Note:** When servicing any part of the system, work carefully and methodically; also observe scrupulous cleanliness when overhauling any part of the hydraulic system. Always renew

components (in axle sets, where applicable) if in any doubt about their condition, and use only genuine Rover or Unipart replacement parts, or at least those of known good quality. Note the warnings given in "Safety First" at the beginning of this manual and at relevant points in this Chapter concerning the dangers of asbestos dust and hydraulic fluid.

### 2 Hydraulic system - bleeding



**Warning:** Hydraulic fluid is poisonous; wash off immediately and thoroughly in the case of skin contact, and seek immediate medical advice if any fluid is swallowed or gets into the eyes. Certain types of hydraulic fluid are inflammable, and may ignite when allowed into contact with hot components; when servicing any hydraulic system, it is safest to assume that the fluid IS inflammable, and to take precautions against the risk of fire as though it is petrol that is being handled. Finally, it is hygroscopic (it absorbs moisture from the air). The more moisture is absorbed by the fluid, the lower its boiling point becomes, leading to a dangerous loss of braking under hard use. Old fluid may be contaminated and unfit for further use. When topping-up or renewing the fluid, always use the recommended type, and ensure that it comes from a freshly-opened sealed container.



**Haynes Hint** Hydraulic fluid is an effective paint stripper, and will attack plastics; if any is spilt, it should be washed off immediately, using copious quantities of clean water.

### General

**1** The correct functioning of the brake hydraulic system is only possible after removing all air from the components and circuit; this is achieved by bleeding the system.

**2** During the bleeding procedure, add only clean, fresh hydraulic fluid of the specified type; never re-use fluid that has already been bled from the system. Ensure that sufficient fluid is available before starting work.

**3** If there is any possibility of incorrect fluid being used in the system, the brake lines and components must be completely flushed with uncontaminated fluid and new seals fitted to the components.

**4** If brake fluid has been lost from the master cylinder due to a leak in the system, ensure that the cause is traced and rectified before proceeding further.

**5** Park the vehicle on level ground, switch off the ignition and select first gear (manual transmission) or Park (automatic transmission) then chock the wheels and release the handbrake.

**6** Check that all pipes and hoses are secure, unions tight, and bleed screws closed. Remove the dust caps and clean any dirt from around the bleed screws.

7 Unscrew the master cylinder reservoir cap, and top up the reservoir to the "MAX" level line. Do not invert the cap or hydraulic fluid may short out the cap contacts causing the warning light on the instrument panel to flash. Refit the cap loosely, and remember to maintain the fluid level at least above the "MIN" level line throughout the procedure, otherwise there is a risk of further air entering the system.

8 There are a number of one-man, do-it-yourself, brake bleeding kits currently available from motor accessory shops. It is recommended that one of these kits is used wherever possible, as they greatly simplify the bleeding operation, and also reduce the risk of expelled air and fluid being drawn back into the system. If such a kit is not available, the basic (two-man) method must be used, which is described in detail below.

9 If a kit is to be used, prepare the vehicle as described previously, and follow the kit manufacturer's instructions, as the procedure may vary slightly according to the type being used; generally, they are as outlined below in the relevant sub-section.

10 Whichever method is used, the correct sequence must be followed (paragraphs 11 to 15) to ensure the removal of all air from the system.

### Bleeding sequence

11 If the hydraulic system has only been partially disconnected and suitable precautions were taken to minimise fluid loss, it should only be necessary to bleed that part of the system (ie the primary or secondary circuit).

12 If the complete system is to be bled, then it should be done in the following sequence:

#### Non-ABS models

- (a) Left-hand front wheel.
- (b) Right-hand rear wheel.
- (c) Right-hand front wheel.
- (d) Left-hand rear wheel.

#### ABS-models

13 Two types of ABS system may be fitted to models covered by this manual. Although generally similar in operation, the bleeding sequence is different for each, and it is necessary to identify the system being worked on before proceeding.

14 The easiest way to distinguish between the two types is to locate the hydraulic modulator unit in the engine compartment and note the arrangement of the hydraulic pipe connections. On the early type modulator there are six pipe connections; four on the upper face and two on the front face. On the later modulator there are also six pipe connections but all are on the front face of the unit.

15 Having identified the unit fitted, the bleeding sequence is as follows:

#### Early type modulator

- (a) Left-hand front wheel.
- (b) Right-hand rear wheel.
- (c) Right-hand front wheel.
- (d) Left-hand rear wheel.

#### Later type modulator

- (a) Left-hand front wheel.
- (b) Right-hand front wheel.
- (c) Left-hand rear wheel.
- (d) Right-hand rear wheel.

### Bleeding - basic (two-man) method

16 Collect a clean glass jar and a length of plastic or rubber tubing, which is a tight fit over the bleed screw, and a ring spanner to fit the screws. The help of an assistant will also be required.

17 If not already done, remove the dust cap from the bleed screw of the first wheel to be bled and fit a spanner and tube to the screw.

18 Immerse the other end of the bleed tube in the jar, which should contain enough fluid to cover the end of the tube.

19 Ensure that the master cylinder reservoir fluid level is maintained at least above the "MIN" level line throughout the procedure.

20 Open the bleed screw about half a turn, and have your assistant depress the brake pedal with a smooth steady stroke down to the floor, and then hold it there. When the flow of fluid through the tube stops, tighten the bleed screw and have your assistant release the pedal slowly.

21 Repeat this operation (paragraph 20) until clean brake fluid, free from air bubbles, can be seen flowing from the end of the tube.

22 When no more air bubbles appear, tighten the bleed screw, remove the bleed tube and refit the dust cap. Repeat these procedures on the remaining bleed screws in sequence until all air is removed from the system and the brake pedal feels firm again.

### Bleeding - using a one-way valve kit

23 As their name implies, these kits consist of a length of tubing with a one-way valve fitted, to prevent expelled air and fluid being drawn back into the system; some kits incorporate a translucent container, which can be positioned so that the air bubbles can be more easily seen flowing from the end of the tube.

24 The kit is connected to the bleed screw, which is then opened. The user returns to the driver's seat, depresses the brake pedal with a smooth steady stroke, and slowly releases it; this is repeated until the expelled fluid is clear of air bubbles.

25 Note that these kits simplify work so much that it is easy to forget the master cylinder fluid level; ensure that this is maintained at least above the "MIN" level line at all times.

### Bleeding - using a pressure-bleeding kit

26 These kits are usually operated by the reserve of pressurised air contained in the spare tyre. However, note that it will be necessary to reduce the pressure to a lower level than normal; refer to the instructions supplied with the kit.

27 By connecting a pressurised, fluid-filled container to the master cylinder reservoir, bleeding is carried out by opening each bleed screw in turn (in the specified sequence) and allowing fluid to run out, rather like turning on a tap, until no air bubbles can be seen in the expelled fluid.

28 This method has the advantage that the large reservoir of fluid provides an additional safeguard against air being drawn into the system during bleeding.

29 Pressure bleeding is particularly effective when bleeding "difficult" systems, or when bleeding the complete system at the time of routine fluid renewal.

### All methods

30 When bleeding is completed, check and top up the fluid level in the master cylinder reservoir.

31 Check the feel of the brake pedal. If it feels at all spongy, air must still be present in the system, and further bleeding is indicated. Failure to bleed satisfactorily after a reasonable repetition of the bleeding operations may be due to worn master cylinder seals.

32 Discard brake fluid which has been bled from the system; it will not be fit for re-use.

## 3 Front brake pads - renewal



**Warning:** Disc brake pads must be renewed on both front wheels at the same time - never renew the pads on only one wheel as uneven braking may result. Dust created by wear of the pads may contain asbestos, which is a health hazard. Never blow it out with compressed air and do not inhale any of it. DO NOT use petroleum-based solvents to clean brake parts. Use brake cleaner or methylated spirit only. DO NOT allow any brake fluid, oil or grease to contact the brake pads or disc. Also refer to the warning at the start of Section 2 concerning the dangers of hydraulic fluid.

**Note:** New caliper lower guide pin bolts will be required for refitting.

1 Apply the handbrake, remove the front wheel trim and slacken the wheel nuts. Jack up the front of the car and support it on axle stands. Remove the front roadwheels.

2 Where fitted, disconnect the pad wear warning light wiring plug (left-hand caliper only) and using a spanner, unscrew the lower



## 9•4 Braking system

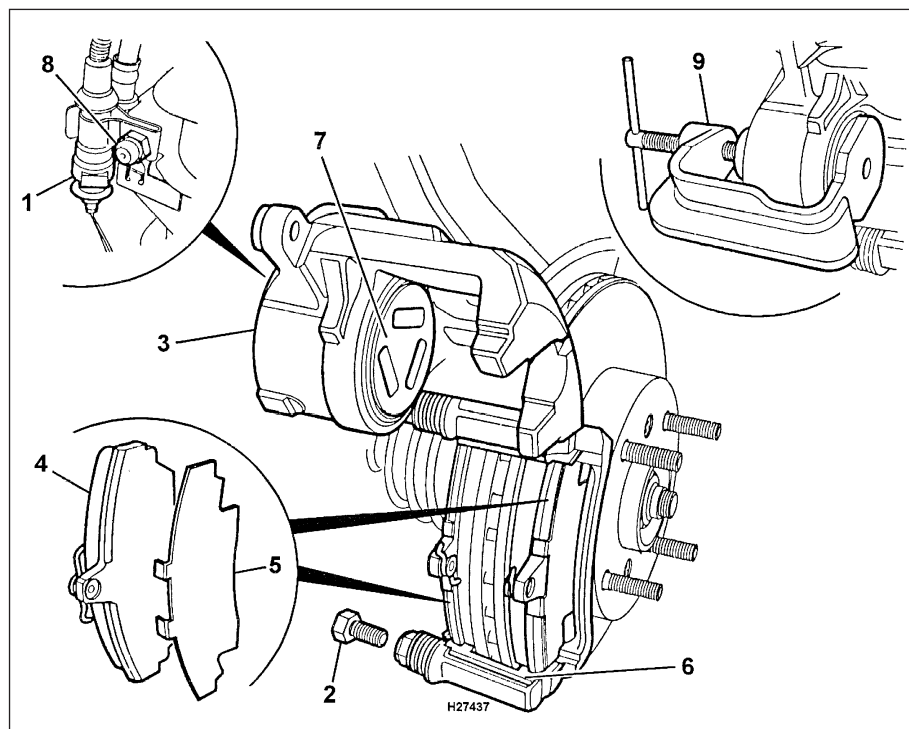

**3.2a Front brake pad renewal**

- |   |                                   |   |
|---|-----------------------------------|---|
| 1 Pad wear warning light wiring plug (where fitted) | 4 Brake pads                      | 7 Piston heat shield                            |
| 2 Lower guide pin bolt                              | 5 Pad shims                       | 8 Bleed screw                                   |
| 3 Caliper body                                      | 6 Anti-rattle shim (where fitted) | 9 Using a G-clamp to retract the caliper piston |



**3.2b Unscrew the caliper lower guide pin bolt**

guide pin bolt while holding the guide pin with a second spanner (see illustrations).

**3** Pivot the caliper body upwards and tie it up, using a length of string, under the wheelarch (see illustration).

**4** Lift out the two brake pads together with their shims then, where fitted, remove the upper and lower anti-rattle shims from the caliper carrier bracket (see illustrations). If the pads are to be re-used, identify them so that they can be refitted in their original positions.

**5** Remove the heat shield from the caliper piston (see illustration).

**6** Brush the dust and dirt from the caliper, piston, disc, and pads, but **do not** inhale it, as it is injurious to health.

**7** Rotate the disc by hand, and scrape away any rust and scale. Carefully inspect the entire surface of the disc, and if there are any signs of cracks, deep scoring or severe abrasions, the disc must be renewed.

**8** Inspect the caliper for fluid leaks around the piston, signs of corrosion, or other damage. Check the guide pin rubber boots for condition, and the pins themselves for free movement in the carrier bracket. Renew any suspect parts as necessary, with reference to Section 5.

**9** If new pads are to be fitted, it will be necessary to push the caliper piston back into its bore to accommodate the new, thicker pads. To do this first remove the dust cap, then fit a tube over the end of the bleed



**3.3 Pivot the caliper body upwards**



**3.4a Lift out the brake pads together with their shims**



**3.4b Remove the upper anti-rattle shim ...**



**3.4c ... and lower anti-rattle shim**



**3.5 Remove the heat shield from the caliper piston**

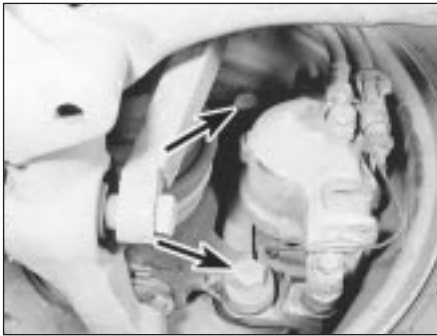

4.7 Carrier bracket-to-steering knuckle retaining bolts (arrowed)

screw. Submerge the free end of the tube in a jar containing a small quantity of brake fluid.

10 Open the bleed screw approximately half a turn, then push the piston back into its bore, as far as it will go, using a G-clamp, or pieces of wood, as levers. When the piston has fully retracted, close the bleed screw, remove the tube and refit the dust cap.

11 To refit the pads, first place the anti-rattle shims (where fitted) in position in the carrier bracket and fit the heat shield to the piston.

12 Place the shims against the backs of the pads, then fit the pads to the carrier bracket. If working on the left-hand caliper, the pad with the warning light lead must be fitted nearest to the centre of the car.

13 Swing the caliper down over the pads and secure it with a new guide pin bolt. Tighten the bolt to the specified torque.

14 Reconnect the warning light wiring plug (where applicable).

15 Repeat the above procedure on the opposite front brake caliper.

16 Refit the roadwheels and lower the car to the ground.

17 Tighten the roadwheel nuts to the specified torque and refit the wheel trims.

18 Depress the brake pedal several times to bring the pistons into contact with the pads then check, and if necessary top up, the fluid in the master cylinder reservoir.

#### 4 Front brake caliper - removal and refitting



**Note:** Before starting work, refer to the warning at the beginning of Section 2 concerning the dangers of hydraulic fluid, and to the warning at the beginning of Section 3 concerning the dangers of asbestos dust.

**Note:** New caliper guide pin bolts and brake hose copper washers will be required for refitting.

##### Removal

1 Apply the handbrake, remove the front wheel trim and slacken the wheel nuts. Jack up the front of the car and support it on axle stands. Remove the front roadwheel.

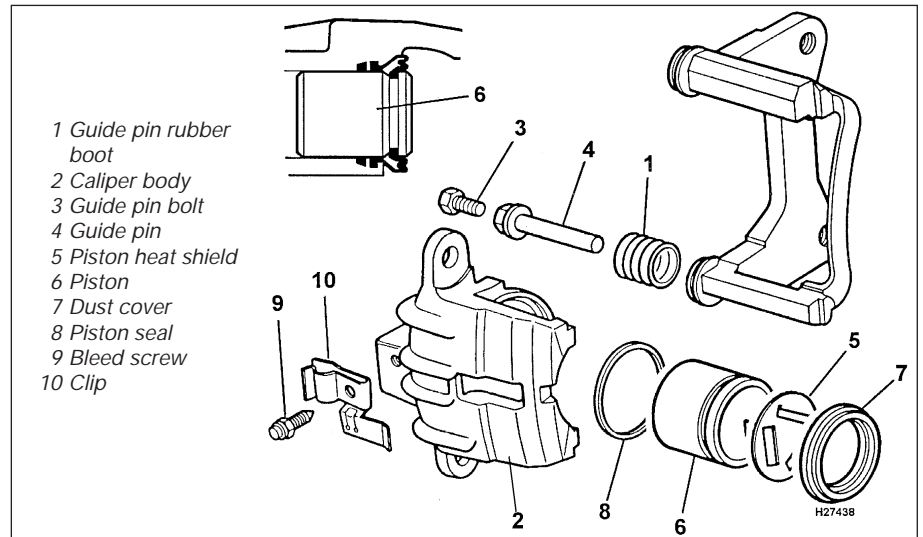

5.3 Front brake caliper components

2 If working on the left-hand caliper, disconnect the pad wear warning light wiring plug (where fitted) and release the wiring harness from the support clip.

3 Using a brake hose clamp, or self-locking wrench with protected jaws, clamp the flexible brake hose. This will minimise fluid loss during subsequent operations.

4 Wipe clean the area around the brake hose connection at the caliper then unscrew the brake hose banjo union bolt at the caliper body, and recover the two copper washers. Tape over the hose union and caliper orifice to prevent dirt ingress.

5 Using a spanner, unscrew the lower guide pin bolt while holding the guide pin with a second spanner.

6 Unscrew the upper guide pin bolt in the same way, then lift away the caliper, leaving the brake pads and carrier bracket in place.

7 If the carrier bracket is to be removed, undo the two bolts securing it to the steering knuckle, and remove the bracket complete with brake pads (see illustration). The pads can be removed, if required, with reference to Section 3.

##### Refitting

8 Refitting is a reversal of removal. Ensure that new guide pin bolts are fitted and tighten all fastenings to the specified torque. Use new copper washers on the brake hose banjo union, and bleed the hydraulic system as described in Section 2.

#### 5 Front brake caliper - overhaul



1 Remove the caliper from the car as described in the previous Section.

2 With the caliper on the bench wipe away all traces of dust and dirt, but **do not** inhale it, as it is injurious to health.

3 Remove the heat shield from the caliper piston (see illustration).

4 Using low air pressure, such as from a tyre foot pump, eject the piston by holding the pump hose against the caliper fluid inlet port.

5 Remove the dust cover from the piston.

6 Using a blunt instrument such as a knitting needle, carefully extract the piston seal from the caliper bore.

7 Clean all the parts in methylated spirit, or clean brake fluid, and dry with a lint-free cloth. Inspect the piston and caliper bore for signs of damage, scuffing or corrosion, and if these conditions are evident, renew the caliper assembly complete. Renew the guide pins in the carrier bracket if they are bent or damaged, or if their rubber boots are split or perished.

8 If the components are in a satisfactory condition, a repair kit consisting of new seals and dust cover should be obtained.

9 Thoroughly lubricate the caliper bore, piston, piston seal and dust cover with clean brake fluid, and carefully fit the seal to the caliper bore.

10 Position the dust cover over the innermost end of the piston, so that the caliper bore sealing lip protrudes beyond the base of the piston. Using a blunt instrument, if necessary, engage the sealing lip of the dust cover with the groove in the caliper. Now push the piston into the caliper bore until the other sealing lip of the dust cover can be engaged with the groove in the piston. Having done this, push the piston fully into its bore. Ease the piston out again slightly, and make sure that the dust cover lip is correctly seating in the piston groove.

11 Remove the guide pins from the carrier bracket, if not already done, and smear them with high-melting-point brake grease. Fit new rubber boots to the guide pins if necessary, and refit them to the carrier bracket.

12 The caliper can now be refitted as described in the previous Section.

## 9•6 Braking system

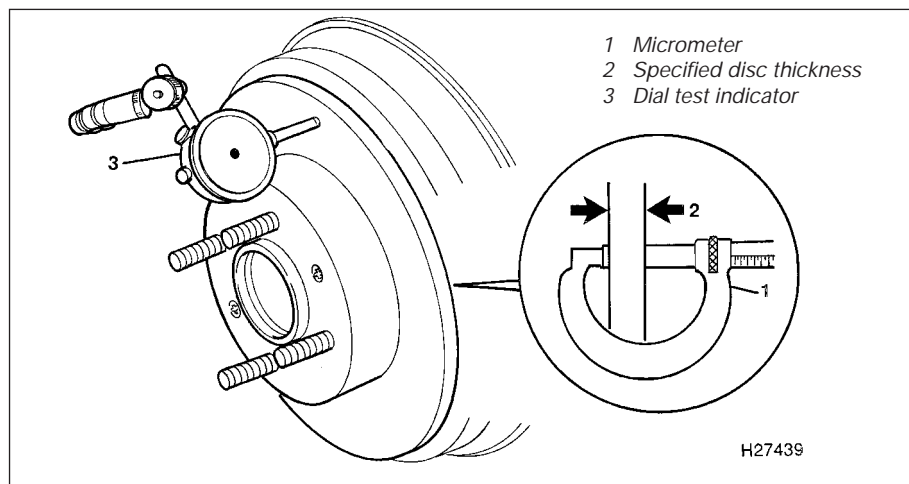

6.5 Checking front brake disc thickness and run-out

### 6 Front brake disc - inspection, removal and refitting



**Note:** Before starting work, refer to the warning at the beginning of Section 3 concerning the dangers of asbestos dust.

#### Inspection

1 Apply the handbrake, remove the front wheel trim and slacken the wheel nuts. Jack up the front of the car and support it on axle stands. Remove the front roadwheel.

2 Undo the two bolts securing the brake caliper carrier bracket to the steering knuckle.  
3 Withdraw the carrier bracket, complete with caliper and brake pads, from the disc and steering knuckle. Tie the caliper assembly from a convenient place under the wheelarch to avoid straining the brake hose.

4 Rotate the disc and examine it for deep scoring or grooving on both sides. Light scoring is normal, but if excessive the disc must be renewed.

5 Using a micrometer, measure the disc thickness at four places around the disc at about 10.0 mm in from the outer edge (see illustration). Compare the thickness with the figures given in the Specifications.

6 If a dial test indicator is available, check the

disc run-out by mounting the indicator with its probe positioned about 6.0 mm in from the outer edge of the disc. Rotate the disc slowly, noting the reading on the indicator. Compare this with the figures given in the Specifications.

7 If the disc thickness, or thickness variation, is outside the figures given in the Specifications, the disc must be renewed. If the disc run-out is excessive, remove the disc, turn it through 180°, refit it and check the run-out once more. If still excessive, renewal of the disc is necessary.

#### Removal

8 Remove the brake caliper and carrier bracket as described in paragraphs 1 to 3.

9 Undo the two retaining screws and withdraw the disc from the hub flange (see illustrations). If it is tight, tap it lightly from behind using a hide or plastic mallet.

#### Refitting

10 Refitting is a reversal of removal. Ensure that the mating face of the disc and hub flange are thoroughly clean, and tighten all retaining bolts to the specified torque.

### 7 Rear brake pads - renewal



**Warning:** Disc brake pads must be renewed on both rear wheels at the same time - never renew the pads on only one wheel as uneven braking may result. Dust created by wear of the pads may contain asbestos, which is a health hazard. Never blow it out

uneven braking may result. Dust created by wear of the pads may contain asbestos, which is a health hazard. Never blow it out



6.9a Undo the two retaining screws (arrowed) . . .



6.9b . . . and withdraw the disc from the hub flange

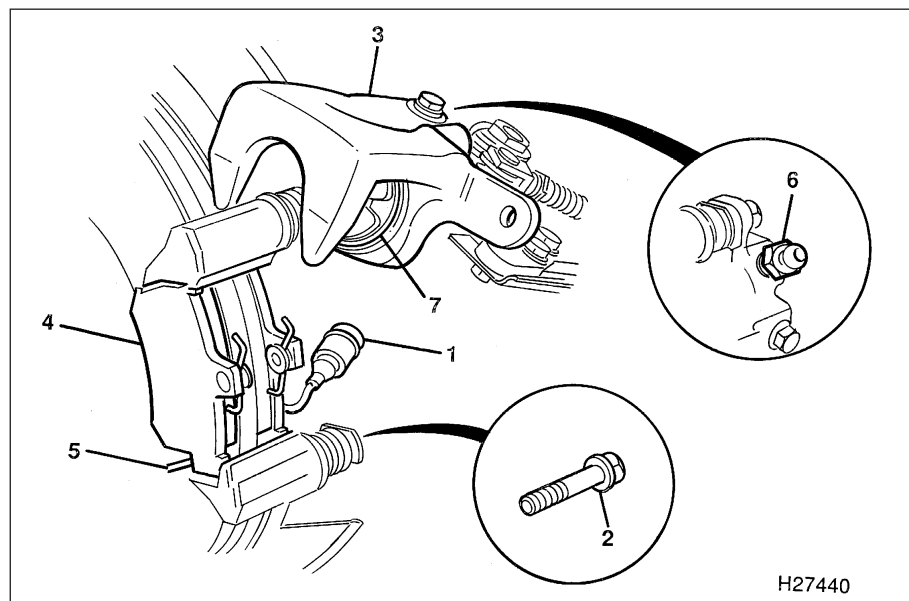

7.2a Rear brake pad renewal

- |   |                                   |
|---|-----------------------------------|
| 1 Pad wear warning light wiring plug (where fitted) | 4 Brake pad                       |
| 2 Guide pin bolt                                    | 5 Anti-rattle shim (where fitted) |
| 3 Caliper body                                      | 6 Bleed screw                     |
|   | 7 Piston                          |



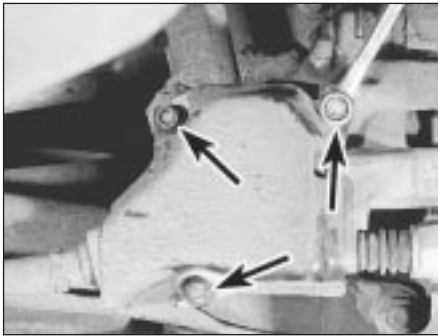

7.2b Undo the three handbrake linkage cover retaining bolts (arrowed)

with compressed air and do not inhale any of it. **DO NOT use petroleum-based solvents to clean brake parts. Use brake cleaner or methylated spirit only. DO NOT allow any brake fluid, oil or grease to contact the brake pads or disc. Also refer to the warning at the start of Section 2 concerning the dangers of hydraulic fluid.** **Note:** New caliper guide pin bolts will be required for refitting.

1 Chock the front wheels, remove the wheel trim and slacken the rear wheel nuts. Jack up the rear of the car and support it on axle stands. Remove the rear roadwheels and ensure that the handbrake is released.

2 On early models, undo the three handbrake linkage cover securing bolts and remove the cover from the caliper (see illustrations).

3 Where fitted, disconnect the pad wear warning light wiring plug (left-hand caliper).

4 Using a spanner, unscrew the upper and lower guide pin bolts (see illustration).

5 Withdraw the caliper and handbrake linkage assembly from the brake pads and carrier bracket.

6 Lift out the two brake pads, then, where fitted, remove the upper and lower anti-rattle shims from the caliper carrier bracket (see illustrations). If the pads are to be re-used, identify them so that they can be refitted in their original positions.

7 Brush the dust and dirt from the caliper, piston, disc, and pads, but **do not** inhale it, as it is injurious to health.



7.6b ... followed by the upper anti-rattle shim ...

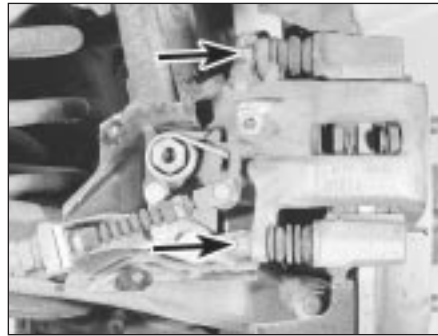

7.4 Rear caliper upper and lower guide pin bolt locations (arrowed)

8 Rotate the disc by hand, and scrape away any rust and scale. Carefully inspect the entire surface of the disc, and if there are any signs of cracks, deep scoring or severe abrasions, the disc must be renewed.

9 Inspect the caliper for fluid leaks around the piston, signs of corrosion, or other damage. Check the guide pin rubber boots for condition, and the pins themselves for free movement in the carrier bracket. Renew any suspect parts as necessary, with reference to Section 9.

10 If new pads are to be fitted, it will be necessary to screw the caliper piston into its bore to accommodate the new, thicker pads. Remove the dust cap and fit a tube over the end of the bleed screw. Submerge the free end of the tube in a jar containing a small quantity of brake fluid.

11 Open the bleed screw approximately half a turn, then screw the piston back fully into its bore by turning it clockwise with a pair of angled circlip pliers or other similar tool (see illustration). If necessary, turn the piston up to 1/4 turn anti-clockwise so that one of the cutouts will align with the projection on the inboard pad. Now close the bleed screw, remove the tube and refit the protective cap.

12 To refit the pads, first place the anti-rattle shims (where fitted) in position in the carrier bracket.

13 Fit the pads to the carrier bracket, noting that the pad with the warning light lead (left-



7.6c ... and lower anti-rattle shim



7.6a Lift out the two brake pads ...

hand caliper only) must be fitted nearest to the centre of the car.

14 Place the caliper over the pads, and secure with new guide pin bolts, tightened to the specified torque.

15 Refit the warning light wiring plug (where applicable) and the handbrake linkage cover.

16 Depress the brake pedal several times to automatically adjust the brake pads and the handbrake linkage. *Do not apply the handbrake until the rear pads have self-adjusted otherwise incorrect brake operation will result.*

17 Repeat the above procedure on the opposite rear brake unit.

18 Check, and if necessary top up, the fluid in the master cylinder reservoir then refit the roadwheels and lower the car to the ground. Tighten the roadwheel nuts to the specified torque and refit the wheel trim.

## 8 Rear brake caliper - removal and refitting



**Note:** Before starting work, refer to the warning at the beginning of Section 2 concerning the dangers of hydraulic fluid, and to the warning at the beginning of Section 7 concerning the dangers of asbestos dust.

**Note:** New caliper guide pin bolts and brake hose copper washers will be required for refitting.



7.11 Using angled circlip pliers to screw the piston back into the caliper. Note the position of the cut-outs



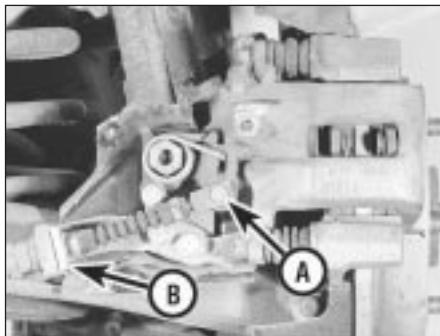

8.5 Handbrake cable clevis pin (A) and cable retaining clip (B)

### Removal

- 1 Chock the front wheels, remove the wheel trim and slacken the rear wheel nuts. Jack up the rear of the car and support it on axle stands. Remove the rear roadwheel and ensure that the handbrake is released.
- 2 Undo the three bolts securing the handbrake linkage cover, and remove the cover from the side of the caliper.
- 3 On the left-hand caliper, disconnect the pad wear warning light wiring plug (where fitted) and release the wiring from the support clip.
- 4 Undo the two bolts and remove the front half of the handbrake linkage cover.
- 5 Extract the retaining clip and withdraw the clevis pin from the end of the handbrake cable (see illustration).
- 6 Prise off the handbrake cable retaining clip and withdraw the cable from the mounting bracket.
- 7 To minimise fluid loss, clamp the flexible hose using a brake hose clamp, or self-locking wrench with protected jaws.
- 8 Wipe clean the area around the brake hose connection at the caliper then unscrew the brake hose banjo union bolt at the caliper body, and recover the two copper washers. Tape over the hose union and caliper orifice to prevent dirt ingress.
- 9 Using a spanner, unscrew the upper and lower guide pin bolts.
- 10 Withdraw the caliper and handbrake linkage assembly from the brake pads and carrier bracket, and remove it from the car.
- 11 If the carrier bracket is to be removed, undo the two bolts securing it to the hub carrier, and remove the bracket complete with brake pads. The pads can be removed, if required, with reference to Section 7.

### Refitting

- 12 Refitting is a reversal of removal, but tighten all bolts to the specified torque. Use new copper washers on the brake hose banjo union, and bleed the hydraulic system as described in Section 2. *Do not apply the handbrake until the rear brakes have been bled otherwise incorrect brake operation will result.*

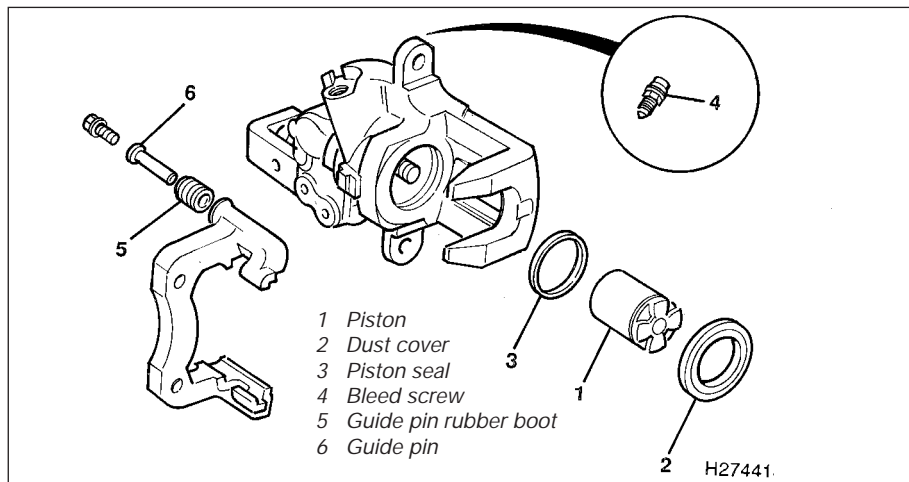

9.5 Rear brake caliper components

### 9 Rear brake caliper - overhaul

- 1 Remove the caliper from the car as described in the previous Section.
- 2 With the caliper on the bench wipe away all traces of dust and dirt, but **do not** inhale it, as it is injurious to health.
- 3 Undo the two bolts and remove the handbrake linkage bracket assembly from the caliper.
- 4 Using a pair of angled circlip pliers or other similar tool, turn the piston anti-clockwise to unscrew it from the caliper.
- 5 Remove the dust cover from the piston (see illustration).
- 6 Using a blunt instrument such as a knitting needle, carefully extract the piston seal from the caliper bore.
- 7 Clean all the parts in methylated spirit, or clean brake fluid, and dry with a lint-free cloth. Inspect the piston and caliper bore for signs of damage, scuffing or corrosion, and if these conditions are evident, renew the caliper assembly complete. Renew the guide pins in the carrier bracket if they are bent or damaged, or if their rubber boots are split or perished.
- 8 If the components are in a satisfactory condition, a repair kit consisting of new seals and dust cover should be obtained.
- 9 Thoroughly lubricate the caliper bore, piston, piston seal and dust cover with clean brake fluid, and carefully fit the seal to the caliper bore.
- 10 Position the dust cover over the innermost end of the piston, so that the caliper bore sealing lip protrudes beyond the base of the piston. Using a blunt instrument, if necessary, engage the sealing lip of the dust cover with the groove in the caliper. Screw the piston into the caliper bore until the other sealing lip of the dust cover can be engaged with the groove in the piston. With the piston screwed in all the way, make sure that the dust cover is

correctly located in the piston and caliper grooves.

- 11 Remove the guide pins from the carrier bracket, if not already done, and smear them with high-melting-point brake grease. Fit new rubber boots to the guide pins and refit them to the carrier bracket. Ensure that the guide pin with the rubber insert is fitted in the rearmost position.
- 12 Attach the handbrake linkage bracket assembly to the caliper and secure with the two bolts.
- 13 The caliper can now be refitted to the car as described in the previous Section.

### 10 Rear brake disc - inspection, removal and refitting

**Note:** Before starting work, refer to the warning at the beginning of Section 7 concerning the dangers of asbestos dust.

#### Inspection

- 1 Chock the front wheels, remove the wheel trim and slacken the rear wheel nuts. Jack up the rear of the car and support it on axle stands. Remove the rear roadwheel and ensure that the handbrake is released.
- 2 Undo the two bolts securing the brake caliper carrier bracket to the rear hub carrier (see illustration).



10.2 Carrier bracket-to-rear hub carrier retaining bolts (arrowed)



**10.3** Release the rear flexible brake hose support clip from the suspension strut



**10.4** Tie up the caliper assembly to avoid straining the brake hose



**10.7a** Undo the two retaining screws . . .

**3** Undo the retaining bolt and release the flexible brake hose support clip from the suspension strut (**see illustration**).

**4** Withdraw the carrier bracket, complete with caliper and brake pads, from the disc and hub carrier. Tie the caliper assembly from a convenient place under the wheelarch to avoid straining the brake hose (**see illustration**).

**5** The inspection procedures are the same as for the front brake disc, and reference should be made to Section 6, paragraphs 4 to 7 inclusive.

### Removal

**6** Remove the brake caliper and carrier bracket as described in paragraphs 1 to 4.

**7** Undo the two retaining screws and withdraw the disc from the hub flange (**see illustrations**). If it is tight, tap it lightly from behind using a hide or plastic mallet.

### Refitting

**8** Refitting is a reversal of removal. Ensure that the mating face of the disc and hub flange are thoroughly clean, and tighten all retaining bolts to the specified torque.

## 11 Master cylinder - removal and refitting



**Note:** Before starting work, refer to the warning at the beginning of Section 2 concerning the dangers of hydraulic fluid.

### Removal

**1** Disconnect the wiring multiplug from the fluid level warning indicator in the reservoir filler cap, then remove the filler cap from the reservoir. Note that the filler cap must not be inverted. The reservoir should now be emptied by syphoning or drawing out the fluid with a pipette.

**2** Place rags beneath the master cylinder to absorb any remaining brake fluid when the pipe unions are undone. If any brake fluid is spilled on the car paintwork, wash it off immediately with copious amounts of cold water.

**3** On manual transmission models, detach the clutch fluid supply hose from the side of the reservoir.

**4** Unscrew the two brake pipe union nuts, and carefully withdraw the pipes from the master cylinder (**see illustration**). Tape over the pipe ends to prevent dirt ingress.

**5** Undo the two nuts, remove the washers, and withdraw the master cylinder from the servo unit. Recover the O-ring seal between master cylinder and servo.

### Refitting

**6** Refitting is a reversal of removal. Renew the master cylinder-to-servo O-ring seal, and tighten all retaining nuts to the specified torque. Bleed the brakes as described in Section 2. On manual transmission models, bleed the clutch hydraulic system as described in Chapter 6.

## 12 Master cylinder (non-ABS models) - overhaul



**Note:** Two different types of master cylinder have been fitted to non-ABS equipped Rover models covered by this manual (**see illustrations**). The following procedures are mainly applicable to the early unit fitted until approximately October 1991. The later unit is similar, but at the time of writing no specific



**10.7b** . . . and withdraw the rear disc from the hub flange

overhaul information was available from the manufacturer.

**1** Remove the master cylinder from the car as described in the previous Section. Drain any fluid remaining in the reservoir, and prepare a clean, uncluttered working surface ready for dismantling.

**2** Hold the cylinder body firmly, and push the reservoir sideways to release it from its seals. Lift the reservoir off, and remove the two seals from the fluid inlet ports.

**3** Push the primary piston down the cylinder bore slightly, and hold it there. Locate the stop-pin in the secondary inlet port, and withdraw the pin using pointed-nose pliers.

**4** With the piston held down, extract the circlip, using circlip pliers, from the cylinder bore end, and remove the washer behind the circlip.

**5** Using a small blunt screwdriver, hook out the O-ring seal from the groove in the cylinder bore.

**6** Remove the primary piston.

**7** Lubricate the cylinder bore with clean hydraulic fluid to aid removal of the secondary piston.

**8** Tap the cylinder body on a block of wood to release the secondary piston, then withdraw the piston from the cylinder bore.

**9** Remove the secondary piston spring, seal retainer, rear seal, washer and front seal.

**10** Remove the seal housing, seal and washer from the primary piston. Do not dismantle the primary piston further, as seals



**11.4** Unscrew the two brake pipe unions (arrowed) at the master cylinder

## 9•10 Braking system

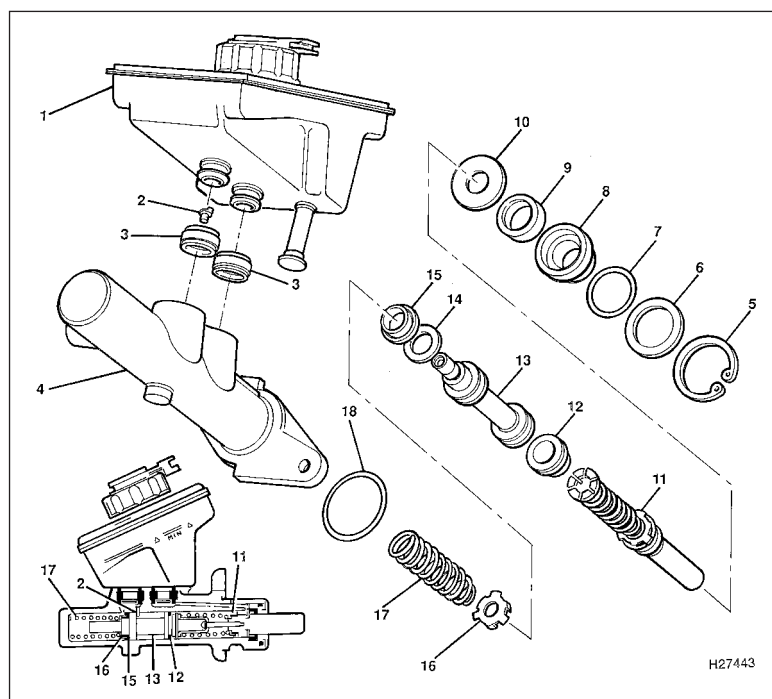

**12.0a Exploded view of the early type master cylinder - non-ABS models**

- |                               |                                   |
|-------------------------------|-----------------------------------|
| 1 Reservoir                   | 10 Primary piston washer          |
| 2 Stop-pin                    | 11 Primary piston assembly        |
| 3 Reservoir seals             | 12 Secondary piston front seal    |
| 4 Cylinder body               | 13 Secondary piston               |
| 5 Piston retaining circlip    | 14 Secondary piston washer        |
| 6 Washer                      | 15 Secondary piston rear seal     |
| 7 O-ring seal                 | 16 Secondary piston seal retainer |
| 8 Primary piston seal housing | 17 Secondary piston spring        |
| 9 Primary piston seal         | 18 O-ring                         |

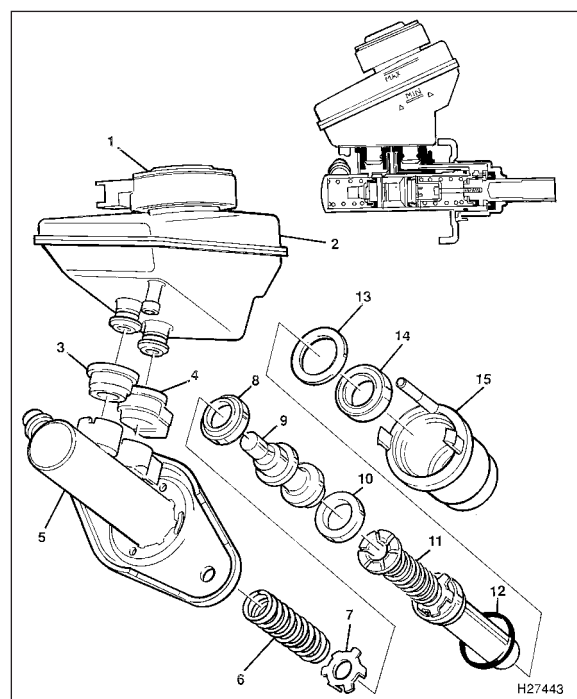

**12.0b Exploded view of the later type master cylinder - non-ABS models**

- |                                    |                                |
|------------------------------------|--------------------------------|
| 1 Reservoir filler cap             | 8 Secondary piston rear seal   |
| 2 Reservoir                        | 9 Secondary piston seal        |
| 3 Reservoir secondary circuit seal | 10 Secondary piston front seal |
| 4 Reservoir primary circuit seal   | 11 Primary piston assembly     |
| 5 Cylinder body                    | 12 O-ring seal                 |
| 6 Secondary piston spring          | 13 Vacuum seal packing ring    |
| 7 Secondary piston seal            | 14 Vacuum seal                 |
|                                    | 15 Transfer housing            |

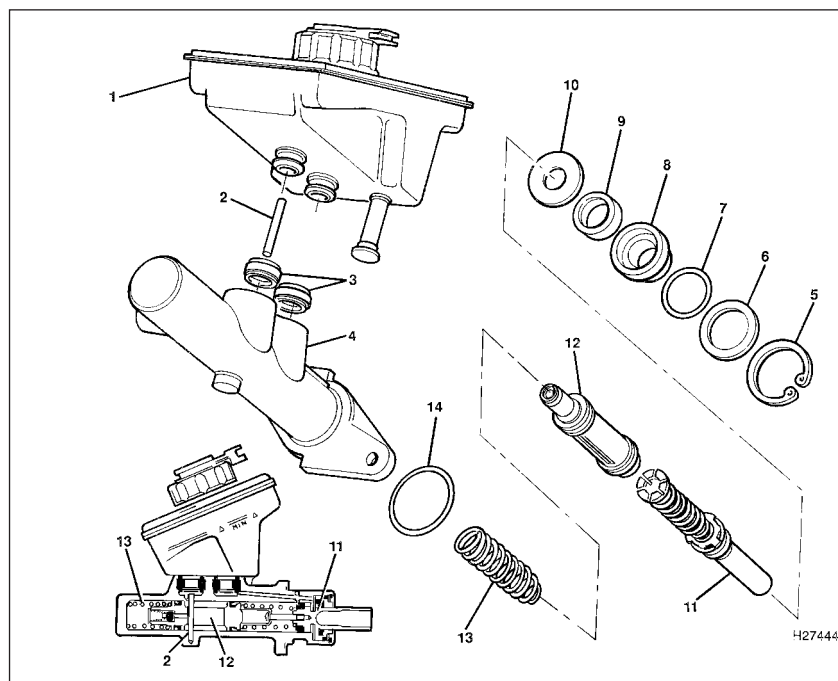

**13.0a Exploded view of the early type master cylinder - ABS models**

- |                               |
|-------------------------------|
| 1 Reservoir                   |
| 2 Stop-pin                    |
| 3 Reservoir seals             |
| 4 Cylinder body               |
| 5 Piston retaining circlip    |
| 6 Washer                      |
| 7 O-ring seal                 |
| 8 Primary piston seal housing |
| 9 Primary piston seal         |
| 10 Primary piston washer      |
| 11 Primary piston assembly    |
| 12 Secondary piston assembly  |
| 13 Secondary piston spring    |
| 14 O-ring                     |

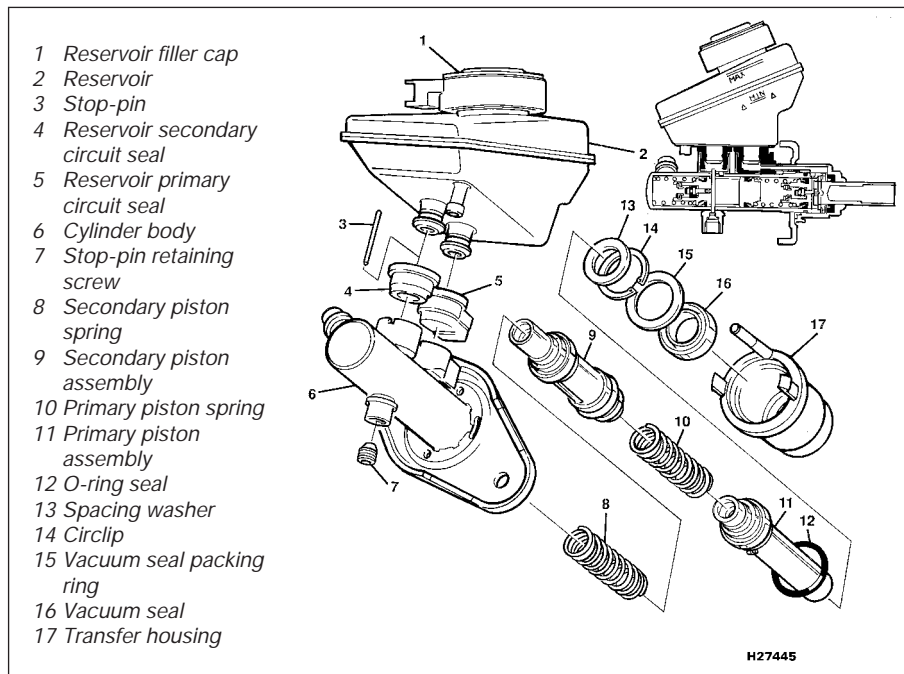

13.0b Exploded view of the later type master cylinder - ABS models

are not available separately. If the master cylinder is in a serviceable condition, and is to be re-used, a new primary piston assembly is included in the repair kit.

11 With the master cylinder dismantled, clean all the components in methylated spirit, or clean hydraulic fluid, and dry with a lint-free cloth.

12 Carefully examine the cylinder bore and secondary piston for signs of wear, scoring or corrosion, and if evident, renew the complete master cylinder assembly.

13 If the components are in a satisfactory condition, obtain a repair kit consisting of new seals, springs and primary piston assembly.

14 Lubricate the cylinder bore, pistons and seals thoroughly in clean hydraulic fluid, and assemble them wet.

15 Using your fingers only, fit the front seal to the secondary piston, followed by the washer, rear seal, seal retainer and spring.

16 Fit the washer, seal housing and seal to the primary piston.

17 Insert the secondary piston into the cylinder bore, using a circular rocking motion to avoid turning over the lips of the seals.

18 Fit the primary piston in the same way.

19 Fit a new O-ring seal to the groove in the cylinder bore, then refit the washer and circlip.

20 Push the primary piston down the bore, and refit the stop-pin to the secondary inlet port.

21 Fit two new seals to the reservoir fluid inlet ports, then push the reservoir firmly into place.

22 Fit a new seal to the reservoir filler cap, then refit the master cylinder to the car as described in Section 11.

### 13 Master cylinder (ABS models) - overhaul



**Note:** Two different types of master cylinder have been fitted to ABS equipped Rover models covered by this manual (see *illustrations*). The following procedures are mainly applicable to the early unit fitted until approximately October 1991. The later unit is similar, but at the time of writing no specific overhaul information was available from the manufacturer.

1 Remove the master cylinder from the car as described in Section 11. Drain any fluid remaining in the reservoir, and prepare a clean, uncluttered working surface ready for dismantling.

2 Hold the cylinder body firmly, and push the reservoir sideways to release it from its seals. Lift the reservoir off, and remove the two seals from the fluid inlet ports.

3 Push the primary piston down the cylinder bore slightly, and hold it there. Locate the stop-pin in the secondary inlet port, and withdraw the pin using pointed-nose pliers.

4 With the piston held down, extract the circlip, using circlip pliers, from the cylinder bore end, and remove the washer behind the circlip.

5 Using a small blunt screwdriver, hook out the O-ring seal from the groove in the cylinder bore.

6 Remove the primary piston.

7 Lubricate the cylinder bore with clean hydraulic fluid to aid removal of the secondary piston.

8 Tap the cylinder body on a block of wood to release the secondary piston, then withdraw the piston from the cylinder bore.

9 Remove the seal housing, seal and washer from the primary piston. Do not dismantle either of the pistons further as seals are not available separately. If the master cylinder is in a serviceable condition, and is to be re-used, a repair kit including new primary and secondary piston assemblies will be required.

10 With the master cylinder dismantled, clean all the components in methylated spirit, or clean hydraulic fluid, and dry with a lint-free cloth.

11 Carefully examine the cylinder bore for signs of wear, scoring or corrosion, and if evident, renew the complete master cylinder assembly.

12 If the components are in a satisfactory condition, obtain a repair kit and two new piston assemblies.

13 Lubricate the cylinder bore, pistons and seals thoroughly in clean hydraulic fluid, and assemble them wet.

14 Fit the washer, seal housing and seal to the primary piston.

15 Insert the secondary piston into the cylinder bore, using a circular rocking motion to avoid turning over the lips of the seals. Align the slot in the piston with the stop-pin hole in the cylinder secondary inlet port.

16 Fit the primary piston in the same way.

17 Fit a new O-ring seal to the groove in the cylinder bore, then refit the washer and circlip.

18 Push the primary piston down the bore, and refit the stop-pin to the secondary inlet port.

19 Fit two new seals to the reservoir fluid inlet ports, then push the reservoir firmly into place.

20 Fit a new seal to the reservoir filler cap, then refit the master cylinder to the car as described in Section 11.

### 14 Pressure-reducing valve - general information, removal and refitting



**Note:** Before starting work, refer to the warning at the beginning of Section 2 concerning the dangers of hydraulic fluid.

#### General information

1 The pressure-reducing valve is mounted on the left-hand side of the engine compartment behind the battery.

2 The purposes of the valve is to distribute brake fluid to the front and rear brakes (rear brakes only on cars fitted with ABS), and to limit the fluid pressure supplied to the rear brakes under heavy braking.

3 The operation of the valve may be suspect if one or both rear wheels continually lock under heavy braking. It is essential, however,



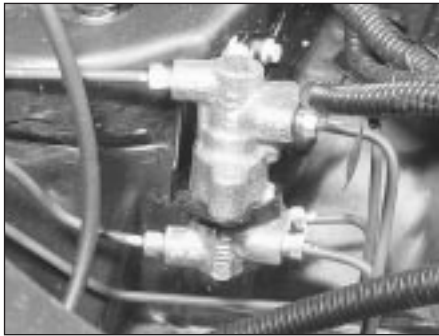

14.6 Pressure-reducing valve mountings and pipe attachments

before condemning the valve to ensure that the brake assemblies themselves, or adverse road conditions, are not causing this condition. In the event of a valve internal failure, brake fluid will be seen seeping from the vent plug on the front of the valve which is covered by a plastic strap. Repair or overhaul of the valve is not possible, and the unit must be renewed as a complete assembly if faulty.

**Removal**

- 4 Remove the master cylinder reservoir filler cap, place a piece of polythene over the filler neck, and seal it tightly with an elastic band. This will minimise hydraulic fluid loss during subsequent operations.
- 5 Place rags beneath the valve to collect any hydraulic fluid that may escape when the pipe unions are undone. If any hydraulic fluid is spilled on the car paintwork, wash it off immediately with copious amounts of cold water.
- 6 Identify the locations of each of the brake pipe unions, unscrew the union nuts and carefully withdraw the pipes clear of the valve (see illustration). Tape over the pipe ends and valve orifices to prevent dirt ingress.
- 7 Undo the two bolts securing the valve mounting bracket to the inner wing, and remove the valve assembly.

**Refitting**

- 8 Refitting is a reversal of removal. Bleed the hydraulic system as described in Section 2 on completion.

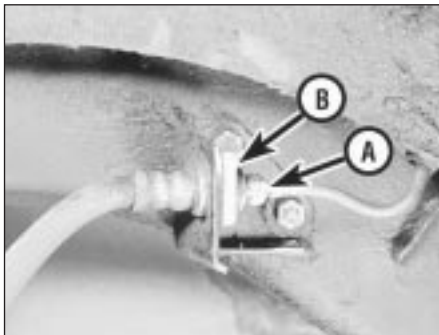

15.8 Flexible brake hose rigid pipe union nut (A) and hose retaining clip (B)

**15 Hydraulic pipes and hoses - inspection, removal and refitting**

**Note:** Before starting work, refer to the warning at the beginning of Section 2 concerning the dangers of hydraulic fluid.

**Inspection**

- 1 Jack up the front, then the rear of the car in turn, and securely support it on axle stands so that the pipes and hoses under the wheelarches and on the suspension assemblies can be inspected.
- 2 First check for signs of leakage at the pipe unions. Examine the flexible hoses for signs of cracking, chafing or deterioration of the rubber.
- 3 The brake pipes must be examined carefully and methodically. They must be cleaned off and checked for signs of dents, corrosion or other damage. Corrosion should be scraped off and, if the depth of pitting is significant, the pipes renewed. The pipes are however protected by a plastic sleeve, and any corrosion that does occur is likely to be near the pipe unions where the sleeve protection ends.
- 4 Renew any defective brake pipes and/or hoses.

**Removal**

- 5 If any section of pipe or hose is to be removed, first unscrew the master cylinder reservoir filler cap and place a piece of polythene over the filler neck. Secure the polythene with an elastic band, ensuring that an airtight seal is obtained. This will minimise hydraulic fluid loss when the pipe or hose is removed.
- 6 As the front-to-rear brake pipes run inside the car, it will be necessary to determine the route of the pipe, then remove any interior trim panels as necessary for access (see Chapter 11). Once this is done, the union nuts at each end can be unscrewed, the pipe and union pulled out, and the pipe removed from the car or underbody clips as applicable. Where the union nuts are exposed, unprotected from the full force of the weather, they can sometimes



15.9 Front brake hose support bracket on the steering knuckle

be quite tight. As only an open-ended spanner can be used, burring of the flats on the nuts is not uncommon when attempting to undo them. For this reason, a self-locking wrench is often the only way to separate a stubborn union.

- 7 To remove a flexible hose, wipe the unions and brackets free of dirt and undo the union nut at the brake pipe end.
- 8 Next extract the hose retaining clip, and lift the end of the hose out of its bracket (see illustration).
- 9 If a front hose is being removed, undo the two bolts securing the hose support bracket to the steering knuckle (see illustration). At the rear, a single bolt secures the support bracket to the shock absorber strut.
- 10 Undo the banjo bolt securing the hose to the brake caliper, recover the two copper washers, one on each side of the union, and remove the hose (see illustration). Use new copper washers when refitting.
- 11 Brake pipes can be obtained individually, or in sets, from Rover dealers or larger accessory shops, cut to length and with the end flares and union nuts in place. The pipe is then bent to shape, using the old pipe as a guide, and is ready for fitting to the car.

**Refitting**

- 12 Refitting the pipes and hoses is a reversal of removal. Make sure that the hoses are not kinked when in position, and will not chafe any suspension or steering component with suspension movement. Ensure also that the brake pipes are securely supported in their clips. After refitting, remove the polythene from the reservoir and bleed the hydraulic system as described in Section 2.

**16 Brake pedal - removal and refitting**

**Removal**

- 1 From inside the car, release the turnbuckles and lift out the trim panel over the clutch, brake and accelerator pedals.



15.10 Front brake hose-to-caliper banjo union bolt (arrowed)

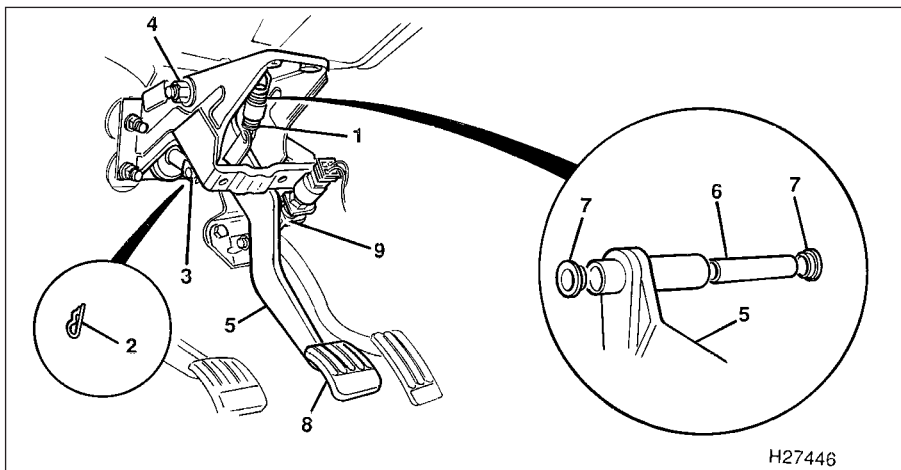

H27446

**16.2 Brake pedal mounting details**

- |                          |                    |                     |
|--------------------------|--------------------|---------------------|
| 1 Return spring          | 4 Pedal pivot bolt | 7 Pedal bushes      |
| 2 Clevis pin spring clip | 5 Brake pedal      | 8 Pedal pad         |
| 3 Clevis pin             | 6 Spacer tube      | 9 Stop-light switch |

- 2 Disconnect the return spring from the brake pedal and pedal bracket (see illustration).
- 3 Extract the retaining spring clip and withdraw the clevis pin securing the brake servo pushrod to the pedal.
- 4 Undo the nut, remove the washer and withdraw the brake pedal pivot bolt from the pedal bracket. Remove the pedal from the car.
- 5 Prise out the two pedal bushes and withdraw the spacer tube.
- 6 Check the condition of the components, and renew as necessary.

**Refitting**

- 7 Refitting is a reversal of removal.

**17 Handbrake - adjustment**



- 1 Due to the self-adjusting action of the rear brakes, adjustment of the handbrake should normally only be necessary after removal and refitting of any of the handbrake components.

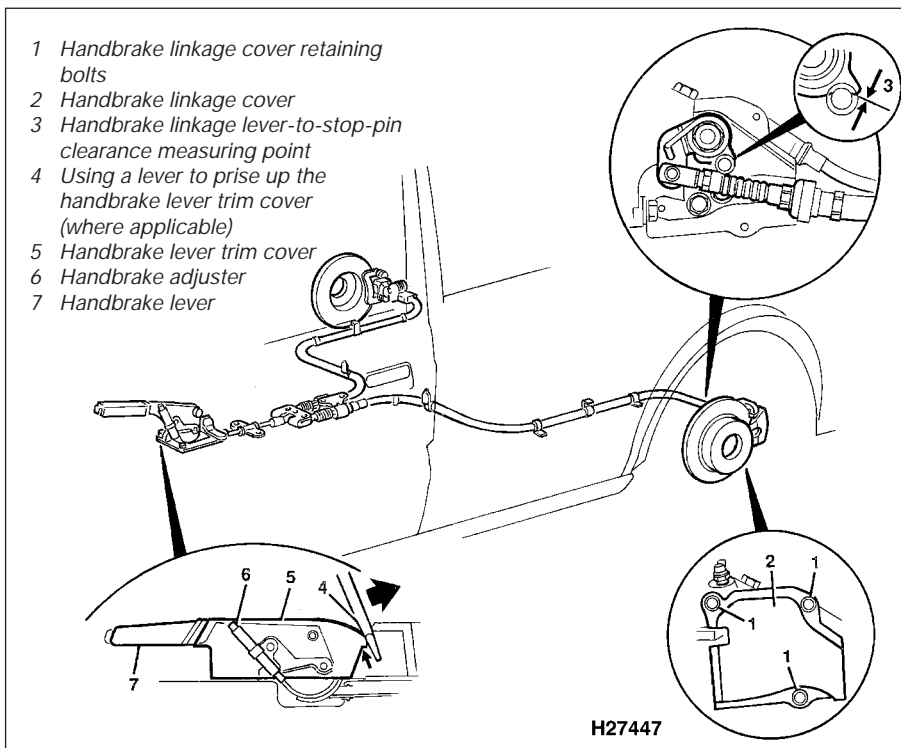

H27447

**17.4 Handbrake adjustment details**

- 2 To check the adjustment, chock the front wheels, remove the rear wheel trim and slacken the roadwheel nuts. Jack up the rear of the car and support it on axle stands. Remove both rear roadwheels and release the handbrake.

- 3 On early models, undo the three bolts each side securing the handbrake linkage covers to the rear brake calipers, and remove the covers.

- 4 Check the clearance between the handbrake linkage lever and the stop-pin on both calipers (see illustration). If the clearance on either side is outside the tolerance given in the Specifications, adjust the handbrake using the following procedure. If the clearance is satisfactory, proceed to paragraph 9.

- 5 On later models it will be necessary to remove the centre console, as described in Chapter 11, for access to the handbrake adjuster. On early models it is only necessary to remove the handbrake lever trim cover as follows. From inside the car, carefully prise out the coin holders or switch panels on each side of the centre console, then raise the lid on the cassette holder at the rear of the console.

- 6 Using a screwdriver as a lever, carefully prise up the rear of the handbrake lever trim cover, and remove the cover from the lever (see illustrations).

- 7 Turn the handbrake adjuster on the side of the handbrake lever to increase or decrease the previously-measured clearance, as



**17.6a** Prise up the rear of the handbrake lever trim cover . . .

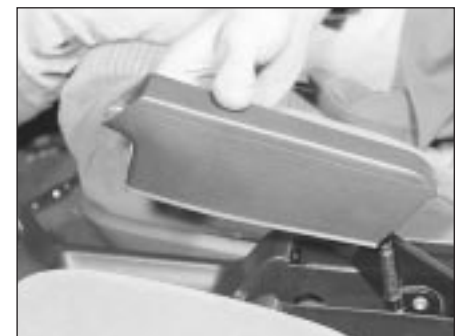

**17.6b** . . . and remove the cover from the lever



17.7 Handbrake adjuster location (arrowed)

necessary (see illustration). Turning the adjuster clockwise will decrease the clearance, and turning it anti-clockwise will increase it.

8 Operate the handbrake two or three times, and recheck the clearance once more. Make a final adjustment if required, then refit the trim cover to the lever, or refit the centre console, as applicable.

9 Refit the linkage covers to the brake calipers, refit the roadwheels and lower the car to the ground. Tighten the wheel nuts and refit the wheel trim.

## 18 Handbrake lever - removal and refitting



### Removal

1 Refer to Chapter 11 and remove the centre console.

2 Chock the front wheels, remove the rear wheel trim and slacken the wheel nuts. Jack up the rear of the car and support it on axle stands. Remove the rear roadwheels and release the handbrake.

3 From inside the car, unscrew the handbrake adjuster on the side of the lever, and remove the adjuster and spacing washer from the front cable (see illustration).

4 Detach the front cable from the handbrake lever.



18.3 Unscrew the handbrake adjuster on the side of the lever

5 Disconnect the wiring plug from the warning light switch on the other side of the lever (see illustration).

6 Undo the four bolts securing the lever assembly to the floor (see illustration).

7 Lift up the lever assembly, release the cable and gaiter, and recover the lever-to-floor gasket. Remove the lever assembly from the car.

8 If required, the warning light switch can be removed after undoing the two screws.

### Refitting

9 Refitting is a reversal of removal. Adjust the handbrake as described in Section 17 before lowering the car to the ground.

## 19 Handbrake cable (front) - removal and refitting



### Removal

1 Refer to Chapter 11 and remove the centre console.

2 Chock the front wheels, remove the rear wheel trim and slacken the wheel nuts. Jack up the rear of the car and support it on axle stands. Remove the rear roadwheels and release the handbrake.

3 Undo the bolts securing the exhaust mounting, and remove the heat shield by twisting it around the exhaust system (see illustration).



18.5 Disconnect the warning light switch wiring plug (arrowed)

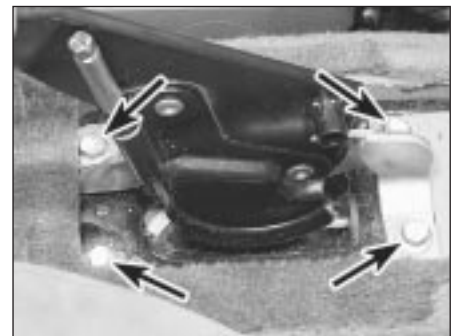

18.6 Undo the four handbrake lever retaining bolts (arrowed)

4 Extract the spring clip and withdraw the clevis pin securing the front handbrake cable to the compensator (see illustration).

5 Undo the two bolts securing the front cable guide plate to the underbody (see illustration).

6 From inside the car, undo the four bolts securing the handbrake lever assembly to the floor.

7 Disconnect the wiring plug from the warning light switch on the side of the handbrake lever, then remove the lever assembly, complete with front cable, from the car. Recover the lever-to-floor gasket.

8 Unscrew the handbrake adjuster on the

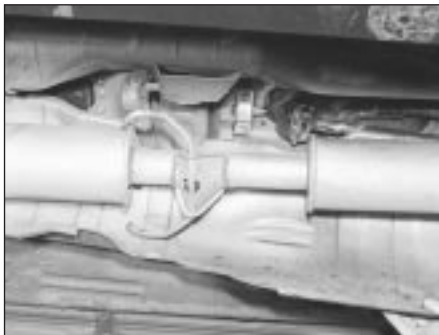

19.3 Removing the front heat shield from the exhaust system



19.4 Extract the cable retaining spring clip and clevis pin (arrowed)

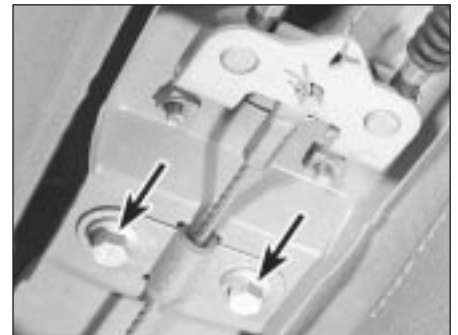

19.5 Undo the front cable guide plate retaining bolts (arrowed)



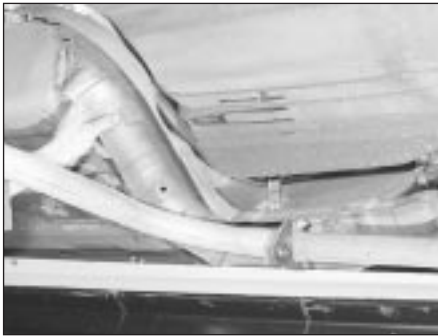

20.3 Removing the rear heat shield from the exhaust system

side of the lever, and remove the adjuster and spacing washer from the front cable.

9 Release the front cable and gaiter from the handbrake lever assembly, then remove the cable from the gaiter.

### Refitting

10 Refitting is a reversal of removal. Adjust the handbrake as described in Section 17 before lowering the car to the ground.

## 20 Handbrake cable (rear) - removal and refitting



### Removal

1 Chock the front wheels, remove the rear wheel trim and slacken the wheel nuts. Jack up the rear of the car and support it on axle stands. Remove the rear roadwheels and release the handbrake.

2 Release the exhaust system rubber mountings, lower the system at the rear, and support it on blocks to avoid straining the front flexible joint.

3 Undo the retaining bolts and remove the front and rear exhaust system heat shields (see illustration).

4 On early models, undo the three bolts and remove the handbrake linkage cover from the brake caliper.

5 Extract the spring clip and withdraw the

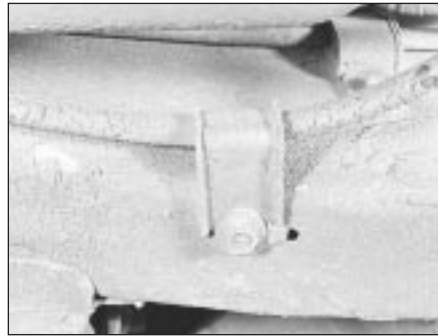

20.7a Cable support on the chassis member . . .

clevis pin securing the handbrake cable to the linkage lever on the caliper (see illustration 8.5).

6 Withdraw the spring clip securing the cable to the abutment bracket, and remove the cable from the caliper.

7 Undo the bolts and release the cable support clips on the suspension arm, chassis member and underbody (see illustrations).

8 Disconnect the return spring, extract the spring clip and withdraw the clevis pin securing the front handbrake cable to the compensator (see illustration).

9 Turn the rear cable end through 90°, and release it from the slot in the compensator.

10 Withdraw the cable from the abutment bracket, and remove it from under the car. Remove the support clips from the cable.

### Refitting

11 Refitting is a reversal of removal. Adjust the handbrake as described in Section 17 before lowering the car to the ground.

## 21 Stop-light switch - removal, refitting and adjustment



### Removal

1 From inside the car, release the turnbuckles and lift out the trim panel over the clutch, brake and accelerator pedals.



20.7b . . . and rear underbody

2 Disconnect the switch wiring multiplug, then slacken the locknut and unscrew the switch from the brake pedal bracket (see illustration).

### Refitting and adjustment

3 Refit the switch to the brake pedal bracket then adjust its position as follows.

4 Temporarily reconnect the wiring multiplug so that the switch terminals connected to the green/purple, and purple or purple/pink wires can be noted.

5 Remove the multiplug once more and connect an ohmmeter across the switch green/purple terminal, and purple or purple/pink terminal.

6 Turn the switch anti-clockwise until the ohmmeter reads zero. Now turn the switch clockwise until the ohmmeter reads infinity. On cars equipped with cruise control, turn the switch clockwise one further turn. On cars without cruise control, turn the switch clockwise a further half a turn. Hold the switch in this position and tighten the locknut.

7 Disconnect the ohmmeter and reconnect the switch wiring multiplug. Ensure that the multiplug is correctly connected otherwise the stop lights will illuminate whenever the ignition is switched on.

8 Refit the trim panel over the pedals.

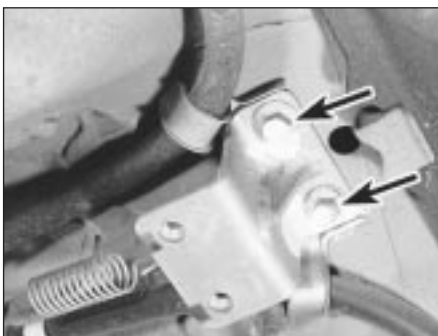

20.7c Front cable support retaining bolts (arrowed)

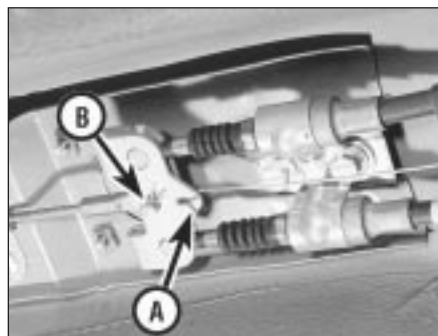

20.8 Handbrake cable return spring (A) and retaining clevis pin (B)

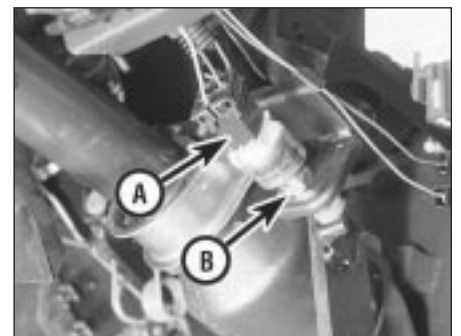

21.2 Stop-light switch wiring multiplug (A) and locknut (B)



**22 Vacuum servo unit - general information and testing**



**General information**

1 A vacuum servo unit is located between the brake pedal and master cylinder, to provide assistance to the driver when the brake pedal is depressed. This reduces the effort required by the driver to operate the brakes under all braking conditions.

2 The unit operates by vacuum obtained from the inlet manifold, and consists basically of a diaphragm, control valve and non-return valve.

3 With the brake pedal released, vacuum is channelled to both sides of the diaphragm, but when the pedal is depressed, one side is opened to atmosphere. The resultant unequal pressures are harnessed to assist in depressing the master cylinder pistons.

4 Normally, the servo unit is very reliable, but if the unit becomes faulty it must be renewed complete, as repair is not possible. In the event of failure, the hydraulic system is in no way affected, except that higher pedal pressures will be necessary.

**Testing**

5 To test the servo unit, depress the brake pedal several times with the engine switched off, to destroy the vacuum.

6 Apply moderate pressure to the brake pedal, then start the engine. The pedal should move down slightly as the vacuum is restored, if the servo is operating correctly.

7 Now switch off the engine and wait five minutes. Vacuum should still be available for at least one assisted operation of the pedal.

**23 Vacuum servo unit - removal and refitting**



**Removal**

1 Remove the master cylinder as described in Section 11.

2 From inside the car, release the turnbuckles and lift out the trim panel over the clutch, brake and accelerator pedals.

3 Extract the retaining clip and withdraw the clevis pin securing the servo pushrod to the brake pedal.

4 From within the engine compartment, remove the vacuum hose elbow from the front

face of the servo by prising it out of its grommet.

5 Unscrew the four retaining nuts inside the car, and withdraw the servo unit from the engine compartment bulkhead.

6 With the servo removed, the air filter can be renewed if necessary. Withdraw the dust cover over the air filter and pushrod. Hook out the washer and old filter, and cut the filter to allow removal over the pushrod fork. Similarly cut the new filter, place it in position in the housing, and refit the washer and dust cover.

**Refitting**

7 Refitting is a reversal of removal. Use a new gasket on the servo-to-bulkhead mating face, and tighten the retaining nuts to the specified torque. Refit the master cylinder as described in Section 11.

**24 Anti-lock braking system - general information**

Later Rover 800 series models are available with an anti-lock braking system (ABS) as standard equipment or an optional extra. The system is used in conjunction with the normal braking system to provide greater stability, improved steering control and shorter stopping distances under all braking conditions. Two different ABS systems have been used, the later type introduced for the 1992 model year, operates in basically the same way as the early system but incorporates modifications to the hydraulic modulator and electronic control unit. A brief description of the operation of both systems is as follows (see illustration). Each wheel is provided with a wheel speed sensor, which monitors the wheel rotational speed. The sensor consists of a magnetic core and coil, and is mounted at a predetermined distance from a toothed reluctor ring. The reluctor rings for the front wheels are pressed onto the driveshaft outer constant velocity joints, and those for the rear wheels are pressed onto the rear hubs. When each hub turns, the magnetic field of the sensor is altered as the reluctor ring teeth pass the sensor head, thus inducing an alternating voltage, the frequency of which varies according to wheel speed.

Signals from the wheel speed sensors are sent to an electronic control unit, which can accurately determine whether a wheel is accelerating or decelerating in relation to a reference speed. Information from the electronic control unit is sent to the hydraulic modulator which, on the early system, contains four solenoids each operating one inlet and one exhaust valve for each brake. On the later system, the modulator contains one solenoid for each front brake, plus one solenoid and a copy valve for the rear brakes. On both systems the solenoids all work independently of each other in three distinct phases:

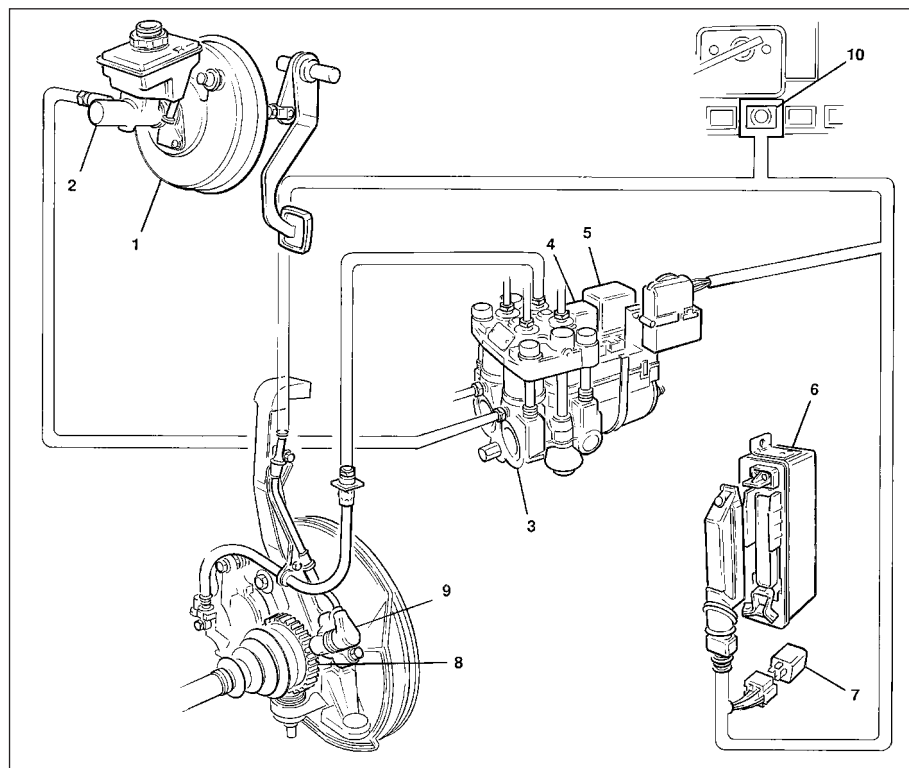

**24.1 Anti-lock braking system main components (pre-1992 model year version shown, later version similar)**

- |  |   |  |
|--|---|--|
| 1 Vacuum servo unit                                  | 5 Modulator control relay - return pump operation | 8 Front wheel speed sensor reluctor ring |
| 2 Master cylinder                                    | 6 Electronic control unit                         | 9 Front wheel speed sensor               |
| 3 Hydraulic modulator                                | 7 Over-voltage protection relay                   | 10 ABS warning light                     |
| 4 Modulator control relay - solenoid valve operation |   |  |

**Pressure build-up phase:** The solenoid inlet valves are open, and hydraulic pressure from the master cylinder is applied directly to the brake calipers.

**Constant pressure phase:** The solenoid inlet and exhaust valves are closed, and hydraulic pressure at the calipers is maintained at a constant level, even though master cylinder pressure may increase.

**Pressure reduction phase:** The solenoid inlet valve is closed to prevent further hydraulic pressure reaching the caliper and, in addition, the exhaust valve is open, to reduce existing pressure and release the brake. Fluid is returned to the master cylinder in this phase via the return pump in the hydraulic modulator.

The braking cycle for one wheel is therefore as follows, and will be the same for all four wheels, although independently.

Wheel rotational speed is measured by the wheel speed sensors, the information is processed by the electronic control unit. By comparing the signals received from each wheel, the control unit can determine a reference speed, and detect any variation from this speed, which would indicate a locking brake. Should a lock-up condition be detected, the control unit initiates the constant pressure phase, and no further increase in hydraulic pressure is applied to the affected brake. If the lock-up condition is still detected, the pressure reduction phase is initiated to allow the wheel to turn. The control unit returns to the constant pressure phase until the wheel rotational speed exceeds a predetermined value, then the cycle repeats with the control unit re-initiating the pressure build-up phase. This control cycle is continuously and rapidly repeated, until the brake pedal is released or the car comes to a stop.

Additional circuitry within the electronic control unit monitors the functioning of the system, and informs the driver of any fault condition by means of a warning light. Should a fault occur, the system switches off allowing normal braking, without ABS, to continue.

## 25 Anti-lock braking system - component removal and refitting



### ABS main relays

- 1 Disconnect the battery negative (earth) lead (refer to Chapter 5, Section 1).
- 2 Undo the screw and lift off the plastic cover over the hydraulic modulator.
- 3 Remove the relays by pulling them out of their location. The relay nearest the hydraulic pipe connection end of the modulator controls the solenoid valve operation, and the relay furthest away from the hydraulic pipe connections controls the return pump operation.
- 4 Refitting is the reversal of removal.

### Over-voltage protection relay

- 5 An over-voltage protection relay is only used on the early systems.
- 6 Disconnect the battery negative (earth) lead (refer to Chapter 5, Section 1).
- 7 Working in the luggage compartment, release the turnbuckle and lift off the cover over the electronic control unit.
- 8 Withdraw the relay from its socket which is located below the ECU on Saloon models, and to the side of the ECU, behind the trim panel on Fastback models.
- 9 Refitting is a reversal of removal.

### Electronic control unit

#### Early system

- 10 Disconnect the battery negative (earth) lead (refer to Chapter 5, Section 1).
- 11 Working in the luggage compartment on the left-hand side, release the turnbuckle and lift off the control unit cover.
- 12 Disconnect the wiring multiplug by depressing the spring tab at the cable end, lift the plug up at the cable end, then disengage the tab at the other end.
- 13 Undo the retaining bolts and remove the unit from its location.
- 14 Refitting is a reversal of removal, but ensure that the wiring multiplug engages securely with an audible click from the spring tab.

#### Later system

- 15 On the system fitted to later models, the ECU is attached to the hydraulic modulator.
- 16 Disconnect the battery negative (earth) lead (refer to Chapter 5, Section 1).
- 17 Undo the screw and lift off the plastic cover over the hydraulic modulator.
- 18 Release the metal clip securing the main wiring harness to the ECU then disconnect the three wiring multiplugs.

19 Undo the six Torx screws and withdraw the ECU from the top of the hydraulic modulator.

20 Refitting is a reversal of removal.

### Hydraulic modulator

**Note:** Before starting work, refer to the warning at the beginning of Section 2 concerning the dangers of hydraulic fluid.

#### Early system

- 21 Disconnect the battery negative (earth) lead (refer to Chapter 5, Section 1).
- 22 Undo the screw and lift off the plastic cover over the hydraulic modulator. Unscrew the cable clamp and disconnect the modulator wiring multiplug. Undo the earth terminal nut and disconnect the earth lead from the modulator (see illustration).
- 23 Remove the master cylinder reservoir filler cap, and place a piece of polythene over the filler neck. Seal the polythene with an elastic band, ensuring that an airtight seal is obtained. This will minimise brake fluid loss during subsequent operations. Place rags beneath the modulator as an added precaution against fluid spillage.
- 24 If no identification labels are present on the modulator brake pipe unions, identify each pipe and its location as an aid to refitting. The modulator ports should be stamped on the modulator body with a two-letter code as follows:  
VR Right-hand front  
VL Left-hand front  
HR Right-hand rear  
HL Left-hand rear
- 25 Unscrew each brake pipe union at the modulator, withdraw the pipe, and immediately plug the pipe end and orifice. Release the pipe support bracket from the side of the modulator, and carefully ease the pipes clear.

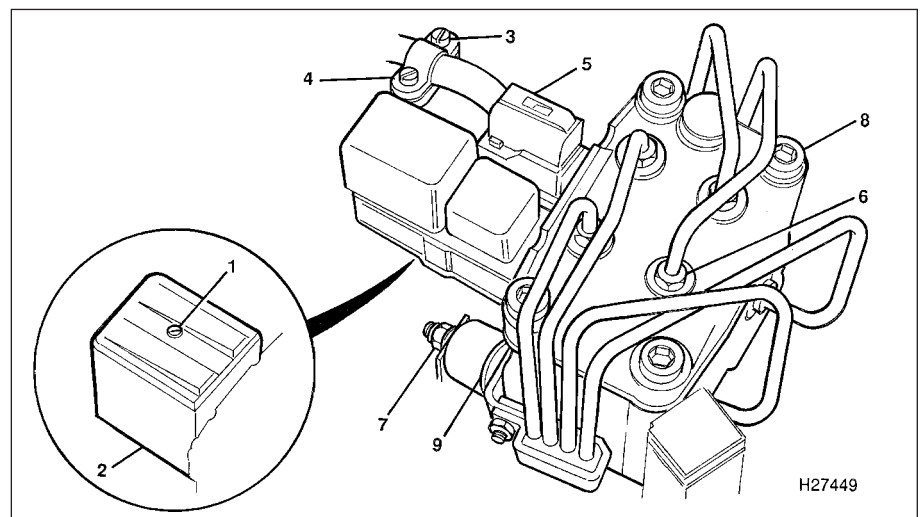

25.22 ABS hydraulic modulator attachments (early version shown)

- |                         |                     |                    |
|-------------------------|---------------------|--------------------|
| 1 Cover retaining screw | 4 Cable clamp       | 7 Mounting nuts    |
| 2 Modulator relay cover | 5 Multiplug         | 8 Modulator        |
| 3 Cable clamp screws    | 6 Brake pipe unions | 9 Mounting rubbers |

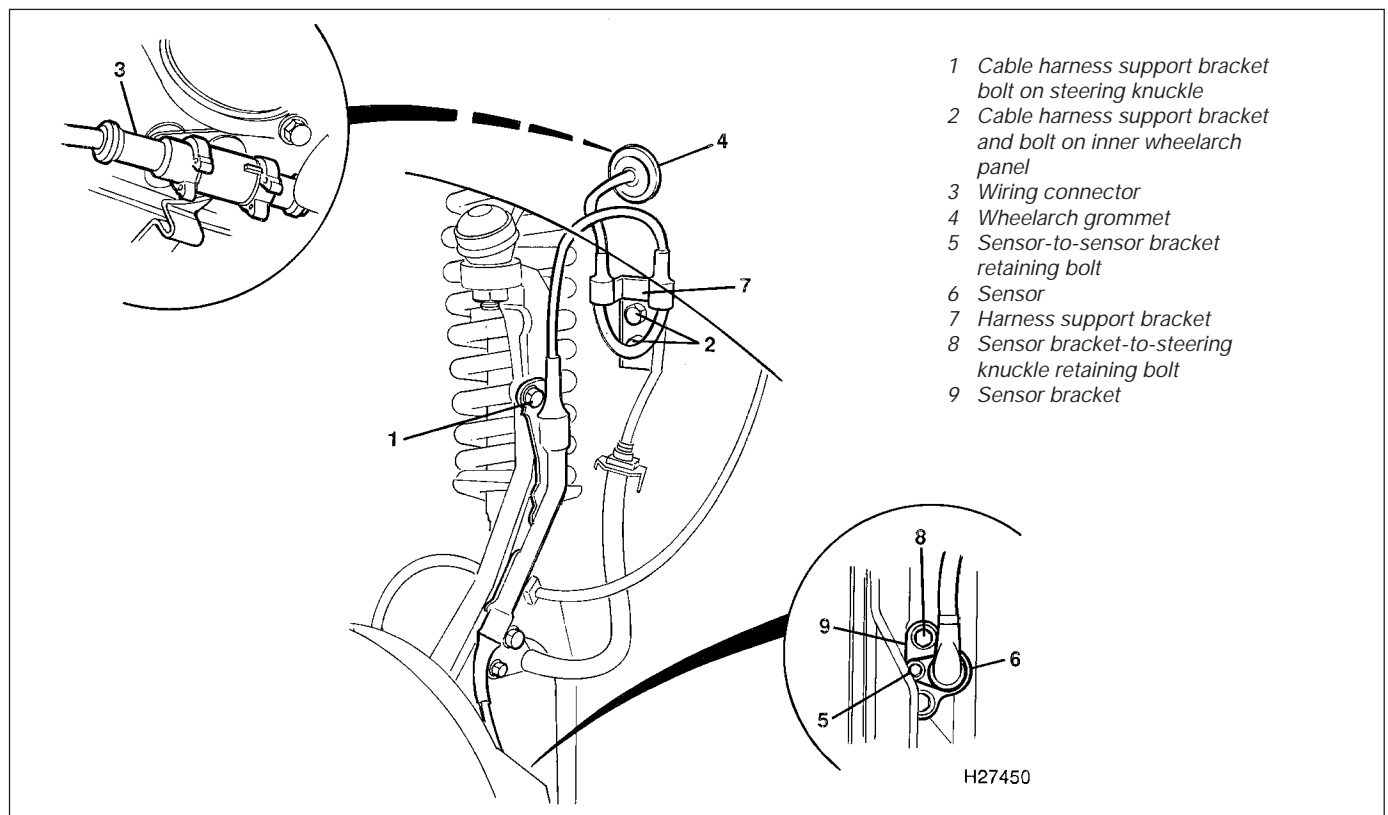

25.37 Front wheel speed sensor attachments

26 Slacken the modulator mounting nuts and remove the unit from its location. Do not attempt to dismantle the modulator, as it is a sealed unit, and no repairs are possible.

27 Refitting is a reversal of removal. Bleed the hydraulic system as described in Section 2 on completion.

**Later system**

28 Disconnect the battery negative (earth) lead (refer to Chapter 5, Section 1).

29 Remove the electronic control unit from the modulator as described previously.

30 Undo the earth terminal nut and disconnect the earth lead from the modulator.

31 Remove the master cylinder reservoir filler cap, and place a piece of polythene over the filler neck. Seal the polythene with an elastic band, ensuring that an airtight seal is obtained. This will minimise brake fluid loss during subsequent operations. Place rags beneath the modulator as an added precaution against fluid spillage.

32 If no identification labels are present on the modulator brake pipe unions, identify each pipe and its location as an aid to refitting. The modulator ports should be stamped on the modulator body with a two-letter code as follows:

- RF Right-hand front
- LF Left-hand front
- RR Right-hand rear
- LR Left-hand rear

33 Unscrew each brake pipe union at the modulator, withdraw the pipe, and immediately plug the pipe end and orifice.

34 Slacken the three modulator mounting nuts and remove the unit from its location. Do not attempt to dismantle the modulator, as it is a sealed unit, and no repairs are possible.

35 Refitting is a reversal of removal. Bleed the hydraulic system as described in Section 2 on completion.

**Front wheel speed sensor**

36 Apply the handbrake, remove the front wheel trim and slacken the wheel nuts. Jack up the front of the car and support it on axle stands. Remove the front roadwheel.

37 Undo the bolts securing the cable harness support brackets to the steering knuckle and inner wheel arch panel (see illustration).

38 From within the engine compartment, release the wiring connector from its holder, and separate the connector. Release the wheel arch grommet and pull the wiring through to the wheel arch.

39 Undo the bolt securing the sensor to the sensor bracket on the steering knuckle, and carefully prise the sensor out of the bracket.

40 Release the sensor wiring from the support bracket, and remove the unit from the car.

41 Undo the two bolts and remove the sensor bracket from the steering knuckle.

42 Prior to refitting, clean the sensor, sensor

bracket and the mounting area on the steering knuckle, removing all traces of dirt and grit.

43 Refitting is a reversal of removal. Lubricate the sensor and sensor bracket with Rocol J166 or Molykote FB180, and ensure that the bracket bosses face the hub when fitting. Tighten all bolts to the specified torque, and check the sensor-to-reluctor ring clearance, which should be as given in the Specifications.

**Rear wheel speed sensor**

44 Chock the front wheels, remove the rear wheel trim and slacken the wheel nuts. Jack up the rear of the car and support it on axle stands. Remove the rear roadwheel.

45 Working in the luggage compartment on the left-hand side, release the turnbuckle and lift off the cover over the electronic control unit (early systems only) (see illustration).

46 Remove the left-hand side inner trim panel.

47 Disconnect the wheel speed sensor wiring at the cable connector.

48 Undo the two screws and remove the plastic liner on the front face of the rear wheel arch.

49 Release the grommets in the luggage compartment floor and inner wheel arch, then pull the wiring through to the wheel arch.

50 Undo the two bolts and remove the cable cover and guide from the chassis member.

51 Release the cable ties and retaining clips

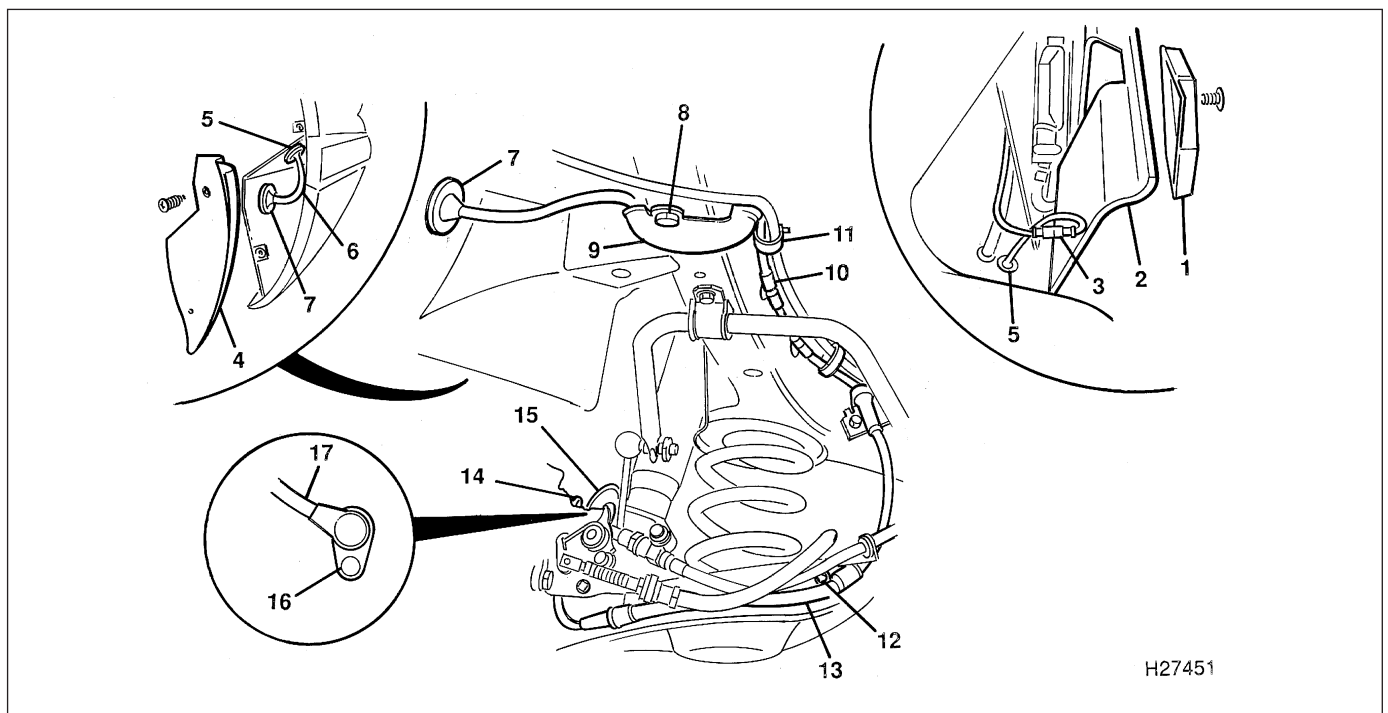

#### 25.45 ABS rear wheel speed sensor attachments

- |                                     |                           |  |
|-------------------------------------|---------------------------|--|
| 1 Electronic control unit cover     | 7 Inner wheelarch grommet | 13 Cable harness support bracket on suspension arm |
| 2 Left-hand side trim panel         | 8 Cover bolts             | 14 Handbrake linkage cover bolts                   |
| 3 Cable connector                   | 9 Cable cover and guide   | 15 Handbrake linkage cover                         |
| 4 Rear wheelarch plastic liner      | 10 Cable retaining clip   | 16 Sensor-to-bracket retaining bolt                |
| 5 Luggage compartment floor grommet | 11 Cable tie              | 17 Wheel speed sensor                              |
| 6 Sensor wiring                     | 12 Support bracket bolt   |  |

securing the sensor wiring to the chassis member.

**52** Undo the three bolts securing the cable harness support bracket to the rear suspension arm.

**53** Undo the three bolts and remove the handbrake linkage cover from the brake caliper.

**54** Undo the bolt securing the sensor to the sensor bracket on the hub carrier, and carefully prise the sensor out of the bracket.

**55** Manipulate the sensor and wiring out from under the wheelarch, and remove it from car.

**56** Prior to refitting, clean the sensor, sensor

bracket and the mounting area on the hub carrier, removing all traces of dirt and grit.

**57** Refitting is a reversal of removal. Lubricate the sensor and sensor bracket with Rocol J166 or Molykote FB180, and tighten all bolts to the specified torque. Check the sensor-to-reluctor ring clearance, which should be as given in the Specifications.

#### Wheel speed sensor reluctor rings

**58** The reluctor rings for the front and rear wheel speed sensors are an integral part of the driveshaft outer constant velocity joints

(front) and rear wheel hub flanges (rear), and cannot be renewed separately.

**59** If a reluctor ring is damaged, or in any way unserviceable, a new driveshaft outer constant velocity joint or rear hub flange must be obtained as applicable. Removal and refitting procedures are covered in Chapters 8 and 10 respectively.

#### ABS copy valve

**60** Removal and refitting procedures for the copy valve fitted to the later type ABS system are the same as those for the pressure-reducing valve used on the standard braking system. Refer to Section 14 for details.







# Chapter 10

## Suspension and steering systems

### Contents

Ancillary drivebelts check and renewal . . . . .	See Chapter 1	Rear coil spring - removal and refitting . . . . .	14
Front anti-roll bar - removal and refitting . . . . .	9	Rear hub bearing - renewal . . . . .	12
Front hub bearing - renewal . . . . .	3	Rear hub carrier - removal and refitting . . . . .	11
Front lower suspension arm - removal and refitting . . . . .	8	Rear shock absorber - removal and refitting . . . . .	13
Front shock absorber and coil spring assembly - dismantling and reassembly . . . . .	6	Rotary coupler - removal and refitting . . . . .	19
Front shock absorber and coil spring assembly - removal and refitting . . . . .	5	Steering column - removal and refitting . . . . .	21
Front steering knuckle assembly - removal and refitting . . . . .	2	Steering column lock - removal and refitting . . . . .	20
Front tie-bar - removal and refitting . . . . .	10	Steering gear - removal and refitting . . . . .	24
Front upper suspension arm - removal and refitting . . . . .	7	Steering gear rubber gaiter - renewal . . . . .	23
General information . . . . .	1	Steering knuckle balljoint - removal and refitting . . . . .	4
Power steering gear - bleeding . . . . .	25	Steering, suspension and roadwheel check . . . . .	See Chapter 1
Power steering fluid cooler - removal and refitting . . . . .	27	Steering track rod - removal and refitting . . . . .	22
Power steering fluid level check . . . . .	See Chapter 1	Steering wheel - removal and refitting . . . . .	18
Power steering pump - removal and refitting . . . . .	26	Trailing link - removal and refitting . . . . .	16
Rear anti-roll bar - removal and refitting . . . . .	17	Transverse link - removal and refitting . . . . .	15
		Tyre condition and tyre pressure checks . . . . .	See Chapter 1
		Wheel alignment and steering angles - general information . . . . .	28

### Degrees of difficulty

<b>Easy</b> , suitable for novice with little experience 	<b>Fairly easy</b> , suitable for beginner with some experience 	<b>Fairly difficult</b> , suitable for competent DIY mechanic 	<b>Difficult</b> , suitable for experienced DIY mechanic 	<b>Very difficult</b> , suitable for expert DIY or professional 
---	--	--	---	--

### Specifications

#### Front suspension

Type . . . . .	Independent, by unequal length upper and lower suspension arms, with coil springs, telescopic shock absorbers and anti-roll bar
Hub bearing endfloat . . . . .	0.05 mm

#### Rear suspension

Type . . . . .	Independent, by transverse and training links, with coil springs, telescopic shock absorbers and anti-roll bar. Self-levelling suspension optional on certain models
Hub bearing endfloat . . . . .	0.10 mm

#### Steering

Type . . . . .	Power-assisted rack and pinion
Turns lock-to-lock:	
4-cylinder engine models without turbo . . . . .	3.12
4-cylinder turbo engine models . . . . .	2.97
V6 engine models . . . . .	3.36

#### Front and rear wheel alignment

Front wheel toe setting:	
Pre-1992 model year . . . . .	Parallel $\pm$ 0° 8'
1992 model year onward . . . . .	Parallel $\pm$ 0° 15'
Rear wheel toe setting:	
Pre-1992 model year . . . . .	0° 10' $\pm$ 0° 4' toe-in
1992 model year onward . . . . .	0° 22' $\pm$ 0° 15' toe-in

#### Roadwheels

Type . . . . .	Pressed steel or light alloy
Wheel size:	
4-cylinder engine models . . . . .	6J x 14, 6J x 15, 6J x 16 or 7J x 17 (3.5J x 15 space saver spare wheel)
V6 engine models . . . . .	6J x 15 or 6J x 16 (3.5J x 15 space saver spare wheel)

## 10•2 Suspension and steering systems

### Tyres

Tyre size:

4-cylinder engine models	195/70 VR 14, 195/65 VR 15, 205/55 VR 16 or 215/45 ZR 17 (115/70 R 15 space saver)
V6 engine models	195/65 VR 15, 205/60 VR 15 or 205/55 VR 16 (115/70 R 15 space saver)

Tyre pressures See Chapter 1 Specifications

### Torque wrench settings

	Nm	lbf ft
<b>Front suspension</b>		
Anti-roll bar connecting link bolts	50	37
Anti-roll bar mounting bracket bolts	22	16
Driveshaft retaining nut	415	306
Upper suspension arm balljoint nut	50	37
Strut forked member to lower arm	90	66
Strut forked member clamp bolt	60	44
Shock absorber top mounting nuts	25	18
Shock absorber spindle nut	50	37
Upper suspension arm mounting nuts	80	59
Upper suspension arm pivot bolt	90	66
Lower suspension arm inner mounting bolt	50	37
Tie-bar front mounting nut	90	66
Tie-bar to lower suspension arm bolts	170	125
Longitudinal support member bolts	45	33
<b>Rear suspension</b>		
Anti-roll bar connecting link nuts	45	33
Anti-roll bar mounting bracket bolts	22	16
Hub carrier to trailing link bolt	70	52
Hub carrier to transverse link bolt	70	52
Shock absorber to hub carrier clamp bolt	70	52
Shock absorber upper mounting nuts	25	18
Shock absorber spindle nut	52	38
Hub flange retaining nut	245	181
Transverse link inner mounting bolt	50	37
Trailing link front mounting nut	45	33
Trailing link adjustment plate retaining bolt	70	52
Trailing link adjustment plate eccentric bolt	70	52
<b>Steering</b>		
Steering wheel nut	50	37
Air bag module to steering wheel bolts	8	6
Steering column upper mounting nuts	14	10
Steering column lower mounting bolts	22	16
Column universal joint clamp bolts	22	16
Steering track rod balljoint nut	44	32
Steering track rod locknut	45	33
Steering rack hydraulic unions	20	15
Steering gear mounting bolts	45	33
Steering gear lower cover plate bolts (V6 engine)	10	7
Steering knuckle balljoint nut	100	74
Power steering pump retaining bolts:		
4-cylinder engine - rear-mounted pump	25	18
4-cylinder engine - front-mounted pump:		
Early version (4 mounting bolts)	10	7
Later version (5 mounting bolts)	25	18
V6 engine:		
Mounting bolt	39	29
Adjusting nut	22	16
Power steering pump pulley nut/bolt:		
4-cylinder engine - rear-mounted pump	82	61
4-cylinder engine - front-mounted pump	25	18
V6 engine	33	24
Power steering pump drivebelt tensioner wheel retaining nut (4-cylinder engine - rear mounted pump)	45	33
Power steering pump high pressure pipe connector bolts (V6 engine)	11	8
<b>Roadwheels</b>		
Roadwheel nuts	110	81

### 1 General information

The independent front suspension is by unequal length upper and lower suspension arms, and utilizes coil springs and telescopic shock absorbers (see illustration). Each spring and shock absorber assembly is attached to the body turret at its upper end by a rubber-cushioned mounting, and to the lower suspension arm by a forged, forked-shaped member. Fore and aft location of each suspension assembly is by a tie-bar, and an anti-roll bar is used to minimise body roll. The front steering knuckles, which carry the hub bearings, brake calipers and the hub/disc assemblies, pivot on balljoints - one incorporated in the upper suspension arm, and one secured to the lower part of the steering knuckle itself.

The independent rear suspension is by transverse and trailing links with coil springs, telescopic shock absorbers, and an anti-roll bar (see illustration). The shock absorbers are attached to the body at their upper ends by rubber-cushioned mountings, and clamped to the hub carriers at their lower ends. Lateral location of each suspension assembly is provided by the transverse link, which also provides the lower location of the coil spring. Fore and aft location of each suspension assembly is controlled by the trailing link, which is attached to the hub carrier by means of a bracket incorporating an eccentric mounting bolt for rear wheel toe adjustment.

Self-levelling rear suspension, which reacts to vehicle loading and automatically maintains the normal trim heights, is available on certain models. The self-levelling units are sealed dampers fitted in place of the normal rear shock absorbers. A pump in the damper operates under the action of the suspension to raise the rear of the car until normal trim height is regained. On an undulating road, this process will be carried out within one mile. When the additional load is removed, the suspension remains at the correct level.

Power-assisted rack and pinion steering gear is standard equipment on all models. Movement of the steering wheel is transmitted to the steering gear by a steering column shaft containing two universal joints (see illustration). These allow for provision of a rake-adjustable column assembly, and also allow the necessary upward deflection of the column, for driver safety, in the event of front end impact. The front wheels are connected to the steering gear by track rods, each having an inner and outer balljoint. On early 4-cylinder engine models, hydraulic fluid pressure for the power assistance is provided by a pump, mounted on the left-hand end of the engine and belt-driven from a pulley on the inlet camshaft. On later 4-cylinder, and all V6 engine models, the pump is mounted at the timing belt end of the engine and is belt-driven from the crankshaft pulley.

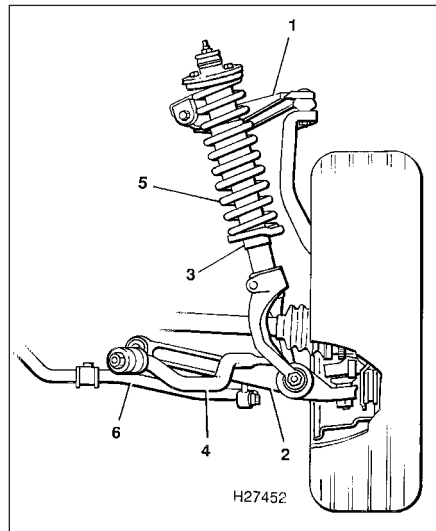

1.1 Front suspension assembly

- |                        |                 |
|------------------------|-----------------|
| 1 Upper suspension arm | 4 Tie-bar       |
| 2 Lower suspension arm | 5 Coil spring   |
| 3 Shock absorber       | 6 Anti-roll bar |

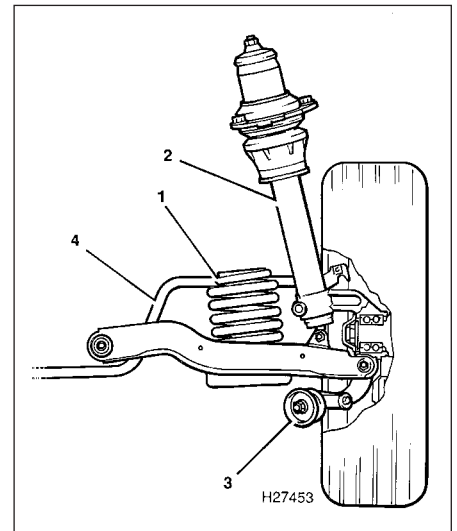

1.2 Rear suspension assembly

- |                  |                 |
|------------------|-----------------|
| 1 Coil spring    | 3 Trailing link |
| 2 Shock absorber | 4 Anti-roll bar |

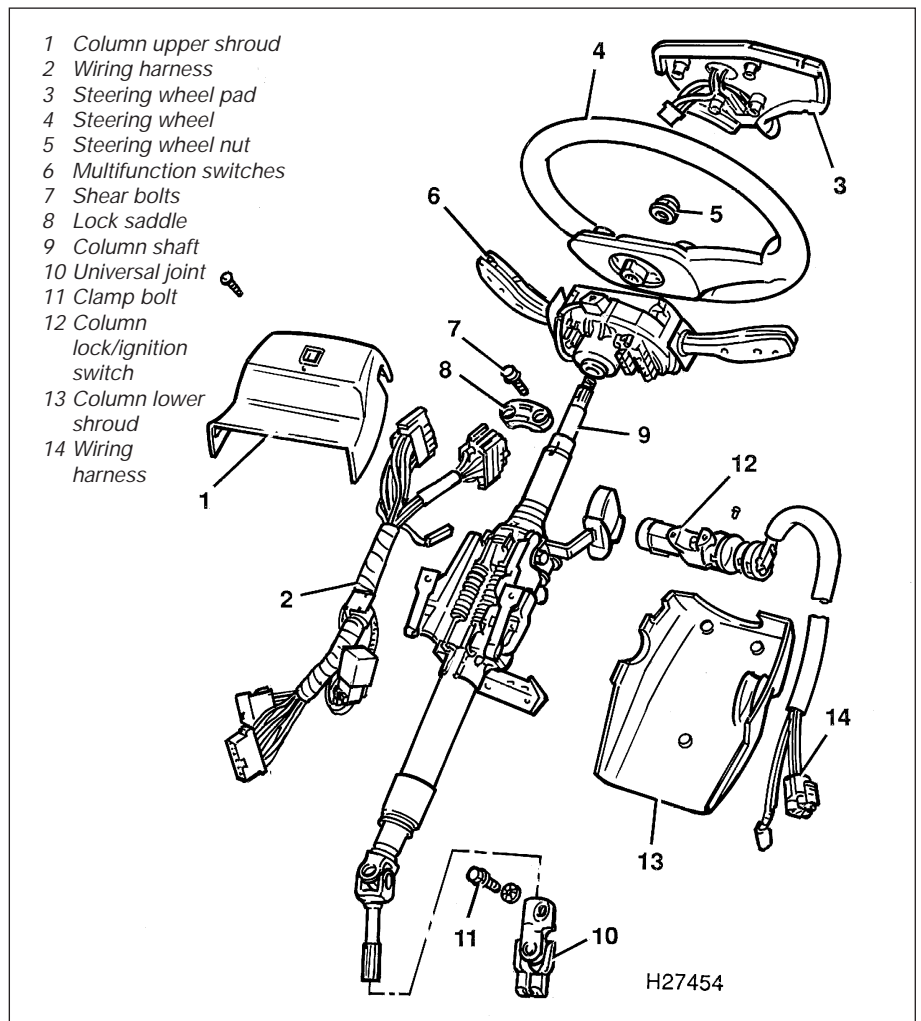

1.4 Exploded view of the steering column components



2.2 Knock up the staking (arrowed) securing the driveshaft retaining nut

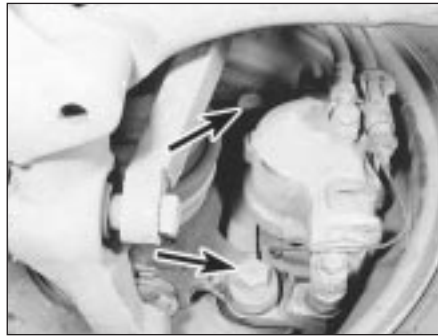

2.6 Brake caliper carrier bracket securing bolts (arrowed)



2.8 Brake disc retaining screws (arrowed)

## 2 Front steering knuckle assembly - removal and refitting



**Note:** A new driveshaft retaining nut will be required for refitting.

### Removal

1 While the car is standing on its wheels, firmly apply the handbrake and put the transmission in gear (PARK on automatic models).

2 Remove the wheel trim, and using a small punch, knock up the staking that secures the driveshaft retaining nut to the groove in the constant velocity joint stub shaft (see



2.10 Extract the track rod balljoint nut split pin (arrowed)

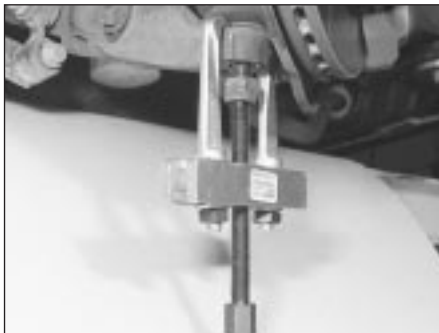

2.11 Using a two-legged puller to release the steering knuckle balljoint

**illustration**). Note that a new retaining nut will be needed for reassembly.

3 Using a socket, sturdy T-bar and long extension tube for leverage, slacken the retaining nut half a turn. Note that the retaining nut is tightened to a very high torque setting, and considerable effort will be required to slacken it.

4 Slacken the wheel nuts, jack up the front of the car and support it on stands. Remove the roadwheel and put the transmission in neutral.

5 Remove the driveshaft retaining nut.

6 Undo the two bolts securing the brake caliper carrier bracket to the steering knuckle, and the two bolts securing the brake hose bracket to the knuckle (see **illustration**).

7 Withdraw the caliper and carrier bracket assembly, complete with brake pads, off the disc, and tie it up using string or wire from a convenient place under the wheelarch. Take care to avoid straining the brake hose.

8 Undo the two retaining screws and remove the disc from the hub flange (see **illustration**).

9 On cars with ABS brakes, remove the front wheel speed sensor and wiring harness from the steering knuckle, as described in Chapter 9.

10 Extract the split pin and unscrew the nut securing the steering track rod balljoint to the steering knuckle arm (see **illustration**). Release the balljoint from the arm using a universal balljoint separator tool.

11 Undo the nut securing the steering knuckle balljoint to the lower suspension arm.



2.12 Undo the upper suspension arm balljoint nut (arrowed)

Release the balljoint from the arm using a separator tool or two-legged puller (see **illustration**).

12 Undo the nut securing the upper suspension arm balljoint to the steering knuckle, and release the balljoint using the same procedure as for the lower balljoint (see **illustration**).

13 Disengage the balljoint shanks, then withdraw the steering knuckle from the driveshaft (see **illustration**). If necessary, tap the end of the driveshaft with a copper or plastic mallet to release it from the hub splines. Remove the steering knuckle assembly from the car.

### Refitting

14 Refitting the steering knuckle is a reversal of removal, bearing in mind the following points:

- (a) Tighten all retaining nuts and bolts to the specified torque and use a new split pin to secure the steering track rod balljoint nut.
- (b) Use a new driveshaft retaining nut but do not attempt to tighten this nut fully until the weight of the car is on the roadwheels (see **illustration**). Peen the nut into the driveshaft groove using a small punch after tightening. If a torque wrench capable of recording the high figure required for tightening is not available, it is recommended that the old nut is fitted, tightened as securely as possible, then



2.13 Withdrawing the steering knuckle from the driveshaft





**2.14** Tighten the new driveshaft retaining nut fully only when the weight of the car is on the roadwheels

*peened into place. Take the car directly to a suitably-equipped garage, and have them fit and tighten the new nut for you.*

(c) On cars equipped with ABS brakes, refit the wheel speed sensor as described in Chapter 9.

### 3 Front hub bearing - renewal



**1** Remove the steering knuckle from the car as described in the previous Section.

**2** Support the steering knuckle on blocks with the hub flange facing downwards. Using a hammer and socket, or tube, in contact with the inner edge of the hub flange, drive the flange out of the hub bearing (see illustration). Alternatively, if a press is available, support the steering knuckle on the press bed and press the hub flange out (see illustration).

**3** As the hub flange is withdrawn, one of the bearing inner races will come away with it, and must now be removed. To do this, engage the legs of a two-legged puller under the inner race and draw it off. It may be easier to do this if a horseshoe-shaped strip of metal is placed under the inner race, to give the puller legs greater purchase (see illustration).

**4** With the hub flange removed, undo the four screws and remove the disc shield.

**5** Using circlip pliers, extract the bearing retaining circlip from the steering knuckle.

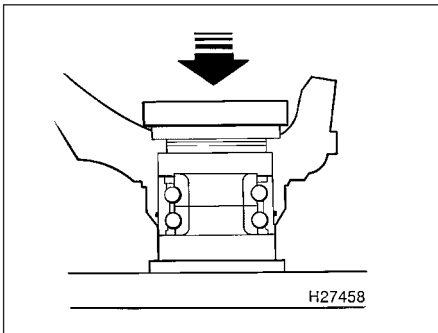

**3.7** Fitting the new hub bearing to the steering knuckle

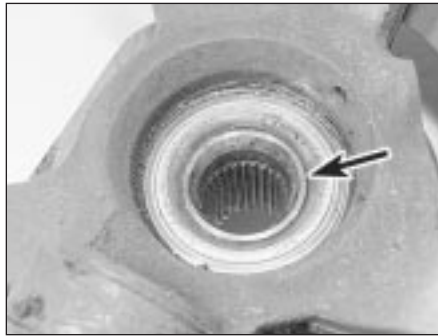

**3.2a** Remove the hub flange using a socket or tube in contact with its outer edge (arrowed) . . .

**6** Support the steering knuckle face-down on blocks, or on the press bed as before, and with the tube or mandrel in contact with the edge of the outer bearing, drive or press the bearing out (see illustration).

**7** Fit the new bearing in the same way, ensuring that it is pressed fully home to the shoulder in the steering knuckle (see illustration). Keep the bearing square as it is fitted, otherwise it will jam and continued pressure could cause the outer race to crack. If the bearing does jam, tap or press it out, remove any burrs in the bore of the steering knuckle and try again.

**8** Secure the bearing with the circlip, then refit the disc shield.

**9** Support the bearing inner race on a socket

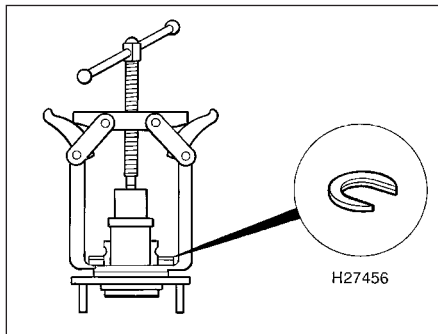

**3.3** Using a puller and horseshoe-shaped strip of metal to draw off the bearing inner race from the hub flange

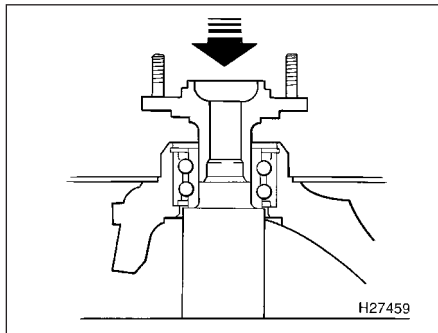

**3.9** Fitting the hub flange to the new bearing

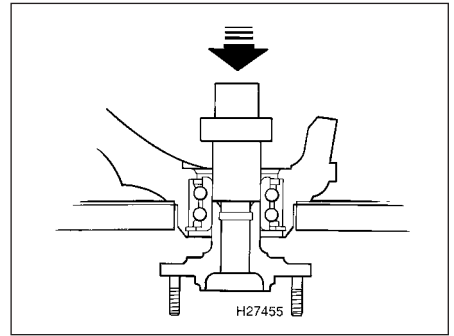

**3.2b** . . . or preferably support the steering knuckle on a press bed and press the hub flange out using a mandrel

or tube, and drive or press the hub flange into place (see illustration).

**10** The steering knuckle can now be refitted to the car as described in the previous Section.

### 4 Steering knuckle balljoint - removal and refitting



#### Removal

**1** Remove the steering knuckle from the car as described in Section 2.

**2** Extract the balljoint retaining circlip and remove the dust cover (see illustration).

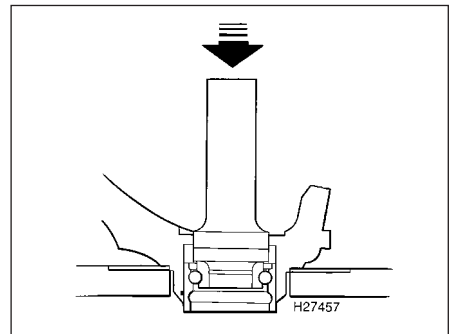

**3.6** Removing the hub bearing from the steering knuckle



**4.2** Balljoint retaining circlip (arrowed)

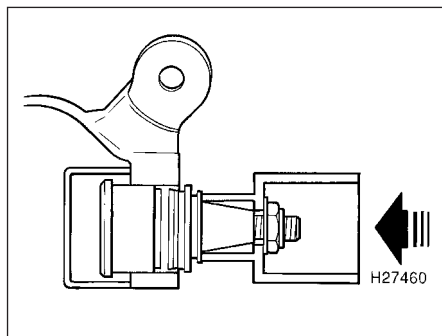

4.3 Rover special tool for steering knuckle balljoint removal

3 Support the steering knuckle in a wide-opening vice or on a press bed, and using tubes as mandrels and distance pieces, press the balljoint out of the knuckle. The manufacturer's special tools being used for this purpose are shown, to give an idea of the arrangement, but lengths of tubular steel work equally well (see illustration).

### Refitting

- 4 Using the same basic procedure as for removal, fit the new balljoint until its shoulder contacts the steering knuckle flange.
- 5 Fit the new dust cover and secure the assembly with the circlip.
- 6 Refit the steering knuckle to the car as described in Section 2.

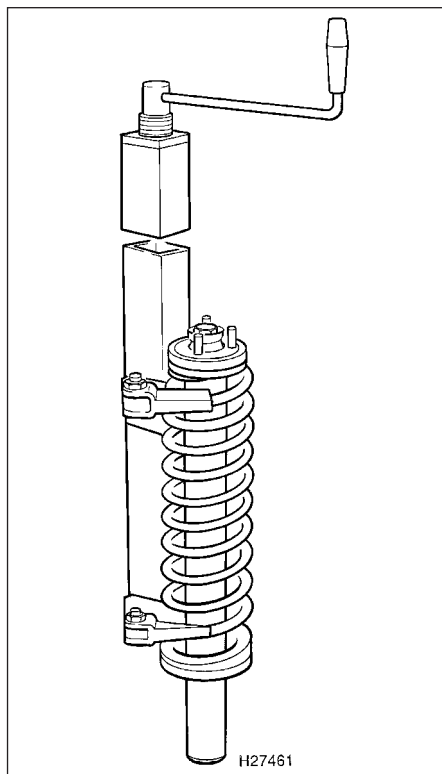

6.2 Coil spring and shock absorber assembly, showing spring compressor tool in position



5.5 Removing the front suspension forked member

## 5 Front shock absorber and coil spring assembly - removal and refitting

### Removal

- 1 Apply the handbrake, prise off the front wheel trim and slacken the wheel nuts. Jack up the front of the car and support it on axle stands. Remove the front roadwheel.
- 2 Place a jack beneath the lower suspension arm and raise the arm slightly.
- 3 Undo the nut and remove the through-bolt securing the forked member to the lower suspension arm.
- 4 Undo the nut and remove the clamp bolt securing the forked member to the shock absorber.
- 5 Slowly lower the jack, and remove the forked member from the shock absorber and lower suspension arm (see illustration). It may be necessary to tap the member down using a copper or plastic mallet to release it from the shock absorber.
- 6 Have an assistant hold the assembly, from below, then undo the three nuts securing the shock absorber top mounting to the body turret in the engine compartment (see illustration).
- 7 Remove the shock absorber and spring assembly from under the wheelarch.

### Refitting

- 8 Refitting is a reversal of removal. Tighten all nuts and bolts to the specified torque, but do



6.3 Remove the retaining nut (arrowed) from the shock absorber spindle

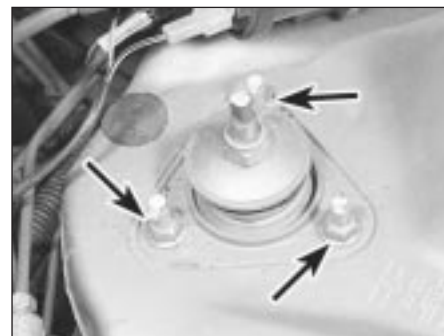

5.6 Shock absorber top mounting retaining nuts (arrowed)

not fully tighten the forked member-to-lower arm bolt and nut until the weight of the car is on the roadwheels.

## 6 Front shock absorber and coil spring assembly - dismantling and reassembly



**Warning:** Before attempting to dismantle the shock absorber and coil spring assembly, a tool to hold the spring in

compression must be obtained. Adjustable coil spring compressors are readily available, and are recommended for this operation. Any attempt at dismantling without such a tool is likely to result in damage or personal injury.

### Dismantling

- 1 Remove the shock absorber and coil spring assembly as described in the previous Section.
- 2 Position the spring compressors on either side of the spring, and compress the spring evenly until there is no tension on the spring seat or upper mounting (see illustration).
- 3 Hold the unthreaded end of the shock absorber spindle with a self-locking wrench or similar tool, and unscrew the upper mounting retaining nut (see illustration).
- 4 Withdraw the washer under the nut, followed by the upper bush, the upper mounting plate and the spring seat.
- 5 To remove the threaded collar on the shock absorber spindle, it will be necessary to make up a tool which will engage in the slots on the collar, enabling it to be unscrewed. A tool can

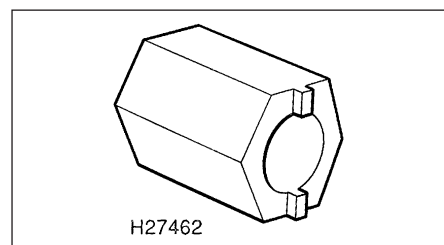

6.5 Shock absorber threaded collar home-made removal tool

be made out of a large nut, with one end suitably shaped by cutting or filing so that two projections are left, which will engage with the collar slots (see illustration).

6 Engage the home-made tool with the threaded collar slots, then screw two 10 mm nuts onto the threaded end of the spindle, and lock them together. Hold these locknuts to prevent the spindle turning, and unscrew the threaded collar.

7 Remove the locknuts, home-made tool and collar, then withdraw the lower bush and washer.

8 Lift off the spring, then remove the bump-stop and shock absorber dust cover.

9 Examine the shock absorber for signs of fluid leakage. Check the spindle for signs of wear or pitting along its entire length, and check the shock absorber body for signs of damage or corrosion. Test the operation of the shock absorber, while holding it in an upright position, by moving the spindle through a full stroke, and then through short strokes of 50 to 100 mm. In both cases, the resistance felt should be smooth and continuous. If the resistance is jerky or uneven, or if there is any visible sign of wear, damage or fluid leakage, renewal is necessary.

10 If any doubt exists about the condition of the coil spring, remove the spring compressors and check the spring for distortion or damage. The spring free length can only be assessed by comparing it with a new item, and this should be done if the

spring is suspect. Renew the spring if necessary, ideally in pairs (both sides).

11 Check the condition of the spring seat and upper mounting components, and renew any parts which are suspect.

**Reassembly**

12 Begin reassembly by refitting the shock absorber dust cover and bump-stop.

13 Refit the spring compressors, if previously removed, and place the spring in position on the shock absorber.

14 Refit the washer, lower bush and threaded collar. Tighten the collar using the same procedure as for removal.

15 Refit the spring seat, upper mounting plate, upper bush and washer. Secure the upper mounting assembly with the retaining nut, tightened to the specified torque.

16 Remove the spring compressors, and refit the spring and shock absorber to the car as described in Section 5.

**7 Front upper suspension arm - removal and refitting**



*Note: The upper suspension arm incorporates the steering knuckle upper support balljoint as a riveted integral assembly. If wear of the balljoint necessitates renewal, a complete upper suspension arm must be obtained.*

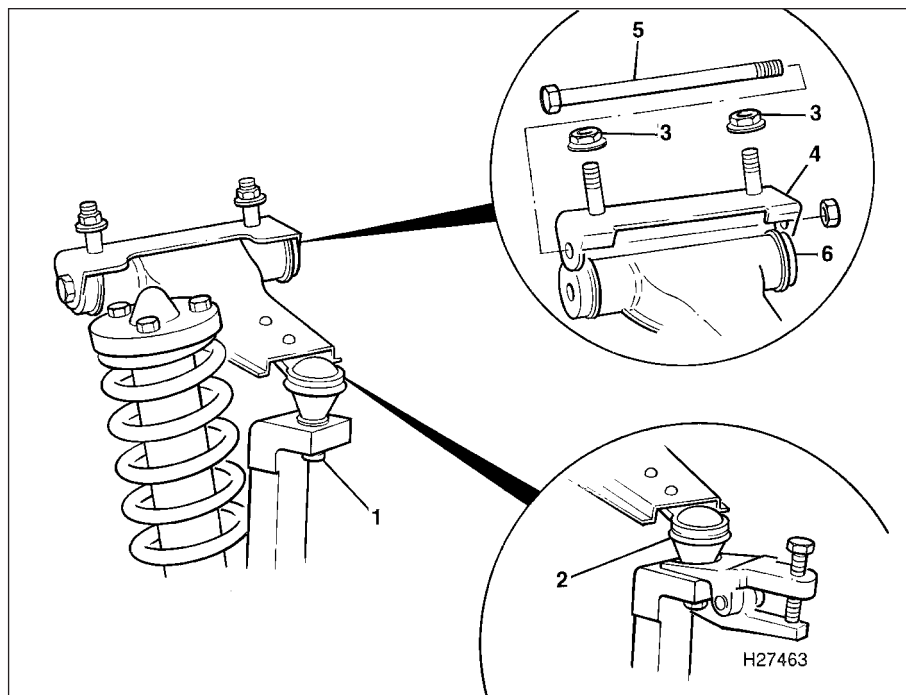

7.2a Upper suspension arm attachment details

- |   |                        |
|---|------------------------|
| 1 Balljoint-to-steering knuckle retaining nut   | 4 Mounting bracket     |
| 2 Releasing the balljoint with a separator tool | 5 Pivot bolt           |
| 3 Mounting bracket retaining nuts               | 6 Upper suspension arm |

**Removal**

1 Apply the handbrake, prise off the front wheel trim and slacken the wheel nuts. Jack up the front of the car and support it on axle stands. Remove the front roadwheel.

2 Undo the nut securing the upper suspension arm balljoint to the steering knuckle (see illustrations). Release the balljoint using a separator tool or two-legged puller.

3 From within the engine compartment, undo the two nuts securing the suspension arm mounting bracket to the inner wing valance. For access to the rearmost nut, it may be necessary to move the wiring harness connectors aside, or if working on the left-hand suspension arm, to undo the bolts and move the wiper motor bracket slightly.

4 Withdraw the upper suspension arm assembly from under the wheelarch.

5 With the arm on the bench, undo the nut and withdraw the pivot bolt then remove the arm from its mounting bracket.

6 Check the condition of the balljoint dust cover, and check the balljoint for excess free play. Also check the condition of the pivot bushes and the arm itself. The bushes can be renewed by drifting them out then pressing in new ones. If the balljoint, balljoint dust cover or the suspension arm show signs of damage or wear, a complete new assembly must be obtained. Examine the pivot bolt for signs of wear ridges, and check the mounting bracket for elongation of the pivot bolt holes. Renew any components as necessary.

**Refitting**

7 Refitting is a reversal of removal, but tighten all nuts and bolts to the specified torque.

**8 Front lower suspension arm - removal and refitting**



**Removal**

1 Apply the handbrake, prise off the front wheel trim and slacken the wheel nuts. Jack up the front of the car and support it on axle stands. Remove the front roadwheel.



7.2b Undo the nut securing the upper arm balljoint to the steering knuckle (arrowed)



**8.2 Undo the nut securing the steering knuckle balljoint to the lower suspension arm**

2 Undo the nut securing the steering knuckle balljoint to the lower suspension arm (see illustration). Release the balljoint using a separator tool or two-legged puller.

3 Undo the nut and remove the through-bolt securing the shock absorber forked member to the arm.

4 Undo the bolt securing the anti-roll bar connecting link to the arm.

5 Undo the two bolts securing the tie-bar to the arm.

6 Undo the nut and remove the suspension arm inner mounting bolt (see illustration).

7 Withdraw the suspension arm from its inner mounting location, and remove it from under the wheelarch.

8 Check the condition of the two suspension arm bushes, and renew these if worn or damaged. To do this, a press will be required,

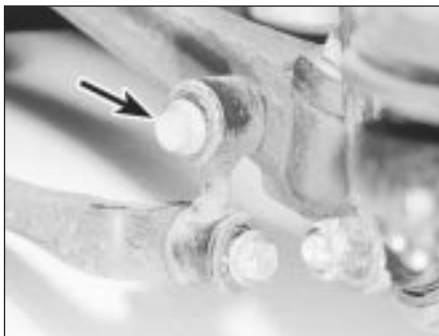

**9.2 Anti-roll bar connecting link bolt (arrowed)**



**9.3 Anti-roll bar mounting bracket bolts (arrowed)**



**8.6 Lower suspension arm inner mounting bolt (arrowed)**

together with mandrels and distance tubes. If this equipment is not available, have this work done by a Rover dealer or suitably-equipped garage.

### Refitting

9 Refitting is a reversal of removal, but tighten all nuts and bolts to the specified torque. Do not fully tighten the inner mounting bolt or the forked member retaining bolt until the weight of the car is on its roadwheels.

## 9 Front anti-roll bar - removal and refitting

### Removal

1 Apply the handbrake, prise off the front wheel trims and slacken the wheel nuts. Jack up the front of the car and support it on axle stands. Remove the front roadwheels.

2 Undo the single bolt each side securing the anti-roll bar connecting links to the lower suspension arms (see illustration).

3 Undo the two bolts each side securing the anti-roll bar mounting brackets to the chassis members, and remove the bar from under the car (see illustration).

4 If required, the connecting links can be removed after undoing the retaining nut and bolt on each side.

5 Check the condition of the connecting link bushes and the anti-roll bar mounting bushes, and renew any that show signs of deterioration. The connecting link bushes come complete with new connecting links, and the mounting bushes are slit along their length to allow removal and refitting over the bar.

### Refitting

6 Refitting is a reversal of removal. Tighten the mounting and connecting link bushes to the specified torque only with the weight of the car on its roadwheels.

## 10 Front tie-bar - removal and refitting



**Note:** On some models, it may be found that the tie-bar-to-lower suspension arm bolts cannot be withdrawn because of the proximity of the driveshaft. In this case, it will be necessary to release the lower suspension arm balljoint and disconnect the arm from the shock absorber, as described in Section 8.

### Removal

1 Apply the handbrake, prise off the front wheel trim and slacken the wheel nuts. Jack up the front of the car and support it on axle stands. Remove the front roadwheel.

2 Undo the five bolts and remove the undertray for access to the tie-bar front mounting.

3 Undo the front mounting nut and remove the tie-bar washer and outer mounting bush (see illustration).

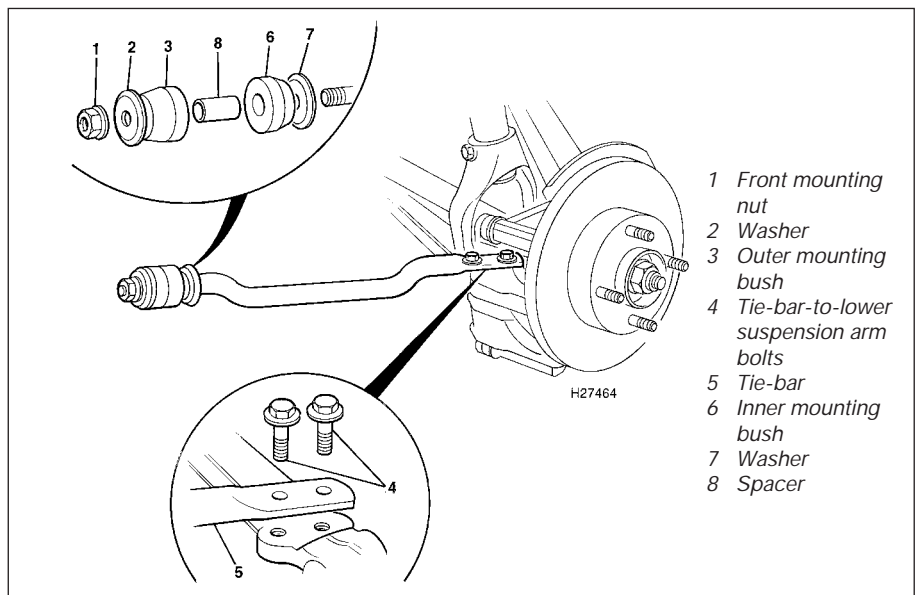

**10.3 Front tie-bar attachment details**



4 Undo the two bolts securing the tie-bar to the lower suspension arm, and remove the bar from under the car.

5 Withdraw the spacer, inner mounting bush and washer.

6 Renew the mounting bushes if they show any sign of deformation or swelling of the rubber.

**Refitting**

7 Fit the washer, inner bush and spacer, then locate the tie-bar in position.

8 Secure the tie-bar to the lower suspension arm, with the two bolts tightened to the specified torque.

9 Fit the outer bush and washer, followed by the retaining nut, but do not tighten the nut fully until the weight of the car is on its roadwheels.

10 Refit the roadwheel, then lower the car to the ground.

11 Tighten the roadwheel nuts and the tie-bar front mounting nut to the specified torque then refit the wheel trim.

12 Refit the undertray.



11.6a Undo the two screws (arrowed) . . .



11.6b . . . and remove the brake disc

2 Refer to Chapter 9 if necessary, and undo the two bolts securing the brake caliper carrier bracket to the hub carrier.

3 Undo the retaining bolt and release the flexible brake hose support bracket from the shock absorber strut.

4 Withdraw the carrier bracket, complete with caliper and brake pads, from the disc and hub carrier. Tie the caliper assembly from a convenient place under the wheelarch to avoid straining the brake hose.

5 On cars equipped with ABS, withdraw the rear wheel speed sensor and wiring harness from the hub carrier, as described in Chapter 9.

6 Undo the two screws and remove the brake disc from the hub flange (see illustrations).

7 Undo the nut and release the anti-roll bar connecting link from the suspension lower transverse link (see illustration).

8 Place a jack beneath the transverse link, and raise the link slightly.

9 Undo the nut and remove the through-bolt and washers securing the hub carrier to the trailing link.

10 Undo the nut and remove the bolt securing the hub carrier to the transverse link.

11 Undo the nut and clamp bolt securing the shock absorber strut to the hub carrier.

12 Lower the jack slightly, and release the hub carrier from the shock absorber strut. If the strut is tight, spread the slot in the hub carrier with a screwdriver, and tap the carrier down with a copper or plastic mallet.

13 Withdraw the hub carrier from the transverse and trailing links, and remove it from the car.

**Refitting**

14 Refitting is a reversal of removal. Tighten all nuts and bolts to the specified torque, but do not fully tighten the transverse and trailing link retaining nuts until the weight of the car is on the roadwheels.

**11 Rear hub carrier - removal and refitting**



**Removal**

1 Chock the front wheels, prise off the rear wheel trim and slacken the wheel nuts. Jack up the rear of the car and support it on axle stands. Remove the rear roadwheel and release the handbrake.

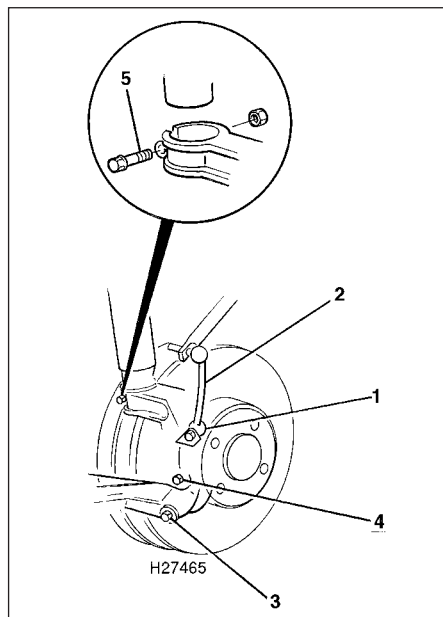

11.7 Rear hub carrier attachment details

- 1 Anti-roll bar connecting link nut
- 2 Anti-roll bar connecting link
- 3 Hub carrier-to-trailing link through bolt
- 4 Hub carrier-to-transverse link retaining bolt
- 5 Shock absorber clamp bolt

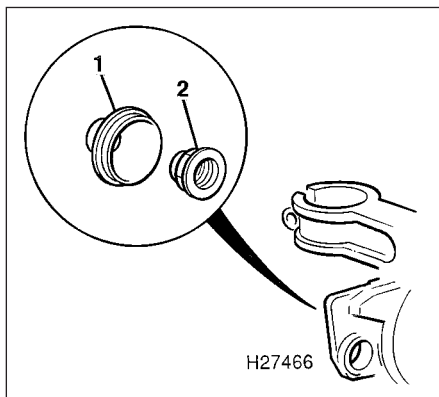

12.2 Cover (1) and hub flange retaining nut (2) at the rear of the hub carrier

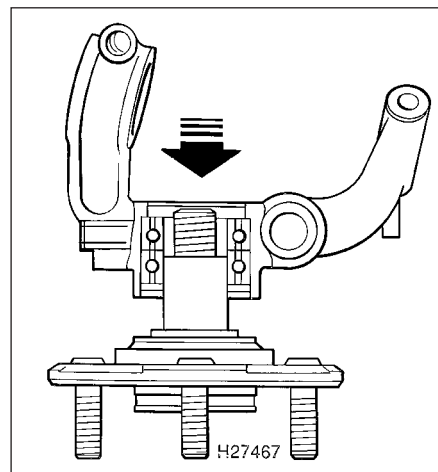

12.4 Removing the hub flange from the bearing

**12 Rear hub bearing - renewal**



**Note:** A new hub flange retaining nut will be required for reassembly.

1 Remove the rear hub from the car as described in the previous Section.

2 Prise off the cover over the hub flange retaining nut at the rear of the hub carrier, then secure the hub flange in a vice (see illustration).

3 Using a small punch or screwdriver, tap up the staking, then unscrew the hub flange retaining nut.

4 Support the hub carrier in a vice, and tap the hub flange out of the bearing (see illustration).

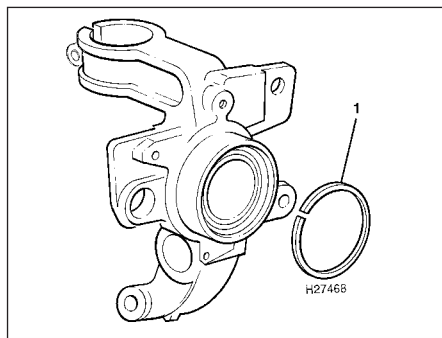

12.6a Extract the rear hub bearing retaining circlip (1) . . .

5 Undo the four screws and remove the disc shield.

6 Extract the bearing retaining circlip, then support the hub carrier face-down on blocks or on a press bed. Using a tube or mandrel in contact with the edge of the outer bearing, drive or press the bearing out (see illustrations).

7 Fit the new bearing in the same way, ensuring that it is pressed fully home to the shoulder in the hub carrier. Keep the bearing square as it is fitted, otherwise it will jam, and continued pressure could cause the outer race to crack. If the bearing does jam, tap or press it out, remove any burrs in the bore of the carrier and try again.

8 Secure the bearing with the circlip, then refit the disc shield.

9 Tap the hub flange into the bearing and fit a

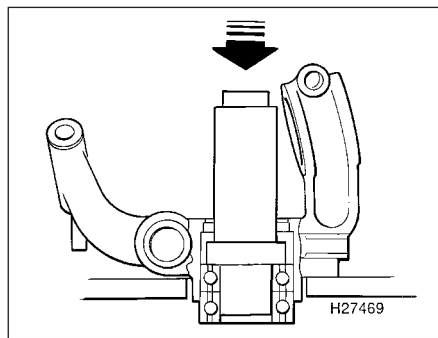

12.6b . . . then remove the bearing from the hub using a mandrel

new retaining nut. Tighten the nut to the specified torque, and secure by staking the nut flange into the groove in the hub. Tap on the nut cover.

10 Refit the hub carrier to the car as described in the previous Section.

### 13 Rear shock absorber - removal and refitting



**Note:** The following procedures are applicable equally to cars with standard suspension or self-levelling damper units.

#### Removal

1 Chock the front wheels, prise off the rear wheel trim and slacken the wheel nuts. Jack

up the rear of the car and support it on axle stands. Remove the rear roadwheel.

2 Undo the retaining bolt and release the flexible brake hose support bracket from the shock absorber strut.

3 Undo the nut and release the anti-roll bar connecting link from the suspension lower transverse link (see illustration).

4 Place a jack below the transverse link, and raise the link slightly.

5 Undo the nut and remove the through-bolt and washers securing the hub carrier to the trailing link.

6 Undo the nut and remove the bolt securing the hub carrier to the transverse link.

7 Undo the nut and clamp bolt securing the shock absorber strut to the hub carrier.

8 Lower the jack slightly, and release the hub carrier from the shock absorber strut. If the strut is tight, spread the slot in the hub carrier with a screwdriver, and tap the carrier down with a copper or plastic mallet.

9 From inside the luggage compartment, remove the trim as necessary to gain access to the shock absorber upper mounting.

10 Undo the three nuts securing the upper mounting to the body, and remove the shock absorber from under the wheelarch.

11 If the upper mounting is to be removed, undo the shock absorber spindle nut and withdraw the upper mounting, followed by the bump-stop and dust cover.

12 Examine the shock absorber for signs of fluid leakage. Check the spindle for signs of wear or pitting along its entire length, and check the shock absorber body for signs of damage or corrosion. Test the operation of the shock absorber, while holding it in an upright position, by moving the spindle through a full stroke, and then through short strokes of 50 to 100 mm. In both cases, the resistance felt should be smooth and continuous. If the resistance is jerky or uneven, or if there is any visible sign of wear, damage or fluid leakage, renewal is necessary. Also check the condition of the upper mounting, bump-stop and dust cover, and renew any components as necessary.

#### Refitting

13 Refitting is a reversal of removal. Tighten all nuts and bolts to the specified torque, but do not fully tighten the transverse and trailing link retaining nuts until the weight of the car is on the roadwheels.

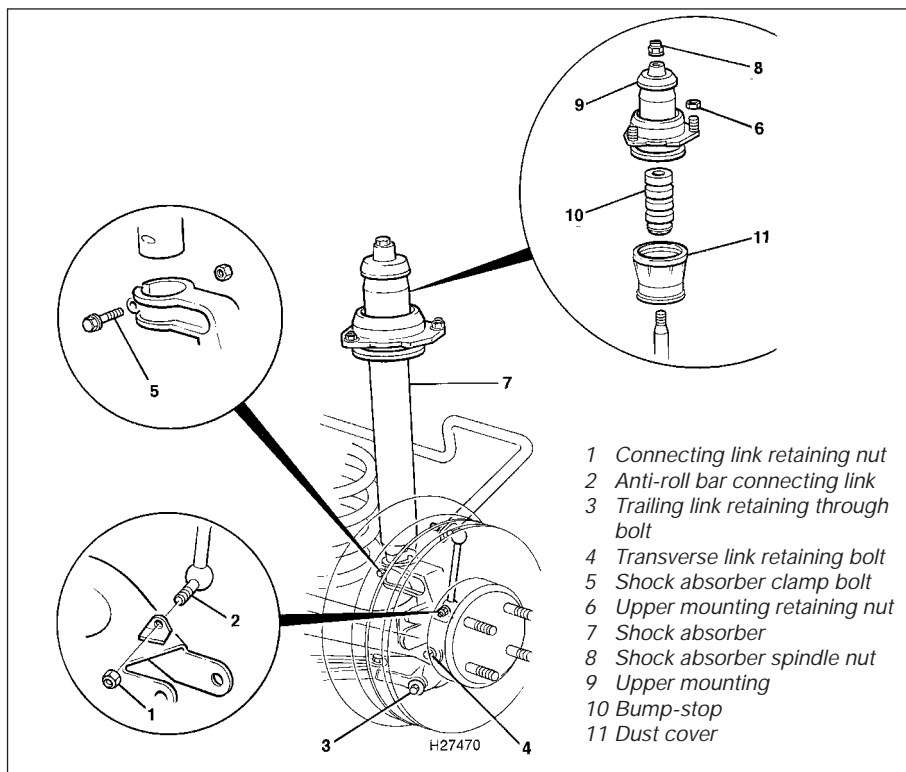

13.3 Rear shock absorber attachment details

### 14 Rear coil spring - removal and refitting



#### Removal

1 Refer to Section 13 and carry out the operations described in paragraphs 1 to 6 inclusive, with the exception of paragraph 2.

2 Ease the hub carrier away from the trailing link, and move the trailing link end clear as much as possible.

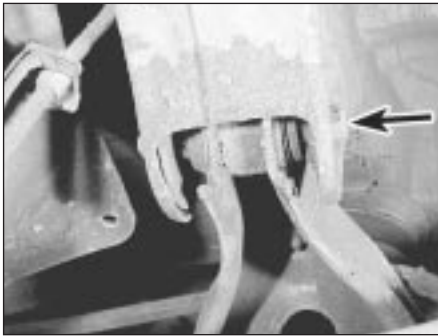

15.2 Transverse link inner mounting bolt (arrowed)

3 Lower the jack slowly and carefully to release the tension on the coil spring.

4 When all the tension is released, withdraw the spring from its location, and recover the upper and lower spring seats. Note the fitted position of the lower seat in the transverse link as it is removed.

5 Examine the spring carefully for signs of distortion or damage. The spring free length can only be assessed by comparing it with a new item, and this should be done if the spring is suspect. Renew the spring if necessary, ideally in pairs (both sides). Also check the condition of the upper and lower spring seats, and renew any components as necessary.

### Refitting

6 Refitting is a reversal of removal, but ensure that the tang on the lower spring seat engages with the slot in the transverse link. Tighten all nuts and bolts to the specified torque, but do not fully tighten the transverse and trailing link retaining nuts until the weight of the car is on the roadwheels.

### 15 Transverse link - removal and refitting



### Removal

1 Remove the rear coil spring as described in the previous Section.

2 Undo the nut and remove the transverse link inner mounting bolt (see illustration).

3 Ease the link away from its inner location, and remove it from under the car.

4 If the transverse link inner mounting bush requires renewal, a hydraulic press and mandrels will be needed to replace the bush. If this equipment is not available, have the work carried out by a Rover dealer or suitably-equipped garage. A similar procedure must be used for renewal of the outer bush, which is located in the hub carrier, after removal of this component from the car (see Section 11).

### Refitting

5 Refitting is a reversal of removal, but do not

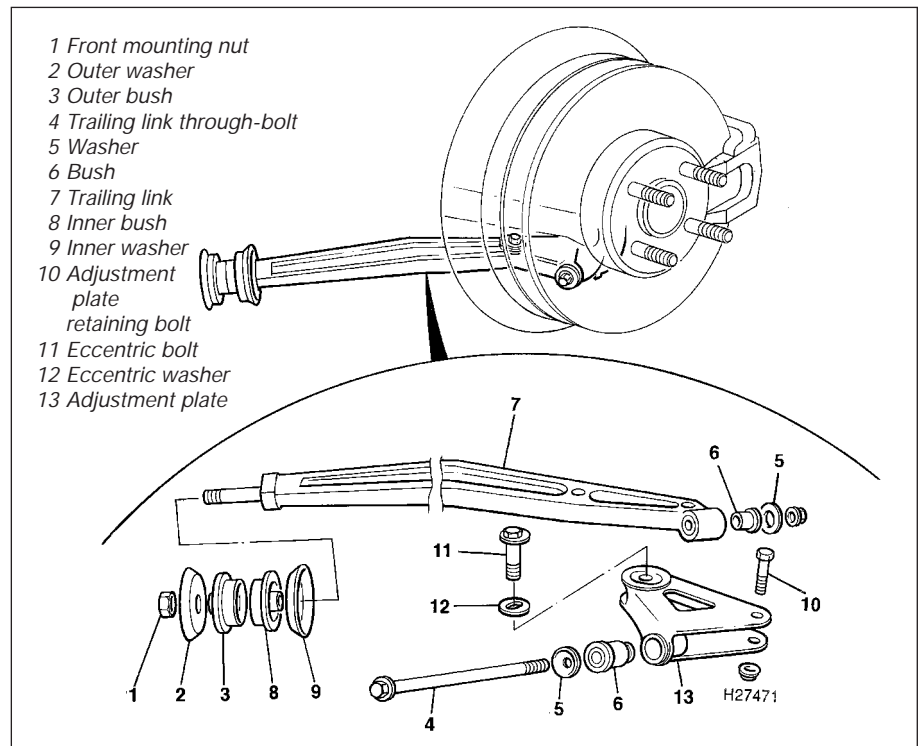

16.2 Trailing link components and attachments

fully tighten the inner mounting nut until the weight of the car is on the roadwheels.

### 16 Trailing link - removal and refitting



### Removal

1 Chock the front wheels, prise off the rear wheel trim and slacken the wheel nuts. Jack up the rear of the car and support it on axle stands. Remove the rear roadwheel.

2 Undo the trailing link front mounting nut and remove the outer washer and bush (see illustration).

3 Undo the nut and remove the through-bolt and washers securing the trailing link to the hub carrier.

4 Ease the link away from the hub carrier, withdraw the front mounting from its location and remove the link from under the car.

5 Withdraw the front mounting inner bush and washer, and the two rear mounting bushes.

6 If the adjustment plate is to be removed, first mark the position of the forward eccentric bolt in relation to the plate, so that an approximate rear wheel toe setting can be obtained on reassembly. Undo the nuts, remove the retaining bolt and eccentric bolt, then withdraw the adjustment plate from the trailing link.

7 Examine all the mounting bushes for

damage, deformation or swelling of the rubber, and check the remaining components for damage or distortion. Renew any parts as necessary.

### Refitting

8 Refit the adjustment plate to the link, and secure with the retaining and adjustment bolts and nuts. Before fully tightening the nuts, set the eccentric adjustment bolt in the position marked before removal.

9 The remainder of the refitting procedure is a reversal of removal. Do not fully tighten the trailing link-to-hub carrier through-bolt until the weight of the car is on the roadwheels.

10 On completion, have the rear wheel alignment checked and if necessary adjusted (see Section 28).

### 17 Rear anti-roll bar - removal and refitting



### Removal

1 Apply the handbrake, prise off the rear wheel trims and slacken the wheel nuts. Jack up the rear of the car and support it on axle stands. Remove the rear roadwheels.

2 Undo the single nut each side securing the anti-roll bar connecting links to the rear suspension transverse links.

3 Undo the two bolts each side securing the anti-roll bar mounting brackets to the chassis

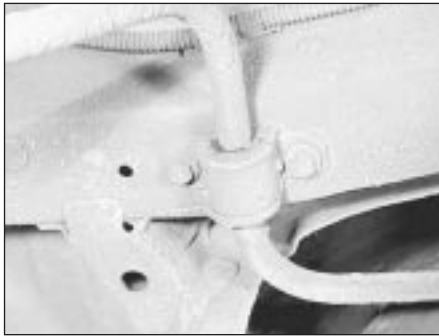

17.3 Anti-roll bar right-hand side mounting bracket

members, and remove the bar from under the car (see illustration).

4 If required, the connecting links can be removed after undoing the retaining nut on each side.

5 Check the condition of the connecting link bushes and the anti-roll bar mounting bushes, and renew any that show signs of deterioration. The mounting bushes are slit along their length to allow removal and refitting over the bar.

### Refitting

6 Refitting is a reversal of removal. Tighten the mounting and connecting link bushes to the specified torque only with the weight of the car on its roadwheels.

## 18 Steering wheel - removal and refitting



### Models without airbag supplementary restraint system

#### Removal

1 Disconnect the battery negative (earth) lead (refer to Chapter 5, Section 1).

2 Set the front wheels in the straight-ahead position.

3 On early models, carefully prise off the



18.3a Prise off the steering wheel pad . . .

steering wheel pad, disconnect the two horn switch leads and remove the pad (see illustrations).

4 On later models, undo the two screws at the rear of the steering wheel and lift off the steering wheel pad.

5 On models equipped with cruise control, disconnect the cruise control switch multiplug from the rotary coupler wiring harness.

6 With an assistant holding the wheel, undo and remove the centre retaining nut using a socket and bar (see illustration).

7 Mark the steering wheel and column shaft in relation to each other, and withdraw the wheel from the shaft splines.

#### Refitting

8 Before refitting, check that the wheels are still in the straight-ahead position and, where applicable, turn the direction indicator cancelling bush so that the slot is pointing upwards (see illustration).

9 Engage the steering wheel over the shaft splines, ensuring that the previously-made marks are aligned, and make sure that the lug on the wheel boss engages with the slot in the direction indicator cancelling bush (see illustration).

10 On models equipped with cruise control, ensure that the rotary coupler lugs engage with the steering wheel slots.

11 Refit the retaining nut and tighten it to the specified torque while your assistant holds the wheel.



18.3b . . . and disconnect the two horn switch leads

12 Reconnect the horn switch wires (early models) and refit the steering wheel pad.

13 Reconnect the battery.

### Models with airbag supplementary restraint system



**Warning:** Handle the airbag unit with extreme care as a precaution against personal injury, and always hold it with the cover facing away from the body. If in doubt concerning any proposed work involving the airbag unit or its control circuitry, consult a Rover dealer or other qualified specialist.

#### Removal

14 Disconnect the battery negative (earth) lead first, followed by the positive lead (refer to Chapter 5, Section 1).



**Warning:** Before proceeding, wait a minimum of 20 minutes, as a precaution against accidental firing of the airbag unit. This period ensures that any stored energy in the back-up capacitor is dissipated.

15 Release the four turnbuckles and lift off the fusebox cover below the steering column.

16 Disconnect the airbag wiring multiplug from the steering column wiring harness at the base of the column.

17 Using a Torx type socket bit, unscrew the



18.6 Undo the steering wheel retaining nut



18.8 Position the direction indicator cancelling bush with the slot pointing upwards

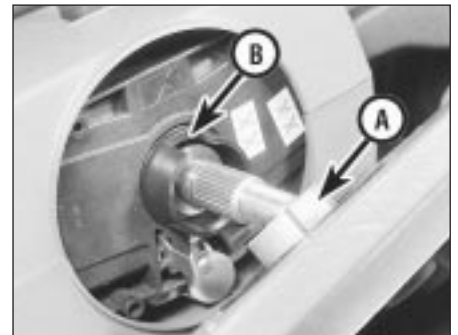

18.9 Ensure that the lug on the steering wheel boss (A) engages the cancelling bush slots (B)



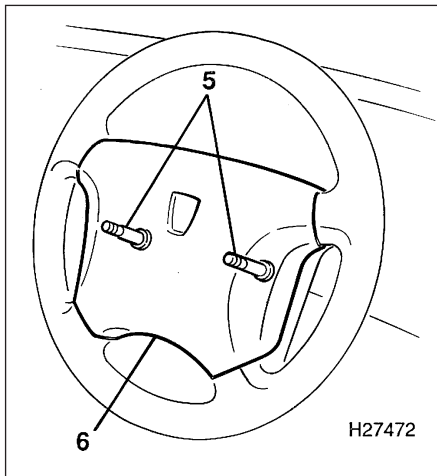

**18.17** Unscrew the two retaining screws (5) securing the airbag (6) to the steering wheel

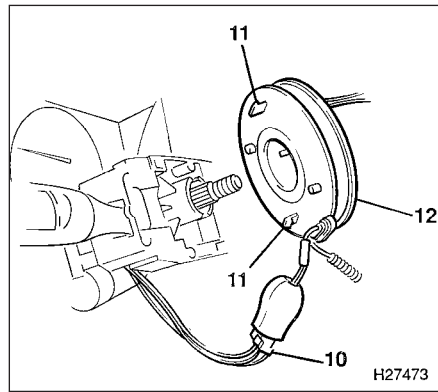

**19.6** Rotary coupler connections on models with airbag supplementary restraint system and/or cruise control

- 10 Rotary coupler multiplug
- 11 Plastic retaining clips
- 12 Rotary coupler

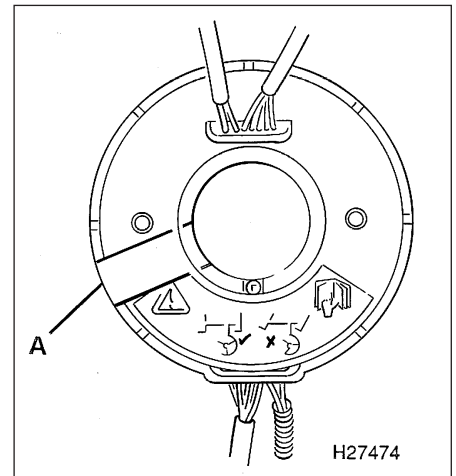

**19.7** After removal, secure the two halves of the rotary coupler to prevent rotation, using adhesive tape applied to position (A)

two airbag module retaining screws from the rear of the steering wheel (see illustration).  
**18** Lift the airbag module off the steering wheel, disconnect the multiplug from the rear of the module and remove the module from the vehicle.



**Warning:** Position the airbag unit in a safe place, with the mechanism facing downwards as a precaution against accidental operation.



**Warning:** Do not attempt to open or repair the airbag unit, or apply any electrical current to it. Do not use any airbag which is

visibly damaged or which has been tampered with.

**19** Set the front wheels in the straight-ahead position.

**20** On models equipped with cruise control, disconnect the cruise control switch multiplug from the rotary coupler wiring harness and release the harness from the steering wheel clip.

**21** With an assistant holding the wheel, undo and remove the centre retaining nut using a socket and bar.

**22** Mark the steering wheel and column shaft in relation to each other, and withdraw the wheel from the shaft splines.

**23** On models with cruise control, feed the wiring harness through the hole in the steering wheel as it is withdrawn.

### Refitting

**24** Check that the front wheels are still in the straight-ahead position, then engage the steering wheel over the shaft splines, while at the same time feeding the wiring harness through the hole in the wheel. Ensure that the previously-made marks are aligned, and that the rotary coupler lugs engage with the steering wheel slots.

**25** Refit the retaining nut and tighten it to the

specified torque while your assistant holds the wheel.

**27** Reconnect the cruise control wiring (where applicable).

**28** Reconnect the wiring multiplug to the rear of the airbag module with the harness pointing downward.

**29** Locate the airbag module on the steering wheel and secure with the two retaining screws.

**30** Reconnect the airbag wiring multiplug to the steering column wiring harness and refit the fusebox cover.

**31** Reconnect the battery.

## 19 Rotary coupler - removal and refitting



### Removal

**1** A rotary coupler is fitted between the steering wheel and steering column multifunction switch on vehicles equipped with an airbag supplementary restraint system and/or cruise control.

**2** Remove the steering wheel as described in Section 18.

**3** From inside the car, release the turnbuckles and lift out the trim panels over the clutch, brake and accelerator pedals.

**4** Release the rake lock on the side of the steering column, and move the column to its lowest position.

**5** Undo the single upper screw and the three lower screws, and remove the upper and lower steering column shrouds.

**6** Disconnect the rotary coupler multiplug from the steering column wiring harness (see illustration). On models equipped with an airbag, release the airbag wiring harness connector from the steering column bracket

and remove the harness cable ties from the column.

**7** Ensure that the front roadwheels are in the straight-ahead position then release the two plastic clips and withdraw the coupler from the steering column multifunction switch.

**Note:** The rotary coupler must not be turned whilst it is removed. To prevent rotation of the two coupler halves, place a piece of adhesive tape around the moulding as shown (see illustration). Store the coupler in a plastic bag after removal as an added precaution against rotation or damage.

### Refitting

**8** Refitting is a reversal of removal bearing in mind the following points:

- (a) If a new rotary coupler is being fitted it will be supplied with sealing tape around the moulding to prevent rotation of the coupler halves. Do not use the coupler if the sealing tape is broken.
- (b) If the original rotary coupler is being refitted, remove the previously applied adhesive tape before positioning the unit on the steering column.
- (c) Use new cable ties to secure the wiring harness to the steering column.
- (d) Refit the steering wheel as described in Section 18.

## 20 Steering column lock - removal and refitting



### Removal

**1** Remove the steering wheel as described in Section 18.

**2** From inside the car, release the turnbuckles and lift out the trim panels over the clutch, brake and accelerator pedals.

**3** Release the rake lock on the side of the

## 21 Steering column - removal and refitting



### Removal

- 1 Disconnect the battery negative (earth) lead (refer to Chapter 5, Section 1).
- 2 Remove the steering wheel and, where fitted, the rotary coupler as described in Sections 18 and 19 respectively.
- 3 From inside the car, release the turnbuckles and lift out the trim panels over the clutch, brake and accelerator pedals (see illustrations).
- 4 Release the rake lock on the side of the steering column, and move the column to its lowest position.
- 5 Undo the single upper screw and the three lower screws, and remove the upper and lower steering column shrouds.
- 6 At the base of the steering column, release the two retaining clips and slide the cover up over the column shaft universal joint (see illustration).
- 7 Move the carpets aside to gain access to the floor-mounted cover plate.
- 8 Prise out the retaining studs to release the cover plate and gasket from the floor.
- 9 Undo the clamp bolt securing the universal joint to the steering gear pinion.
- 10 Undo the two nuts and remove the washers from the steering column upper mounting (see illustration).
- 11 Undo the two bolts and remove the mounting strap from the column lower mounting (see illustration). Lower the column slightly, and support it in this position.
- 12 Release the flasher unit from its bracket above the fusebox.
- 13 Disconnect the two ignition switch wiring multiplugs from the fusebox and, where applicable, the additional multiplugs at the base of the column. Release the multiplugs and wiring from the column brackets as necessary.
- 14 Lift the column assembly upwards to disengage the universal joint from the steering gear pinion, then remove the column from the car.
- 15 If the universal joint is to be removed, mark the joint in relation to the column shaft. Undo the clamp bolt and slide the joint off the shaft.

### Refitting

- 16 Before refitting the column, set the roadwheels to the straight-ahead position.
- 17 Refit the universal joint to the column shaft (if previously removed), ensuring that the marks made during removal are aligned.
- 18 Engage the universal joint with the steering gear pinion, and push it fully home.
- 19 Reconnect the wiring multiplugs and refit the flasher unit.

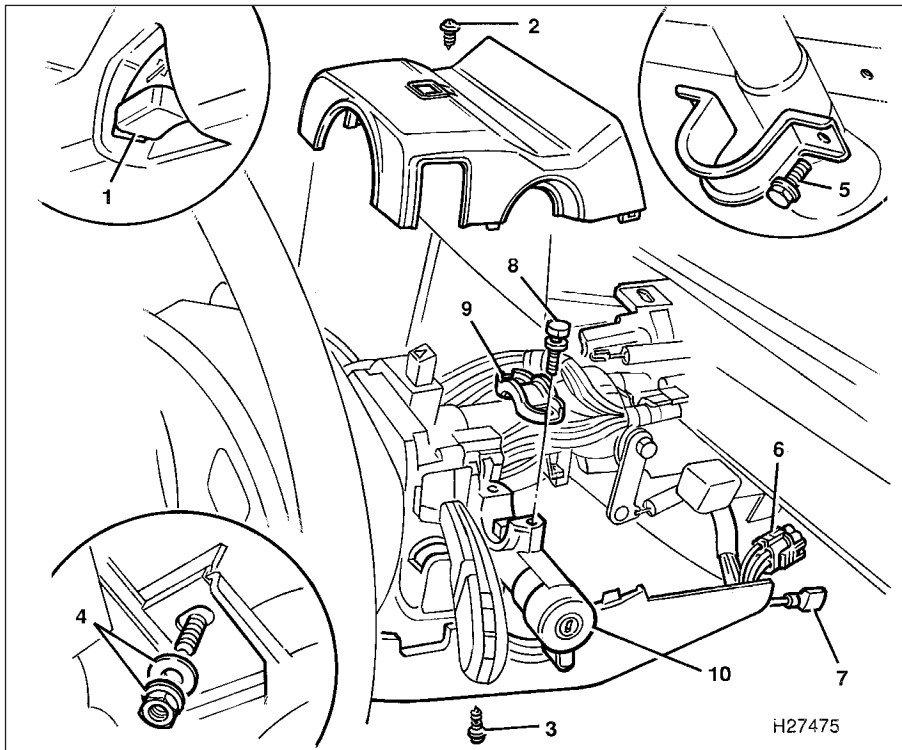

### 20.3 Steering column lock attachments

- |  |                                    |
|--|------------------------------------|
| 1 Steering column rake lock            | 6 Ignition switch wiring multiplug |
| 2 Upper shroud retaining screw         | 7 Additional switch lead           |
| 3 Lower shroud retaining screws        | 8 Shear bolt                       |
| 4 Column upper mounting nut and washer | 9 Lock saddle                      |
| 5 Column lower mounting bolts          | 10 Steering column lock            |

steering column, and move the column to its lowest position (see illustration).

4 Undo the single upper screw and the three lower screws, and remove the upper and lower steering column shrouds.

5 Undo the two nuts and remove the washers from the steering column upper mounting.

6 Undo the two bolts and remove the mounting strap from the column lower mounting. Lower the column slightly, and support it in this position.

7 Disconnect the two ignition switch wiring multiplugs from the fusebox.

8 Centre-punch the steering column lock

shear-bolts, then drill off the bolt heads.

9 Remove the lock saddle, then withdraw the lock from the column.

10 With the lock removed, unscrew the shear-bolt studs with a self-locking wrench or a pair of grips on the protruding bolt ends.

### Refitting

11 Refitting is a reversal of removal, but tighten all the mounting bolts and nuts to the specified torque. Use new shear-bolts to secure the lock, and tighten them until the heads shear off, but check the operation of the lock before doing this.



21.3a Remove the upper trim panel . . .



21.3b . . . and lower trim panel over the pedals

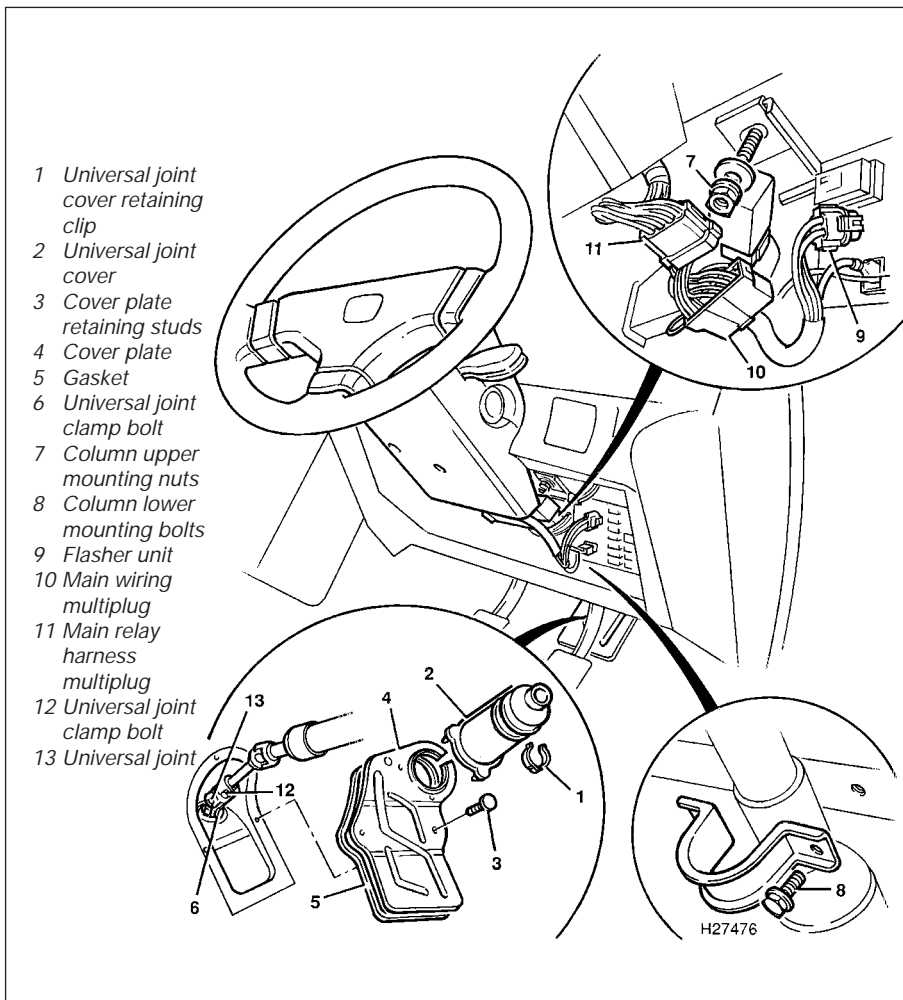

21.6 Steering column attachments and components

- 20 Refit the column mountings, and tighten the nuts and bolts to the specified torque.
- 21 Tighten the universal joint clamp bolt.
- 22 Refit the cover plate and gasket, followed by the universal joint cover.
- 23 Refit the steering column shrouds and the trim panels.
- 24 Refit the rotary coupler (where applicable) and steering wheel as described in Sections 19 and 18, then reconnect the battery.

## 22 Steering track rod - removal and refitting

### Removal

- 1 Apply the handbrake, remove the front wheel trim and slacken the wheel nuts. Jack up the front of the car and support it on axle



22.2 Steering track rod retaining locknut (arrowed)



22.3 Extract the split pin and remove the track rod retaining nut (arrowed)



22.4 Using a universal balljoint separator tool to release the track rod balljoint



21.10 Steering column upper mounting nut (arrowed)



21.11 Steering column lower mounting bolt (arrowed)

- stands. Remove the front roadwheel.
- 2 Slacken the track rod retaining locknut by a quarter of a turn (see illustration).
- 3 Extract the split pin, then unscrew the nut securing the track rod balljoint to the steering knuckle arm (see illustration).
- 4 Using a universal balljoint separator tool, release the tapered ball-pin from the arm (see illustration).
- 5 Engage a spanner over the flats on the inner track rod that protrudes from the rubber gaiter, then unscrew the steering track rod and outer balljoint assembly.

### Refitting

- 6 Fit the new track rod by screwing it on to the inner track rod until it contacts the locknut.





24.10 Unscrew the two fluid pipe union nuts (arrowed)

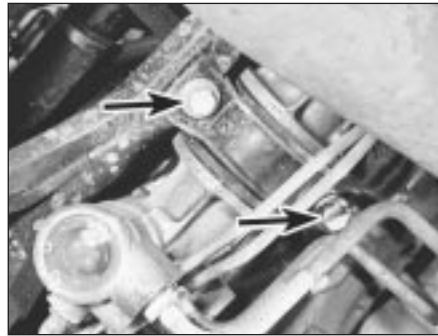

24.12a Steering gear right-hand mounting bracket bolts (arrowed) . . .



24.12b . . . and left-hand mounting bracket bolts (arrowed)

7 Insert the balljoint into the steering knuckle arm and refit the retaining nut. Tighten the nut to the specified torque, then tighten it further, slightly, to align the next split pin hole. Secure the nut with a new split pin.

8 Tighten the track rod retaining locknut securely, refit the roadwheel and lower the car to the ground. Tighten the wheel nuts and refit the wheel trim.

9 Check the front wheel alignment as described in Section 28.

### 23 Steering gear rubber gaiter - renewal



#### Removal

1 Remove the steering track rod as described in the previous Section.

2 Count and record the number of exposed threads from the end of the inner track rod to the locknut, then unscrew and remove the locknut.

3 Release the rubber gaiter retaining clips, remove the transfer tube (V6 engine models) and withdraw the gaiter from the steering gear and inner track rod.

#### Refitting

4 Slide the new gaiter into position and secure it with new retaining clips. Where applicable, refit the transfer tube.

5 Refit the locknut to the inner track rod, and position it so that the same number of threads are exposed as counted on removal.

6 Refit the steering track rod as described in the previous Section.

### 24 Steering gear - removal and refitting



#### 4-cylinder engine models

##### Removal

1 From inside the car, release the two retaining clips and slide up the cover over the universal joint at the base of the steering column (see illustration 21.6).

2 Move the carpets aside to gain access to the floor-mounted cover plate.

3 Prise out the retaining studs to release the cover plate and gasket from the floor.

4 Undo the clamp bolt securing the universal joint to the steering gear pinion.

5 Apply the handbrake, remove the front wheel trims and slacken the wheel nuts. Jack up the front of the car and support it on axle stands. Remove the front roadwheels.

6 Remove the exhaust front pipes as described in the relevant Part of Chapter 4.

7 Extract the split pins, then unscrew the nuts securing each track rod balljoint to the steering knuckle arm.

8 Using a universal balljoint separator tool, release the balljoint tapered ball-pins from the arms.

9 Position a suitable container beneath the pinion end of the steering gear.

10 Wipe clean the area around the fluid pipe unions, then unscrew the two rearward-facing union nuts on the pinion housing (see illustration). Allow the power steering fluid to drain into the container.

11 Remove the two O-ring seals from the disconnected pipes, then plug or tape over the pipe ends and orifices.

12 Undo the two bolts each side securing the steering gear to the chassis members, and remove the mounting brackets (see illustrations).

13 Lower the steering gear to release the pinion from the column universal joint, then manipulate the assembly sideways and out through the wheelarch.

14 Check the condition of the rubber mountings, and renew them if there is any sign of deterioration or swelling of the rubber.

##### Refitting

15 Refitting the steering gear is a reversal of removal, bearing in mind the following points:

- Tighten all nuts, bolts and unions to the specified torque.
- Use new O-ring seals on the pipe unions, and new split pins on the balljoint retaining nuts.
- Fill the system with fresh fluid, and bleed the steering gear as described in Section 25.
- If necessary, reposition the steering wheel

so that the spokes are horizontal when the steering gear is in the straight-ahead position (see Section 18).

#### V6 engine models

##### Removal

16 Proceed as described in paragraphs 1 to 8 above.

17 Undo the bolts securing the longitudinal support member to the underbody beneath the engine and remove the member.

18 Engage a spanner over the flats on the left-hand inner track rod that protrudes from the rubber gaiter, then unscrew the steering track rod and outer balljoint assembly. Remove the right-hand steering track rod in the same way.

19 Undo the four bolts and remove the cover plate from below the pinion end of the steering gear.

20 Position a suitable container beneath the steering gear fluid pipes.

21 Wipe clean the area around the fluid pipe unions, then unscrew the four union nuts on the pinion housing. Allow the power steering fluid to drain into the container.

22 Plug or tape over the disconnected pipe ends and orifices to prevent dirt entry.

23 Undo the two bolts each side securing the steering gear to the chassis members, and remove the mounting brackets.

24 Lower the steering gear to release the pinion from the column universal joint, then manipulate the assembly sideways and out through the wheelarch.

25 Check the condition of the rubber mountings, and renew them if there is any sign of deterioration or swelling of the rubber.

##### Refitting

26 Refitting the steering gear is a reversal of removal, bearing in mind the following points:

- Tighten all nuts, bolts and unions to the specified torque.
- Use new split pins on the balljoint retaining nuts.
- Fill the system with fresh fluid, and bleed the steering gear as described in Section 25.
- If necessary, reposition the steering wheel so that the spokes are horizontal when the steering gear is in the straight-ahead position (see Section 18).





26.7 Slacken the tensioner wheel retaining nut



26.8 Unscrew the pump pulley retaining nut



26.9 Withdraw the pulley and drivebelt from the pump

## 25 Power steering gear - bleeding



- 1 Remove the filler cap on the power steering fluid reservoir, and fill the reservoir with the specified fluid until the level is up to the MAX mark on the cap dipstick.
- 2 Disconnect the HT lead from the centre of the ignition coil.
- 3 Crank the engine on the starter motor for five seconds to prime the power steering pump.
- 4 Top up the reservoir, then crank the engine again for a further five seconds.
- 5 Turn the steering onto full right-hand lock, and crank the engine for five seconds.
- 6 Turn the steering onto full left-hand lock, top up the reservoir, and reconnect the HT lead to the coil.
- 7 Start the engine and run it for approximately two minutes. During this time, turn the steering wheel one turn each way.
- 8 With the engine stopped, check the condition of the power steering fluid. If it is aerated, leave it until clear. Once the fluid is clear, top up the reservoir, start the engine again and run it for a further two minutes. During this time, turn the steering wheel one turn each way as before.

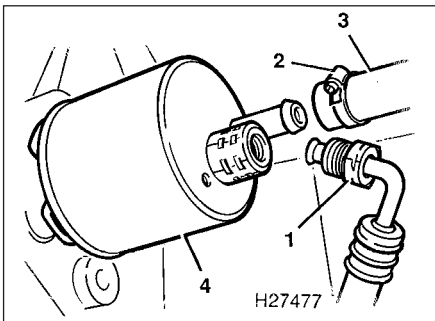

26.14 Fluid pipe connections at the rear-mounted power steering pump

- 1 High pressure pipe union
- 2 Return hose clip
- 3 Return hose
- 4 Power steering pump

## 26 Power steering pump - removal and refitting



### 4-cylinder engine models with rear-mounted, camshaft-driven pump

#### Removal

- 1 Disconnect the battery negative (earth) lead (refer to Chapter 5, Section 1).
- 2 Drain the cooling system as described in Chapter 1.
- 3 Refer to the relevant Part of Chapter 4 and remove the air cleaner assembly.
- 4 Slacken the hose clips and disconnect the heater bypass hose from the thermostat housing, and the radiator bottom hose from the main coolant pipe below the distributor.
- 5 Undo the bolts securing the heater pipe and coolant pipe to their support brackets, and move the pipe and hose assembly away from the vicinity of the power steering pump as far as possible.
- 6 Undo the retaining screw and remove the cover over the camshaft pulley.
- 7 Slacken the centre retaining nut on the drivebelt tensioner wheel, then turn the tension adjuster clockwise until the bolt is slack (see illustration).
- 8 Using a socket and bar, unscrew and



26.15 Undo the four pump retaining bolts

remove the power steering pump pulley retaining nut (see illustration). To prevent the pulley turning as the nut is undone, engage a large screwdriver with one of the slots on the pulley, rest the screwdriver over the socket, and apply clockwise leverage to the screwdriver.

- 9 Withdraw the pulley and drivebelt from the pump (see illustration). Use two screwdrivers to lever off the pulley if it is tight.
- 10 Apply the handbrake, jack up the front of the car and support it on axle stands.
- 11 Undo the bolts securing the longitudinal support member to the underbody beneath the engine and remove the member.
- 12 Position a suitable container beneath the engine, below the power steering pump.
- 13 Wipe clean the area around the pipe and hose unions at the rear of the pump.
- 14 Unscrew the union nut and slacken the hose clip, then disconnect the high pressure pipe and return hose from the pump (see illustration). Allow the power steering fluid to drain into the container. Plug or tape over the disconnected unions when the fluid has drained.
- 15 Undo the four power steering pump retaining bolts, and remove the pump from under the car (see illustration).

#### Refitting

- 16 Refitting is a reversal of removal, bearing in mind the following points:
  - (a) Tighten all nuts, bolts and unions to the specified torque.
  - (b) Refit and tension the drivebelt as described in Chapter 1.
  - (c) Bleed the power steering gear as described in Section 25.
  - (d) Refill the cooling system and refit the air cleaner as described in Chapters 1 and 4 respectively.

### 4-cylinder engine models with front-mounted, crankshaft-driven pump

#### Removal

- 17 Remove the auxiliary drivebelt as described in Chapter 1.
- 18 On later models, refer to Chapter 5 and remove the alternator if access to the pump mounting bolts is limited.

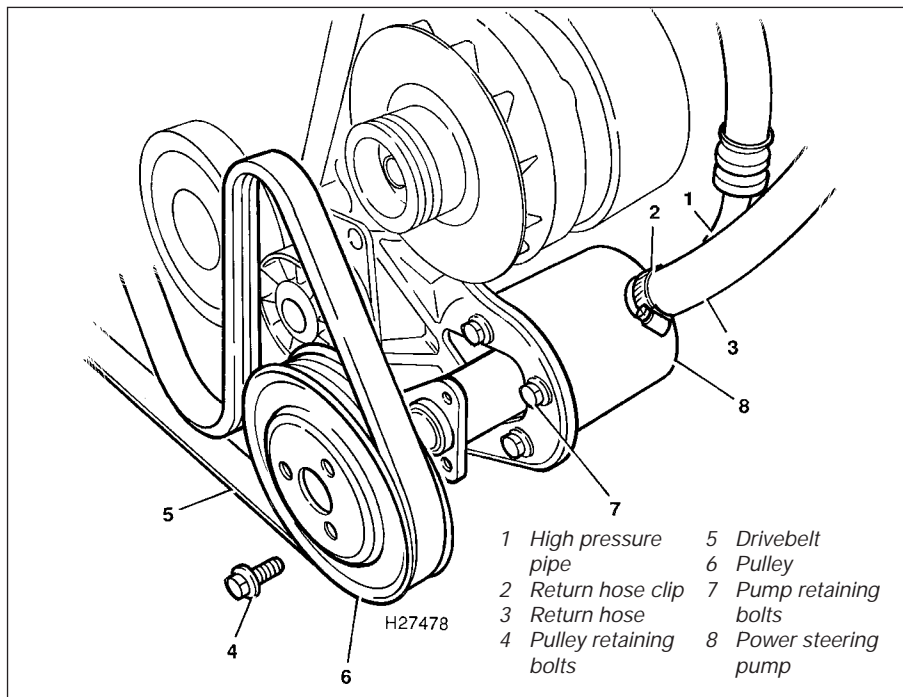

26.22 Power steering pump attachments on 4-cylinder engine models with front mounted pump (early version shown, later version similar)

- 19 On models with air conditioning, remove the heat shield (where fitted) from the rear of the pump.
- 20 Position a suitable container beneath the engine, below the power steering pump.



26.27b . . . release the pipes and cables from the support brackets . . .

- 21 Wipe clean the area around the pipe and hose unions at the rear of the pump.
- 22 Unscrew the union nut and slacken the hose clip, then disconnect the high pressure pipe and return hose from the pump (see illustration). Allow the power steering fluid to drain into the container. Plug or tape over the disconnected unions when the fluid has drained.
- 23 Undo the three bolts and remove the power steering pump pulley.
- 24 Undo the four bolts (early version) or five bolts (later version) securing the pump to its mounting bracket. Slide the pump out of the bracket, and remove it from under the car.

**Refitting**

- 25 Refitting is a reversal of removal, bearing in mind the following points:
  - (a) Tighten all nuts, bolts and unions to the specified torque.



26.27c . . . and cover clips . . .



26.27d . . . and lift off the two covers



26.27a Undo the three nuts/bolts (arrowed) securing the pulley covers to the top of the engine . . .

- (b) Refit and tension the drivebelt as described in Chapter 1.
- (c) Bleed the power steering gear as described in Section 25.

**V6 engine models**

**Removal**

- 26 Disconnect the battery negative (earth) lead (refer to Chapter 5, Section 1).
- 27 Undo the three bolts or nuts securing the power steering pump and alternator pulley covers to the top of the engine. Move the pipes and cables clear and lift off the covers (see illustrations).
- 28 Wipe clean the area around the pipe and hose unions on the top of the pump.
- 29 Place absorbent rags around the power steering pump and be prepared for fluid spillage.
- 30 Undo the two bolts securing the high pressure pipe connector, lift off the connector and recover the O-ring (see illustration).
- 31 Slacken the hose clip, then disconnect the return hose from the pump. Plug or tape over the disconnected unions to prevent dirt entry.
- 32 Slacken the pump adjusting nut and mounting bolt, push the pump down and slip the drivebelt off the pump pulley (see illustrations).
- 33 Remove the mounting bolt and adjusting nut and lift the pump off the engine.

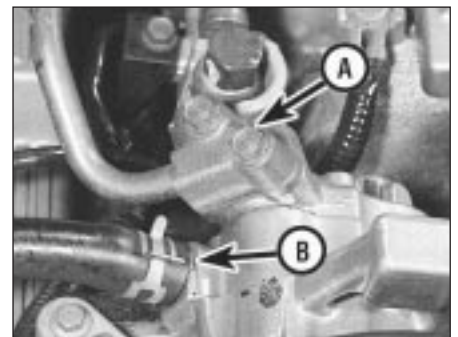

26.30 High pressure pipe connector (A) and return hose connection (B) at the power steering pump

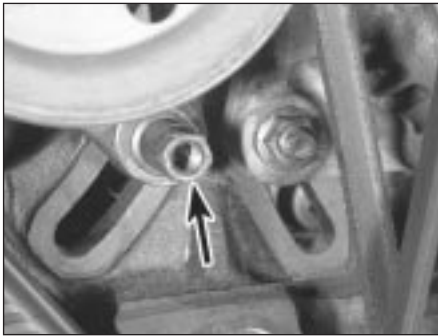

26.32a Power steering pump adjusting nut (arrowed) . . .

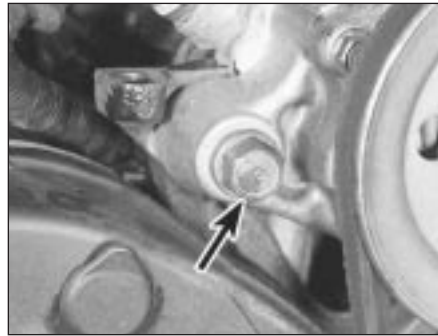

26.32b . . . and mounting bolt (arrowed)

**Refitting**

34 Refitting is a reversal of removal, bearing in mind the following points:

- (a) Tighten all nuts, bolts and unions to the specified torque.
- (b) Use a new O-ring on the high pressure pipe connector.
- (c) Refit and tension the drivebelt as described in Chapter 1.
- (c) Bleed the power steering gear as described in Section 25.

**27 Power steering fluid cooler - removal and refitting**

**4-cylinder engine models**

**Removal**

- 1 Disconnect the battery negative (earth) lead (refer to Chapter 5, Section 1).
- 2 Remove the front bumper as described in Chapter 11.
- 3 Position a suitable container beneath the engine, below the power steering fluid reservoir and place absorbent rags under the reservoir.
- 4 Slacken the hose clip and disconnect the fluid cooler hose at the reservoir. Plug the disconnected unions quickly to minimise fluid spillage.
- 5 Locate the remaining hose-to-pipe connectors and release the hose clips or disconnect the pipe connectors as applicable.
- 6 Undo the two fluid cooler retaining nuts and remove the cooler.

**Refitting**

7 Refitting is a reversal of removal. Bleed the power steering gear as described in Section 25 on completion.

**V6 engine models**

**Removal**

- 8 Disconnect the battery negative (earth) lead (refer to Chapter 5, Section 1).
- 9 Remove the side lights and the right-hand headlight as described in Chapter 12. On early

models, remove the radiator grille as described in Chapter 11.

- 10 Position a suitable container beneath the front of the car, below the fluid cooler unions.
- 11 Slacken the hose clips and disconnect the four fluid cooler hose connections, two at each end of the cooler. Plug the disconnected unions quickly to minimise fluid spillage.
- 12 Undo the two fluid cooler retaining nuts and remove the cooler.

**Refitting**

13 Refitting is a reversal of removal. Bleed the power steering gear as described in Section 25 on completion.

**28 Wheel alignment and steering angles - general information**

1 Accurate front wheel alignment is essential to provide positive steering and prevent excessive tyre wear. Before considering the steering/suspension geometry, check that the tyres are correctly inflated, that the front wheels are not buckled, and that the steering linkage and suspension joints are in good order, without slackness or wear.

2 Wheel alignment consists of four factors (see illustration):

*Camber* is the angle at which the front wheels are set from the vertical when viewed from the front of the vehicle. "Positive camber" is the amount (in degrees) that the wheels are tilted outward at the top from the vertical.

*Castor* is the angle between the steering axis and a vertical line when viewed from each side of the car. "Positive castor" is when the steering axis is inclined rearward at the top.

*Steering axis inclination* is the angle (when viewed from the front of the vehicle) between the vertical and an imaginary line drawn through the steering knuckle upper and lower balljoints.

*Toe setting* is the amount by which the distance between the front inside edges of the roadwheels (measured at hub height) differs from the diametrically opposite distance measured between the rear inside edges of the front roadwheels.

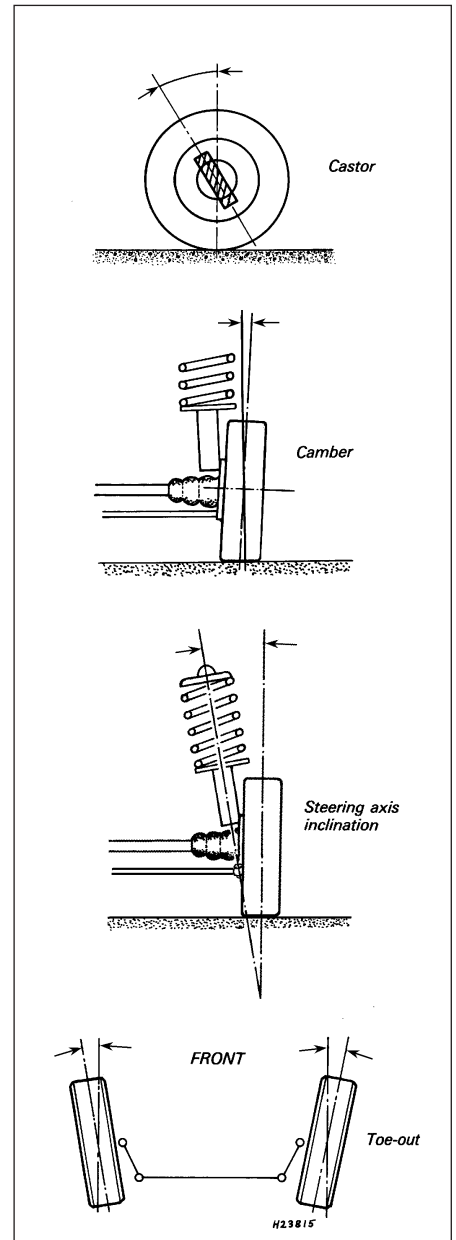

28.2 Wheel alignment and steering angle measurements

3 With the exception of the front and rear toe setting, all other suspension and steering angles are set during manufacture and no adjustment is possible. It can be assumed, therefore, that unless the vehicle has suffered accident damage all the preset angles will be correct. Should there be some doubt about their accuracy it will be necessary to seek the help of a Rover dealer, as special gauges are needed to accurately check the suspension and steering angles.

4 The front and rear toe settings are adjustable, and two methods are available to the home mechanic for doing this. One method is to use a gauge to measure the distance between the front and rear inside

edges of the roadwheels. The other method is to use a scuff plate, in which the roadwheel is rolled across a movable plate which records any deviation, or scuff, of the tyre relative to the straight-ahead position, as it moves across the plate. Relatively inexpensive equipment of both types is available from accessory outlets to enable these checks, and subsequent adjustments, to be carried out at home.

### Toe setting - checking and adjusting

#### Front wheel toe setting

**5** With the car on level ground and the steering in the straight-ahead position, bounce the front and rear to settle the suspension, then push the car backwards then forwards. Follow the equipment manufacturer's instructions according to the equipment being used, and check the toe setting.

**6** If adjustment is required, slacken the steering track rod locknuts on both sides, and release the rubber gaiter retaining clips (see illustration).

**7** Using a spanner engaged with the flat on the inner track rod, turn both track rods, by equal amounts clockwise to increase the toe-in, or anti-clockwise to increase the toe-out. Push the car forwards, then recheck the setting. If a gauge is being used, take three readings, at 120° intervals around the wheel,

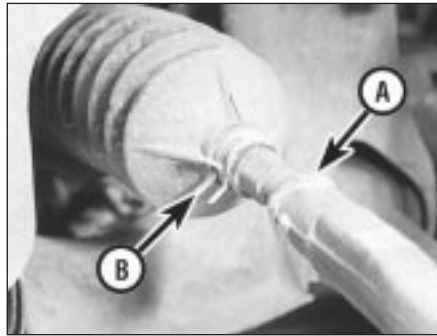

28.6 Steering track rod locknut (A) and gaiter clip (B)

pushing the car forward a little each time. Use the mean average of the three readings as the setting.

**8** Repeat this procedure until the setting is as specified, then tighten the track rod locknuts and refit the gaiter clips. Ensure that the gaiters are not twisted.

#### Rear wheel toe setting

**9** With the car on level ground and the steering in the straight-ahead position, bounce the front and rear to settle the suspension, then push the car backwards then forwards. Follow the equipment manufacturer's instructions according to the equipment being used, and check the toe setting.

**10** If adjustment is required, slacken the adjustment plate-to-trailing link retaining bolt

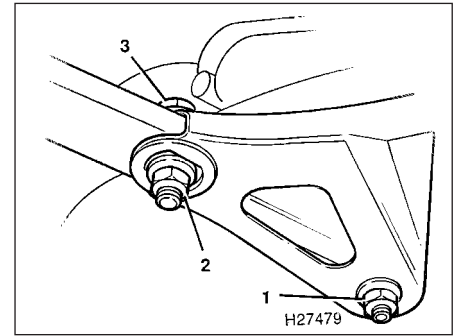

28.10 Rear wheel toe setting adjustment points

- 1 Adjustment plate retaining bolt locknut
- 2 Eccentric bolt locknut
- 3 Eccentric bolt

locknut, and the eccentric bolt locknut on each side (see illustration).

**11** Turn both eccentric bolts, by equal amounts in whichever direction is necessary, then tighten the locknuts and recheck the toe setting.

**12** If a gauge is being used, take three readings, at 120° intervals around the wheel, pushing the car forward a little each time. Use the mean average of the three readings as the setting.

**13** Repeat this procedure until the setting is as specified, then fully tighten the retaining bolt and eccentric bolt locknuts to the specified torque.







# Chapter 11 Bodywork and fittings

## Contents

Bodywork, paint and exterior trim check	See Chapter 1	Front seats - removal and refitting	42
Bonnet - removal, refitting and adjustment	6	Fuel filler flap release cable - removal and refitting	13
Bonnet lock and release cable - removal and refitting	7	General information	1
Boot lid - removal, refitting and adjustment	8	Maintenance - bodywork and underframe	2
Boot lid private lock - removal and refitting	10	Maintenance - upholstery and carpets	3
Boot lid/tailgate and fuel filler flap release control - removal and refitting	11	Major body damage - repair	5
Boot lid/tailgate lock solenoid - removal and refitting	18	Minor body damage - repair	4
Boot lid/tailgate release cable - removal and refitting	12	Radiator grille - removal and refitting	19
Boot lock - removal and refitting	9	Rear door - removal, refitting and adjustment	33
Bumpers - removal and refitting	41	Rear door exterior handle - removal and refitting	34
Centre console - removal and refitting	47	Rear door inner trim panel - removal and refitting	32
Door, boot, tailgate and bonnet check and lubrication	See Chapter 1	Rear door interior handle - removal and refitting	36
Facia - removal and refitting	48	Rear door lock - removal and refitting	35
Front door - removal, refitting and adjustment	22	Rear door window glass - removal and refitting	37
Front door cassette assembly (Coupe models) - removal and refitting	29	Rear door window lift manual regulator - removal and refitting	39
Front door exterior handle - removal and refitting	25	Rear door window lift motor - removal and refitting	38
Front door inner trim panel - removal and refitting	21	Rear quarter light glass (Coupe models) - removal and refitting	40
Front door interior handle - removal and refitting	26	Rear seats - removal and refitting	43
Front door lock - removal and refitting	23	Rear seat squab release lever and cable - removal and refitting	44
Front door mirror - removal and refitting	31	Seat belts - removal and refitting	45
Front door private lock - removal and refitting	24	Seat belt check	See Chapter 1
Front door window cable and drum assembly (Coupe models) - removal and refitting	30	Sunroof - general information	46
Front door window glass - removal and refitting	27	Tailgate - removal and refitting	14
Front door window lift motor - removal and refitting	28	Tailgate lock - removal and refitting	16
		Tailgate private lock - removal and refitting	17
		Tailgate support strut - removal and refitting	15
		Windscreen, rear window and tailgate glass - removal and refitting	20

## Degrees of difficulty

<b>Easy</b> , suitable for novice with little experience 	<b>Fairly easy</b> , suitable for beginner with some experience 	<b>Fairly difficult</b> , suitable for competent DIY mechanic 	<b>Difficult</b> , suitable for experienced DIY mechanic 	<b>Very difficult</b> , suitable for expert DIY or professional 
---	--	--	---	--

## Specifications

Torque wrench settings	Nm	lbf ft
Bonnet hinge bolts	10	7
Boot lid hinge bolts	10	7
Door hinge-to-body bolts	30	22
Door hinge-to-door bolts	22	16
Front seat retaining bolts	32	23
Seat belt retaining bolts	32	23
Bumper retaining bolts	22	16

## 1 General information

1 The bodyshell and underframe is of all-steel welded construction, and is of computer-originated design. The assembly and welding of the main body unit is completed entirely by computer-controlled robots, and the finished unit is checked for dimensional accuracy using computer and laser technology. In accordance with current practice, the bodyshell incorporates computer-calculated impact crumple zones at the front and rear, with a centre safety cell passenger compartment. During manufacture the body is dip-primed, fully sealed and undercoated, then painted with multi-layered base and top coats.

### Interior equipment electronic control unit recalibration

2 Many of the vehicles covered by this manual are equipped with sophisticated interior electrical systems utilising electronic control units (ECU's) for their operation. Whenever the battery is disconnected and reconnected, some of these systems will not work properly until a recalibration procedure is carried out to restore the values lost from the ECU memories. The systems affected and the recalibration procedure is as follows.

### Windows and sun roof

3 Operation of the windows and sun roof will be accompanied by a repetitive warning "bleep" and the "one-touch" function and "back-off" function will not operate.

4 To restore correct operation, fully open the driver's door window, in one continuous operation, using the controls on the driver's door. When the window is open fully, hold the switch in the "on" position until the warning bleep stops sounding.

5 Now shut the window, in one continuous operation, and holding the switch in the "on" position as before, until the warning bleep stops.

6 Repeat the above operations on all the other windows.

7 Fully open and then shut the sun roof, holding the switch in the "on" position at the end of each movement, until the warning bleep stops.

8 Full operation of the electric windows and sun roof should now be restored. If not, repeat the recalibration sequence.

### Lazy locking

9 The lazy locking function will not operate and instead, a warning "bleep" will sound. Full operation will be restored by carrying out the procedures for the window and sun roof memories, as described above.

### Seat and mirror positions

10 All the preset positions contained in the seat and mirror position memories will be lost.

Re-enter and save new positions using the same procedure as for the original positions.

### Radio cassette and CD player

11 The words "CODE" or "ROVER-C" will appear on the digital display and the set will not operate. Re-enter the security code as described in the Rover in-car entertainment booklet.

## 2 Maintenance - bodywork and underframe



The general condition of a vehicle's bodywork is the one thing that significantly affects its value. Maintenance is easy, but needs to be regular. Neglect, particularly after minor damage, can lead quickly to further deterioration and costly repair bills. It is important also to keep watch on those parts of the vehicle not immediately visible, for instance the underside, inside all the wheel arches, and the lower part of the engine compartment.

The basic maintenance routine for the bodywork is washing - preferably with a lot of water, from a hose. This will remove all the loose solids which may have stuck to the vehicle. It is important to flush these off in such a way as to prevent grit from scratching the finish. The wheel arches and underframe need washing in the same way, to remove any accumulated mud, which will retain moisture and tend to encourage rust. Paradoxically enough, the best time to clean the underframe and wheel arches is in wet weather, when the mud is thoroughly wet and soft. In very wet weather, the underframe is usually cleaned of large accumulations automatically, and this is a good time for inspection.

Periodically, except on vehicles with a wax-based underbody protective coating, it is a good idea to have the whole of the underframe of the vehicle steam-cleaned, engine compartment included, so that a thorough inspection can be carried out to see what minor repairs and renovations are necessary. Steam-cleaning is available at many garages, and is necessary for the removal of the accumulation of oily grime, which sometimes is allowed to become thick in certain areas. If steam-cleaning facilities are not available, there are some excellent grease solvents available which can be brush-applied; the dirt can then be simply hosed off. Note that these methods should not be used on vehicles with wax-based underbody protective coating, or the coating will be removed. Such vehicles should be inspected annually, preferably just prior to Winter, when the underbody should be washed down, and any damage to the wax coating repaired. Ideally, a completely fresh coat should be applied. It would also be worth considering the use of such wax-based protection for injection into door panels, sills, box sections, etc, as an additional safeguard against rust

damage, where such protection is not provided by the vehicle manufacturer.

After washing paintwork, wipe off with a chamois leather to give an unspotted clear finish. A coat of clear protective wax polish will give added protection against chemical pollutants in the air. If the paintwork sheen has dulled or oxidised, use a cleaner/polisher combination to restore the brilliance of the shine. This requires a little effort, but such dulling is usually caused because regular washing has been neglected. Care needs to be taken with metallic paintwork, as special non-abrasive cleaner/polisher is required to avoid damage to the finish. Always check that the door and ventilator opening drain holes and pipes are completely clear, so that water can be drained out. Brightwork should be treated in the same way as paintwork. Windscreens and windows can be kept clear of the smeary film which often appears, by the use of proprietary glass cleaner. Never use any form of wax or other body or chromium polish on glass.

## 3 Maintenance - upholstery and carpets



Mats and carpets should be brushed or vacuum-cleaned regularly, to keep them free of grit. If they are badly stained, remove them from the vehicle for scrubbing or sponging, and make quite sure they are dry before refitting. Seats and interior trim panels can be kept clean by wiping with a damp cloth. If they do become stained (which can be more apparent on light-coloured upholstery), use a little liquid detergent and a soft nail brush to scour the grime out of the grain of the material. Do not forget to keep the headlining clean in the same way as the upholstery. When using liquid cleaners inside the vehicle, do not over-wet the surfaces being cleaned. Excessive damp could get into the seams and padded interior, causing stains, offensive odours or even rot.



**If the inside of the vehicle gets wet accidentally, it is worthwhile taking some trouble to dry it out properly, particularly where carpets are involved. Do not leave oil or electric heaters inside the vehicle for this purpose.**

## 4 Minor body damage - repair



**Note:** For more detailed information about bodywork repair, Haynes Publishing produce a book by Lindsay Porter called "The Car Bodywork Repair Manual". This incorporates information on such aspects as rust treatment, painting and glass-fibre repairs, as well as details on more ambitious repairs involving welding and panel beating.

### **Repairs of minor scratches in bodywork**

If the scratch is very superficial, and does not penetrate to the metal of the bodywork, repair is very simple. Lightly rub the area of the scratch with a paintwork renovator, or a very fine cutting paste, to remove loose paint from the scratch, and to clear the surrounding bodywork of wax polish. Rinse the area with clean water.

Apply touch-up paint to the scratch using a fine paint brush; continue to apply fine layers of paint until the surface of the paint in the scratch is level with the surrounding paintwork. Allow the new paint at least two weeks to harden, then blend it into the surrounding paintwork by rubbing the scratch area with a paintwork renovator or a very fine cutting paste. Finally, apply wax polish.

Where the scratch has penetrated right through to the metal of the bodywork, causing the metal to rust, a different repair technique is required. Remove any loose rust from the bottom of the scratch with a penknife, then apply rust-inhibiting paint to prevent the formation of rust in the future. Using a rubber or nylon applicator, fill the scratch with bodystopper paste. If required, this paste can be mixed with cellulose thinners to provide a very thin paste which is ideal for filling narrow scratches. Before the stopper-paste in the scratch hardens, wrap a piece of smooth cotton rag around the top of a finger. Dip the finger in cellulose thinners, and quickly sweep it across the surface of the stopper-paste in the scratch; this will ensure that the surface of the stopper-paste is slightly hollowed. The scratch can now be painted over as described earlier in this Section.

### **Repairs of dents in bodywork**

When deep denting of the vehicle's bodywork has taken place, the first task is to pull the dent out, until the affected bodywork almost attains its original shape. There is little point in trying to restore the original shape completely, as the metal in the damaged area will have stretched on impact, and cannot be reshaped fully to its original contour. It is better to bring the level of the dent up to a point which is about 3 mm below the level of the surrounding bodywork. In cases where the dent is very shallow anyway, it is not worth trying to pull it out at all. If the underside of the dent is accessible, it can be hammered out gently from behind, using a mallet with a wooden or plastic head. Whilst doing this, hold a suitable block of wood firmly against the outside of the panel, to absorb the impact from the hammer blows and thus prevent a large area of the bodywork from being "belled-out".

Should the dent be in a section of the bodywork which has a double skin, or some other factor making it inaccessible from behind, a different technique is called for. Drill several small holes through the metal inside

the area - particularly in the deeper section. Then screw long self-tapping screws into the holes, just sufficiently for them to gain a good purchase in the metal. Now the dent can be pulled out by pulling on the protruding heads of the screws with a pair of pliers.

The next stage of the repair is the removal of the paint from the damaged area, and from an inch or so of the surrounding "sound" bodywork. This is accomplished most easily by using a wire brush or abrasive pad on a power drill, although it can be done just as effectively by hand, using sheets of abrasive paper. To complete the preparation for filling, score the surface of the bare metal with a screwdriver or the tang of a file, or alternatively, drill small holes in the affected area. This will provide a really good "key" for the filler paste.

To complete the repair, see the Section on filling and respraying.

### **Repairs of rust holes or gashes in bodywork**

Remove all paint from the affected area, and from an inch or so of the surrounding "sound" bodywork, using an abrasive pad or a wire brush on a power drill. If these are not available, a few sheets of abrasive paper will do the job most effectively. With the paint removed, you will be able to judge the severity of the corrosion, and therefore decide whether to renew the whole panel (if this is possible) or to repair the affected area. New body panels are not as expensive as most people think, and it is often quicker and more satisfactory to fit a new panel than to attempt to repair large areas of corrosion.

Remove all fittings from the affected area, except those which will act as a guide to the original shape of the damaged bodywork (eg headlight shells etc). Then, using tin snips or a hacksaw blade, remove all loose metal and any other metal badly affected by corrosion. Hammer the edges of the hole inwards, in order to create a slight depression for the filler paste.

Wire-brush the affected area to remove the powdery rust from the surface of the remaining metal. Paint the affected area with rust-inhibiting paint, if the back of the rusted area is accessible, treat this also.

Before filling can take place, it will be necessary to block the hole in some way. This can be achieved by the use of aluminium or plastic mesh, or aluminium tape.

Aluminium or plastic mesh, or glass-fibre matting, is probably the best material to use for a large hole. Cut a piece to the approximate size and shape of the hole to be filled, then position it in the hole so that its edges are below the level of the surrounding bodywork. It can be retained in position by several blobs of filler paste around its periphery.

Aluminium tape should be used for small or very narrow holes. Pull a piece off the roll, trim it to the approximate size and shape required,

then pull off the backing paper (if used) and stick the tape over the hole; it can be overlapped if the thickness of one piece is insufficient. Burnish down the edges of the tape with the handle of a screwdriver or similar, to ensure that the tape is securely attached to the metal underneath.

### **Bodywork repairs - filling and respraying**

Before using this Section, see the Sections on dent, deep scratch, rust holes and gash repairs.

Many types of bodyfiller are available, but generally speaking, those proprietary kits which contain a tin of filler paste and a tube of resin hardener are best for this type of repair. A wide, flexible plastic or nylon applicator will be found invaluable for imparting a smooth and well-contoured finish to the surface of the filler.

Mix up a little filler on a clean piece of card or board - measure the hardener carefully (follow the maker's instructions on the pack), otherwise the filler will set too rapidly or too slowly. Using the applicator, apply the filler paste to the prepared area; draw the applicator across the surface of the filler to achieve the correct contour and to level the surface. As soon as a contour that approximates to the correct one is achieved, stop working the paste - if you carry on too long, the paste will become sticky and begin to "pick-up" on the applicator. Continue to add thin layers of filler paste at 20-minute intervals, until the level of the filler is just proud of the surrounding bodywork.

Once the filler has hardened, the excess can be removed using a metal plane or file. From then on, progressively-finer grades of abrasive paper should be used, starting with a 40-grade production paper, and finishing with a 400-grade wet-and-dry paper. Always wrap the abrasive paper around a flat rubber, cork, or wooden block - otherwise the surface of the filler will not be completely flat. During the smoothing of the filler surface, the wet-and-dry paper should be periodically rinsed in water. This will ensure that a very smooth finish is imparted to the filler at the final stage.

At this stage, the "dent" should be surrounded by a ring of bare metal, which in turn should be encircled by the finely "feathered" edge of the good paintwork. Rinse the repair area with clean water, until all of the dust produced by the rubbing-down operation has gone.

Spray the whole area with a light coat of primer - this will show up any imperfections in the surface of the filler. Repair these imperfections with fresh filler paste or bodystopper, and once more smooth the surface with abrasive paper. Repeat this spray-and-repair procedure until you are satisfied that the surface of the filler, and the feathered edge of the paintwork, are perfect. Clean the repair area with clean water, and allow to dry fully.



*If bodystopper is used, it can be mixed with cellulose thinners to form a really thin paste which is ideal for filling small holes.*

The repair area is now ready for final spraying. Paint spraying must be carried out in a warm, dry, windless and dust-free atmosphere. This condition can be created artificially if you have access to a large indoor working area, but if you are forced to work in the open, you will have to pick your day very carefully. If you are working indoors, dousing the floor in the work area with water will help to settle the dust which would otherwise be in the atmosphere. If the repair area is confined to one body panel, mask off the surrounding panels; this will help to minimise the effects of a slight mis-match in paint colours. Bodywork fittings (eg chrome strips, door handles etc) will also need to be masked off. Use genuine masking tape, and several thicknesses of newspaper, for the masking operations.

Before commencing to spray, agitate the aerosol can thoroughly, then spray a test area (an old tin, or similar) until the technique is mastered. Cover the repair area with a thick coat of primer; the thickness should be built up using several thin layers of paint, rather than one thick one. Using 400-grade wet-and-dry paper, rub down the surface of the primer until it is really smooth. While doing this, the work area should be thoroughly doused with water, and the wet-and-dry paper periodically rinsed in water. Allow to dry before spraying on more paint.

Spray on the top coat, again building up the thickness by using several thin layers of paint. Start spraying at one edge of the repair area, and then, using a side-to-side motion, work until the whole repair area and about 2 inches of the surrounding original paintwork is covered. Remove all masking material 10 to 15 minutes after spraying on the final coat of paint.

Allow the new paint at least two weeks to harden, then, using a paintwork renovator, or a very fine cutting paste, blend the edges of the paint into the existing paintwork. Finally, apply wax polish.

## Plastic components

With the use of more and more plastic body components by the vehicle manufacturers (eg bumpers, spoilers, and in some cases major body panels), rectification of more serious damage to such items has become a matter of either entrusting repair work to a specialist in this field, or renewing complete components. Repair of such damage by the DIY owner is not really feasible, owing to the cost of the equipment and materials required for effecting such repairs. The basic technique involves making a groove along the line of the crack in the plastic, using a rotary burr in a power drill. The damaged part is then welded back together, using a hot-air gun to heat up and fuse a plastic filler rod into the groove. Any excess plastic is then removed, and the area rubbed down to a smooth finish. It is important that a filler rod of the correct plastic is used, as body components can be made of a variety of different types (eg polycarbonate, ABS, polypropylene).

Damage of a less serious nature (abrasions, minor cracks etc) can be repaired by the DIY owner using a two-part epoxy filler repair material. Once mixed in equal proportions, this is used in similar fashion to the bodywork filler used on metal panels. The filler is usually cured in twenty to thirty minutes, ready for sanding and painting.

If the owner is renewing a complete component himself, or if he has repaired it with epoxy filler, he will be left with the problem of finding a suitable paint for finishing which is compatible with the type of plastic used. At one time, the use of a universal paint was not possible, owing to the complex range of plastics encountered in body component applications. Standard paints, generally speaking, will not bond to plastic or rubber satisfactorily. However, it is now possible to obtain a plastic body parts finishing kit which consists of a pre-primer treatment, a primer and coloured top coat. Full instructions are normally supplied with a kit, but basically, the method of use is to first apply the pre-primer to the component concerned, and allow it to dry for up to 30 minutes. Then the primer is applied, and left to dry for about an hour before finally applying the special-coloured

top coat. The result is a correctly-coloured component, where the paint will flex with the plastic or rubber, a property that standard paint does not normally possess.

## 5 Major body damage - repair



Where serious damage has occurred, or large areas need renewal due to neglect, it means that complete new panels will need welding in; this is best left to professionals. If the damage is due to impact, it will also be necessary to check completely the alignment of the bodyshell; this can only be carried out accurately by a Rover dealer using special jigs. If the body is left misaligned, it is primarily dangerous as the car will not handle properly and secondly, uneven stresses will be imposed on the steering, suspension and possibly transmission, causing abnormal wear or complete failure, particularly to items such as the tyres.

## 6 Bonnet - removal, refitting and adjustment



### Removal

- 1 Open the bonnet and remove the sound-deadening material on the left-hand side by releasing the clip retainers (**see illustration**).
- 2 Undo the two screws securing the illumination light to the bonnet, feed the lamp and wiring down behind the sound-deadening material and retrieve it from the bottom of the bonnet (**see illustration**). Place the light and wiring to one side.
- 3 Disconnect the windscreen washer fluid feed hose at the two-way connector (**see illustration**).
- 4 Place some rags beneath the bonnet corners, by the hinges.
- 5 Mark the position of the hinges by drawing around them with a soft pencil, then loosen the retaining bolts.
- 6 Engage the help of an assistant to support the bonnet.

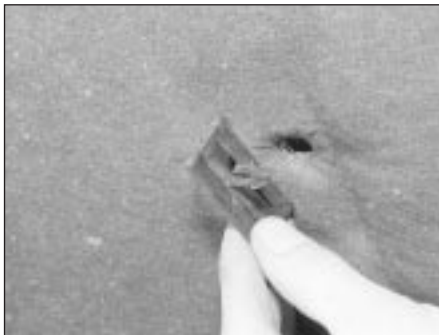

6.1 Remove the sound-deadening material by releasing the clip retainers



6.2 Remove the under-bonnet illumination light



6.3 Disconnect the windscreen washer fluid feed hose (arrowed)





6.7 Prise out the support strut retaining clips

7 Using a small screwdriver, prise out the clips securing the support struts to the pegs on the bonnet (see illustration). Release both struts from their pegs.

8 Undo the retaining bolts and carefully lift away the bonnet.

### Refitting

9 Refitting is a reversal of removal; adjust the bonnet on the hinges to its original position, then check the alignment as follows.

### Adjustment

10 Close the bonnet and check the alignment with the adjacent body panels. The bonnet can be moved forward and backward by adjusting its position at each hinge. If the bonnet is too low with respect to the adjacent wing, fit small shims between the hinge and bonnet.

11 Check the bonnet closure and ease of opening. If the striker pins do not engage smoothly with the lock plates, slacken the striker plate retaining bolts and reposition the plates. If necessary, slacken the locknut and adjust the striker pin height by turning the slotted end with a screwdriver.

## 7 Bonnet lock and release cable - removal and refitting



### Removal

1 From inside the car, undo the bolts and withdraw the release lever from the right-hand side of the footwell.

2 Disengage the cables from the lever.

3 Working in the engine compartment, undo the bolts securing the relevant bonnet lock to the front body panel.

4 Withdraw the lock from under the body panel and disengage the release cable.

5 Release the cable from the retaining clips and ties in the engine compartment, and from the bulkhead grommet.

6 Feed the cable through into the engine compartment and remove it from the car.

### Refitting

7 Refitting is a reversal of removal. Adjust the bonnet lock as described in Section 6, if necessary.

## 8 Boot lid - removal, refitting and adjustment



### Removal

1 Open the boot lid and remove the plastic cover over the lock.

2 Release the retaining clip and disconnect the link rod from the lock lever.

3 Disconnect the wiring at the connector adjacent to the lock.

4 Undo the two bolts and withdraw the lock from the boot lid.

5 Withdraw the lock release cable outer sheath from the lock bracket, and disconnect the inner cable from the lock lever.

6 Withdraw the grommet from the cable entry point above the boot lid hinge, and release the cable from the hinge cable clips and ties. Withdraw the release cable and wiring.

7 With an assistant supporting the boot lid, undo the four hinge bolts and lift the boot lid away.

### Refitting

8 Refitting is a reversal of removal. Engage the centre groove of the lock release cable sheath into the lock bracket slot initially, but use an alternative groove if the release lever action is unsatisfactory.

### Adjustment

9 With the boot lid closed, check the relationship of the lid with the adjacent panels. If necessary, the boot can be repositioned by altering the position of the hinges at their body attachment. To do this, remove the rear seats as described in Section 43, and remove the parcel shelf. Slacken the hinge nuts and reposition the hinges as required. Tighten the nuts, then close the boot lid and check the operation of the lock. If necessary, slacken the striker plate bolts, reposition the striker plate and tighten the bolts (see illustration).

10 Refit the parcel shelf and rear seats on completion.

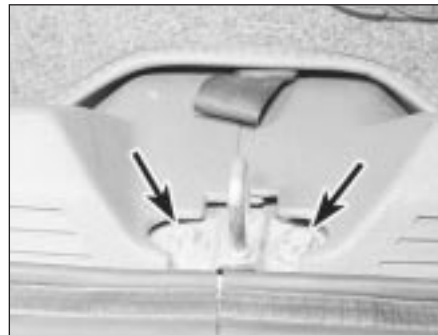

8.9 Boot lid striker plate retaining bolts (arrowed)

## 9 Boot lock - removal and refitting



### Removal

1 On later models, remove the boot lid/tailgate lock solenoid as described in Section 18.

2 Remove the plastic cover over the lock (see illustration).

3 Where applicable, release the retaining clip and disconnect the link rod from the lock lever.

4 Disconnect the wiring at the connector adjacent to the lock.

5 Undo the two bolts and withdraw the lock from the boot lid.

6 Withdraw the lock release cable outer sheath from the lock bracket, disconnect the inner cable from the lock lever, and remove the lock.

### Refitting

7 Refitting is a reversal of removal. Engage the centre groove of the lock release cable sheath into the lock bracket slot initially, but use an alternative groove if the release lever action is unsatisfactory.

## 10 Boot lid private lock - removal and refitting



### Pre-1992 model year

#### Removal

1 Remove the number plate from the boot lid.

2 From inside the boot lid, undo the screws

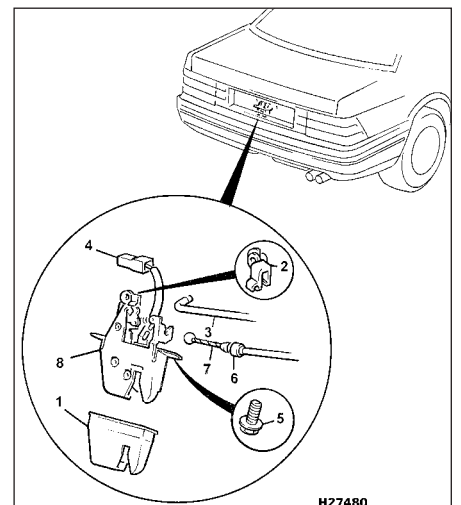

9.2 Boot lock attachments - early models shown, later models similar

- |                           |                              |
|---------------------------|------------------------------|
| 1 Plastic cover           | 5 Lock retaining bolts       |
| 2 Link rod retaining clip | 6 Release cable outer sheath |
| 3 Link rod                | 7 Inner cable                |
| 4 Wiring connector        | 8 Boot lock                  |



10.2 Undo the centre lens and reflector retaining screw

and remove the centre lens and reflector assembly (see illustration).

3 Extract the retaining circlip from the private lock lever, and withdraw the link rod.

4 Drill out the three retaining rivets, and remove the private lock from the boot lid (see illustration).

**Refitting**

5 Refitting is a reversal of removal.

**1992 model year onwards**

**Removal**

6 Remove the boot lock as described in Section 9.

7 Disconnect the private lock wiring multiplug.

8 Extract the retaining clip and withdraw the private lock from the boot lid.

**Refitting**

9 Refitting is a reversal of removal.

**11 Boot lid/tailgate and fuel filler flap release control - removal and refitting**



**Removal**

1 Withdraw the knobs from the release levers inside the car (see illustration).

2 Undo the two screws securing the release control cover - one on the side face, and one under a flap at the rear (see illustration).

3 Withdraw the cover retaining stud on the



11.2 Undo the release lever control cover retaining screws



10.4 Boot lid private lock retaining rivets

inner face, then lift the cover off the release control (see illustrations).

4 Undo the screws securing the front sill tread plate, lift off the tread plate, and pull back the carpet around the release control.

5 Undo the three screws and withdraw the release control.

6 Disconnect the inner cable end(s) and outer cable sheath(s) and, if applicable, the wiring connectors. Remove the control from the car.

**Refitting**

7 Refitting is a reversal of removal. Note that on models with twin cables, the boot/tailgate release cable with the single groove in the outer cable sheath is fitted to the upper location, and the fuel filler flap release with the three grooves in the outer cable sheath is fitted to the lower location. Engage the centre groove with the bracket when fitting the filler flap cable, and check the release operation. If unsatisfactory, use an alternate groove.

**12 Boot lid/tailgate release cable - removal and refitting**



**Removal**

1 Remove the boot lid/tailgate and fuel filler flap release control as described in Section 11.

2 Undo the screws securing the rear sill tread plate, lift off the tread plate and move aside the carpet around the sill.



11.3a Withdraw the cover . . .



11.1 Withdraw the boot lid/tailgate and fuel filler flap release lever knobs

3 Remove the rear seat as described in Section 42.

4 On Saloon models, open the boot lid and remove the plastic cover over the lock. On Fastback models, open the tailgate, release the screw studs and remove the tailgate inner trim panel.

5 Release the retaining clip and disconnect the link rod from the lock lever.

6 Disconnect the wiring at the connector adjacent to the lock.

7 Undo the two bolts and withdraw the lock from the boot lid/tailgate.

8 Withdraw the lock release cable outer sheath from the lock bracket, and disconnect the inner cable from the lock lever.

9 Withdraw the grommet from the cable entry point and release the cable from the cable clips and ties.

10 Withdraw the release cable from the boot lid/tailgate.

11 Tie a drawstring to the release control end of the cable, and pull the cable into the luggage compartment. Untie the drawstring and remove the release cable from the car.

**Refitting**

12 Tie the drawstring to the new cable, and pull it through into the car interior.

13 Refit the cable to the release lever and lock, then reassemble the components using a reversal of removal. When refitting the cable to the lock, engage the centre groove of the cable sheath into the lock bracket slot initially, but use an alternative groove if the release lever action is unsatisfactory.

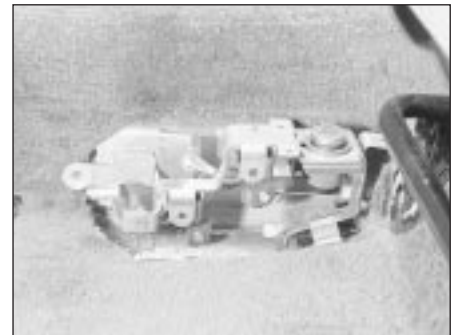

11.3b . . . for access to the release control assembly



15.2a Extract the support strut wire spring retainer . . .



15.2b . . . and release the strut from the stud



15.3 Release the strut lower end from its stud

### 13 Fuel filler flap release cable - removal and refitting



#### Removal

- 1 Open the fuel filler flap, then remove the boot lid/tailgate and fuel filler flap release control, as described in Section 11.
- 2 Undo the screws securing the rear sill tread plate, lift off the tread plate and move aside the carpet around the sill.
- 3 Remove the rear seat as described in Section 43.
- 4 Extract the retaining clip securing the cable end at the filler flap end, and push the cable through into the luggage compartment.
- 5 Release the cable from the retaining clips, and pull it into the car interior.



16.1 Release the screw studs and remove the tailgate inner trim panel

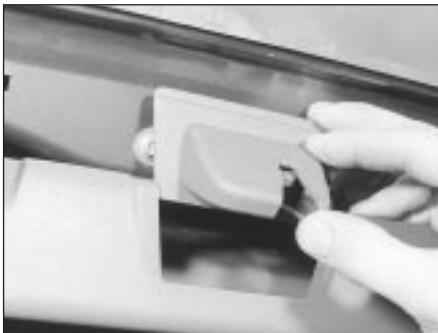

16.3 Remove the plastic cover from the lock

6 Where fitted, undo the screws and remove the cover strip over the cable beneath the rear seat location.

7 Release the cable from any further clips and ties, and remove it from the car.

#### Refitting

8 Refitting is a reversal of removal, with reference to Section 11 when refitting the cable to the release control.

### 14 Tailgate - removal and refitting



#### Removal

- 1 Open the tailgate and release the parcel shelf support strings.
- 2 From inside the car, remove the headliner rear finisher for access to the tailgate hinge retaining nuts.
- 3 Disconnect the screen washer hose, and the tailgate wiring harness connectors.
- 4 Support the tailgate with the help of an assistant, or using a prop.
- 5 Extract the wire spring retainer securing each support strut to its tailgate ball-stud, and release the struts.
- 6 Undo the tailgate hinge retaining nuts and remove the tailgate from the car.

#### Refitting

7 Refitting is a reversal of removal, in conjunction with the following adjustment procedure.

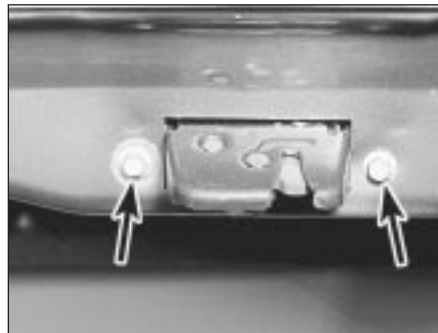

16.6 Undo the two lock retaining bolts (arrowed)

8 With the tailgate closed, check the relationship of the tailgate with the adjacent panels. If necessary, it can be repositioned by altering the position of the hinges at their body attachment. Slacken the hinge nuts, and reposition the hinges are required. Tighten the nuts, then close the tailgate and check the operation of the lock. If necessary, slacken the striker plate bolts, reposition the striker plate and tighten the bolts.

### 15 Tailgate support strut - removal and refitting



#### Removal

- 1 Open the tailgate and support it with the help of an assistant, or using a prop.
- 2 Extract the wire spring retainer securing the upper end of the support strut to its ball-stud, and release the strut (see illustrations).
- 3 Release the strut lower end clip, ease the strut from its stud and remove it from the car (see illustration).
- 4 Refitting is a reversal of removal.

### 16 Tailgate lock - removal and refitting



#### Removal

- 1 Open the tailgate, release the screw studs and remove the tailgate inner trim panel (see illustration).
- 2 On later models, remove the boot lid/tailgate lock solenoid as described in Section 18.
- 3 Remove the plastic cover from the lock (see illustration).
- 4 Where applicable, release the retaining clip and remove the link rod from the lock lever.
- 5 Disconnect the wiring multiplugs at the harness connectors, or the two wires at the lock as applicable.
- 6 Undo the two lock retaining bolts and withdraw the lock from the tailgate (see illustration).
- 7 Where applicable, withdraw the lock



17.4 Private lock lever retaining circlip (arrowed) on early models

release cable outer sheath from the lock bracket and disconnect the inner cable from the lock lever

**Refitting**

8 Refitting is a reversal of removal.

**17 Tailgate private lock - removal and refitting**



**Pre-1992 model year**

**Removal**

- 1 Open the tailgate, release the screw studs and remove the tailgate inner trim panel.
- 2 Remove the number plate from the tailgate.
- 3 From inside the tailgate, undo the screws and remove the centre lens and reflector assembly.
- 4 Extract the retaining circlip from the private lock lever, and withdraw the lever from the lock (see illustration).
- 5 Drill out the three retaining rivets and remove the private lock from the tailgate.

**Refitting**

6 Refitting is a reversal of removal.

**1992 model year onwards**

**Removal**

7 Remove the tailgate lock as described in Section 16.



19.2 ... and release the two lower retaining clips



17.9 Private lock component attachments on later models

8 Disconnect the private lock wiring multiplug.

9 Extract the retaining clip and withdraw the private lock from the tailgate (see illustration).

**Refitting**

10 Refitting is a reversal of removal.

**18 Boot lid/tailgate lock solenoid - removal and refitting**



**Removal**

- 1 Open the boot lid/tailgate, release the screw studs and remove the inner trim panel.
- 2 On early models, remove the number plate from the tailgate then undo the screws and remove the centre lens and reflector assembly.
- 3 Disconnect the solenoid wiring multiplug.
- 4 Undo the two screws and remove the solenoid.



19.1 On early models, undo the radiator grille upper retaining screws (arrowed) . . .

**Refitting**

6 Refitting is a reversal of removal.

**19 Radiator grille - removal and refitting**



**Pre-1992 model year**

**Removal**

- 1 Undo the four grille upper retaining screws (see illustration).
- 2 Release the two lower retaining clips and withdraw the grille from the car (see illustration).

**Refitting**

3 Refitting is a reversal of removal.

**1992 model year onwards**

**Removal**

4 Carefully prise out the Rover motif from the centre of the grille (see illustration).

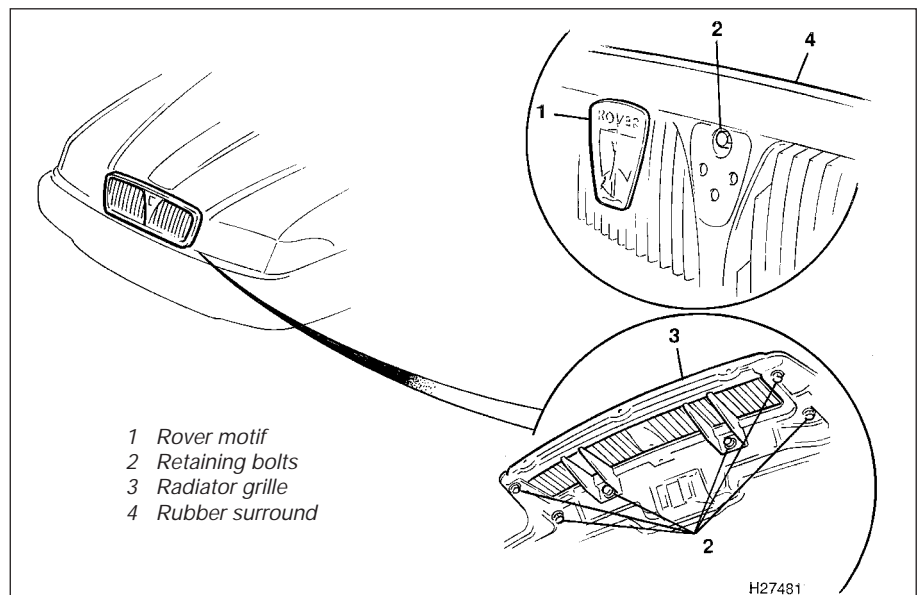

19.4 Radiator grille attachments on later models

H27481





21.1a Prise apart the interior lock button . . .



21.1b . . . and lift out the outer half . . .



21.1c . . . followed by the inner half

5 Open the bonnet and undo the seven bolts securing the grille panel.

6 Remove the grille from the bonnet and recover the rubber surround.

**Refitting**

7 Refitting is a reversal of removal.

scope of the home mechanic. If it is necessary to have windscreen, rear window or tailgate window glass removed, this job should be left to a suitably-equipped specialist.

2 On early models, carefully prise out the finisher trim from the inner handle, disconnect the tweeter speaker leads and remove the finisher (see illustrations).

3 On later models, prise out the door inner handle centre finisher trim, and undo the two screws securing the trim surround to the door. Pull the door handle outwards, and manipulate the trim surround off the handle and door panel (see illustrations). Disconnect the tweeter speaker leads from the rear of the trim surround, and remove the surround.

4 Prise out the blanking plate or interior light from the trim panel, and where applicable, disconnect the wiring and remove the light.

5 Undo the screw at the top of the door pull below the interior handle (see illustration).

**20 Windscreen, rear window and tailgate glass - removal and refitting**



**21 Front door inner trim panel - removal and refitting**



**Removal**

1 Insert a small screwdriver into the slot at the rear of the interior locking button, and prise apart the outer moulded half of the locking button. Lift off the outer half, then remove the inner half from the locking rod (see illustrations).



21.2a On early models, prise out the inner handle finisher trim . . .



21.2b . . . and disconnect the tweeter speaker leads



21.3a On later models, prise out the inner handle centre finisher trim . . .



21.3b . . . and undo the trim surround screws



21.3c Manipulate the surround off the handle



21.5 Undo the screw at the top of the door pull

## 11•10 Bodywork and fittings

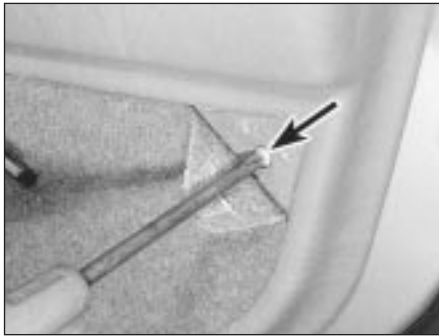

21.6a Undo the bottom screw behind the padded trim . . .



21.6b . . . or behind the plastic cap



21.7a Pull out the blanking plug . . .



21.7b . . . and undo the recessed rear side screw

6 Ease back the padded trim at the bottom of the panel, or lift off the plastic cap, to expose the retaining screw, then undo the screw (see illustrations).

7 Pull out the blanking plug on the rear side of the panel, and undo the recessed screw behind (see illustrations).

8 Undo the screw at the upper front corner of the panel (see illustration).

9 Undo the screw at each end of the storage bin (see illustrations).

10 Working through the blanking plate or interior light aperture, undo the screw in the recess (see illustration).

11 Where fitted, undo the screw from the

bottom of the door pull finger grip, and remove the finger grip from the panel.

12 If the panel incorporates a moulded door pull, prise out the blanking plug and undo the recessed screw behind (see illustrations).

13 Where applicable, release the rubber boot over the door mirror adjustment stalk, release the stalk retaining clips and push the stalk through to the inside of the panel (see illustrations).

14 Using a flat tool or your fingers, release the eight studs securing the panel to the door by prising the panel out, or sharply pulling it out, in the vicinity of each stud. Lift the panel



21.8 Undo the screw at the front corner



21.9a Undo the storage bin front screw . . .



21.9b . . . and rear screw



21.10 Undo the screw behind the blanking plate or interior light



21.12a If the panel has a moulded door pull, prise out the blanking plug . . .



21.12b . . . and undo the recessed screw behind



21.13a Release the rubber boot over the manual door mirror adjustment stalk . . .



21.13b . . . release the stalk retaining clips and push the stalk through the panel



21.14 Withdraw the panel from the door

upwards and withdraw it from the door (see illustration).

15 Disconnect the switch panel wiring multiplug from the rear of the panel and remove the panel.

**Refitting**

16 Refitting is a reversal of removal.

**22 Front door - removal, refitting and adjustment**



**Removal**

1 Remove the front door inner trim panel as described in Section 21.

2 Release the masking tape and carefully



22.4 Tap out the door check strap retaining roll pin (arrowed)



22.8 Door striker plate retaining screws (arrowed)

peel back the polythene condensation barrier for access to the internal wiring multiplugs.

3 Identify the multiplugs for refitting, then disconnect them from the door components. Withdraw the wiring harness from the door.

4 Using a drift, tap out the door check strap retaining roll pin (see illustration).

5 With the help of an assistant, support the door on a padded jack, undo the four hinge retaining bolts and withdraw the door from the car.

**Refitting**

6 Refitting is a reversal of removal.

**Adjustment**

7 Check the fit of the door against the surrounding panels, and if necessary slacken the hinge bolts and reposition the door.

8 When the door fit is correct, check the operation of the lock, and if necessary slacken

the striker plate screws and reposition the striker plate (see illustration). Tighten all the bolts and screws securely on completion.

**23 Front door lock - removal and refitting**



**Saloon and Fastback models**

**Removal**

1 Remove the front door inner trim panel as described in Section 21.

2 Release the masking tape and carefully peel back the polythene condensation barrier as necessary for access to the door lock area.

3 Carefully prise out the door lock link rod and control rod from their attachments at the private lock lever and exterior handle lever respectively (see illustration).

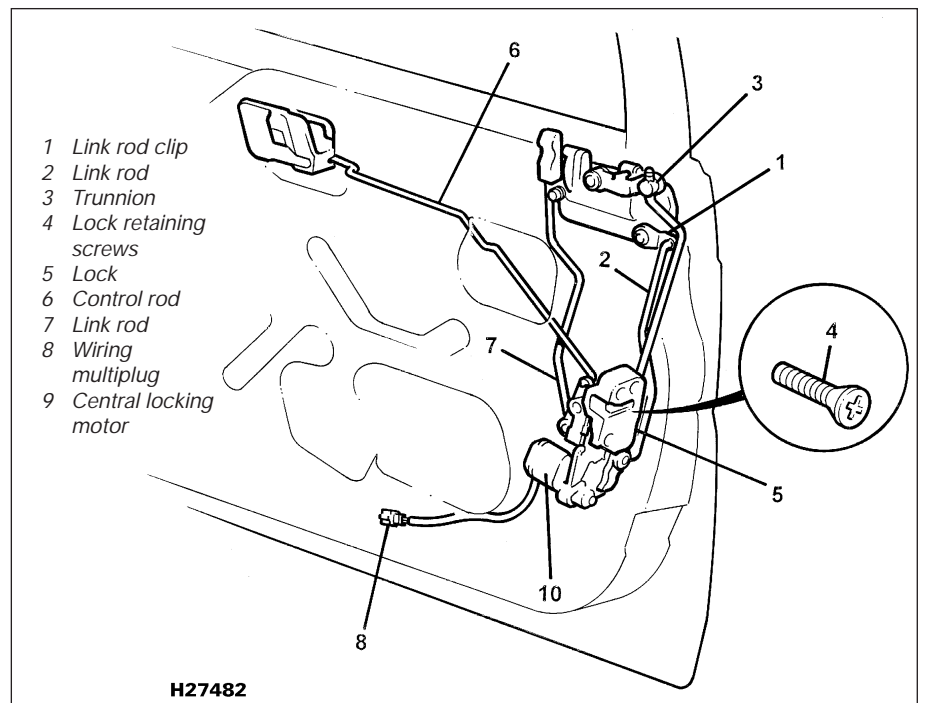

H27482

23.3 Front door lock attachments - Saloon and Fastback models shown, Coupe similar

## 11•12 Bodywork and fittings

4 Undo the three screws securing the lock assembly to the door.

5 Lower the lock assembly, and release the interior handle control rod and locking button rod from the lock levers.

6 Disconnect the central locking motor wiring multiplug, and manipulate the lock assembly from the door.

### Refitting

7 Refitting is a reversal of removal.

### Coupe models

#### Removal

8 Remove the front door cassette assembly as described in Section 29.

9 Carefully prise out the door lock link rod and control rod from their attachments at the private lock lever and exterior handle lever respectively.

10 Undo the screw securing the interior lock button control rod bellcrank.

11 Withdraw the bellcrank from the door, and disconnect the door lock control rod.

12 Release the cable tie from the central locking motor wiring harness and disconnect the harness multiplug.

13 Undo the three screws securing the lock assembly to the door.

14 Withdraw the lock assembly, and disconnect the interior handle control cable from the lock. Release the cable from the lock shield and remove the lock assembly.

### Refitting

15 Refitting is a reversal of removal.

### 24 Front door private lock - removal and refitting



### Saloon and Fastback models

#### Removal

1 Remove the front door inner trim panel as described in Section 21.

2 Release the masking tape and carefully peel back the polythene condensation barrier as necessary for access to the door lock area.

3 Extract the circlip from the end of the lock barrel, and remove the washer, plate and operating lever (see illustration).

4 Where applicable, release the wiring harness retaining clip and disconnect the harness multiplug.

5 Extract the private lock retaining wire clip, and withdraw the lock from the outside of the door.

### Refitting

6 Refitting is a reversal of removal.

### Coupe models

#### Removal

7 Remove the front door cassette assembly as described in Section 29.

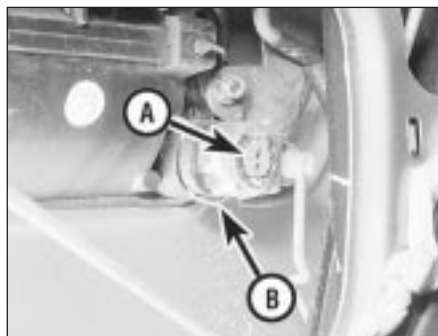

24.3 Lock barrel operating lever retaining circlip (A) and private lock retaining wire clip (B)

8 Carefully prise out the door lock link rod from the private lock lever.

9 Release the wiring harness from the clip at the bottom of the door, then disconnect the multiplug at the harness connector.

10 Extract the private lock retaining clip and remove the lock from the door handle.

### Refitting

11 Refitting is a reversal of removal.

### 25 Front door exterior handle - removal and refitting

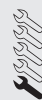

### Saloon and Fastback models

#### Removal

1 Remove the front door private lock as described in Section 24.

2 Carefully prise out the door lock control rod from the exterior handle lever.

3 Undo the two retaining bolts and remove the handle from the outside of the door (see illustration).

### Refitting

4 Refitting is a reversal of removal.

### Coupe models

#### Removal

5 Remove the front door cassette assembly as described in Section 29.



26.2 Remove the foam pad from the interior handle



25.3 Front door exterior handle retaining bolts (arrowed)

6 Extract the private lock retaining clip and remove the lock from the door handle.

7 Carefully prise out the door lock control rod from the exterior handle lever.

8 Remove the blanking plug on the inside of the door for access to the outer retaining bolt.

9 Undo the two retaining bolts and remove the handle from outside of the door. Collect the two rubber washers as the handle is removed.

### Refitting

10 Refitting is a reversal of removal.

### 26 Front door interior handle - removal and refitting



### Pre-1992 model year

#### Removal

1 Remove the front door inner trim panel as described in Section 21.

2 Remove the foam pad from the handle (see illustration).

3 Where applicable, undo the screws securing the handle to the door panel.

4 Lift the locking tab at the front of the handle body, slide the handle rearwards and withdraw it from the door (see illustration).

5 Disconnect the operating rod and remove the handle.

### Refitting

6 Refitting is a reversal of removal.



26.4 Withdraw the handle from the door





27.2a Prise up the door panel waist seal . . .



27.2b . . . and release the retaining clips



27.6a Release the wiring loom retaining clips . . .

**1992 model year onwards**

**Removal**

- 7 Remove the front door inner trim panel as described in Section 21.
- 8 Undo the four screws securing the handle to the door panel.
- 9 Slide the handle forward and withdraw it from the door.
- 10 Disconnect the interior handle control rod or cable and remove the handle.

**Refitting**

- 11 Refitting is a reversal of removal.

**27 Front door window glass - removal and refitting**

**Saloon and Fastback models**

**Removal**

- 1 Remove the front door inner trim panel as described in Section 21.
- 2 Using a screwdriver and protective rag, carefully prise up the waist seal from the upper edge of the door panel to release the retaining clips (see illustrations).
- 3 Remove the front door main speaker, referring to Chapter 12 if necessary.
- 4 Where fitted, undo the three screws and



27.7 Undo the three screws and move the relay plate and relays aside

- remove the trim panel support bracket.
- 5 Release the masking tape securing the wiring loom and loom connectors to the door panel.
- 6 Release the wiring loom retaining clips and ease the loom away from the door (see illustrations).
- 7 Undo the three screws securing the relay mounting plate, then move the plate and relays aside (see illustration).
- 8 Carefully peel back the condensation barrier, and pull it downwards to provide access inside the door.
- 9 Lower the window until the two glass-to-lifting member retaining bolts are accessible through one of the door apertures.
- 10 Undo the two bolts securing the door glass to the lifting member, and lift the glass up and out of the door (see illustration).

**Refitting**

- 11 Refitting is a reversal of removal. Ensure that the condensation barrier is refitted securely over the entire door panel face, and position the waist seal retaining clips in the waist seal before refitting the seal to the door (see illustration).

**Coupe models**

**Removal**

- 12 Open the window half way, then remove the front door cassette assembly as described in Section 29.



27.10 Lift the glass up and out of the door



27.6b . . . and ease the loom away from the door

- 13 With the cassette assembly on the bench with the glass side upwards, undo the Torx screws and remove the two glass clamping plates (see illustration).
- 14 Remove the clamping plate plastic shims.
- 15 Carefully lift the window glass off the lifting plates and remove the plastic shims. If the plastic shims have metal spacers attached, ensure that the plastic shims and metal spacers remain together with their respective clamping plates.

**Refitting**

- 16 Refit the door glass to the cassette assembly using a reversal of removal.
- 17 With the help of an assistant, lift up the cassette assembly and hold it in a vertical position. Using a slave battery, fused switch



27.11 Position the waist seal retaining clips in the waist seal before refitting the seal to the door

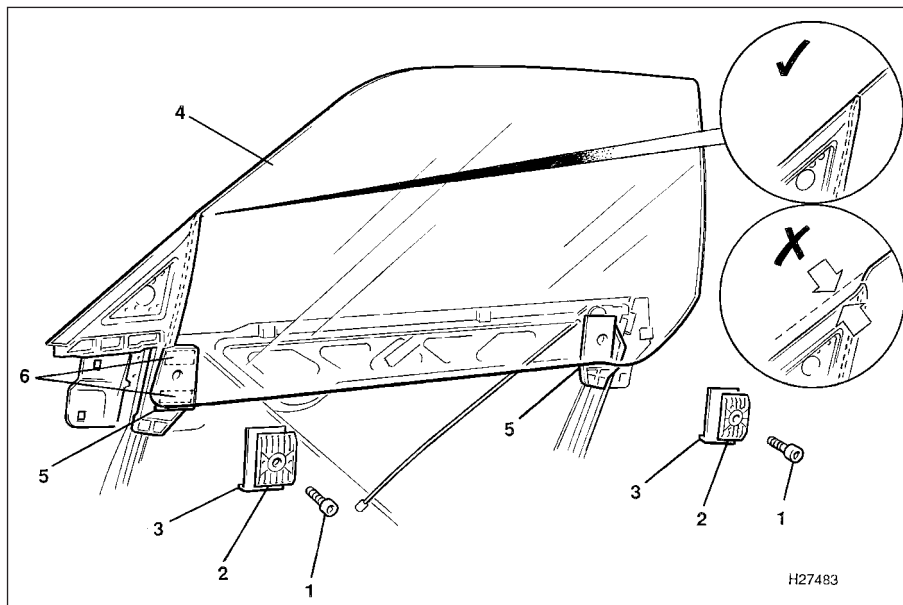

27.13 Front door glass attachment details on Coupe models

- |                                   |   |   |
|-----------------------------------|---|---|
| 1 Clamping plate retaining screws | 4 Door glass  | <i>Inset shows correct and incorrect door glass-to-cheater panel adjustment</i> |
| 2 Clamping plates                 | 5 Lifting plate plastic shims                             |   |
| 3 Clamping plate plastic shims    | 6 Lifting plate plastic shim metal spacers (where fitted) |   |

and wiring, connect the window lift motor to the battery and close the window fully.

18 With the window closed, check that the front edge of the glass and the cheater panel are flush, forming a smooth curve (see illustration 27.13). If this is not the case, it will be necessary to obtain additional metal spacers and position these behind the top or bottom of the front lifting plate shims as necessary, on a trial and error basis.

19 Once the initial adjustment is correct, refit the cassette assembly as described in Section 29.

**28 Front door window lift motor - removal and refitting**



**Removal**

- 1 Remove the front door window glass as described in Section 27.
- 2 Disconnect the motor wiring multiplug.
- 3 Undo the two lower bolts and one upper bolt securing the lifting channel to the door.
- 4 Undo the three motor-to-door securing nuts, and manipulate the motor and lifting channel through the lower aperture (see illustrations).

**Refitting**

- 5 Refitting is a reversal of removal.

**29 Front door cassette assembly (Coupe models) - removal and refitting**



**Note:** *Once the door cassette assembly is disturbed, it will be necessary to carry out an elaborate adjustment procedure after refitting, to ensure that a leak, noise and draught free seal is obtained when the window glass is closed. This adjustment entails the use of Rover special tools and gauges and can only be successfully carried out by a suitably equipped dealer.*

**Removal**

- 1 Remove the door inner trim panel as described in Section 21.
- 2 Remove the door mirror as described in Section 31.

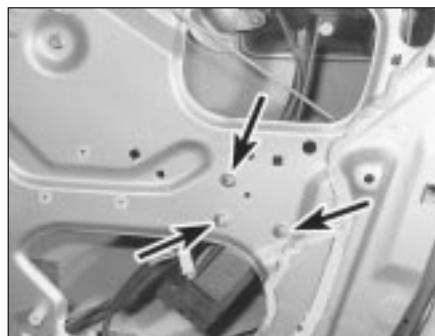

28.4a Undo the three window lift motor retaining nuts (arrowed) . . .



28.4b . . . and remove the motor from the door

- 3 Remove the door speaker, referring to Chapter 12 if necessary.
- 4 Undo the three screws and remove the inner trim panel attachment bracket.
- 5 Carefully prise out the clips securing the wiring multiplugs to the door.
- 6 Release the two clips and remove the plastic condensation barrier.
- 7 Undo the three screws and release the interior handle from the door.
- 8 Release the window lift motor wiring multiplug from the door clip and disconnect it.
- 9 Undo the three nuts and release the window lift motor studs from the door.
- 10 Undo the two bolts securing the lower edge of the cassette assembly to the door.
- 11 At the top, undo the three bolts at the front, and two at the rear securing the cassette assembly to the door.
- 12 With the help of an assistant, carefully lift the cassette assembly out of the door. Take care not to lift or support the cassette assembly using the cheater panel in front of the window glass as this may cause the panel to move out of alignment.

**Refitting**

13 Refitting is a reversal of removal, but have the cassette assembly and door glass accurately adjusted by a Rover dealer on completion.

**30 Front door window cable and drum assembly (Coupe models) - removal and refitting**



**Removal**

- 1 Remove the door window glass as described in Section 27.
- 2 At the bottom front corner of the cassette assembly, note the fitted position of the outer cable retainer in the support bracket. Turn the retainer through 90° to release it from the bracket.
- 3 Bend the guide tabs away from the lower front pulley and slip the cable off the pulley.
- 4 Release the lifting plate from the front runner.
- 5 Release the cable from the front upper pulley.

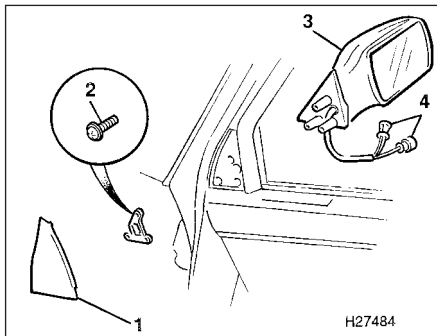

**31.6 Electrically controlled front door mirror attachments**

- 1 Trim panel                      3 Mirror  
2 Retaining screws          4 Wiring multiplugs

6 At the top rear corner of the cassette assembly, note the fitted position of the outer cable retainer in the support bracket. Turn the retainer through 90° to release it from the bracket.

7 Bend the guide tab away from the lower rear pulley and slip the cable off both rear pulleys.

8 Release the outer cable from the clip.

9 Detach the cable ends from the glass rear lifting plate.

10 Mark the position of the cable exit points on the cable drum cover plate, then undo the screws and lift off the plate.

11 Taking care not to allow the cable to become detached from the drum, lift the cable and drum assembly out of the cassette assembly.

### Refitting

12 Refitting is a reversal of removal bearing in mind the following points.

- Lubricate the pulleys with Molykote PG65 prior to refitting.
- Refit the outer cable retainers to the same positions in the support brackets as noted during removal.
- Ensure that the diagonal cable run is positioned over the outer cable and motor assembly, between the inner cable and the window glass.

### 31 Front door mirror - removal and refitting



### Manually controlled mirror

#### Removal

1 Remove the front door inner trim panel as described in Section 21.

2 Carefully prise off the triangular trim panel from the upper corner of the door.

3 Undo the three mirror retaining screws, release the cables from their retaining strap inside the door, and remove the mirror and cables from the door.

#### Refitting

4 Refitting is a reversal of removal.

### Electrically controlled mirror

#### Removal

5 Remove the front door inner trim panel as described in Section 21.

6 Carefully prise off the triangular trim panel from the upper corner of the door (see illustration).

7 Peel back the condensation barrier as necessary to gain access to the mirror wiring multiplugs, then disconnect them.

8 Undo the three mirror retaining screws and withdraw the mirror from the door.

#### Refitting

9 Refitting is a reversal of removal.

### 32 Rear door inner trim panel - removal and refitting

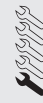

**Note:** Many of the attachment points and component fittings are similar to those of the front door inner trim panel. Refer to Section 21 for useful photographic details.

### Models with electrically operated rear windows

#### Removal

1 Insert a small screwdriver or similar tool into the slot at the rear of the interior locking button, and prise apart the outer moulded half of the locking button. Lift off the outer half, then remove the inner half from the locking rod.

2 Prise out the door inner handle centre finisher trim, and undo the two screws securing the trim surround to the door.

3 Pull the door handle outwards, and manipulate the trim surround off the handle and door panel.

4 Carefully prise out the blanking plate or interior light from the bottom of the panel. If applicable, disconnect the wiring and remove the light.

5 Lift off the plastic caps and undo the two screws around the lower rear portion of the panel.

6 Working through the blanking plate or interior light aperture, undo the screw in the recess.

7 Undo the screw at the top of the door pull below the interior handle.

8 Using a flat tool or your fingers, release the studs securing the panel to the door by prising the panel out, or sharply pulling it out, in the vicinity of each stud. Lift the panel upwards and withdraw it from the door.

9 Disconnect the wiring multiplug at the rear of the window lift switch and remove the panel.

#### Refitting

10 Refitting is a reversal of removal.

### Models with manually operated rear windows

#### Removal

11 Insert a small screwdriver into the slot at the rear of the interior locking button, and prise apart the outer moulded half of the locking button. Lift off the outer half, then remove the inner half from the locking rod.

12 Prise out the door inner handle centre finisher trim, and undo the two screws securing the trim surround to the door.

13 Pull the door handle outwards, and manipulate the trim surround off the handle and door panel.

14 Push in the escutcheon behind the window regulator handle, extract the handle retaining clip and withdraw the handle from the spindle.

15 Undo the screw from the bottom of the door pull finger grip, and remove the finger grip from the panel.

16 Lift off the plastic caps and undo the two screws around the lower rear portion of the panel.

17 Using a flat tool or your fingers, release the studs securing the panel to the door by prising the panel out, or sharply pulling it out, in the vicinity of each stud. Lift the panel upwards and withdraw it from the door.

#### Refitting

18 Refitting is a reversal of removal. Locate the regulator handle retaining clip in the handle groove before fitting the handle to the door.

### 33 Rear door - removal, refitting and adjustment

The procedure for the rear door is virtually identical to that for the front door, and reference should be made to Section 22.

### 34 Rear door exterior handle - removal and refitting



#### Removal

1 Remove the rear door inner trim panel as described in Section 32.

2 Release the masking tape and carefully peel back the polythene condensation barrier as necessary for access to the door lock area.

3 Remove the access plug from the rear of the door.

4 Undo the screw securing the interior lock button control rod bellcrank.

5 Withdraw the bellcrank from the door, and disconnect the door lock control rod.

6 Undo the bolt securing the rear glass channel to the door, and remove the glass channel.

7 Undo the three screws securing the door lock to the rear face of the door.

## 11•16 Bodywork and fittings

- 8 Release the door lock control rod from the plastic guide on the inner face of the door.
- 9 Move the door lock aside, and undo the bolts securing the exterior handle to the door.
- 10 Withdraw the exterior handle, release the collar and remove the control rod from the exterior handle lever.
- 11 Remove the exterior handle from the door.

### Refitting

- 12 Refitting is a reversal of removal.

### 35 Rear door lock - removal and refitting



### Removal

- 1 Remove the rear door exterior handle as described in Section 34.
- 2 Release the door inner handle control rod from its plastic guide on the inner face of the door (see illustration).
- 3 Carefully prise out the two control rods from their respective levers on the door lock.
- 4 Disconnect the central locking motor wiring multiplug, and manipulate the lock assembly from the door.

### Refitting

- 5 Refitting is a reversal of removal.

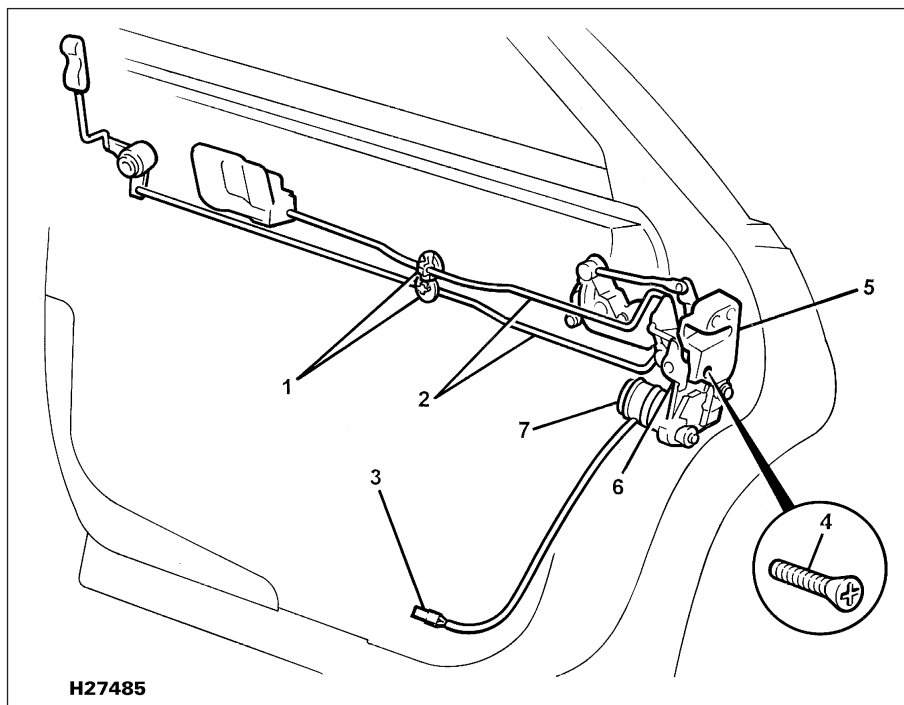

H27485

35.2 Rear door lock attachments

- |                           |                         |  |
|---------------------------|-------------------------|--|
| 1 Control rod and guide   | 4 Lock retaining screws | 6 Central locking motor retaining screws |
| 2 Control rod attachments | 5 Door lock             | 7 Central locking motor                  |
| 3 Wiring multiplug        |                         |  |

### 36 Rear door interior handle - removal and refitting

The procedure for the rear door is virtually identical to that for the front door, and reference should be made to Section 26.

### 37 Rear door window glass - removal and refitting

The procedure for the rear door is virtually identical to that for the front door, and reference should be made to Section 27.

### 38 Rear door window lift motor - removal and refitting

The procedure for the rear door is virtually identical to that for the front door, and reference should be made to Section 28.

### 39 Rear door window lift manual regulator - removal and refitting

The procedure is virtually identical to that for the front door with electric lift motor, except that the regulator is secured to the

door with two bolts, and there are no wiring multiplugs to disconnect. The complete procedure is covered in Section 28.

### 40 Rear quarter light glass (Coupe models) - removal and refitting



### Removal

- 1 Remove the rear seat cushion and squab as described in Section 43.
- 2 Carefully ease the door weatherstrip away from the door pillar in the vicinity of the lower trim panel.
- 3 Lift off the plastic caps and undo the lower trim panel retaining screw at the upper front edge of the panel. Repeat this procedure with the remaining three screws, two at the bottom and one at the upper rear of the panel.
- 4 Using a flat tool or your fingers, release the six studs securing the lower trim panel to the body by prising the panel out, or sharply pulling it out, in the vicinity of each stud. Lift away the panel.
- 5 Prise off the cap and undo the seat belt upper anchorage bolt.
- 6 Undo the three lower screws securing the upper trim panel to the body.
- 7 Using the same procedure as for the lower trim panel, release the ten panel retaining studs and remove the panel from the car.
- 8 Undo the eight nuts securing the quarter light glass in position and carefully ease the glass from the body aperture.

### Refitting

- 9 Refitting is a reversal of removal, but clean the aperture and the glass thoroughly prior to refitting.

### 41 Bumpers - removal and refitting



### Front bumper

#### Removal

- 1 Refer to Chapter 12 and remove the headlight lens units, and where fitted, the headlight washer jets.
- 2 On pre-1992 model year vehicles, remove the radiator grille as described in Section 19.
- 3 Undo the bolt and two screws securing the access panels below the front of each wheelarch. Remove both panels (see illustration).
- 4 Where fitted, disconnect the wiring multiplugs from the driving lights.
- 5 Where fitted, undo the retaining screw and move the ambient air temperature sensor to one side.
- 6 Undo the two nuts securing the bumper moulding to the frame at the front. Withdraw the washers and clamp plates.
- 7 Release the wheelarch liners from the



bumper moulding, and release the moulding from the side retaining clips.

- 8 Withdraw the moulding from the bumper.
- 9 Where fitted, release the washer pipe clips and studs, and disconnect the wiring multiplug.
- 10 On later models, prise out the two radiator baffle retaining studs.
- 11 Undo the bolt securing the dim-dip resistor bracket (where fitted).
- 12 Undo the two bolts securing the centre support member to the bumper.
- 13 Undo the two end bolts securing the bumper to the frame and remove the bumper.

**Refitting**

14 Refitting is a reversal of removal.

**Rear bumper**

**Removal**

- 15 Remove the trim from the rear of the luggage compartment.
- 16 Undo the screws and remove the two wheelarch liners (see illustration).
- 17 Withdraw the grommets from the rear face of the luggage compartment, and undo the two bumper moulding retaining nuts and washers.
- 18 Release the moulding from the side retaining clips, and withdraw the moulding from the bumper.
- 19 Where fitted, remove the plastic cover over the rear towing eye.
- 20 Withdraw the grommets, and undo the two bolts each side securing the bumper to the frame.
- 21 Remove the bumper from the car.

**Refitting**

22 Refitting is a reversal of removal.

**42 Front seats - removal and refitting**

**Removal**

- 1 Where a lumbar support switch panel is fitted to the side of the seat, carefully prise up the front of the switch panel, disconnect the wiring connectors and remove the panel.
- 2 On early models, prise off the trim caps, and undo the two screws securing the trim panel below the seat base. Remove the trim panel.
- 3 Undo the bolt securing the seat belt at the base of the seat.
- 4 Undo the four bolts securing the seat runners.
- 5 Undo the bolt securing the seat belt stalk, and remove the stalk.
- 6 Disconnect the seat control multiplugs and release the wiring harness from the cable ties.
- 7 Withdraw the seat from the car.

**Refitting**

8 Refitting is a reversal of removal. Ensure that all wiring harnesses are secured with cable ties well clear of the seat control components and runners.

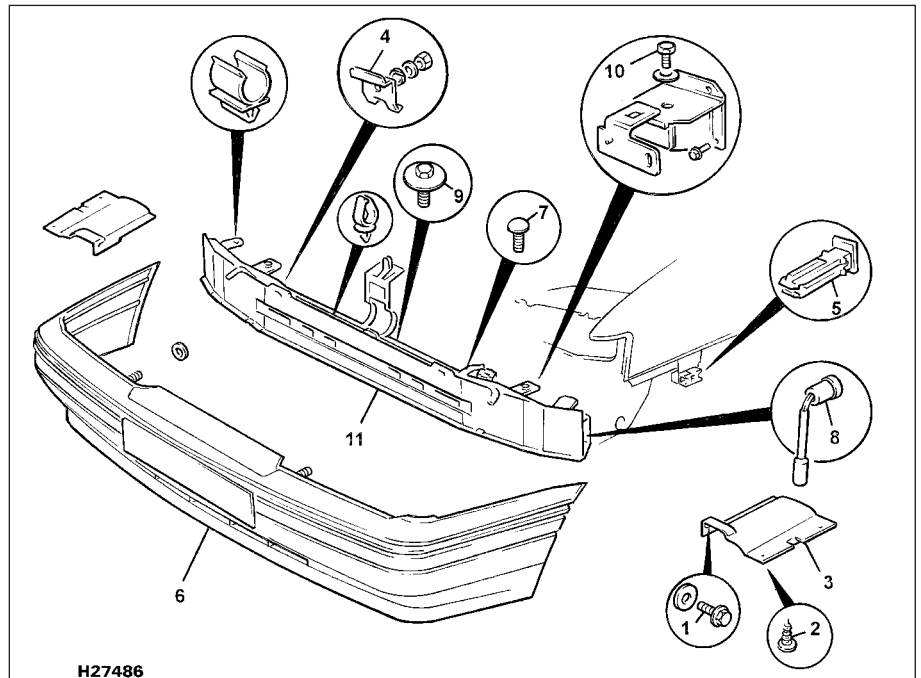

H27486

41.3 Front bumper components - early models shown, later models similar

- |                                 |                              |                               |
|---------------------------------|------------------------------|-------------------------------|
| 1 Access panel retaining bolt   | 5 Bumper moulding side clips | 9 Centre support member bolts |
| 2 Access panel retaining screws | 6 Bumper moulding            | 10 Bumper retaining bolts     |
| 3 Access panel                  | 7 Stud                       | 11 Bumper mounting            |
| 4 Bumper moulding clamp         | 8 Wiring multiplug           |                               |

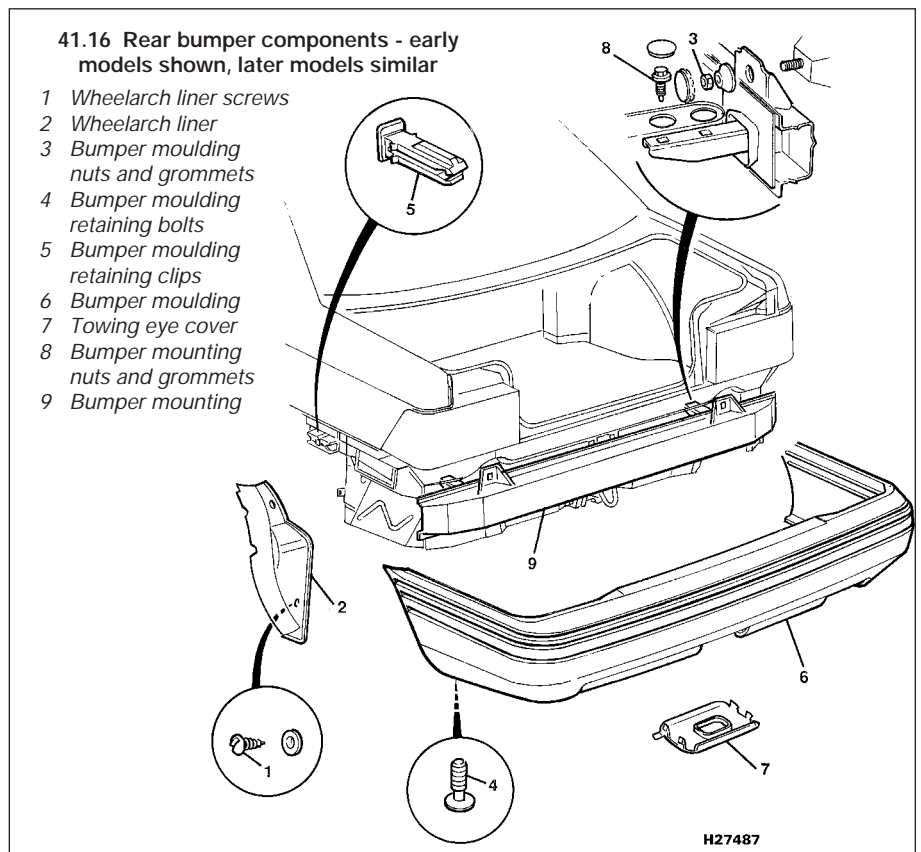

H27487

41.16 Rear bumper components - early models shown, later models similar

- 1 Wheelarch liner screws
- 2 Wheelarch liner
- 3 Bumper moulding nuts and grommets
- 4 Bumper moulding retaining bolts
- 5 Bumper moulding retaining clips
- 6 Bumper moulding
- 7 Towing eye cover
- 8 Bumper mounting nuts and grommets
- 9 Bumper mounting

### 43 Rear seats - removal and refitting



#### Saloon models

##### Removal - bench type seat (pre-1992 model year)

- 1 Push the seat base rearwards, and at the same time lift it up to release the two retainers. Remove the seat base from the car.
- 2 Undo the four bolts at the base of the seat squab.
- 3 Release the two seat belts from the retainers.
- 4 Slide the squab downwards and forwards to release the rear locating pegs, then remove the squab from the car.

##### Removal - bench type seat (1992 model year onwards)

- 5 Push the seat base rearwards, and at the same time lift it up to release the two retainers. Remove the seat base from the car.
- 6 Undo the bolt at the base of each side cushion extension, lift the cushion extensions upwards to release the rear wire retainers, and remove the side cushions.
- 7 Operate the release levers and tip the two seat squabs forward.
- 8 Undo the two bolts securing the hinge brackets at the ends of each squab.
- 9 Release the seat belt stalks and remove the squabs from the car.

##### Removal - individual type seat

- 10 Lift up the seat base to disengage the floor clips and remove the base.
- 11 Undo the four nuts securing the seat pan to the floor. Slide the pan sideways to disengage the squab guides and remove the pan.
- 12 Slide the seat squab downwards and forwards to disengage the rear upper retainers and remove the squab from the car.

##### Refitting - all seat types

- 13 Refitting is a reversal of removal.

#### Fastback models

- 14 Refer to the above procedure for the bench type seat (1992 model year onwards).

#### Coupe models

##### Removal

- 15 Push the seat base rearwards, and at the same time lift it up to release the two retainers. Remove the seat base from the car.
- 16 From inside the luggage compartment, undo the three seat squab upper retaining bolts.
- 17 Undo the four lower retaining bolts at the base of the squab.
- 18 Release the seat belt buckles from their location pockets and remove the seat squab from the car.

##### Refitting

- 19 Refitting is a reversal of removal.



44.2a Undo the release lever surround retaining screw . . .

### 44 Rear seat squab release lever and cable - removal and refitting



#### Removal

- 1 Remove the luggage compartment light from the release lever surround.
- 2 Undo the screw in the light aperture, move the release lever surround forwards and outwards, then disengage the two rear locating lugs (see illustrations).
- 3 Extract the outer cable retaining clip at the rear of the lever surround (see illustration).
- 4 Disengage the inner cable from the release lever, and remove the lever and surround assembly.
- 5 Extract the outer cable retaining clip at the squab locking mechanism (see illustration).
- 6 Disengage the inner cable from the lever, and remove the cable from the car.

#### Refitting

- 7 Refitting is a reversal of removal.

### 45 Seat belts - removal and refitting



#### Front seat belts - Saloon and Fastback models

##### Removal

- 1 Remove the front seat as described in Section 42.



44.3 Extract the outer cable retaining clip (arrowed) at the lever surround . . .



44.2b . . . and disengage the locating lugs

- 2 Remove the trim cap over the top anchorage, undo the retaining bolt and recover the spacer and fibre washer.
- 3 Ease the weatherstrip away from both sides of the centre door pillar.
- 4 Carefully prise off the upper trim from the centre door pillar.
- 5 Undo the two screws, nearest the centre door pillar, from the front and rear carpet retainer plates.
- 6 Lift the ends of the carpet retainer plates and carefully prise off the lower trim from the centre door pillar.
- 7 Undo the retaining screw from the seat belt guide and remove the guide.
- 8 Undo the bolt at the seat belt anchorage.
- 9 Undo the bolt at the base of the inertia reel, and remove the seat belt components.
- 10 Undo the bolt securing the seat belt stalk to the seat, and remove the stalk.

##### Refitting

- 11 Refitting is a reversal of removal.

#### Front seat belts - Coupe models

##### Removal

- 12 Remove the front seat as described in Section 42.
- 13 Remove the trim cap over the top anchorage, undo the retaining bolt and recover the spacer and fibre washer.
- 14 Carefully ease the door weatherstrip away from the door pillar in the vicinity of the lower trim panel.
- 15 Lift off the plastic caps and undo the lower trim panel retaining screw at the upper



44.5 . . . and the clip at the locking mechanism (arrowed)



47.3 Prise up the coin trays

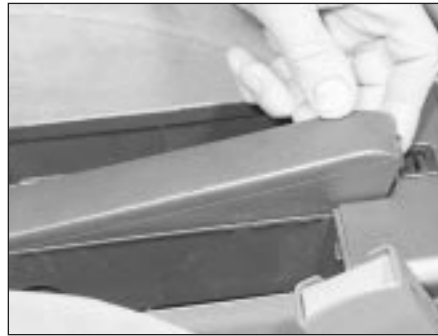

47.4 Prise up the handbrake lever cover trim



47.5 Console left-hand retaining bolt (arrowed)

front edge of the panel. Repeat this procedure with the remaining three screws, two at the bottom and one at the upper rear of the panel.

16 Using a flat tool or your fingers, release the six studs securing the lower trim panel to the body by prising the panel out, or sharply pulling it out, in the vicinity of each stud. Lift away the panel.

17 Lift off the plastic caps and undo the two bolts securing the seat belt lower anchorage bar to the body. Release the bar and slide out the seat belt.

18 Release the seat belt from the guide in the door pillar.

19 Undo the bolts at the base of the inertia reel, and remove the seat belt components.

20 Undo the bolt securing the seat belt stalk to the seat, and remove the stalk.

**Refitting**

21 Refitting is a reversal of removal.

**Rear seat belts**

**Removal**

22 Remove the rear seat base and squab as described in Section 43.

23 Undo the bolts at the seat belt lower anchorages.

24 Remove the belt guide from the rear parcel shelf.

25 Remove the trim cap over the top anchorage (early models), undo the retaining bolt and recover the spacer and fibre washer.

26 From within the luggage compartment, undo the bolt at the base of the inertia reel,

and remove the seat belt assembly from the luggage compartment. On later Saloon models it will be necessary to remove the rear parcel shelf for access to the inertia reel.

27 Undo the retaining bolts and remove the individual static belts as required.

**Refitting**

28 Refitting is a reversal of removal.

**46 Sunroof - general information**

A mechanically or electrically operated steel sunroof is available as standard or optional equipment according to model.

The sunroof is maintenance-free, but any adjustment or removal and refitting of the component parts should be entrusted to a dealer, due to the complexity of the unit and the need to remove much of the interior trim and headlining to gain access. The latter operation is involved, and requires care and specialist knowledge to avoid damage.

**47 Centre console - removal and refitting**

**Removal**

1 On manual transmission models, unscrew the gear lever knob and remove the gear lever boot.

2 On automatic transmission models, undo the retaining screw and lift off the selector lever. Carefully prise up the selector lever quadrant, disconnect the wiring multiplugs and remove the quadrant.

3 Prise up the coin trays or switch panels on each side of the handbrake lever (see illustration). Remove the coin trays, or disconnect the multiplugs and remove the switch panels.

4 Insert a screwdriver under the rear end of the cover trim over the handbrake lever. Prise up the cover rear end, then withdraw the cover from the handbrake lever (see illustration).

5 Lift back the edges of the carpet under the coin holder or switch panel locations, and undo the two console retaining bolts under the carpet (see illustration).

6 Remove the rear ashtray, followed by the ashtray insert (where fitted). Disconnect the ashtray wiring multiplugs and remove the ashtray (see illustration).

7 Undo the two screws securing the rear of the console, in the ashtray aperture (see illustration).

8 Where applicable, prise off the plastic caps and undo the two screws at the extreme forward sides of the console, beneath the fascia.

9 On models with a high console, open the cassette holder lid, and undo the two screws at the base of the cassette racks (see illustration).

10 Where a switch panel or removable cover



47.6 Remove the rear ashtray and insert . . .



47.7 . . . and undo the two rear screws

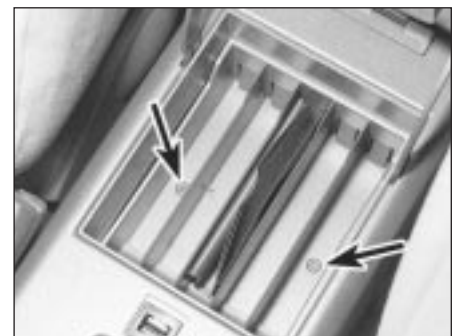

47.9 Undo the two screws at the base of the cassette rack





47.11a Apply the handbrake fully . . .



47.11b . . . and lift the console over the handbrake lever



48.2 Remove the trim panel under the fascia

plate is fitted just forward of the handbrake lever, release the panel or cover plate, disconnect the wiring multiplugs (where applicable) and manipulate the panel or cover plate over the handbrake lever.

11 Apply the handbrake as hard as possible, then lift the rear of the console over the handbrake lever (see illustrations). Slide the forward end of the console out from under the fascia and remove the console from the car. On some models, there is barely sufficient clearance to allow the console to clear the handbrake under normal conditions, and if it proves impossible to do this, refer to Chapter 9 and slacken the handbrake adjuster to allow the lever to be pulled up further.

**Refitting**

12 Refitting is a reversal of removal. Adjust

the handbrake as described in Chapter 9, if the adjuster position was disturbed.

**48 Facia - removal and refitting**



**Pre-1992 model year**

**Removal**

- 1 Remove the instrument panel and the radio cassette player as described in Chapter 12.
- 2 Release the turnbuckles and remove the trim panel under the fascia on the driver's side. Remove the additional panel over the clutch, brake and accelerator pedals (see illustration).
- 3 Release the heater outer cable retaining

clips on the lower right-hand side of the heater, and slip the inner cable ends off the lever studs (see illustration).

- 4 Pull off the control knobs on the heater control switches (see illustration).
- 5 Undo the two nuts and two bolts securing the steering column clamp and mounting bracket under the fascia. Remove the clamp and lower the column.
- 6 Release the retaining button and withdraw the triangular-shaped trim panels at the base of the lower facia (see illustration).
- 7 Undo the retaining screw now exposed on each side, securing the lower facia side braces to the support bracket (see illustration).
- 8 Using a screwdriver, release the radio mounting plate side retainers and remove the mounting plate (see illustrations).



48.3 Release the heater cables at the heater (arrowed)



48.4 Pull off the heater knobs



48.6 Withdraw the trim panel at the base of the lower facia



48.7 Undo the side brace retaining screws (arrowed)



48.8a Release the radio mounting plate retainers (arrowed) . . .



48.8b . . . and remove the mounting plate



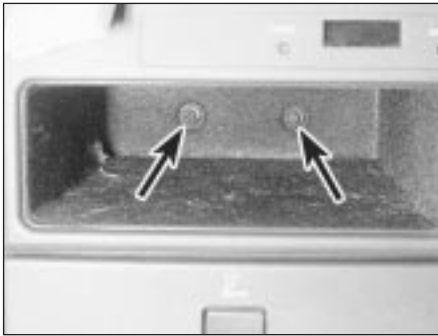

48.9 Undo the screws in the oddments tray

9 Undo the two screws at the base of the oddments tray below the clock (see illustration).

10 Withdraw the clock and oddments tray housing from the lower fascia, and disconnect the clock wiring multiplug.

11 Undo the two upper screws securing the lower fascia, and withdraw the lower fascia from its location (see illustrations).

12 Disconnect the wiring multiplug at the rear and remove the lower fascia from the car.

13 Undo the screw at each end of the cross-brace under the fascia on the driver's side (see illustration).

14 Undo the bolt at each lower end of the fascia (see illustration).

15 Undo the two bolts on the front support plate at the base of the fascia (see illustration).



48.11a Undo the lower fascia upper screws . . .

16 Lift up the cover plate on the fascia top, at the centre below the windscreen, and undo the bolt below the plate (see illustration).

17 Prise out the trim caps at each side of the fascia, adjacent to the door apertures and undo the bolt behind (see illustrations).

18 With the help of an assistant, lift the fascia from its location and withdraw it slightly forward.

19 Disconnect the wiring multiplug at the inertia switch, and at the fusebox, and disconnect the two main loom multiplugs.

20 With all the wiring disconnected, remove the fascia from the car.

#### Refitting

21 Refitting is a reversal of removal. When connecting the heater cables, adjust the position of the outer cables in their retaining



48.11b . . . and remove the lower fascia

clips so as to give full travel of the heater levers, consistent with full travel of the control levers.

#### 1992 model year onwards



**Warning:** On vehicles fitted with a passenger's side air bag, seek the advice of a Rover dealer concerning safety implications before proceeding.

#### Removal

22 Where fitted, have the passenger side air-bag module removed by a Rover dealer, or seek his advise concerning the feasibility of the following operations before proceeding.

23 Remove the steering wheel and steering column as described in Chapter 10.

24 Remove the instrument panel, the radio



48.13 Undo the cross-brace screws



48.14 Undo the bolt at the fascia lower end

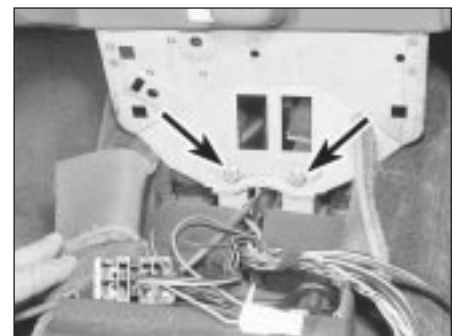

48.15 Undo the front support plate bolts (arrowed)



48.16 Lift up the centre cover plate and undo the bolt below the plate



48.17a Prise out the trim caps . . .



48.17b . . . and undo the bolts in the door apertures

## 11•22 Bodywork and fittings

---

cassette player and the clock as described in Chapter 12.

**25** Release the two turnbuckles and remove the lower trim panel under the fascia on the passenger's side.

**26** Undo the two, or four bolts, as applicable below the glovebox and remove the glovebox from the fascia.

**27** Pull off the weatherstrip from the front body pillars around the fascia and footwell.

**28** Undo the two screws each side and single retaining stud on the left-hand side, and remove the two footwell trim panels.

**29** Remove the radio cassette player mounting housing.

**30** Remove the fusebox cover under the fascia on the driver's side if not already done.

**31** From within the clock aperture, undo the ashtray securing screw, disconnect the wiring connectors and remove the ashtray.

**32** Release the retaining button and withdraw

the triangular-shaped trim panels at the base of the lower fascia.

**33** Undo the four upper screws and two inner screws securing the lower fascia to the upper fascia. Remove the lower fascia.

**34** Prise out the trim caps at each side of the fascia, adjacent to the door apertures and undo the bolt behind.

**35** Undo the two bolts on the front support plate at the base of the fascia.

**36** Lift up the cover plate or light sensor panel on the fascia top, at the centre below the windscreen, and undo the bolt behind.

**37** Undo the two bolts securing the fascia mounting brackets to the body.

**38** Where fitted, undo the additional securing bolt behind the glovebox aperture.

**39** Disconnect the wiring multiplugs at the fusebox, noting their locations.

**40** Disconnect the two main wiring harness multiplugs.

**41** Where fitted, disconnect the two air conditioning wiring harness multiplugs.

**42** Detach the relay from the fascia rail above the pedals on the driver's side.

**43** Disconnect any remaining wiring multiplugs, noting their locations.

**44** Where applicable, release the heater outer cable retaining clips on the lower right-hand side of the heater, and slip the inner cable ends off the lever studs.

**45** With all the wiring disconnected, remove the fascia from the car.

### Refitting





**46** Refitting is a reversal of removal. When connecting the heater cables, adjust the position of the outer cables in their retaining clips so as to give full travel of the heater levers, consistent with full travel of the control levers.

# Chapter 12 Body electrical system

## Contents

Airbag supplementary restraint system - general information . . . . .	26	Headlight beam alignment - checking and adjustment . . . . .	8
Aerial amplifier - removal and refitting . . . . .	22	Horn - removal and refitting . . . . .	14
Anti-theft system - general information . . . . .	24	Instrument panel - removal and refitting . . . . .	9
Anti-theft system components - removal and refitting . . . . .	25	Instrument panel components - removal and refitting . . . . .	10
Battery - removal and refitting . . . . . See Chapter 5		Power amplifier - removal and refitting . . . . .	23
Battery check, maintenance and charging . . . . . See Chapter 1		Radio/cassette player - removal and refitting . . . . .	19
Bulbs (exterior lights) - renewal . . . . .	5	Speakers - removal and refitting . . . . .	21
Bulbs (interior lights) - renewal . . . . .	6	Switches - removal and refitting . . . . .	4
Central control unit - description, removal and refitting . . . . .	11	Tailgate wiper motor and linkage - removal and refitting . . . . .	17
Clock - removal and refitting . . . . .	12	Trip computer - removal and refitting . . . . .	13
Compact disc player - removal and refitting . . . . .	20	Windscreen/tailgate and headlight washer system and wiper blade check . . . . . See Chapter 1	
Electrical fault finding - general information . . . . .	2	Windscreen/tailgate/headlight washer system components - removal and refitting . . . . .	18
Electrical system check . . . . . See Chapter 1		Windscreen wiper motor and linkage - removal and refitting . . . . .	16
Exterior light units - removal and refitting . . . . .	7	Wiper arms - removal and refitting . . . . .	15
Fuses and relays - general information . . . . .	3		
General information and precautions . . . . .	1		

## Degrees of difficulty

<b>Easy</b> , suitable for novice with little experience 	<b>Fairly easy</b> , suitable for beginner with some experience 	<b>Fairly difficult</b> , suitable for competent DIY mechanic 	<b>Difficult</b> , suitable for experienced DIY mechanic 	<b>Very difficult</b> , suitable for expert DIY or professional 
---	--	--	---	--

## Specifications

Bulbs	Wattage
Headlight dipped beam . . . . .	60/55
Headlight main beam . . . . .	55
Sidelights . . . . .	5
Direction indicators . . . . .	21
Side repeater lights . . . . .	5
Front fog light . . . . .	55
Stop/tail lights . . . . .	21/5
Reversing lights . . . . .	21
Rear fog light . . . . .	21
Number plate light . . . . .	5
Engine compartment light . . . . .	5
Interior courtesy lights . . . . .	5 or 10
Map reading and courtesy light . . . . .	4
Footwell and glovebox lights . . . . .	3 or 5
Vanity mirror light . . . . .	3
Luggage compartment light . . . . .	10
Instrument panel illumination and warning lights . . . . .	1.2
Ignition warning light . . . . .	2
Switch illumination bulbs . . . . .	0.36
Heater control illumination bulbs . . . . .	0.36 and 1.2

## 1 General information and precautions

### General information

The electrical system is of 12-volt negative earth type. Power for the lights and all electrical accessories is supplied by a lead/acid battery which is charged by the alternator.

This Chapter covers repair and service procedures for the various electrical components and systems not associated with the engine. Information on the battery, ignition system, alternator, and starter motor can be found in Chapter 5.

### Precautions



**Warning:** Before carrying out any work on the electrical system, read through the precautions given in "Safety first!" at the beginning of this manual and in Chapter 5.

**Caution:** Prior to working on any component in the electrical system, the battery negative lead should first be disconnected, to prevent the possibility of electrical short-circuits and/or fires.

Disconnection of the battery will, however, erase the audio unit anti-theft security code and also erase the memories of many of the electrical system electronic control units. Refer to Chapter 5, Section 1 for additional information on the effects of battery disconnection.

## 2 Electrical fault finding - general information



**Note:** Refer to the precautions given in "Safety first!" and in Section 1 of this Chapter before starting work. The following tests relate to testing of the main electrical circuits, and should not be used to test delicate electronic circuits (such as engine management systems, anti-lock braking systems, etc), particularly where an electronic control module is used. Also refer to the precautions given in Chapter 5, Section 1.

### General

1 A typical electrical circuit consists of an electrical component, any switches, relays, motors, fuses, fusible links or circuit breakers related to that component, and the wiring and connectors which link the component to both the battery and the chassis. To help to pinpoint a problem in an electrical circuit, wiring diagrams are included at the end of this manual.

2 Before attempting to diagnose an electrical fault, first study the appropriate wiring diagram, to obtain a complete understanding of the

components included in the particular circuit concerned. The possible sources of a fault can be narrowed down by noting if other components related to the circuit are operating properly. If several components or circuits fail at one time, the problem is likely to be related to a shared fuse or earth connection.

3 Electrical problems usually stem from simple causes, such as loose or corroded connections, a faulty earth connection, a blown fuse, a melted fusible link, or a faulty relay. Visually inspect the condition of all fuses, wires and connections in a problem circuit before testing the components. Use the wiring diagrams to determine which terminal connections will need to be checked in order to pinpoint the trouble-spot.

4 The basic tools required for electrical fault-finding include a circuit tester or voltmeter (a 12-volt bulb with a set of test leads can also be used for certain tests); an ohmmeter (to measure resistance and check for continuity); a battery and set of test leads; and a jumper wire, preferably with a circuit breaker or fuse incorporated, which can be used to bypass suspect wires or electrical components. Before attempting to locate a problem with test instruments, use the wiring diagram to determine where to make the connections.

5 To find the source of an intermittent wiring fault (usually due to a poor or dirty connection, or damaged wiring insulation), a "wiggle" test can be performed on the wiring. This involves wiggling the wiring by hand to see if the fault occurs as the wiring is moved. It should be possible to narrow down the source of the fault to a particular section of wiring. This method of testing can be used in conjunction with any of the tests described in the following sub-Sections.

6 Apart from problems due to poor connections, two basic types of fault can occur in an electrical circuit - open-circuit, or short-circuit.

7 Open-circuit faults are caused by a break somewhere in the circuit, which prevents current from flowing. An open-circuit fault will prevent a component from working.

8 Short-circuit faults are caused by a "short" somewhere in the circuit, which allows the current flowing in the circuit to "escape" along an alternative route, usually to earth. Short-circuit faults are normally caused by a breakdown in wiring insulation, which allows a feed wire to touch either another wire, or an earthed component such as the bodyshell. A short-circuit fault will normally cause the relevant circuit fuse to blow.

### Finding an open-circuit

9 To check for an open-circuit, connect one lead of a circuit tester or the negative lead of a voltmeter either to the battery negative terminal or to a known good earth.

10 Connect the other lead to a connector in the circuit being tested, preferably nearest to the battery or fuse. At this point, battery voltage should be present, unless the lead

from the battery or the fuse itself is faulty (bearing in mind that some circuits are live only when the ignition switch is moved to a particular position).

11 Switch on the circuit, then connect the tester lead to the connector nearest the circuit switch on the component side.

12 If voltage is present (indicated either by the tester bulb lighting or a voltmeter reading, as applicable), this means that the section of the circuit between the relevant connector and the switch is problem-free.

13 Continue to check the remainder of the circuit in the same fashion.

14 When a point is reached at which no voltage is present, the problem must lie between that point and the previous test point with voltage. Most problems can be traced to a broken, corroded or loose connection.

### Finding a short-circuit

15 To check for a short-circuit, first disconnect the load(s) from the circuit (loads are the components which draw current from a circuit, such as bulbs, motors, heating elements, etc).

16 Remove the relevant fuse from the circuit, and connect a circuit tester or voltmeter to the fuse connections.

17 Switch on the circuit, bearing in mind that some circuits are live only when the ignition switch is moved to a particular position.

18 If voltage is present (indicated either by the test bulb lighting or a voltmeter reading, as applicable), this means that there is a short-circuit.

19 If no voltage is present during this test, but the fuse still blows with the load(s) reconnected, this indicates an internal fault in the load(s).

### Finding an earth fault

20 The battery negative terminal is connected to "earth" - the metal of the engine/transmission unit and the vehicle body - and many systems are wired so that they only receive a positive feed, the current returning via the metal of the car body. This means that the component mounting and the body form part of that circuit. Loose or corroded mountings can therefore cause a range of electrical faults, ranging from total failure of a circuit, to a puzzling partial failure. In particular, lights may shine dimly (especially when another circuit sharing the same earth point is in operation), motors (eg wiper motors or the radiator cooling fan motor) may run slowly, and the operation of one circuit may have an apparently-unrelated effect on another. Note that on many vehicles, earth straps are used between certain components, such as the engine/transmission and the body, usually where there is no metal-to-metal contact between components, due to flexible rubber mountings, etc.

21 To check whether a component is properly earthed, disconnect the battery (refer to Chapter 5, Section 1) and connect one lead of an ohmmeter to a known good earth point. Connect the other lead to the wire or earth





3.2a Lift away the trim panel for access to the fusebox . . .



3.2b . . . noting the fuse identification on the rear of the panel

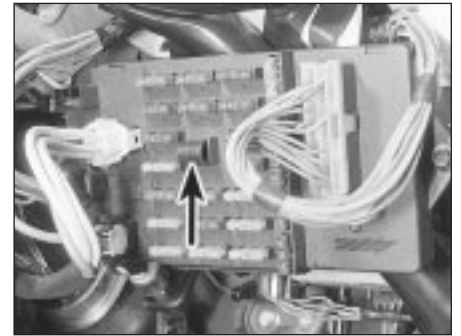

3.3a Use the fuse removal tool (arrowed) . . .

connection being tested. The resistance reading should be zero; if not, check the connection as follows.

**22** If an earth connection is thought to be faulty, dismantle the connection, and clean both the bodyshell and the wire terminal (or the component earth connection mating surface) back to bare metal. Be careful to remove all traces of dirt and corrosion, then use a knife to trim away any paint, so that a clean metal-to-metal joint is made. On reassembly, tighten the joint fasteners securely; if a wire terminal is being refitted, use serrated washers between the terminal and the bodyshell, to ensure a clean and secure connection. When the connection is remade, prevent the onset of corrosion in the future by applying a coat of petroleum jelly or silicone-based grease, or by spraying on (at regular intervals) a proprietary ignition sealer.

### 3 Fuses and relays - general information



**Note:** It is important to note that the ignition switch and the appropriate electrical circuit must always be switched off before any of the fuses (or relays) are removed and renewed. In the event of the fuse/relay unit having to be removed. When disconnecting the battery, reference should be made to Chapter 5, Section 1.

#### General

**1** Two or three fuseboxes are used on Rover 800 models. One is located inside the car

under the facia on the driver's side with an auxiliary fusebox alongside it, another is located on the left-hand side of the engine compartment and, on later models, a third is located in the luggage compartment on the left-hand side. The main vehicle system relays are located on a relay panel behind the interior fusebox, and also in the engine compartment fuse and relay box. Additional relays are located in various locations according to model and equipment fitted.

#### Interior fusebox

**2** To gain access to the fuses, release the turnbuckles at the base of the trim panel beneath the steering column, and lift away the panel. The fuse locations, current rating and circuits protected are shown on a label attached to the inside of the panel. Each fuse is also colour-coded, and has its rating stamped on it (see illustrations).

**3** To remove a fuse from its location, withdraw the removal tool from the fusebox, push the tool over the fuse to be removed and pull out the fuse (see illustrations). Refit the fuse by pressing it firmly into position. Spare fuses are located in a vertical row on the right-hand side of the fusebox, or in marked vacant spaces.

**4** Always renew the fuse with one of an identical rating. Never renew a fuse more than once without finding the source of the trouble.

**5** To gain access to the relays behind the fusebox, undo the two fusebox retaining bolts, one at each end, and ease the unit away from its location. For greater access, mark the various wiring multiplugs to avoid

confusion when refitting, then disconnect them and remove the fusebox completely.

**6** The relays can be removed by simply pulling them from their respective locations. If a system controlled by a relay becomes inoperative, and the relay is suspect, operate the system and if the relay is functioning it should be possible to hear it click as it is energised. If this is the case, the fault lies with the components of the system. If the relay is not being energised, then the relay is either not receiving a main supply voltage, a switching voltage, or the relay itself is faulty.

#### Engine compartment fuse and relay box

**7** The engine compartment fuse and relay box contains additional fuses, some vehicle system relays, and the main wiring loom fusible links.

**8** To gain access, press the upper edge of the retaining catch on the fuse and relay box cover, lift the cover at the front and disengage the rear tags (see illustration). A symbol identifying the function of each fuse is marked on the cover.

**9** The fuses and relays can be renewed in the same way as for the interior fusebox described previously. The fuse removal tool, together with the spare fuses, is located at the front of the box. On certain models, additional fuses and relays are located on the outside edge of the box, with the fuses under a protective cover. Lift off the cover to renew each individual fuse (see illustration).



3.3b . . . to withdraw the fuses from their locations



3.8 Removing the engine compartment fuse and relay box cover



3.9 Additional fuse located under a cover on the outside of the fuse and relay box



3.10 Lift off the protective cover for access to the fusible links



3.11 Luggage compartment fusebox (arrowed) located behind the left-hand side interior trim panel



4.3a Undo the three lower screws . . .

10 To gain access to the wiring loom fusible links, lift off the protective cover on the right-hand side of the fuse and relay box (see illustration). A blown fusible link indicates a serious wiring or system fault, which must be diagnosed before renewing the link.

### Luggage compartment fusebox

11 On later models an additional fusebox is located in the luggage compartment either behind the left-hand rear light cluster or behind the left-hand side interior trim panel (see illustration).

12 To gain access to the rear fusebox, either remove the protective cover at the rear of the light cluster, or release the trim panel on the side of the luggage compartment. Fuse

renewal is the same as described previously for the other fuseboxes.

## 4 Switches - removal and refitting



**Note:** Disconnect the battery negative (earth) lead before removing any switch and reconnect the lead after refitting the switch (refer to Chapter 5, Section 1).

### Ignition switch/steering column lock

1 The ignition switch is an integral part of the steering column lock, and reference should be made to Chapter 10.

### Steering column switches

#### Pre-1992 model year

2 Remove the steering wheel as described in Chapter 10.

3 Undo the three lower screws and the single upper screw, and remove the upper and lower steering column shrouds (see illustrations).

4 Release the fibre optic lead from the bulbholder by carefully prising up the plastic tag (see illustration).

5 Depress the retainers at the top and bottom of the switch, then pull the switch out of the steering column boss (see illustrations).

6 Disconnect the wiring multiplug and remove the switch from the car.

7 The switch on the other side of the column is removed in the same way.

8 Refitting is a reversal of removal.

#### 1992 model year onwards

9 Remove the steering wheel as described in Chapter 10.

10 Undo the three lower screws, and remove the upper and lower steering column shrouds (see illustration).

11 Release the turnbuckles and lower the fusebox cover at the base of the steering column.

12 On models without cruise control or airbag supplementary restraint system, remove the slip ring from the centre of the switch assembly.

13 On models with cruise control, and/or



4.3b . . . and single upper screw . . .



4.3c . . . then lift off the steering column shrouds



4.4 Release the fibre optic lead from the bulbholder



4.5a Depress the top and bottom switch retainers . . .



4.5b . . . and remove the switch

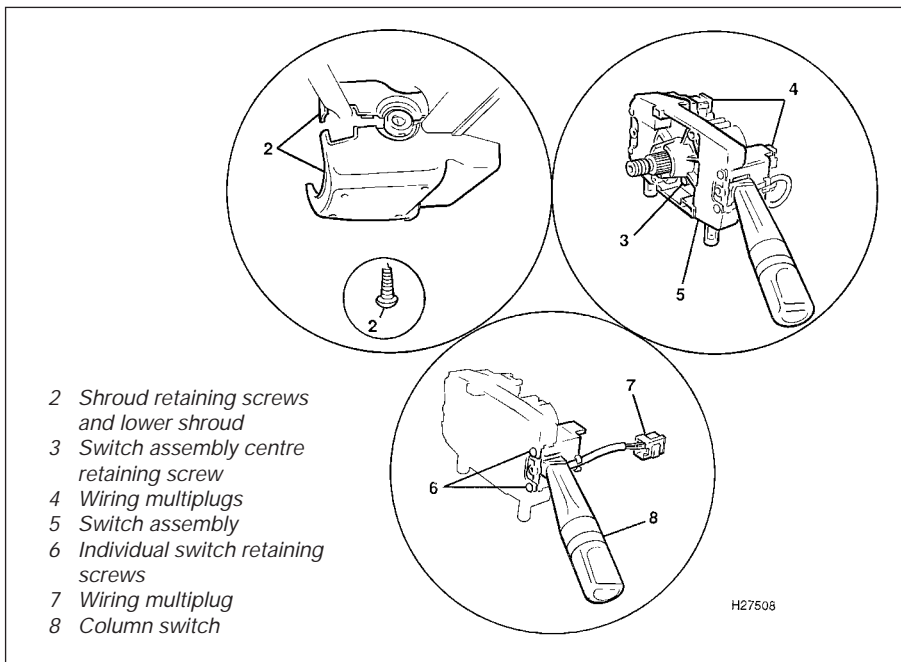

- 2 Shroud retaining screws and lower shroud
- 3 Switch assembly centre retaining screw
- 4 Wiring multiplugs
- 5 Switch assembly
- 6 Individual switch retaining screws
- 7 Wiring multiplug
- 8 Column switch

4.10 Steering column switch details on later models

airbag supplementary restraint system, remove the rotary coupler as described in Chapter 10.

14 Slacken the retaining screw in the front centre of the switch assembly.

15 Disconnect the four wiring multiplugs at the rear, then withdraw the switch assembly from the steering column.

16 Undo the two screws securing the individual switch to the main assembly.

17 Disconnect the wiring multiplug at the rear and withdraw the switch from the main assembly. Use a thin flat blade to release the switch from its location as it is withdrawn.

18 The switch on the other side of the column is removed in the same way.

19 Refitting is a reversal of removal. Refer to Chapter 10 when refitting the rotary coupler and steering wheel.

**Centre console switches**

20 Carefully prise up the coin holder or switch panel as applicable from the side of the centre console.



4.27 Courtesy light door pillar switch location

21 If individual switches are fitted, disconnect the wiring multiplug, depress the lugs on the side of the switch and withdraw the switch from the coin holder panel (see illustration).

22 If a multi-switch pack is fitted, disconnect the wiring multiplug and remove the switch panel complete.

23 Refitting is a reversal of removal.

**Door switches**

24 Remove the front or rear door inner trim panel as described in Chapter 11.



4.21 Centre console switch removal

25 Release the switch pack assemblies from the rear of the trim panel and withdraw them. Note that the individual switches in the switch packs cannot be removed separately. If any are faulty, or if renewal of a switch is necessary, the complete switch pack must be obtained.

26 Refitting is a reversal of removal.

**Courtesy light door pillar switches**

27 Undo the retaining screw and withdraw the switch from the door pillar (see illustration).

28 Disconnect the wiring and remove the switch. Tie the wiring to the door striker plate while the switch is removed to prevent the wires dropping into the pillar.

29 Refitting is a reversal of removal.

**Instrument cowl switch units**

30 Carefully prise out the rear of the cover plate at the extreme left-hand side of the cowl and push the plate forward to release the front clips (see illustration). Undo the screw behind the plate, now exposed.

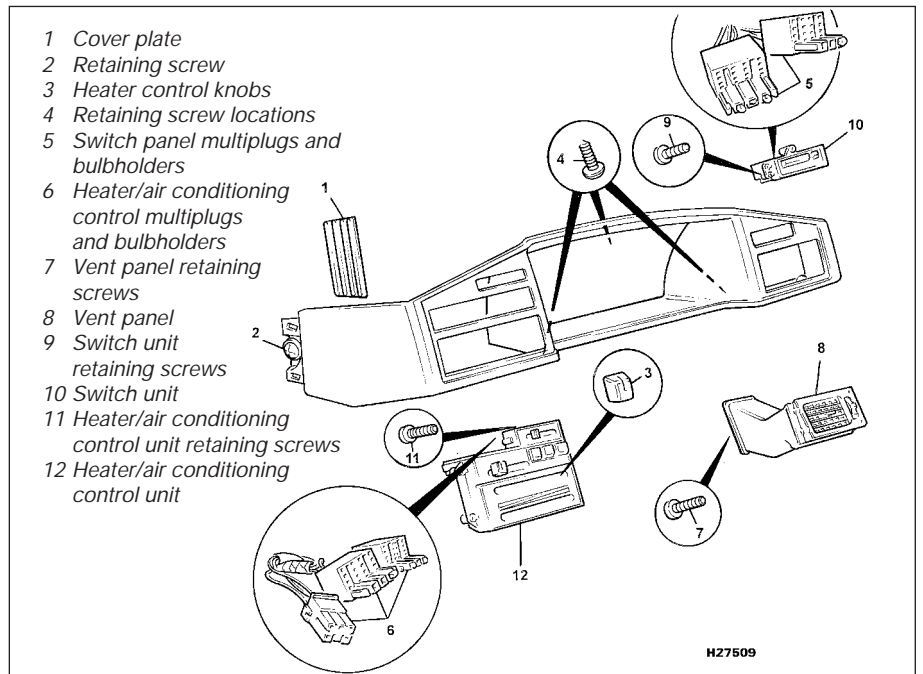

4.30 Exploded view of the instrument cowl switch units



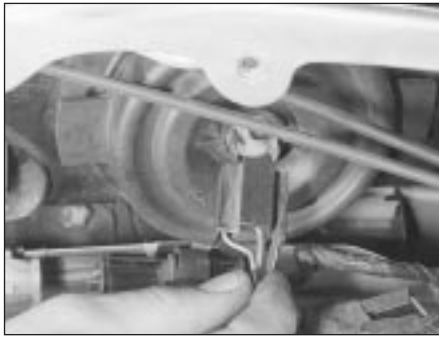

5.1 Disconnect the headlight dipped beam bulb multiplug



5.2 Release the wire clip and withdraw the bulb from the headlight unit

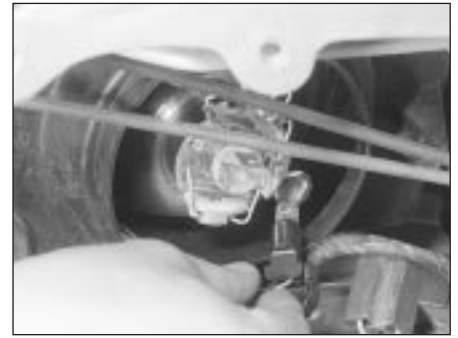

5.6 Withdraw the sidelight bulbholder from the headlight unit

- 31 Pull off the knobs on the heater controls.
- 32 Undo the three screws securing the cowl to the fascia above the instrument panel.
- 33 Undo the two screws below the vent panel on the driver's side and the two screws below the heater/air conditioning control panel.
- 34 Release the clips at the top, at each end, ease the cowl away from the fascia slightly, and disconnect the switch panel and heater control/air conditioning wiring multiplugs.
- 35 Remove the cowl from the car.
- 36 Undo the four screws and remove the driver's vent panel.
- 37 Undo the three screws and remove the switch unit.
- 38 Undo the four screws and remove the heater and air conditioning control unit.
- 39 Refitting is a reversal of removal.

**Lower fascia switches**

- 40 Refer to Section 12 for removal of the switches on the clock console.

**5 Bulbs (exterior lights) - renewal**

**Note:** Ensure that all exterior lights are switched off before disconnecting the wiring connectors to any exterior light bulbs.

**Headlight dipped beam bulb**

**Note:** On 1992 model year onwards vehicles,

remove the headlight lens unit first, as described in Section 7, for access to the bulb.

- 1 From within the engine compartment, disconnect the wiring multiplug at the rear of the headlight bulb, then pull off the rubber cover (see illustration).
- 2 Release the wire retaining clip and withdraw the bulb from its location in the headlight lens unit (see illustration). Take care not to touch the bulb glass with your fingers; if touched, clean the bulb with methylated spirit.
- 3 Fit the bulb, ensuring that the lugs in the bulb engage with the slots in the lens unit.
- 4 Refit the retaining clip, rubber cover and wiring plug. Ensure that the tab marked TOP on the cover is uppermost.

**Sidelight bulb**

**Note:** On 1992 model year onwards vehicles, remove the headlight lens unit first, as described in Section 7, for access to the bulb.

- 5 From within the engine compartment, disconnect the wiring multiplug at the rear of the headlight bulb, then pull off the rubber cover.
- 6 Withdraw the sidelight bulbholder from the headlight lens unit and remove the bulb from the holder (see illustration).
- 7 Fit a new bulb to the holder and fit the holder to the lens unit.
- 8 Refit the rubber cover and headlight wiring plug. Ensure that the tab marked TOP on the cover is uppermost.

**Headlight main beam bulb**

**Note:** On 1992 model year onwards vehicles, remove the headlight lens unit first, as described in Section 7, for access to the bulb.

- 9 Withdraw the plastic cover, release the wire clip and withdraw the bulb from the headlight lens unit (see illustration). Take care not to touch the bulb glass with your fingers; if touched, clean the bulb with methylated spirit.
- 10 Disconnect the wiring connectors and remove the bulb.
- 11 Connect the wiring to the new bulb and place the bulb in the light unit, ensuring that the flange cut-out locates in the housing ridge.
- 12 Refit the wire clip and the plastic cover.

**Front direction indicator bulb**

13 From within the engine compartment, unhook the retaining spring and withdraw the lens unit and seal from the wing (see illustration).

14 Press and turn the bulbholder anti-clockwise to remove it from the lens unit; remove the bulb from the holder in the same way (see illustration).

15 Refit the bulb and holder, locate the lens unit in position and secure with the retaining spring.

**Direction indicator side repeater bulb**

16 Press the light unit to the right, free the left-hand retainer and withdraw the unit from the front wing.



5.9 Withdraw the main beam bulb from the headlight unit



5.13 Unhook the direction indicator lens retaining spring



5.14 Withdraw the lens assembly and remove the bulbholder





5.25 Press the retainer on the access panel and remove the panel



5.26a Lift the top retainer on the bulb panel, press the two bottom retainers and withdraw the panel



5.26b On the alternative bulb panel, press the top and bottom retainers together and remove the panel

17 Turn the bulbholder anti-clockwise to remove it from the light unit, then remove the push-fit bulb from the holder.

18 Fit a new bulb, refit the bulbholder, and push the light unit into position in the wing.

### Front fog light bulb

19 Undo the two upper screws and remove the light unit surround.

20 Disconnect the wiring multiplug and remove the light unit from the front bumper assembly

21 Release the rubber cover at the base of the light unit and disconnect the wiring at the connector.

22 Release the retaining spring clip and withdraw the bulb and holder.

23 Fit a new bulb then refit the components.

### Rear light cluster bulbs

#### Rear wing light cluster

24 From within the luggage compartment, release the trim covering (where fitted) for access to the light cluster.

25 On early models, press the retainer on the access panel and remove the panel (see illustration).

26 Lift the top retainer on the bulb panel, press the two bottom retainers and withdraw the panel (see illustration). On the later type bulb panel, press the top and bottom retainers together and remove the panel (see illustration).

27 Remove the bulbs as required by

depressing and turning anti-clockwise (see illustration).

28 Fit the new bulb(s), push the bulb panel into position and refit the access panel and/or trim panel.

#### Boot lid/tailgate light cluster

29 On Saloon and Coupe models, unscrew the plastic fasteners to release the boot lid trim lining. On Fastback models, remove the plastic cover.

30 Squeeze the plastic lever and withdraw the bulbholder.

31 Remove the bulbs as required by depressing and turning anti-clockwise.

32 Fit the new bulb(s), push the bulbholder into position and refit the lining or cover.

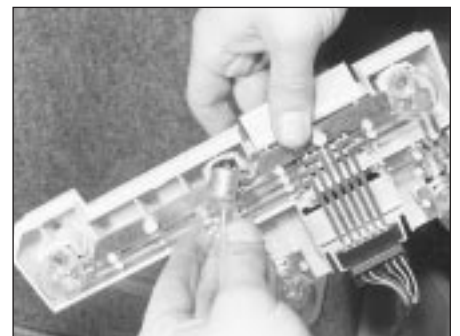

5.27 Rear light cluster bulb renewal

38 Remove the push-fit bulb from the holder.

39 Fit the new bulb and refit the bulbholder and trim.

#### All models - 1992 model year onwards

40 Undo the two screws and withdraw the number plate light unit from its location (see illustration).

41 Squeeze the two plastic tags together and release the bulbholder from the light unit (see illustration).

42 Remove the festoon bulb from the holder.

43 Fit the new bulb and refit the bulbholder and light unit.

### Engine compartment light bulb

44 Open the bonnet, undo the two retaining screws and remove the light lens.



5.33 Number plate light bulbholder on early Saloon



5.37 Number plate light bulbholder on early Fastback models

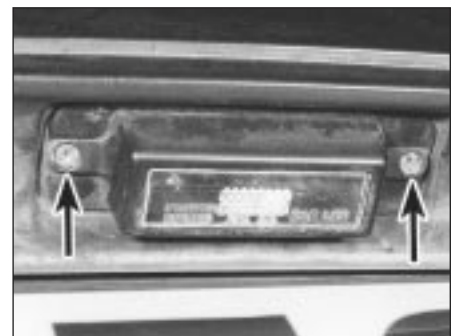

5.40 On later models, undo the number plate light unit retaining screws (arrowed) . . .



5.41 . . . squeeze the two plastic tags together and release the bulbholder from the light unit

45 Push and turn the bulb anti-clockwise to remove it from the holder.

46 Fit the new bulb, lens and retaining screws.

## 6 Bulbs (interior lights) - renewal



### Interior courtesy light

1 Carefully prise the lens from the light body using a thin blade (see illustration).

2 Remove the festoon-type bulb from the contacts.

3 Fit the new bulb and push the lens into place.

### Map reading and courtesy light

4 To renew the courtesy light bulb, carefully prise the light lens from its housing using a small screwdriver.

5 Remove the festoon-type bulb from the contacts.

6 Fit the new bulb and push the lens into place.

7 To renew the map reading light bulb, remove the courtesy light lens as just described, and undo the two light unit retaining screws.

8 Withdraw the light unit and remove the push-fit or bayonet-fit bulb.

9 Fit the new bulb and refit the light unit.

### Vanity mirror light

10 Move the light switch to the down position.

11 Carefully prise off the mirror surround from the light unit taking care that the mirror does not drop out as the surround is removed.

12 Lift the mirror out and remove the festoon bulb(s) from the holder(s).

13 Fit the new bulb(s), locate the mirror in position and refit the surround. Ensure that the switch mechanism is aligned as the surround is fitted.

### Footwell and glovebox lights

14 From within the glovebox or under the footwell as applicable, carefully prise the light from its location using a small screwdriver.

15 Release the festoon-type bulb from its contacts.

16 Fit the new bulb and push the light back into position.



6.1 Prise off the courtesy light lens

### Luggage compartment light

17 Using a small screwdriver, carefully prise the right-hand end of the light from its location under the rear parcel shelf on Saloon models, or on the rear side panels on Fastback models.

18 Withdraw the light unit, turn the bulb anti-clockwise and remove it from the light unit.

19 Fit the new bulb and push the light back into position.

### Instrument panel illumination and warning lights

20 Refer to Section 10.

### Switch illumination

#### Facia switches and heater/air conditioner control switches

21 Remove the instrument cowl as described in Section 9.

22 With the wiring multiplugs disconnected, remove the relevant bulb, which is a push-fit in the multiplug holder.

23 Fit a new bulb, then refit the instrument cowl as described in Section 9.

#### Hazard warning switch

24 Lift off the switch lens on the steering column upper shroud, and remove the push-fit bulb.

25 Fit a new bulb, and press the lens into place.

#### Steering column switches (early models)

26 Undo the three lower screws and the single upper screw, and remove the upper and lower steering column shrouds.

27 Withdraw the bulbholder from the rear of



7.3 Separate the headlight main beam wiring at the connector



6.27 Withdraw the bulbholder from the fibre optic diffuser unit

the fibre optic diffuser unit then remove the bulb from the holder (see illustration).

28 Fit a new bulb, push the bulbholder into place and refit the steering column shrouds.

## 7 Exterior light units - removal and refitting



**Note:** Ensure that all exterior lights are switched off before disconnecting the wiring connectors to any exterior light bulbs.

### Headlight lens unit

1 On pre-1992 model year vehicles, remove the radiator grille as described in Chapter 11.

2 Remove the front direction indicator light assembly as described in Section 5.

3 Disconnect the wiring multiplug at the rear of the headlight dipped beam bulb, and separate the main beam wiring at the connector (see illustration).

4 Undo the two bolts securing the headlight lens unit to the front body panel. On later models, undo the additional screw on the side of the unit accessible through the direction indicator light aperture.

5 Release the unit from the lower lugs and remove it from the car (see illustration).

6 Refitting is a reversal of removal.

### Rear light cluster assembly

#### Rear wing light cluster

7 Remove the bulb panel from the light unit as described in Section 5.



7.5 Release the lens unit from the lower lugs

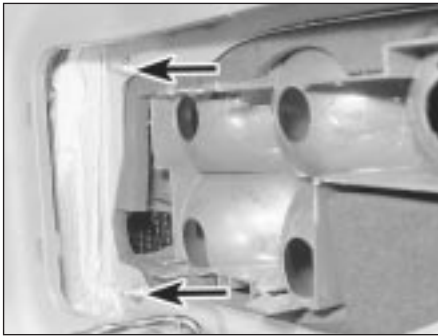

7.8a Rear light cluster side retaining nuts (arrowed)



7.8b Removing the rear light cluster assembly

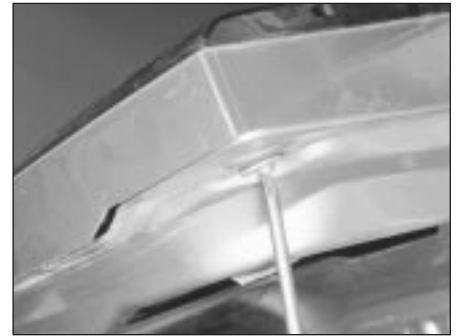

7.14 Remove the rear lens reflector and number plate assembly

8 Undo the four nuts securing the light cluster to the rear wing, and withdraw the unit from the car (see illustrations).

9 Refitting is a reversal of removal.

### Boot lid/tailgate light cluster

10 Remove the bulbholder from the light unit as described in Section 5.

11 Undo the nuts securing the light cluster to the boot lid/tailgate and withdraw the unit from the car.

12 Refitting is a reversal of removal.

### Number plate light unit

#### Pre-1992 model year

13 On Fastback models, remove the trim panel on the inside of the tailgate.

14 Undo the six retaining screws and remove the rear lens reflector and number plate assembly (see illustration).

15 Undo the two screws securing each number plate light unit and withdraw the unit(s) (see illustration).

16 Turn the bulbholder anti-clockwise to remove the bulb, then remove the light unit from the car.

17 Refitting is a reversal of removal.

#### 1992 model year onwards

18 Refer to Section 5.

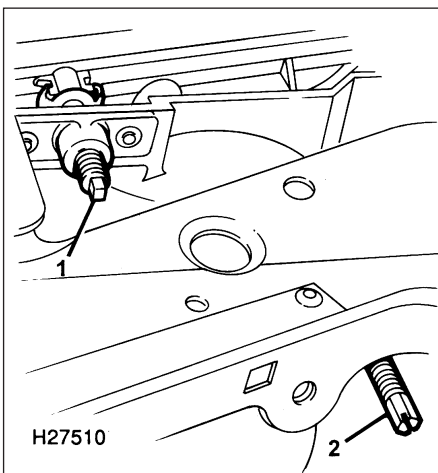

8.2 Headlight beam horizontal adjustment screw (1) and vertical adjustment screw (2)

## 8 Headlight beam alignment - checking and adjustment

1 Accurate adjustment of the headlight beam is only possible using optical beam setting equipment and this work should therefore be carried out by a Rover dealer or service station with the necessary facilities.

2 Temporary adjustment can be made when the headlight unit has been removed and refitted, or to compensate for normal adjustment whenever a heavy load is being carried. Turn the adjustment screws at the rear of the headlight unit to make the adjustment (see illustration).

3 Before making any adjustments to the headlight settings, it is important that the tyre pressures are correct and that the vehicle is standing on level ground. Bounce the front of the vehicle a few times to settle the suspension. Ideally somebody of normal size should sit in the driver's seat during the adjustment and the vehicle should have a full tank of fuel.

4 Whenever temporary adjustments are made, the settings must be reset as soon as possible once the vehicle is in normal use.

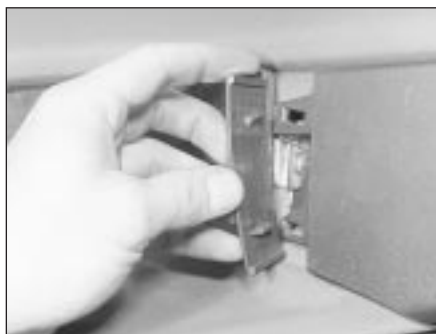

9.3a Prise out the instrument cowl cover plate . . .



7.15 Undo the two screws securing each number plate light unit

## 9 Instrument panel - removal and refitting

### Removal

1 Disconnect the battery negative (earth) lead (refer to Chapter 5, Section 1).

2 Undo the three lower screws and the single upper screw, or three lower screws only on later models, and remove the upper and lower steering column shrouds.

3 Carefully prise out the rear of the cover plate at the extreme left-hand side of the cowl and push the plate forward to release the front clips. Undo the screw behind the plate, now exposed (see illustrations).



9.3b . . . and undo the screw behind





9.5 Undo the three cowl screws (arrowed) above the instrument panel . . .



9.6 . . . and the two screws each side at the bottom

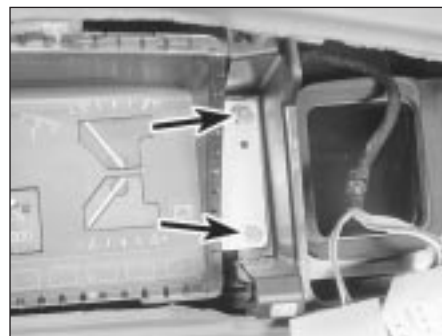

9.10 Instrument panel right-hand side retaining screws

4 Pull off the knobs on the heater controls.  
5 Undo the three screws securing the cowl to the facia above the instrument panel (see illustration).

6 Undo the two screws below the vent panel on the driver's side and the two screws below the heater/air conditioning control panel (see illustration).

7 Release the clips at the top, at each end, ease the cowl away from the facia slightly, and disconnect the switch panel and heater control/air conditioning wiring multiplugs.

8 Remove the cowl from the car.

9 Lower the steering column as far as it will go by means of the rake adjuster.

10 Undo the two screws at each end of the instrument panel (see illustration).

11 Ease the panel away from the facia, then disconnect the wiring multiplugs and the earth lead Lucar connector from the rear of the panel.

12 Remove the instrument panel from the car.

### Refitting

13 Refitting is a reversal of removal.

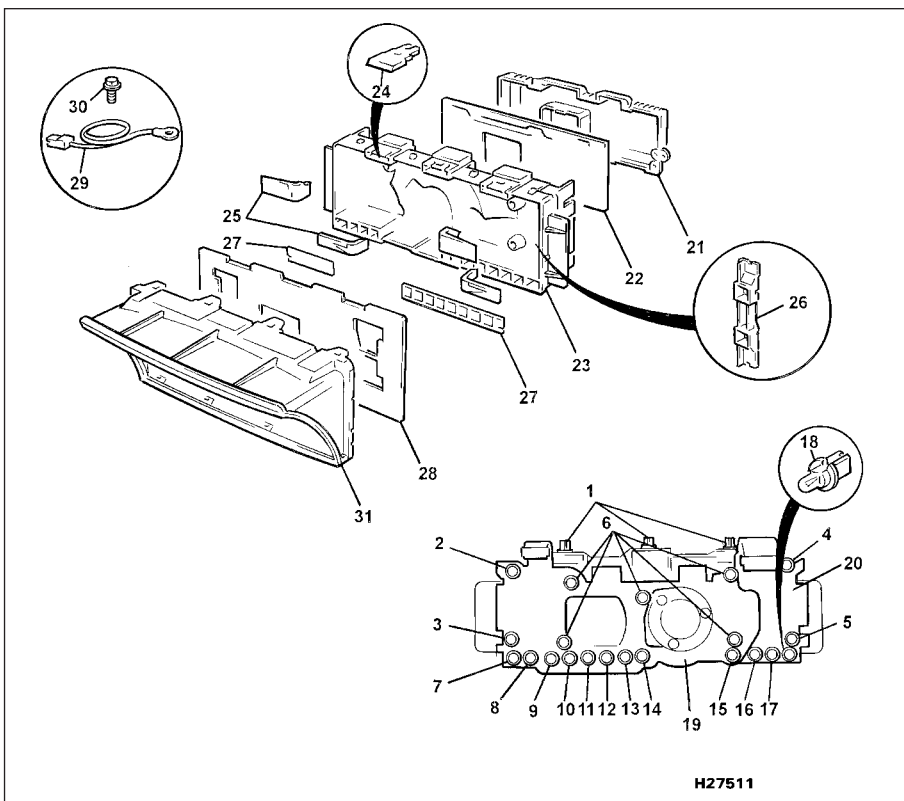

10.2a Exploded view of the instrument panel fitted to early models

- |  |   |                                |
|--|---|--------------------------------|
| 1 Panel front illumination bulbs             | 10 Spare bulb                                     | 19 Secondary printed circuit   |
| 2 Low oil pressure warning light bulb        | 11 ABS warning light bulb                         | 20 Main printed circuit        |
| 3 Ignition warning light bulb                | 12 Spare bulb                                     | 21 ECU cover                   |
| 4 High engine temperature warning light bulb | 13 Spare bulb                                     | 22 ECU                         |
| 5 Low fuel warning light bulb                | 14 Spare bulb                                     | 23 Instrument panel body       |
| 6 Panel rear illumination bulb               | 15 Sidelight warning light bulb                   | 24 Front illumination prism    |
| 7 R/H direction indicator warning light bulb | 16 Main beam warning light bulb                   | 25 Gauge illumination prism    |
| 8 Spare bulb                                 | 17 Trailer direction indicator warning light bulb | 26 Side housing                |
| 9 Brake warning light bulb                   | 18 L/H direction indicator warning light bulb     | 27 Warning light colour strips |
|  |   | 28 Faceplate                   |
|  |   | 29 Earth strap                 |
|  |   | 30 Screw                       |
|  |   | 31 Cowl and faceplate          |

### 10 Instrument panel components - removal and refitting

#### Early models

1 Remove the instrument panel from the car as described in Section 9.

#### Panel illumination and warning light bulbs

2 The bulbholders are secured to the rear of the instrument panel by a bayonet fitting, and are removed by turning the holders anti-clockwise (see illustrations). Note that the



10.2b Instrument panel warning light bulb renewal



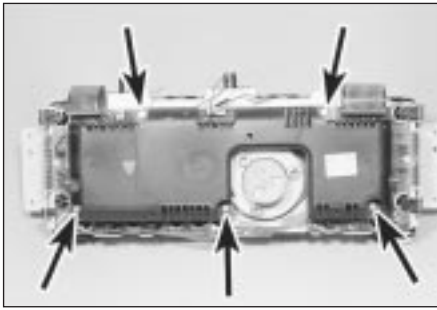

**10.3 Instrument panel ECU retaining screws (arrowed)**

illumination and warning light bulbs are renewed complete with their holders.

**3** If a faulty bulb is not accessible, undo the five screws securing the ECU to the rear of the panel, and carefully lift the ECU upwards (see illustration). Take care not to strain the ribbon connectors. The remaining bulbs are now accessible.

**4** Refit the bulbholders by turning clockwise to lock. Where applicable, lay the ECU in position and secure with the five screws.

**Instrument panel window and faceplate**

**5** Carefully release the eight clips, four at the top and four at the bottom, securing the window to the instrument panel body (see illustration).

**6** Withdraw the window and remove the faceplate.

**7** Refitting is a reversal of removal.

**Electronic control unit (ECU)**

**8** Disconnect the two ribbon connector multiplugs and the centre wiring multiplug from the top of the ECU.

**9** Undo the five screws and withdraw the ECU from the rear of the instrument panel.

**10** Refitting is a reversal of removal.

**Secondary printed circuit**

**11** Remove the ECU as described previously.

**12** Undo the two voltmeter retaining nuts.

**13** Remove the bulbholders as applicable.

**14** Undo the five printed circuit retaining screws.

**15** Release the five retaining studs.

**16** Ease the printed circuit off the two locating pins, and remove it from the rear of the panel.

**17** Refitting is a reversal of removal.

**Main printed circuit**

**18** Remove the instrument panel window and faceplate, the ECU and the secondary printed circuit as described previously

**19** Withdraw the warning light colour strips from the front of the panel.

**20** Pull off the trip reset button.

**21** Disconnect the ribbon connector from the tachometer by carefully levering off the metal retainer with a small screwdriver. Remove the metal retainer from the ribbon.

**22** Remove the bulbholders.

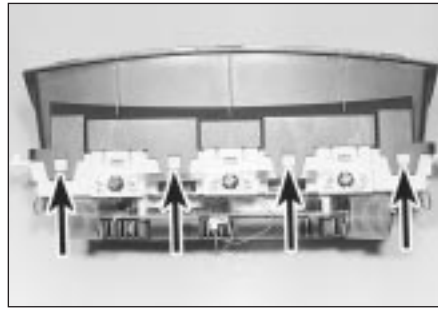

**10.5 Instrument panel window upper retaining clips (arrowed)**

**23** Undo the nuts from the gauge studs.

**24** Release the two printed circuit retaining studs.

**25** Ease the printed circuit off the locating pins, and remove it from the rear of the panel.

**26** Refitting is a reversal of removal.

**Speedometer**

**27** Remove the instrument panel window and faceplate, and the ECU as described previously.

**28** Undo the three speedometer retaining screws, release the wiring harness and remove the speedometer from the instrument panel.

**29** Refitting is a reversal of removal.

**Tachometer**

**30** Remove the instrument panel window and faceplate, and the ECU as described previously.

**31** Undo the two tachometer retaining screws.

**32** Disconnect the ribbon connector from the tachometer by carefully levering off the metal retainer with a small screwdriver. Remove the metal retainer from the ribbon.

**33** Remove the tachometer from the instrument panel.

**34** Refitting is a reversal of removal.

**Voltmeter, oil pressure, coolant temperature and fuel gauges**

**35** Remove the instrument panel window and faceplate, and the ECU as described previously.

**36** Undo the two retaining nuts and remove the relevant gauge as applicable.

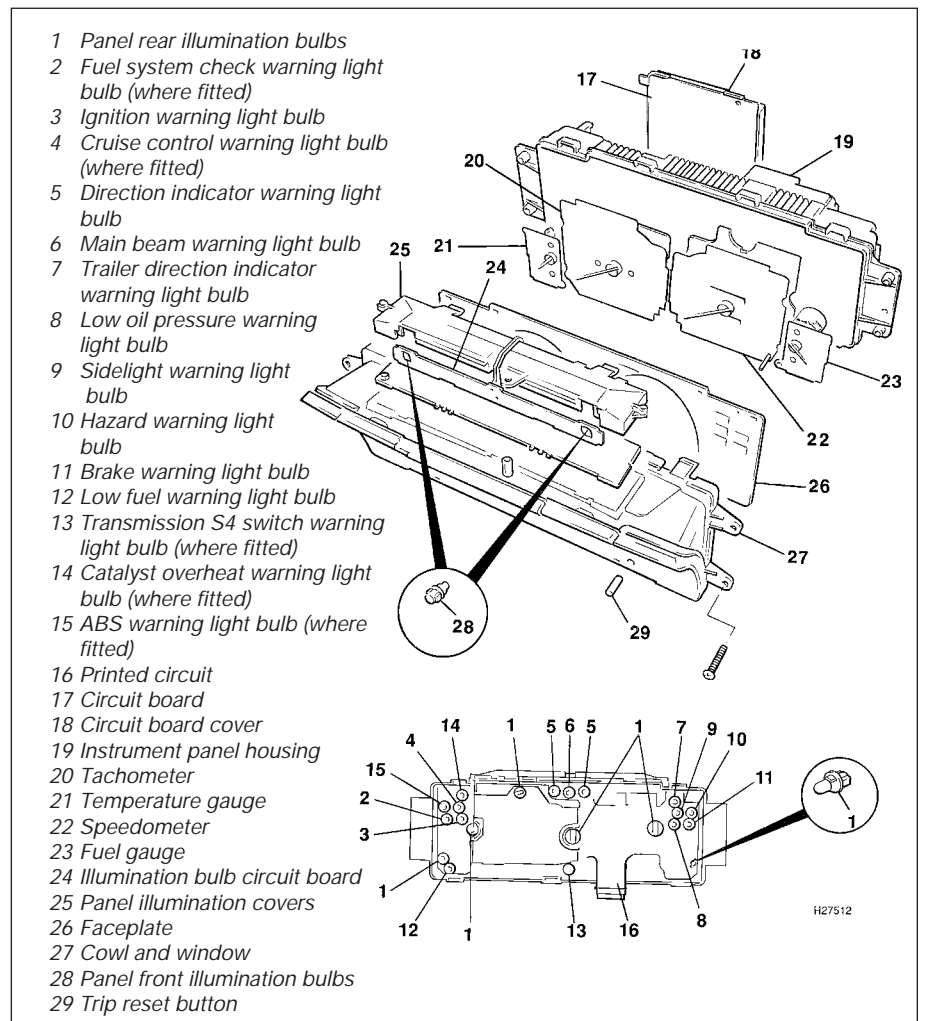

**10.39 Exploded view of the instrument panel fitted to later models**

37 Refitting is a reversal of removal.

**Later models**

38 Remove the instrument panel from the car as described in Section 9.

**Panel illumination and warning light bulbs**

39 The bulbholders are secured to the front rear of the instrument panel by a bayonet fitting, and are removed by turning the holders anti-clockwise (see illustration). Note that the illumination and warning light bulbs are renewed complete with their holders.

40 If a faulty bulb is not accessible, undo the three screws securing the circuit board and its cover to the rear of the panel. Remove the cover and carefully lift the circuit board upwards. Take care not to strain the ribbon connectors. The remaining bulbs are now accessible.

41 Refit the bulbholders by turning clockwise to lock. Where applicable, lay the circuit board in position and secure with the cover and retaining screws.

**Instrument panel window and faceplate**

42 Carefully release the eight clips, four at the top and four at the bottom, securing the window to the instrument panel body.

43 Undo the four screws, two at each end of the instrument panel.

44 Withdraw the window and release the additional bulbholder at the rear.

45 Pull off the trip reset button and remove the faceplate.

46 Refitting is a reversal of removal.

**Circuit board**

47 Disconnect the ribbon connector multiplug from the circuit board.

48 Undo the three screws and withdraw the cover and circuit board from the rear of the instrument panel.

49 Refitting is a reversal of removal.

**Tachometer**

50 Remove the instrument panel window and faceplate, and the circuit board as described previously.

51 Undo the three tachometer retaining screws and withdraw the tachometer from the instrument panel.

52 Refitting is a reversal of removal.

**Speedometer**

53 Remove the instrument panel window and faceplate, and the circuit board as described previously.

54 Undo the four small screws, and three large screws at the rear of the speedometer and withdraw it from the instrument panel.

55 Refitting is a reversal of removal.

**Coolant temperature and fuel gauges**

56 Remove the instrument panel window and faceplate and, if the temperature gauge is being removed, the circuit board, as described previously.

57 Undo the three gauge retaining screws and remove the relevant gauge from the instrument panel.

58 Refitting is a reversal of removal.

**Printed circuit**

59 Remove all the components from the instrument panel as described previously.

60 Release the printed circuit from the thirty retaining pins and remove it carefully from the instrument panel.

61 Refitting is a reversal of removal.

**11 Central control unit - description, removal and refitting**

**Description**

1 Later models are equipped with a central control unit (CCU) located under the facia behind the fusebox (see illustration). The function of the unit is to replace the various control units located behind the relay tower on earlier models, and to reduce the complexity of the wiring harness previously required.

2 The CCU incorporates a diagnostic feature for connection to a Rover dedicated test appliance.

**Removal**

3 Disconnect the battery negative (earth) lead (refer to Chapter 5, Section 1).

4 Detach the access panel or fusebox cover below the steering column.

5 Undo the retaining nut then withdraw the unit from the mounting pin.

6 Disconnect the wiring multiplugs at the rear of the unit and remove the unit from the car.

**Refitting**

7 Refitting is a reversal of removal.

**12 Clock - removal and refitting**



**Digital clock - early models**

**Removal**

1 Disconnect the battery negative (earth) lead (refer to Chapter 5, Section 1).

2 Undo the two screws at the base of the oddment tray opening.

3 Withdraw the oddment tray and disconnect the clock wiring multiplug.

4 Remove the oddment tray. Undo the two clock retaining screws and remove the clock.

**Refitting**

5 Refitting is a reversal of removal.

**Digital clock - later models**

**Removal**

6 Disconnect the battery negative (earth) lead (refer to Chapter 5, Section 1).

7 Carefully prise the clock assembly from the lower facia. The unit is retained by moulded clips which compress as the unit is withdrawn.

8 Disconnect the multiplug and remove the clock from the lower facia.

9 To renew the illumination bulb, turn the bulbholder anti-clockwise to remove.

**Refitting**

10 Refitting is a reversal of removal.

**Analogue clock**

**Removal**

11 Disconnect the battery negative (earth) lead (refer to Chapter 5, Section 1).

12 Carefully prise the clock assembly from the lower facia. The unit is retained by moulded clips on each side which compress as the unit is withdrawn.

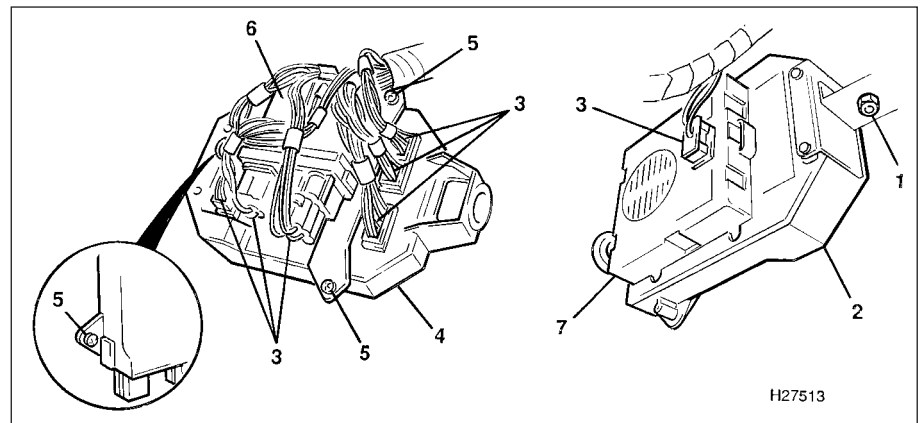

11.1 Central control unit attachments and connections

- |                                     |                                    |                                     |
|-------------------------------------|------------------------------------|-------------------------------------|
| 1 Unit retaining nut                | 3 Wiring multiplugs                | 5 Multifunction unit bracket screws |
| 2 Central control unit (front face) | 4 Central control unit (underside) | 6 Multifunction unit                |
|                                     |                                    | 7 Audible signal unit               |

**13** Disconnect the wiring connector from the rear of the illumination bulb. If the bulb is to be renewed, simply pull it from its location and fit a new bulb.

**14** Disconnect the wiring multiplugs from the clock and side switches.

**15** Undo the four nuts and remove the wood finishers from the panel. Carefully ease the finishers from the panel which are secured by double sided tape.

**16** Release the clips and withdraw the clock and switches from the panel.

#### Refitting

**17** Refitting is a reversal of removal.

### 13 Trip computer - removal and refitting



#### Trip computer and vehicle map - early models

##### Removal

**1** Disconnect the battery negative (earth) lead (refer to Chapter 5, Section 1).

**2** In order to release the trip computer retaining clips, two U-shaped rods (of the type used for radio/cassette player removal) must be inserted into the special holes on each side of the unit. If possible, it is preferable to obtain purpose made rods from an audio specialist as these have cut-outs which snap firmly into the clips so that the unit can be pulled out.

**3** Insert the special rods into the holes in the side of the unit until they engage the internal retaining clip lugs.

**4** Withdraw the unit from the lower fascia sufficiently to gain access to the wiring at the rear.

**5** Disconnect the wiring multiplugs and remove the complete assembly from the car.

**6** Release the eight retaining clips and remove the front panel.

**7** Extract the two metal clips at the top, and one at the bottom and separate the vehicle map from the trip computer.

**8** Undo the retaining screw on the side of each unit and remove the locating plates.

##### Refitting

**9** Refitting is a reversal of removal.

#### Trip computer - later models

##### Removal

**10** Disconnect the battery negative (earth) lead (refer to Chapter 5, Section 1).

**11** Carefully prise the trip computer assembly from the lower fascia. The unit is retained by moulded clips which should compress as the unit is withdrawn.

**12** Disconnect the multiplug and remove the unit from the lower fascia.

**13** To renew the illumination bulbs, turn the bulbholders anti-clockwise to remove.

##### Refitting

**14** Refitting is a reversal of removal.

### 14 Horn - removal and refitting

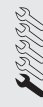

#### Removal

**1** Disconnect the battery negative (earth) lead (refer to Chapter 5, Section 1).

**2** From under the left-hand wheelarch, undo the two screws and one bolt securing the access panel and remove the panel.

**3** Disconnect the electrical leads, undo the retaining nut and remove the horn(s) from the mounting bracket.

#### Refitting

**4** Refitting is a reversal of removal.

### 15 Wiper arms - removal and refitting



#### Windscreen wiper arms

##### Removal

**1** Open the bonnet, lift the wiper arm slightly and retain it in the raised position by inserting a pop-rivet, small drill bit or similar item through the hole in the side of the arm (see illustration).

**2** Unscrew the arm-to-spindle retaining nut and withdraw the arm from the spindle.

**3** If required, remove the blade from the arm (see Chapter 1) and pull out the rivet or drill bit. Relieve the spring tension of the arm as the rivet or bit is withdrawn.

##### Refitting

**4** Refitting is a reversal of removal, but adjust the wiper arm park setting as follows during the refitting sequence.

**5** Switch on the ignition. Turn the wiper switch on and off, so that the motor operates then stops in the park position. Switch off the ignition.

**6** On early models, position the wiper arms so



**15.1** Insert a pop-rivet through the hole in the wiper arm

that they are resting on the top of the stop-pegs on the windscreen finisher.

**7** On later models position the wiper arms so that their top edge is 15 mm below the upper edge of the windscreen finisher.

**8** Engage the end of the arms with their respective spindles, and refit the retaining nut.

**9** Refit the wiper blades, remove the rivet or drill bit, and position the arms in the normal park position.

**10** Operate the washers to wet the screen, then operate the wipers.

**11** Switch the wipers off, and check that they park with the blades in the position described in paragraph 6 or 7, as applicable.

### Tailgate wiper arm (Fastback models)

#### Removal

**12** Lift off the cover over the wiper arm spindle.

**13** Unscrew the wiper arm-to-spindle retaining nut and withdraw the arm from the blade.

#### Refitting

**14** Refitting is a reversal of removal, but position the arm along the bottom of the screen with the motor in the park position.

### 16 Windscreen wiper motor and linkage - removal and refitting



#### Wiper motor

##### Removal

**1** Disconnect the battery negative (earth) lead (refer to Chapter 5, Section 1).

**2** Remove the wiper arms as described in Section 15.

**3** Carefully prise up the screw caps over the windscreen finisher retaining screws at the base of the windscreen (see illustration).

**4** Undo the screws on the finisher front face



**16.3** Prise up the windscreen finisher screw caps





16.4a Undo the screws on the finisher front face . . .



16.4b . . . and at the extreme edges



16.5a Release the rubber sealing strip retaining clips . . .

and on the extreme edges, then remove the finisher from the car (**see illustrations**).

**5** Using pointed-nose pliers, release the rubber sealing strip retaining clips (**see illustrations**). Be prepared for some of these clips to break during removal.

**6** Lift off the centre grille and the left-hand plenum moulding (**see illustrations**).

**7** Working through the left-hand plenum chamber aperture, undo the retaining nut and remove the wiper linkage rotary link from the motor spindle (**see illustration**).

**8** Disconnect the wiper motor wiring multiplug (**see illustration**).

**9** Undo the three bolts and remove the wiper motor and mounting bracket from the car (**see illustration**).

**10** Withdraw the seal from the motor spindle, then remove the seal from the mounting plate.

**11** Undo the three bolts and remove the motor from the mounting plate.

#### Refitting

**12** Refitting is a reversal of removal.

#### Wiper linkage

##### Removal

**13** Remove the wiper motor as previously described.

**14** Disconnect the primary link arm from the centre spindle assembly by pushing down to release the ball-and-socket joint. Remove the primary link.

**15** Undo the four bolts securing the centre spindle assembly, and the three bolts securing the right-hand spindle assembly, to the scuttle (**see illustrations**).

**16** Feed the right-hand spindle assembly through the scuttle aperture, and draw out the linkage from the centre spindle opening. Remove the complete linkage assembly from the car.

**17** Further dismantling is not possible, and if any of the parts are worn, a complete linkage assembly must be obtained.

##### Refitting

**18** Refitting is a reversal of removal, ensuring correct orientation of the linkage components.



16.5b . . . and withdraw the sealing strip



16.6a Lift off the centre grille . . .



16.6b . . . and the left-hand side plenum moulding



16.7 Undo the nut securing the linkage rotary link to the motor spindle



16.8 Disconnect the motor wiring multiplug

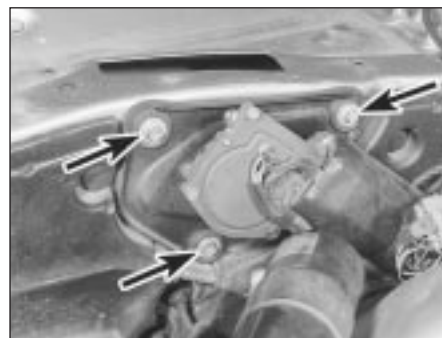

16.9 Undo the motor mounting bracket retaining nuts (arrowed)





16.15a Wiper linkage centre spindle assembly . . .



16.15b . . . and right-hand spindle assembly

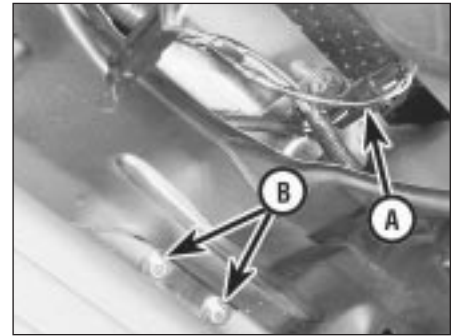

17.5 Tailgate wiper motor multiplug (A) and mounting plate retaining bolts (B)

**17 Tailgate wiper motor and linkage - removal and refitting**



**Removal**

- 1 Disconnect the battery negative (earth) lead (refer to Chapter 5, Section 1).
- 2 Remove the wiper arm as described in Section 15.
- 3 Release the plastic clip screws and remove the trim panel from inside the tailgate.
- 4 Undo the large retaining nut from the wiper motor spindle.
- 5 Disconnect the wiper motor multiplug, and release the wiring from its cable clip (see illustration).
- 6 Undo the two bolts securing the motor mounting plate to the tailgate, then withdraw the motor and mounting plate.
- 7 Undo the three bolts and remove the motor from the mounting plate.
- 8 Withdraw the seal, spacer and washer components from the motor spindle.

**Refitting**

- 9 Refitting is a reversal of removal.

**18 Windscreen/tailgate/headlight washer system components - removal and refitting**



**Washer reservoir and pumps**

**Removal**

- 1 Disconnect the battery negative (earth) lead (refer to Chapter 5, Section 1).
- 2 Undo the screw securing the washer reservoir filler neck to the inner wing valance.
- 3 Withdraw the filler neck from the reservoir, and disconnect the breather hose.
- 4 From under the wheelarch, undo the two screws and one bolt securing the access panel, and remove the panel.
- 5 Undo the three reservoir retaining bolts and lower the unit slightly.
- 6 Disconnect the fluid hoses and wiring multiplugs and remove the reservoir, complete with pumps, from under the wheelarch.

- 7 Remove the pumps as required from the reservoir by pulling them out of their locations.

**Refitting**

- 8 Refitting is a reversal of removal.

**Headlight washer jet**

**Removal**

- 9 Prise off the cover plate on the washer jet to expose the two retaining screws.
- 10 Undo the two screws and withdraw the jet from the front bumper.
- 11 Release the water hose clip, disconnect the hose and remove the jet.

**Refitting**

- 12 Refitting is a reversal of removal.

**19 Radio/cassette player - removal and refitting**



**Note:** The following procedure applies to the interior mounted radio/cassette, or radio/cassette/CD players. For procedures applicable to the luggage compartment located CD player, refer to Section 20.

**Removal**

- 1 Disconnect the battery negative (earth) lead (refer to Chapter 5, Section 1).
- 2 In order to release the radio retaining clips, two U-shaped rods must be inserted into the special holes on each side of the radio (see illustration). If possible, it is preferable to obtain purpose made rods from an audio

specialist as these have cut-outs which snap firmly into the clips so that the radio can be pulled out. Note that on later models, it will be necessary to remove the two side bezels first, to allow access to the holes for insertion of the U-shaped removal tools.

- 3 Insert the removal tools into each pair of holes at the edge of the unit, and push the tools fully home to engage the radio retaining clips.

- 4 Move the tools outward to depress the retaining clips, and withdraw the radio from the lower facia sufficiently to gain access to the wiring at the rear (see illustration).

- 5 Note the location of the speaker wiring by recording the cable colours and their positions, then disconnect the speaker leads, aerial lead and wiring multiplug(s). Remove the unit from the car.

- 6 Disengage the removal tools from the retaining clips on the side of the radio, and remove the tools.

**Refitting**

- 7 Refitting is a reversal of removal.

**20 Compact disc player - removal and refitting**



**Removal**

- 1 Disconnect the battery negative (earth) lead (refer to Chapter 5, Section 1).
- 2 From within the luggage compartment,



19.2 Insert the radio removal tools into the holes on the edges of the unit



19.4 Withdraw the radio, using the tools to release the retaining clips

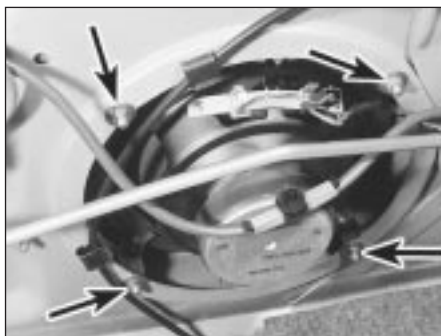

21.1 Rear speaker retaining nuts (arrowed) on Saloon and Coupe models

disconnect the wiring multiplug from the side of the unit.

3 Undo the four nuts and remove the unit from its location.

### Refitting

4 Refitting is a reversal of removal.



21.2 Removing the rear speaker from the parcel shelf

2 Withdraw the speaker upwards into the car, and remove it from the rear parcel shelf (see illustration).

### Refitting

3 Refitting is a reversal of removal.

### Rear speaker - Fastback models

#### Removal

4 Undo the three screws securing the trim panel to the parcel tray support and remove the trim panel (see illustration).

5 Remove the speaker grille.

6 Undo the six speaker retaining screws, lift the speaker from its location and disconnect the wiring connectors (see illustration).

7 Remove the speaker from the car.

#### Refitting

8 Refitting is a reversal of removal.

### Front main speaker and filter

#### Removal

9 Remove the front door inner trim panel as described in Chapter 11.

10 Undo the four screws securing the speaker to the door (see illustration).

11 Withdraw the speaker, disconnect the leads and remove the speaker from the door (see illustration).

12 To remove the filter, cut off the tape securing it to the wiring harness adjacent to the main speaker location.

13 Disconnect the leads at each end and remove the filter.



21.4 Remove the trim panel over the rear speaker on Fastback models

### Refitting

14 Refitting is a reversal of removal.

### Tweeter

#### Removal

15 Refer to Chapter 11, Section 21 and remove the escutcheon around the door inner release handle.

16 Rotate the tweeter clockwise to release it from the escutcheon, then disconnect the leads and remove the tweeter (see illustration).

#### Refitting

17 Refitting is a reversal of removal.

## 21 Speakers - removal and refitting



### Rear speaker - Saloon and Coupe models

#### Removal

1 From inside the luggage compartment, disconnect the two leads and undo the four retaining nuts (see illustration).

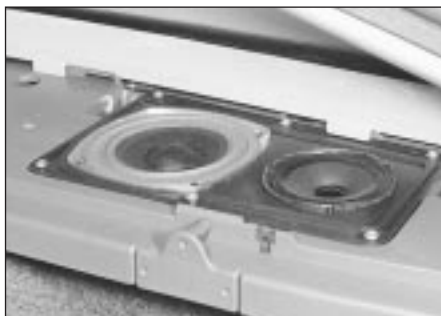

21.6 Undo the six screws and remove the speaker assembly



21.10 Undo the main door speaker retaining screws



21.11 Withdraw the speaker and disconnect the wiring

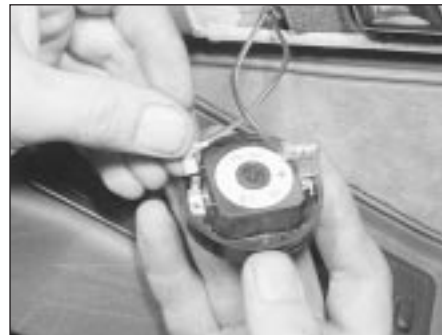

21.16 Disconnect the wiring and remove the tweeter

## 22 Aerial amplifier - removal and refitting



### Saloon and Coupe models

#### Removal

**Note:** The aerial amplifier is located below the rear parcel shelf on pre-1992 models, and above it on later models.

1 Disconnect the battery negative (earth) lead (refer to Chapter 5, Section 1).

2 On later models, remove the rear speakers (Section 21), fold the seat squabs forward and remove the parcel tray and insulation pad.

3 From inside the luggage or passenger compartment, as applicable, disconnect the



**22.3** Aerial amplifier unit located under the rear parcel shelf on early Saloon models

two leads at the amplifier unit (see illustration).

**4** Disconnect the two amplifier leads at the connections to the rear screen demisting element.

**5** Disconnect the aerial co-axial lead at the amplifier.

**6** Undo the two screws and remove the amplifier from under the parcel shelf.

#### Refitting

**7** Refitting is a reversal of removal.

#### Fastback models

#### Removal

**8** Disconnect the battery negative (earth) lead (refer to Chapter 5, Section 1).

**9** Remove the trim panel from inside the tailgate.

**10** Disconnect the leads at the amplifier unit located behind the stiffener panel in the tailgate.

**11** Disconnect the leads at the connector to the rear screen demisting element.

**12** Disconnect the aerial co-axial lead at the amplifier.

**13** Undo the two bolts and remove the amplifier from the tailgate (see illustration). Note that one bolt also secures the wiring earth cable.

#### Refitting

**14** Refitting is a reversal of removal.

### 23 Power amplifier - removal and refitting



#### Facia-mounted amplifier - early models

#### Removal

**1** Disconnect the battery negative (earth) lead (refer to Chapter 5, Section 1).

**2** Release the turnbuckles and remove the trim panel over the fusebox, beneath the steering column.

**3** Remove the radio cassette player as described in Section 19.

**4** Disconnect the four multiplugs connecting

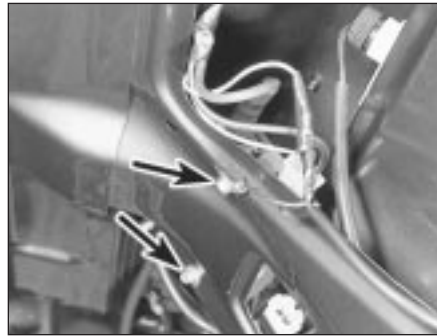

**22.13** Aerial amplifier unit retaining bolts (arrowed) on Fastback models

the speaker leads from the power amplifier to the wiring harness. Record the colour codes of each lead to ensure correct connection on reassembly.

**5** Release the retaining stud and remove the small centre console trim panel from the footwell on the driver's side.

**6** Working through the trim panel aperture, disconnect the power amplifier wiring multiplug.

**7** Undo the nut and two screws securing the power amplifier mounting bracket under the facia.

**8** Withdraw the amplifier, release the wiring harness, and remove the unit from under the facia.

#### Refitting

**9** Refitting is a reversal of removal.

#### Luggage compartment-mounted amplifier - later models

#### Removal

**10** Disconnect the battery negative (earth) lead (refer to Chapter 5, Section 1).

**11** Remove the trim panel from the right-hand side of the luggage compartment.

**12** Disconnect the rear speaker leads at the speakers or at the wiring connectors, and pass the disconnected leads through to the amplifier.

**13** Disconnect the two multiplugs and the DIN socket connector at the amplifier.

**14** Undo the two amplifier mounting bracket screws, and remove the unit from the luggage compartment.

#### Refitting

**15** Refitting is a reversal of removal.

### 24 Anti-theft system - general information

Later models are fitted with an anti-theft system as an additional security measure. The system is armed automatically whenever the vehicle is locked (by key or infra-red handset); the system cannot be armed by pressing the internal door lock buttons.

In the event of the vehicle being broken into, the alarm will be activated. It will also sound if the ignition key is inserted into the ignition switch whilst the alarm is armed, and additionally, when the system is being armed and a door is not fully closed. Note that the bonnet must also be fully closed to enable the system to be armed.

On later models, an additional ultrasonic space protection feature is incorporated into the system. This uses two sensors mounted at the top of the left-hand door pillars to detect movement inside the vehicle (such as entry being gained through a broken window). In the event of such movement being detected, the alarm will be activated. This feature can be disabled if required (for example, if the car is to be briefly locked with animals inside).

The anti-theft alarm system is controlled by the ignition/starter circuit, the door courtesy light switches, the boot/tailgate light switches and the central control unit (CCU).

### 25 Anti-theft system components - removal and refitting



**Note:** The following procedures apply to those components dedicated to the anti-theft alarm system. Removal and refitting procedures for the central control unit (CCU) and the door/boot/tailgate light switches will be found in Sections 11 and 4 respectively. At the time of writing no information was available relating to the ultrasonic space detection sensor.

#### Alarm siren

#### Removal

**1** Remove the wiper arms as described in Section 15.

**3** Carefully prise up the screw caps over the windscreen finisher retaining screws at the base of the windscreen (see illustration overleaf).

**4** Undo the screws on the finisher front face and on the extreme edges, then remove the finisher from the car.

**5** Using pointed-nose pliers, release the rubber sealing-strip retaining clips. Be prepared for some of these clips to break during removal.

**6** Lift off the centre grille and the right-hand plenum moulding.

**7** Release the wiring harness from the support bracket and disconnect the wiring multiplug.

**8** Undo the two retaining screws and remove the siren from the plenum chamber.

#### Refitting

**9** Refitting is a reversal of removal. Adjust the wiper arm park position as described in Section 15, when refitting the arms.

### Bonnet switch

#### Removal

10 Open the bonnet and disconnect the in-line wiring connector to the switch.

11 Compress the retaining clips and withdraw the bonnet switch from the mounting panel.

#### Refitting

12 Refitting is a reversal of removal.

### 26 Airbag supplementary restraint system - general information

Later models are fitted with a driver's airbag, which is designed to prevent serious chest and head injuries to the driver during an accident. A similar bag for the front seat passenger is also available. The two crash sensors which detect frontal impact are located on either side of the engine compartment while the electronic control unit for the airbag is located in the passenger compartment in front of the centre console. The airbag is inflated by an igniter, which forces the bag out of the module cover in the centre of the steering wheel, or out of a cover on the passenger's side of the facia. A rotary coupler behind the steering wheel at the top of the steering column, ensures that a good electrical connection is maintained with the airbag at all times as the steering wheel is turned in each direction.

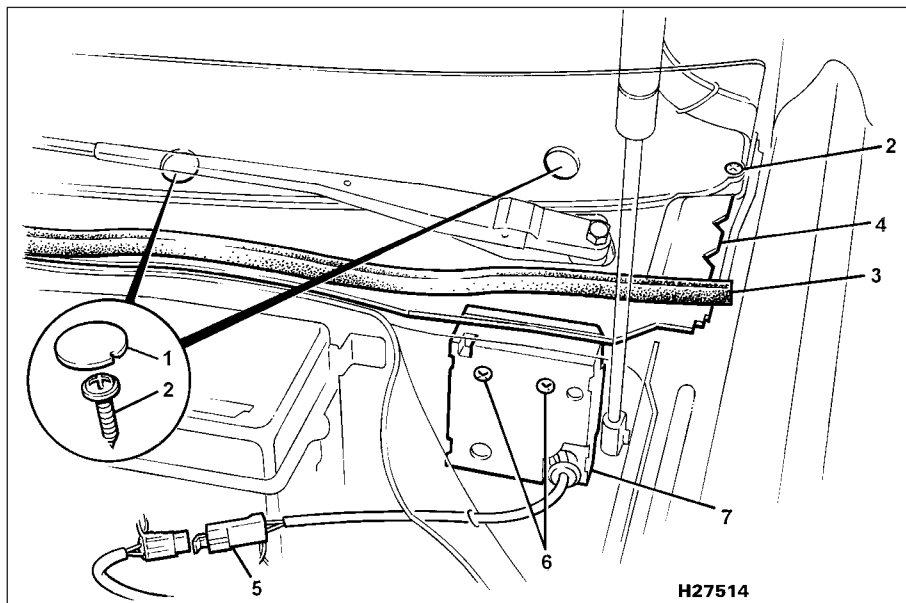

25.3 Anti-theft alarm siren unit location

- |  |                        |                               |
|--|------------------------|-------------------------------|
| 1 Screw caps                           | 3 Rubber sealing strip | 6 Siren unit retaining screws |
| 2 Windscreen finisher retaining screws | 4 Plenum moulding      | 7 Siren unit                  |
|  | 5 Wiring multiplug     |                               |



**Warning:** Procedures for removal and refitting of the driver's side airbag module and rotary coupler are given in Chapter 10, Sections 18 and 19 respectively. Those procedures are provided solely to allow removal and refitting of the steering wheel and associated components as part of a normal repair operation. Do not attempt to carry out any other work whatsoever on the airbag supplementary restraint system components. Any diagnosis or repair necessary, must be carried out by a Rover dealer.



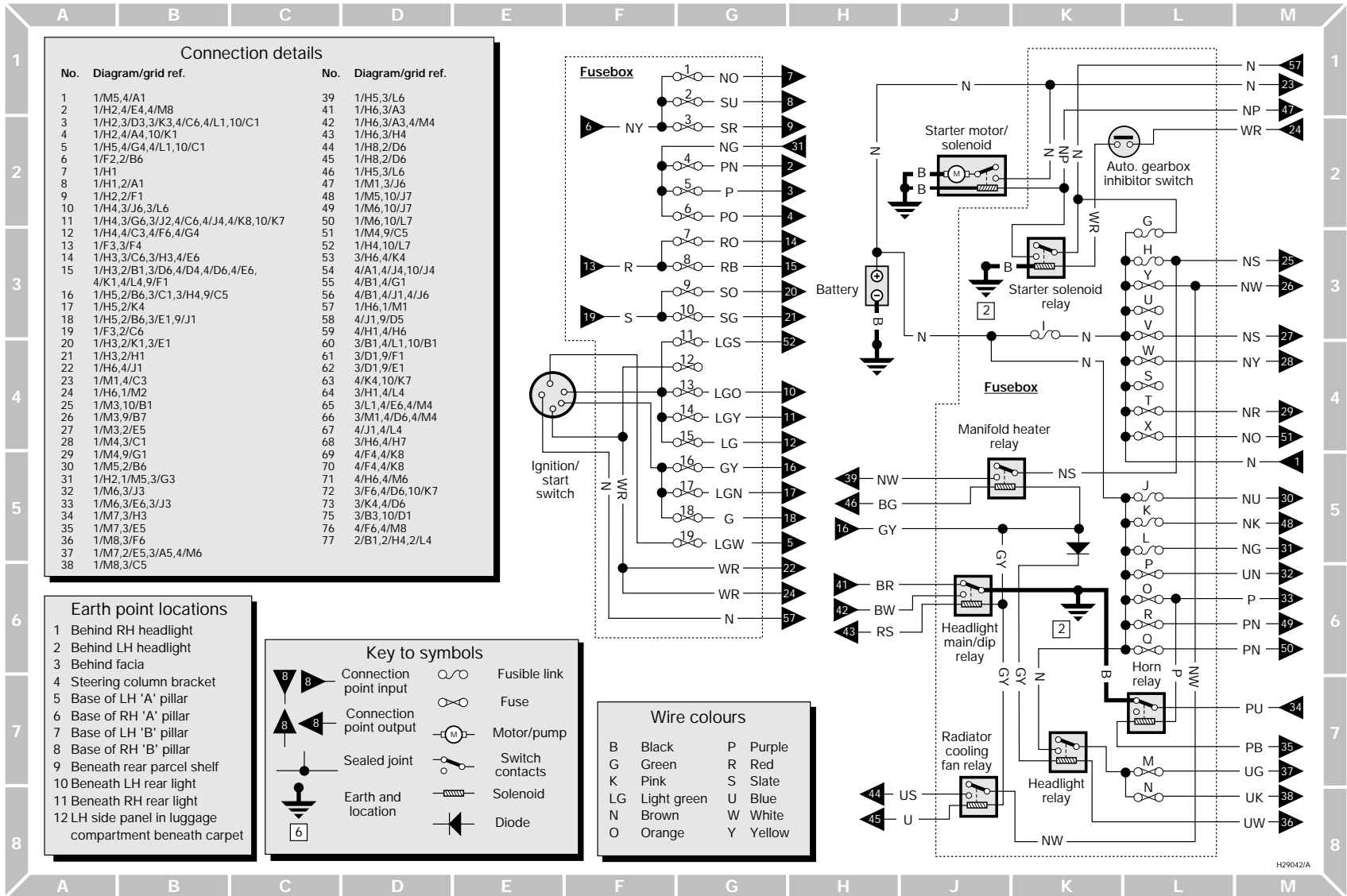

Diagram 1: Main wiring diagram (typical) - single-point fuel injection models



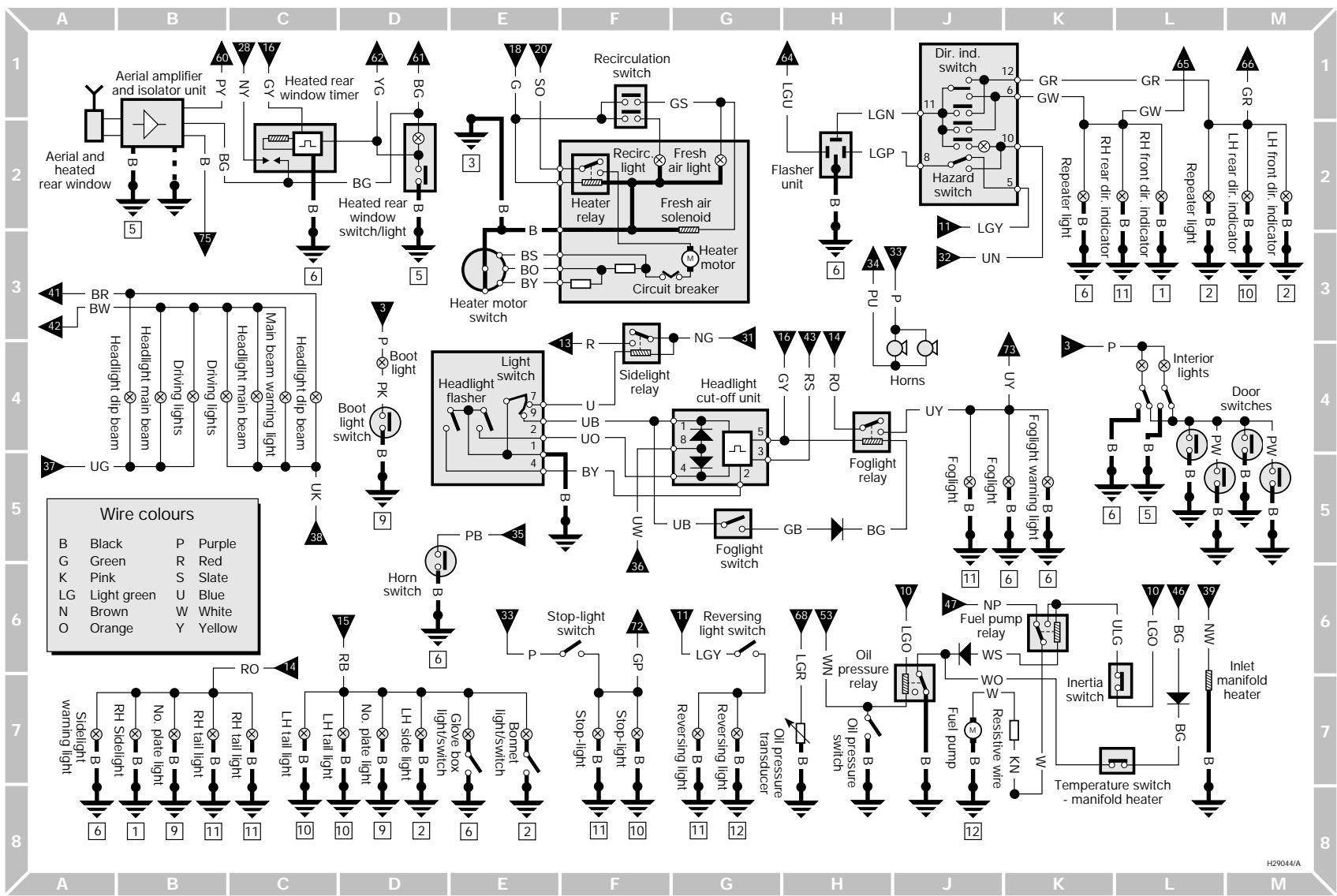

Diagram 3: Main wiring diagram (typical) - single-point fuel injection models (continued)

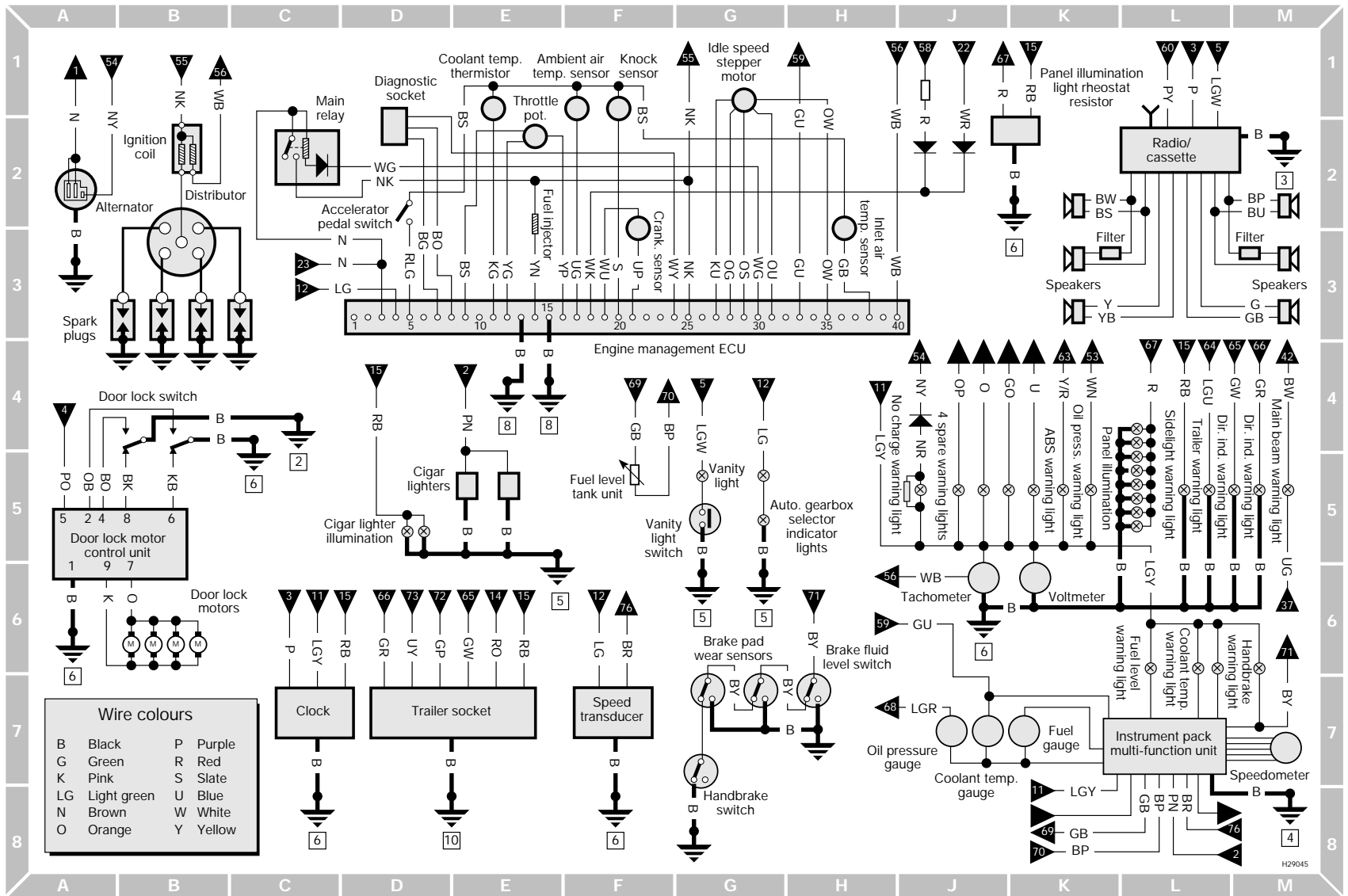

Diagram 4: Main wiring diagram (typical) - single-point fuel injection models (continued)

1380 Rover 800 Series Remake

H29045



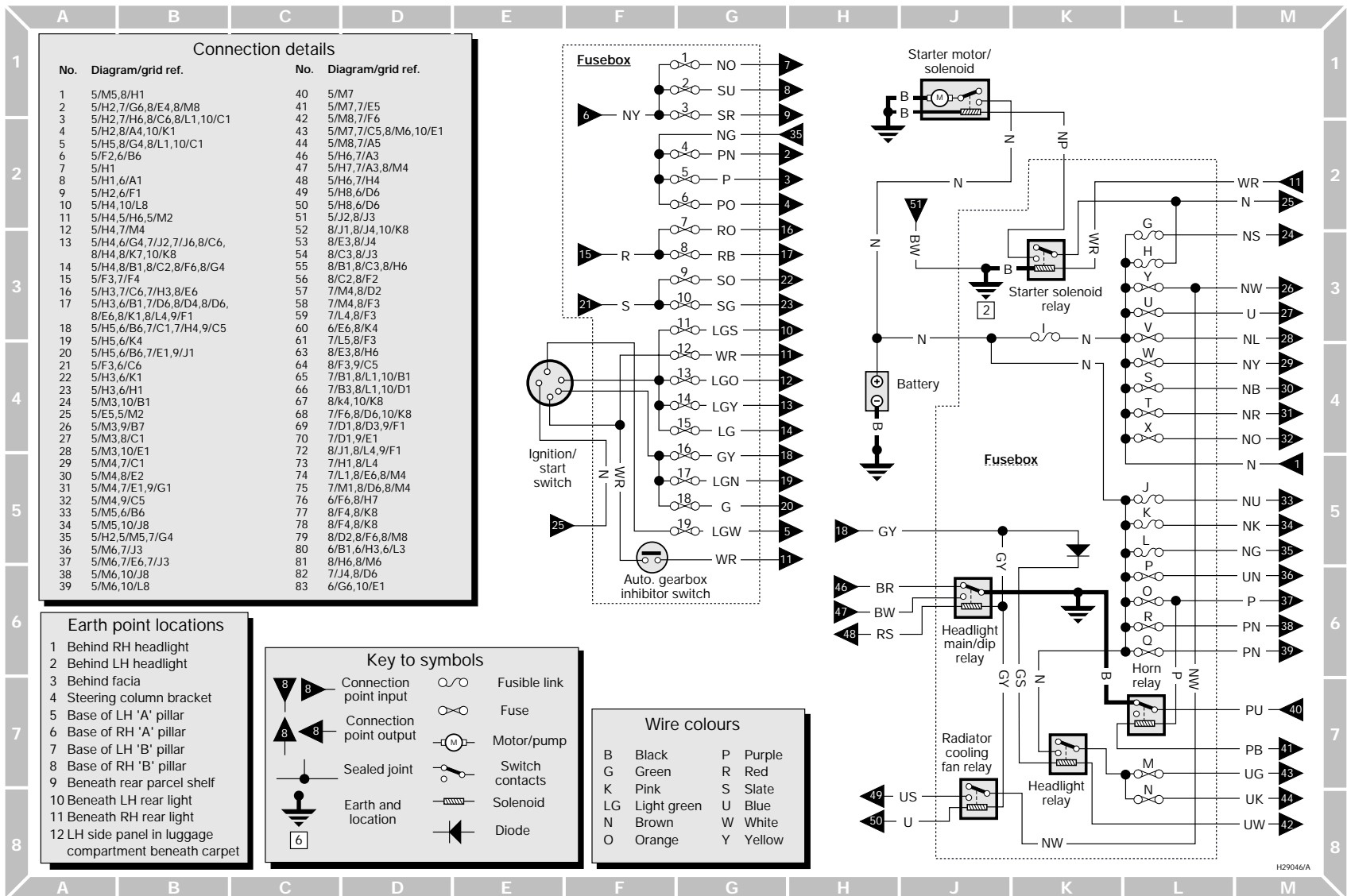

Diagram 5: Main wiring diagram (typical) - multi-point fuel injection models

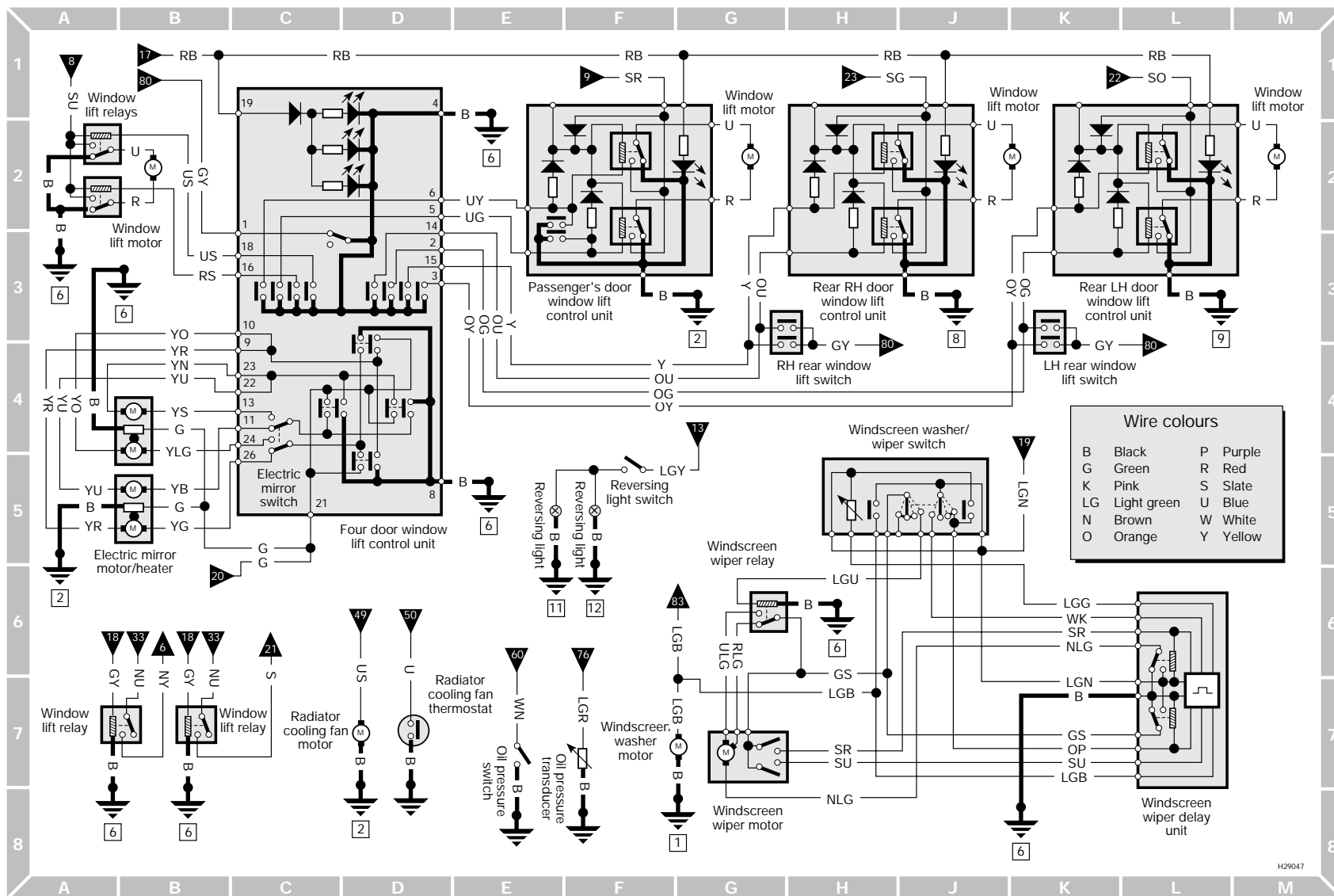

Diagram 6: Main wiring diagram (typical) - multi-point fuel injection models (continued)

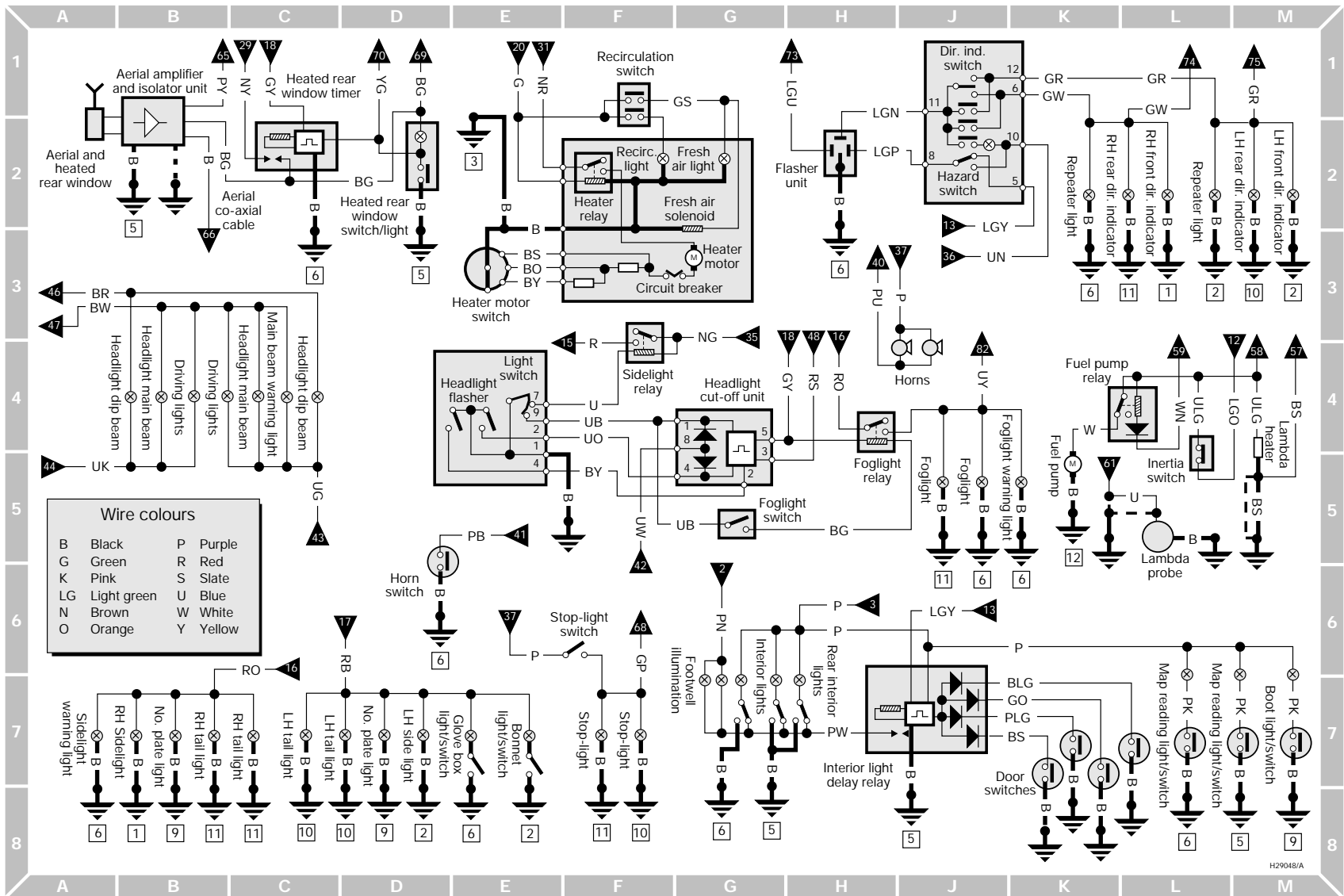

Diagram 7: Main wiring diagram (typical) - multi-point fuel injection models (continued)

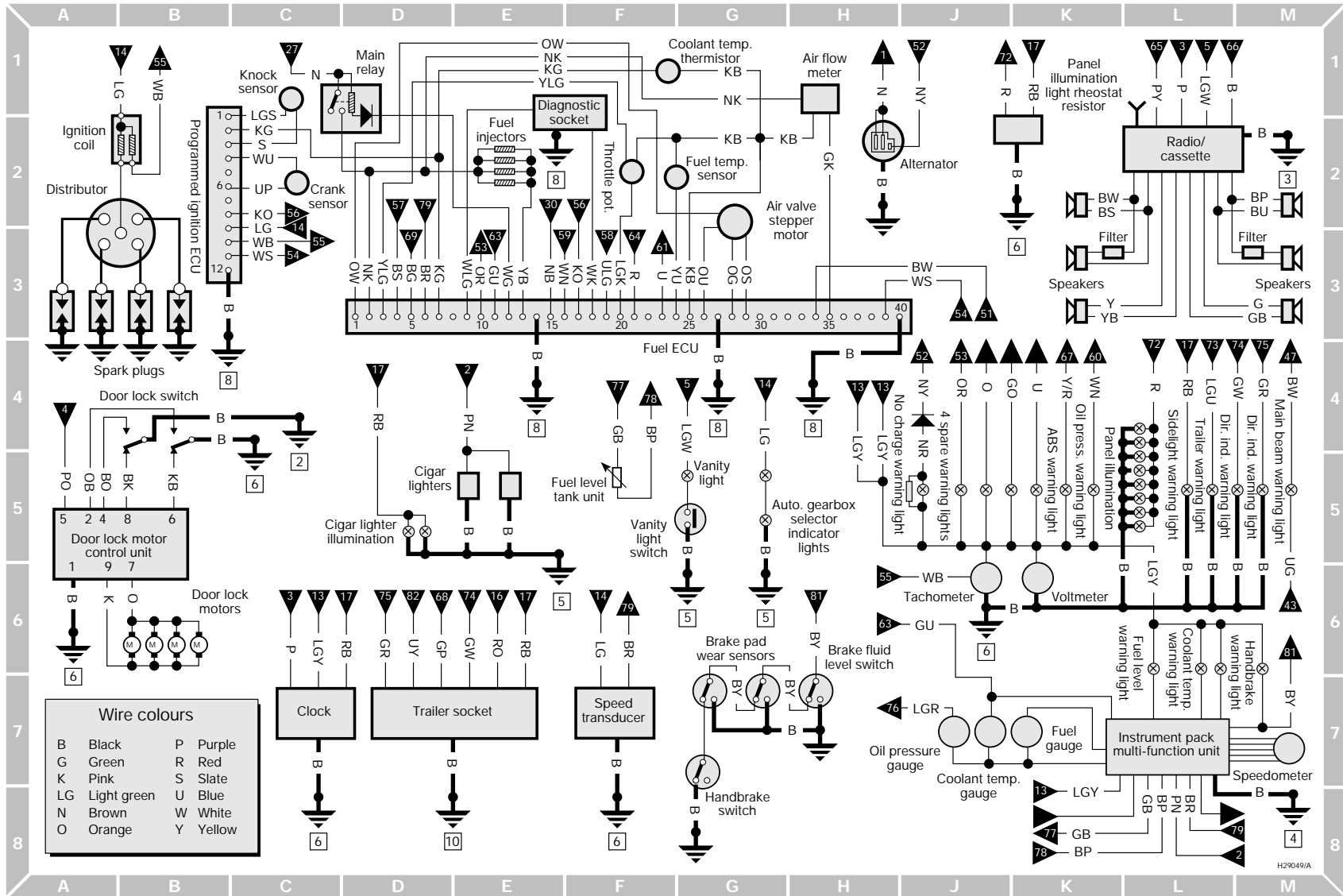

Diagram 8: Main wiring diagram (typical) - multi-point fuel injection models (continued)

1380 Rover 800 Series Remake

H29049/A



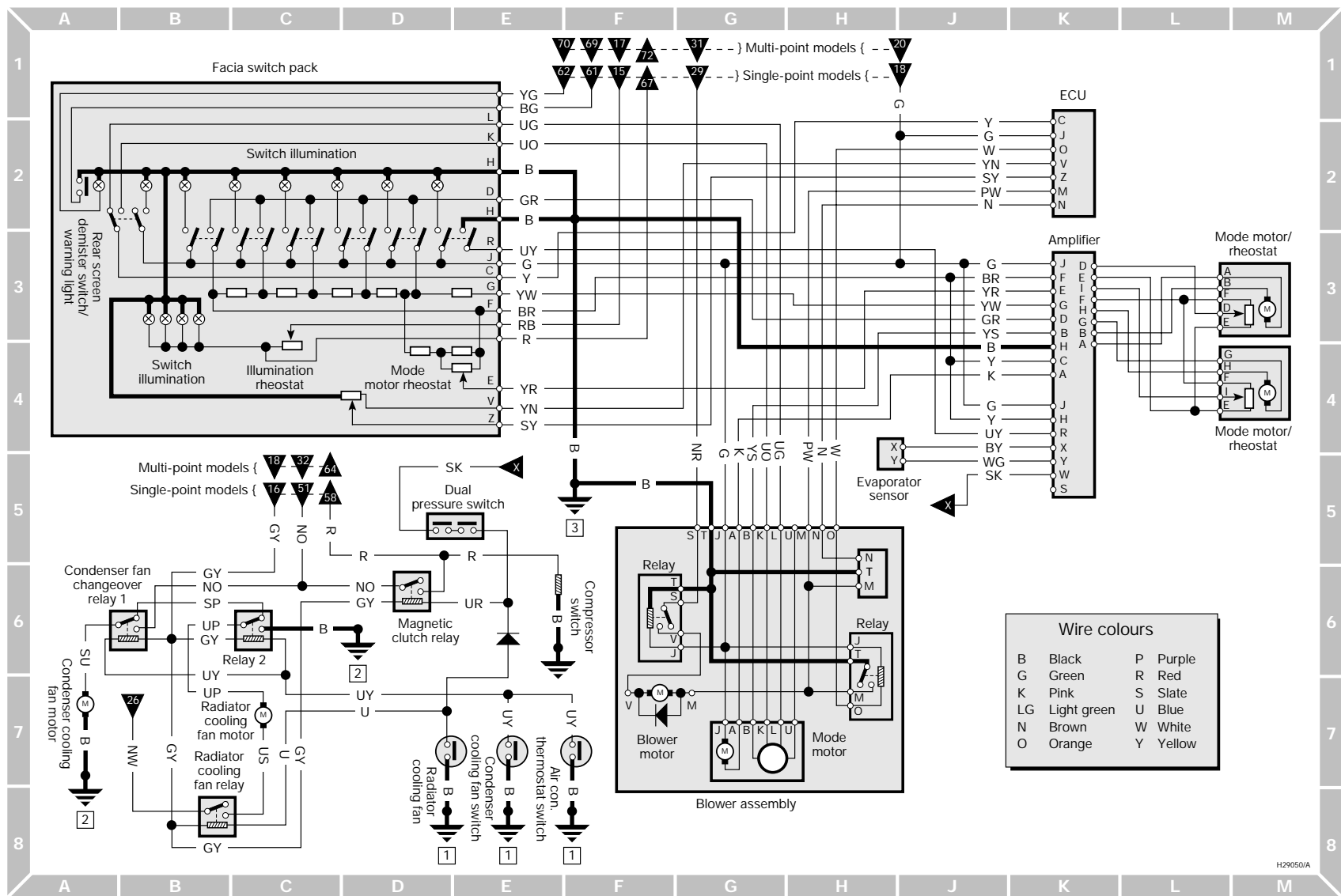

Diagram 9: Typical air conditioning system (including engine cooling fan)

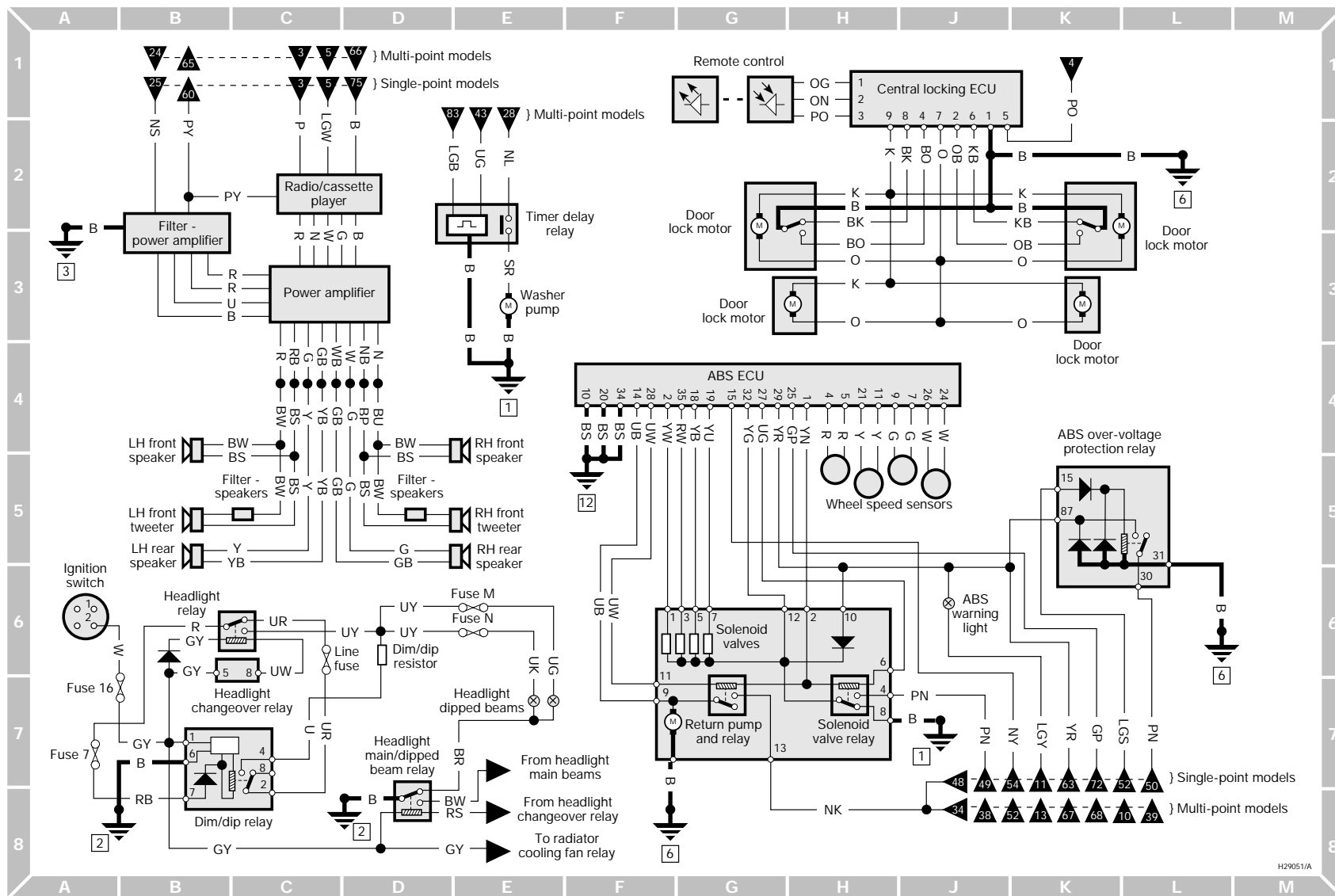

Diagram 10: Supplementary circuits

Diagram 10: Supplementary circuits

This is a guide to getting your vehicle through the MOT test. Obviously it will not be possible to examine the vehicle to the same standard as the professional MOT tester. However, working through the following checks will enable you to identify any problem areas before submitting the vehicle for the test.

Where a testable component is in borderline condition, the tester has discretion in deciding whether to pass or fail it. The basis of such discretion is whether the tester would be happy for a close relative or friend to use the vehicle with the component in that condition. If the vehicle presented is clean and evidently well cared for, the tester may be more inclined to pass a borderline component than if the vehicle is scruffy and apparently neglected.

It has only been possible to summarise the test requirements here, based on the regulations in force at the time of printing. Test standards are becoming increasingly stringent, although there are some exemptions for older vehicles. For full details obtain a copy of the Haynes publication *Pass the MOT!* (available from stockists of Haynes manuals).

An assistant will be needed to help carry out some of these checks.



The checks have been sub-divided into four categories, as follows:

**1** Checks carried out **FROM THE DRIVER'S SEAT**

**2** Checks carried out **WITH THE VEHICLE ON THE GROUND**

**3** Checks carried out **WITH THE VEHICLE RAISED AND THE WHEELS FREE TO TURN**

**4** Checks carried out on **YOUR VEHICLE'S EXHAUST EMISSION SYSTEM**

**1** Checks carried out **FROM THE DRIVER'S SEAT**

## Handbrake

- Test the operation of the handbrake. Excessive travel (too many clicks) indicates incorrect brake or cable adjustment.
- Check that the handbrake cannot be released by tapping the lever sideways. Check the security of the lever mountings.



## Footbrake

- Depress the brake pedal and check that it does not creep down to the floor, indicating a master cylinder fault. Release the pedal, wait a few seconds, then depress it again. If the pedal travels nearly to the floor before firm resistance is felt, brake adjustment or repair is necessary. If the pedal feels spongy, there is air in the hydraulic system which must be removed by bleeding.



- Check that the brake pedal is secure and in good condition. Check also for signs of fluid leaks on the pedal, floor or carpets, which would indicate failed seals in the brake master cylinder.
- Check the servo unit (when applicable) by operating the brake pedal several times, then keeping the pedal depressed and starting the engine. As the engine starts, the pedal will move down slightly. If not, the vacuum hose or the servo itself may be faulty.

## Steering wheel and column

- Examine the steering wheel for fractures or looseness of the hub, spokes or rim.
- Move the steering wheel from side to side and then up and down. Check that the steering wheel is not loose on the column, indicating wear or a loose retaining nut. Continue moving the steering wheel as before, but also turn it slightly from left to right.
- Check that the steering wheel is not loose on the column, and that there is no abnormal



movement of the steering wheel, indicating wear in the column support bearings or couplings.

## Windscreen and mirrors

- The windscreen must be free of cracks or other significant damage within the driver's field of view. (Small stone chips are acceptable.) Rear view mirrors must be secure, intact, and capable of being adjusted.

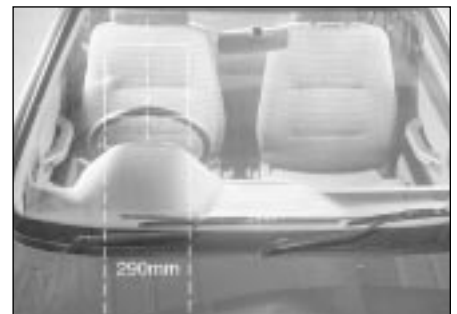



## Seat belts and seats

**Note:** The following checks are applicable to all seat belts, front and rear.

- Examine the webbing of all the belts (including rear belts if fitted) for cuts, serious fraying or deterioration. Fasten and unfasten each belt to check the buckles. If applicable, check the retracting mechanism. Check the security of all seat belt mountings accessible from inside the vehicle.
- The front seats themselves must be securely attached and the backrests must lock in the upright position.

## Doors

- Both front doors must be able to be opened and closed from outside and inside, and must latch securely when closed.

**2** Checks carried out  
**WITH THE VEHICLE ON THE  
GROUND**

## Vehicle identification

- Number plates must be in good condition, secure and legible, with letters and numbers correctly spaced – spacing at (A) should be twice that at (B).



- The VIN plate and/or homologation plate must be legible.



## Electrical equipment

- Switch on the ignition and check the operation of the horn.
- Check the windscreen washers and wipers, examining the wiper blades; renew damaged or perished blades. Also check the operation of the stop-lights.



- Check the operation of the sidelights and number plate lights. The lenses and reflectors must be secure, clean and undamaged.
- Check the operation and alignment of the headlights. The headlight reflectors must not be tarnished and the lenses must be undamaged.
- Switch on the ignition and check the operation of the direction indicators (including the instrument panel tell-tale) and the hazard warning lights. Operation of the sidelights and stop-lights must not affect the indicators - if it does, the cause is usually a bad earth at the rear light cluster.
- Check the operation of the rear foglight(s), including the warning light on the instrument panel or in the switch.

## Footbrake

- Examine the master cylinder, brake pipes and servo unit for leaks, loose mountings, corrosion or other damage.



- The fluid reservoir must be secure and the fluid level must be between the upper (A) and lower (B) markings.

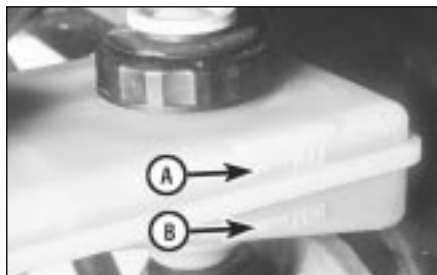

- Inspect both front brake flexible hoses for cracks or deterioration of the rubber. Turn the steering from lock to lock, and ensure that the hoses do not contact the wheel, tyre, or any part of the steering or suspension mechanism. With the brake pedal firmly depressed, check the hoses for bulges or leaks under pressure.



## Steering and suspension

- Have your assistant turn the steering wheel from side to side slightly, up to the point where the steering gear just begins to transmit this movement to the roadwheels. Check for excessive free play between the steering wheel and the steering gear, indicating wear or insecurity of the steering column joints, the column-to-steering gear coupling, or the steering gear itself.
- Have your assistant turn the steering wheel more vigorously in each direction, so that the roadwheels just begin to turn. As this is done, examine all the steering joints, linkages, fittings and attachments. Renew any component that shows signs of wear or damage. On vehicles with power steering, check the security and condition of the steering pump, drivebelt and hoses.
- Check that the vehicle is standing level, and at approximately the correct ride height.

## Shock absorbers

- Depress each corner of the vehicle in turn, then release it. The vehicle should rise and then settle in its normal position. If the vehicle continues to rise and fall, the shock absorber is defective. A shock absorber which has seized will also cause the vehicle to fail.





## Exhaust system

□ Start the engine. With your assistant holding a rag over the tailpipe, check the entire system for leaks. Repair or renew leaking sections.

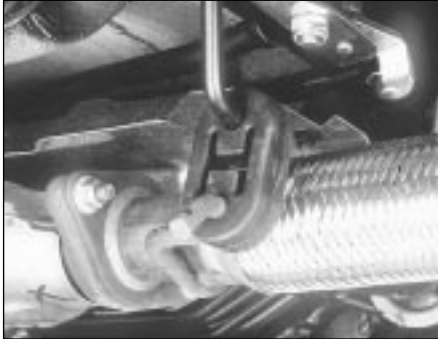

**3** Checks carried out  
**WITH THE VEHICLE RAISED  
AND THE WHEELS FREE TO  
TURN**

*Jack up the front and rear of the vehicle, and securely support it on axle stands. Position the stands clear of the suspension assemblies. Ensure that the wheels are clear of the ground and that the steering can be turned from lock to lock.*

## Steering mechanism

□ Have your assistant turn the steering from lock to lock. Check that the steering turns smoothly, and that no part of the steering mechanism, including a wheel or tyre, fouls any brake hose or pipe or any part of the body structure.

□ Examine the steering rack rubber gaiters for damage or insecurity of the retaining clips. If power steering is fitted, check for signs of damage or leakage of the fluid hoses, pipes or connections. Also check for excessive stiffness or binding of the steering, a missing split pin or locking device, or severe corrosion of the body structure within 30 cm of any steering component attachment point.



## Front and rear suspension and wheel bearings

□ Starting at the front right-hand side, grasp the roadwheel at the 3 o'clock and 9 o'clock positions and shake it vigorously. Check for free play or insecurity at the wheel bearings, suspension balljoints, or suspension mountings, pivots and attachments.

□ Now grasp the wheel at the 12 o'clock and 6 o'clock positions and repeat the previous inspection. Spin the wheel, and check for roughness or tightness of the front wheel bearing.



□ If excess free play is suspected at a component pivot point, this can be confirmed by using a large screwdriver or similar tool and levering between the mounting and the component attachment. This will confirm whether the wear is in the pivot bush, its retaining bolt, or in the mounting itself (the bolt holes can often become elongated).



□ Carry out all the above checks at the other front wheel, and then at both rear wheels.

## Springs and shock absorbers

□ Examine the suspension struts (when applicable) for serious fluid leakage, corrosion, or damage to the casing. Also check the security of the mounting points.

□ If coil springs are fitted, check that the spring ends locate in their seats, and that the spring is not corroded, cracked or broken.

□ If leaf springs are fitted, check that all leaves are intact, that the axle is securely attached to each spring, and that there is no deterioration of the spring eye mountings, bushes, and shackles.

□ The same general checks apply to vehicles fitted with other suspension types, such as torsion bars, hydraulic displacer units, etc. Ensure that all mountings and attachments are secure, that there are no signs of excessive wear, corrosion or damage, and (on hydraulic types) that there are no fluid leaks or damaged pipes.

□ Inspect the shock absorbers for signs of serious fluid leakage. Check for wear of the mounting bushes or attachments, or damage to the body of the unit.

## Driveshafts (fwd vehicles only)

□ Rotate each front wheel in turn and inspect the constant velocity joint gaiters for splits or damage. Also check that each driveshaft is straight and undamaged.



## Braking system

□ If possible without dismantling, check brake pad wear and disc condition. Ensure that the friction lining material has not worn excessively, (A) and that the discs are not fractured, pitted, scored or badly worn (B).

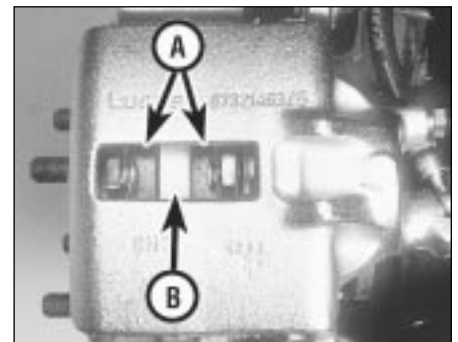

□ Examine all the rigid brake pipes underneath the vehicle, and the flexible hose(s) at the rear. Look for corrosion, chafing or insecurity of the pipes, and for signs of bulging under pressure, chafing, splits or deterioration of the flexible hoses.

□ Look for signs of fluid leaks at the brake calipers or on the brake backplates. Repair or renew leaking components.

□ Slowly spin each wheel, while your assistant depresses and releases the footbrake. Ensure that each brake is operating and does not bind when the pedal is released.

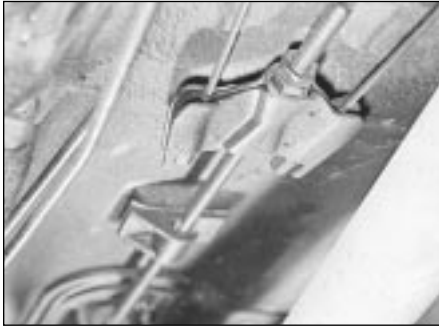

- Examine the handbrake mechanism, checking for frayed or broken cables, excessive corrosion, or wear or insecurity of the linkage. Check that the mechanism works on each relevant wheel, and releases fully, without binding.
- It is not possible to test brake efficiency without special equipment, but a road test can be carried out later to check that the vehicle pulls up in a straight line.

### Fuel and exhaust systems

- Inspect the fuel tank (including the filler cap), fuel pipes, hoses and unions. All components must be secure and free from leaks.
- Examine the exhaust system over its entire length, checking for any damaged, broken or missing mountings, security of the retaining clamps and rust or corrosion.



### Wheels and tyres

- Examine the sidewalls and tread area of each tyre in turn. Check for cuts, tears, lumps, bulges, separation of the tread, and exposure of the ply or cord due to wear or damage. Check that the tyre bead is correctly seated on the wheel rim, that the valve is sound and



- properly seated, and that the wheel is not distorted or damaged.
- Check that the tyres are of the correct size for the vehicle, that they are of the same size and type on each axle, and that the pressures are correct.
- Check the tyre tread depth. The legal minimum at the time of writing is 1.6 mm over at least three-quarters of the tread width. Abnormal tread wear may indicate incorrect front wheel alignment.

### Body corrosion

- Check the condition of the entire vehicle structure for signs of corrosion in load-bearing areas. (These include chassis box sections, side sills, cross-members, pillars, and all suspension, steering, braking system and seat belt mountings and anchorages.) Any corrosion which has seriously reduced the thickness of a load-bearing area is likely to cause the vehicle to fail. In this case professional repairs are likely to be needed.
- Damage or corrosion which causes sharp or otherwise dangerous edges to be exposed will also cause the vehicle to fail.

## 4 Checks carried out on YOUR VEHICLE'S EXHAUST EMISSION SYSTEM

### Petrol models

- Have the engine at normal operating temperature, and make sure that it is in good tune (ignition system in good order, air filter element clean, etc).
- Before any measurements are carried out, raise the engine speed to around 2500 rpm, and hold it at this speed for 20 seconds. Allow

the engine speed to return to idle, and watch for smoke emissions from the exhaust tailpipe. If the idle speed is obviously much too high, or if dense blue or clearly-visible black smoke comes from the tailpipe for more than 5 seconds, the vehicle will fail. As a rule of thumb, blue smoke signifies oil being burnt (engine wear) while black smoke signifies unburnt fuel (dirty air cleaner element, or other carburettor or fuel system fault).

- An exhaust gas analyser capable of measuring carbon monoxide (CO) and hydrocarbons (HC) is now needed. If such an instrument cannot be hired or borrowed, a local garage may agree to perform the check for a small fee.

### CO emissions (mixture)

- At the time of writing, the maximum CO level at idle is 3.5% for vehicles first used after August 1986 and 4.5% for older vehicles. From January 1996 a much tighter limit (around 0.5%) applies to catalyst-equipped vehicles first used from August 1992. If the CO level cannot be reduced far enough to pass the test (and the fuel and ignition systems are otherwise in good condition) then the carburettor is badly worn, or there is some problem in the fuel injection system or catalytic converter (as applicable).

### HC emissions

- With the CO emissions within limits, HC emissions must be no more than 1200 ppm (parts per million). If the vehicle fails this test at idle, it can be re-tested at around 2000 rpm; if the HC level is then 1200 ppm or less, this counts as a pass.
- Excessive HC emissions can be caused by oil being burnt, but they are more likely to be due to unburnt fuel.

### Diesel models

- The only emission test applicable to Diesel engines is the measuring of exhaust smoke density. The test involves accelerating the engine several times to its maximum unloaded speed.

**Note:** *It is of the utmost importance that the engine timing belt is in good condition before the test is carried out.*

- Excessive smoke can be caused by a dirty air cleaner element. Otherwise, professional advice may be needed to find the cause.

Whenever servicing, repair or overhaul work is carried out on the car or its components, observe the following procedures and instructions. This will assist in carrying out the operation efficiently and to a professional standard of workmanship.

## Joint mating faces and gaskets

When separating components at their mating faces, never insert screwdrivers or similar implements into the joint between the faces in order to prise them apart. This can cause severe damage which results in oil leaks, coolant leaks, etc upon reassembly. Separation is usually achieved by tapping along the joint with a soft-faced hammer in order to break the seal. However, note that this method may not be suitable where dowels are used for component location.

Where a gasket is used between the mating faces of two components, a new one must be fitted on reassembly; fit it dry unless otherwise stated in the repair procedure. Make sure that the mating faces are clean and dry, with all traces of old gasket removed. When cleaning a joint face, use a tool which is unlikely to score or damage the face, and remove any burrs or nicks with an oilstone or fine file.

Make sure that tapped holes are cleaned with a pipe cleaner, and keep them free of jointing compound, if this is being used, unless specifically instructed otherwise.

Ensure that all orifices, channels or pipes are clear, and blow through them, preferably using compressed air.

## Oil seals

Oil seals can be removed by levering them out with a wide flat-bladed screwdriver or similar implement. Alternatively, a number of self-tapping screws may be screwed into the seal, and these used as a purchase for pliers or some similar device in order to pull the seal free.

Whenever an oil seal is removed from its working location, either individually or as part of an assembly, it should be renewed.

The very fine sealing lip of the seal is easily damaged, and will not seal if the surface it contacts is not completely clean and free from scratches, nicks or grooves. If the original sealing surface of the component cannot be restored, and the manufacturer has not made provision for slight relocation of the seal relative to the sealing surface, the component should be renewed.

Protect the lips of the seal from any surface which may damage them in the course of fitting. Use tape or a conical sleeve where possible. Lubricate the seal lips with oil before fitting and, on dual-lipped seals, fill the space between the lips with grease.

Unless otherwise stated, oil seals must be fitted with their sealing lips toward the lubricant to be sealed.

Use a tubular drift or block of wood of the appropriate size to install the seal and, if the seal housing is shouldered, drive the seal down to the shoulder. If the seal housing is

unshouldered, the seal should be fitted with its face flush with the housing top face (unless otherwise instructed).

## Screw threads and fastenings

Seized nuts, bolts and screws are quite a common occurrence where corrosion has set in, and the use of penetrating oil or releasing fluid will often overcome this problem if the offending item is soaked for a while before attempting to release it. The use of an impact driver may also provide a means of releasing such stubborn fastening devices, when used in conjunction with the appropriate screwdriver bit or socket. If none of these methods works, it may be necessary to resort to the careful application of heat, or the use of a hacksaw or nut splitter device.

Studs are usually removed by locking two nuts together on the threaded part, and then using a spanner on the lower nut to unscrew the stud. Studs or bolts which have broken off below the surface of the component in which they are mounted can sometimes be removed using a stud extractor. Always ensure that a blind tapped hole is completely free from oil, grease, water or other fluid before installing the bolt or stud. Failure to do this could cause the housing to crack due to the hydraulic action of the bolt or stud as it is screwed in.

When tightening a castellated nut to accept a split pin, tighten the nut to the specified torque, where applicable, and then tighten further to the next split pin hole. Never slacken the nut to align the split pin hole, unless stated in the repair procedure.

When checking or retightening a nut or bolt to a specified torque setting, slacken the nut or bolt by a quarter of a turn, and then retighten to the specified setting. However, this should not be attempted where angular tightening has been used.

For some screw fastenings, notably cylinder head bolts or nuts, torque wrench settings are no longer specified for the latter stages of tightening, "angle-tightening" being called up instead. Typically, a fairly low torque wrench setting will be applied to the bolts/nuts in the correct sequence, followed by one or more stages of tightening through specified angles.

## Locknuts, locktabs and washers

Any fastening which will rotate against a component or housing during tightening should always have a washer between it and the relevant component or housing.

Spring or split washers should always be renewed when they are used to lock a critical component such as a big-end bearing retaining bolt or nut. Locktabs which are folded over to retain a nut or bolt should always be renewed.

Self-locking nuts can be re-used in non-critical areas, providing resistance can be felt when the locking portion passes over the bolt or stud thread. However, it should be noted that self-locking stiffnuts tend to lose their

effectiveness after long periods of use, and should then be renewed as a matter of course.

Split pins must always be replaced with new ones of the correct size for the hole.

When thread-locking compound is found on the threads of a fastener which is to be re-used, it should be cleaned off with a wire brush and solvent, and fresh compound applied on reassembly.

## Special tools

Some repair procedures in this manual entail the use of special tools such as a press, two or three-legged pullers, spring compressors, etc. Wherever possible, suitable readily-available alternatives to the manufacturer's special tools are described, and are shown in use. In some instances, where no alternative is possible, it has been necessary to resort to the use of a manufacturer's tool, and this has been done for reasons of safety as well as the efficient completion of the repair operation. Unless you are highly-skilled and have a thorough understanding of the procedures described, never attempt to bypass the use of any special tool when the procedure described specifies its use. Not only is there a very great risk of personal injury, but expensive damage could be caused to the components involved.

## Environmental considerations

When disposing of used engine oil, brake fluid, antifreeze, etc, give due consideration to any detrimental environmental effects. Do not, for instance, pour any of the above liquids down drains into the general sewage system, or onto the ground to soak away. Many local council refuse tips provide a facility for waste oil disposal, as do some garages. If none of these facilities are available, consult your local Environmental Health Department, or the National Rivers Authority, for further advice.

With the universal tightening-up of legislation regarding the emission of environmentally-harmful substances from motor vehicles, most vehicles have tamperproof devices fitted to the main adjustment points of the fuel system. These devices are primarily designed to prevent unqualified persons from adjusting the fuel/air mixture, with the chance of a consequent increase in toxic emissions. If such devices are found during servicing or overhaul, they should, wherever possible, be renewed or refitted in accordance with the manufacturer's requirements or current legislation.



OIL BANK LINE  
0800 66 33 66

**Note: It is antisocial and illegal to dump oil down the drain. To find the location of your local oil recycling bank, call this number free.**



## Introduction

A selection of good tools is a fundamental requirement for anyone contemplating the maintenance and repair of a motor vehicle. For the owner who does not possess any, their purchase will prove a considerable expense, offsetting some of the savings made by doing-it-yourself. However, provided that the tools purchased meet the relevant national safety standards and are of good quality, they will last for many years and prove an extremely worthwhile investment.

To help the average owner to decide which tools are needed to carry out the various tasks detailed in this manual, we have compiled three lists of tools under the following headings: *Maintenance and minor repair*, *Repair and overhaul*, and *Special*. Newcomers to practical mechanics should start off with the *Maintenance and minor repair* tool kit, and confine themselves to the simpler jobs around the vehicle. Then, as confidence and experience grow, more difficult tasks can be undertaken, with extra tools being purchased as, and when, they are needed. In this way, a *Maintenance and minor repair* tool kit can be built up into a *Repair and overhaul* tool kit over a considerable period of time, without any major cash outlays. The experienced do-it-yourselfer will have a tool kit good enough for most repair and overhaul procedures, and will add tools from the *Special* category when it is felt that the expense is justified by the amount of use to which these tools will be put.

## Maintenance and minor repair tool kit

The tools given in this list should be considered as a minimum requirement if routine maintenance, servicing and minor repair operations are to be undertaken. We recommend the purchase of combination spanners (ring one end, open-ended the other); although more expensive than open-ended ones, they do give the advantages of both types of spanner.

- Combination spanners: 8, 9, 10, 11, 12, 13, 14, 15, 16, 17, 19, 21, 22, 24 & 26 mm
- Adjustable spanner - 35 mm jaw (approx)
- Transmission drain plug key
- Set of feeler gauges
- Spark plug spanner (with rubber insert)
- Spark plug gap adjustment tool
- Brake bleed nipple spanner
- Brake adjuster spanner
- Screwdrivers: Flat blade and cross blade - approx 100 mm long x 6 mm dia
- Combination pliers
- Hacksaw (junior)
- Tyre pump
- Tyre pressure gauge
- Grease gun
- Oil can
- Oil filter removal tool
- Fine emery cloth
- Wire brush (small)
- Funnel (medium size)

## Repair and overhaul tool kit

These tools are virtually essential for anyone undertaking any major repairs to a motor vehicle, and are additional to those given in the *Maintenance and minor repair* list. Included in this list is a comprehensive set of sockets. Although these are expensive, they will be found invaluable as they are so versatile - particularly if various drives are included in the set. We recommend the half-inch square-drive type, as this can be used with most proprietary torque wrenches. If you cannot afford a socket set, even bought piecemeal, then inexpensive tubular box spanners are a useful alternative.

The tools in this list will occasionally need to be supplemented by tools from the *Special* list:

- Sockets (or box spanners) to cover range in previous list
- Reversible ratchet drive (for use with sockets) (see illustration)
- Extension piece, 250 mm (for use with sockets)
- Universal joint (for use with sockets)
- Torque wrench (for use with sockets)
- Self-locking grips
- Ball pein hammer
- Soft-faced mallet (plastic/aluminium or rubber)
- Screwdrivers:
  - Flat blade - long & sturdy, short (chubby), and narrow (electrician's) types
  - Cross blade - Long & sturdy, and short (chubby) types
- Pliers:
  - Long-nosed
  - Side cutters (electrician's)
  - Circlip (internal and external)
- Cold chisel - 25 mm
- Scriber
- Scraper
- Centre-punch
- Pin punch
- Hacksaw
- Brake hose clamp
- Brake bleeding kit
- Selection of twist drills



Sockets and reversible ratchet drive

- Steel rule/straight-edge
- Allen keys (inc. splined/Torx type) (see illustrations)
- Selection of files
- Wire brush
- Axle stands
- Jack (strong trolley or hydraulic type)
- Light with extension lead

## Special tools

The tools in this list are those which are not used regularly, are expensive to buy, or which need to be used in accordance with their manufacturers' instructions. Unless relatively difficult mechanical jobs are undertaken frequently, it will not be economic to buy many of these tools. Where this is the case, you could consider clubbing together with friends (or joining a motorists' club) to make a joint purchase, or borrowing the tools against a deposit from a local garage or tool hire specialist. It is worth noting that many of the larger DIY superstores now carry a large range of special tools for hire at modest rates.

The following list contains only those tools and instruments freely available to the public, and not those special tools produced by the vehicle manufacturer specifically for its dealer network. You will find occasional references to these manufacturers' special tools in the text of this manual. Generally, an alternative method of doing the job without the vehicle manufacturers' special tool is given. However, sometimes there is no alternative to using them. Where this is the case and the relevant tool cannot be bought or borrowed, you will have to entrust the work to a franchised garage.

- Valve spring compressor (see illustration)
- Valve grinding tool
- Piston ring compressor (see illustration)
- Piston ring removal/installation tool (see illustration)
- Cylinder bore hone (see illustration)
- Balljoint separator
- Coil spring compressors (where applicable)
- Two/three-legged hub and bearing puller (see illustration)



Spline bit set



# Tools and Working Facilities REF•7



Spline key set



Valve spring compressor



Piston ring compressor



Piston ring removal/installation tool



Cylinder bore hone



Three-legged hub and bearing puller



Micrometer set



Vernier calipers

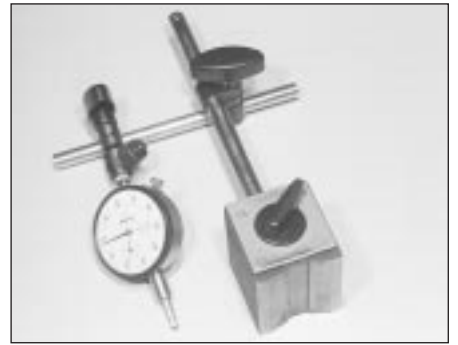

Dial test indicator and magnetic stand



Compression testing gauge



Clutch plate alignment set



Brake shoe steady spring cup removal tool

## REF•8 Tools and Working Facilities

- Impact screwdriver
- Micrometer and/or vernier calipers (*see illustrations*)
- Dial gauge (*see illustration*)
- Universal electrical multi-meter
- Cylinder compression gauge (*see illustration*)
- Clutch plate alignment set (*see illustration*)
- Brake shoe steady spring cup removal tool (*see illustration*)
- Bush and bearing removal/installation set (*see illustration*)
- Stud extractors (*see illustration*)
- Tap and die set (*see illustration*)
- Lifting tackle
- Trolley jack

### Buying tools

For practically all tools, a tool factor is the best source, since he will have a very comprehensive range compared with the average garage or accessory shop. Having said that, accessory shops often offer excellent quality tools at discount prices, so it pays to shop around.

Remember, you don't have to buy the most expensive items on the shelf, but it is always advisable to steer clear of the very cheap tools. There are plenty of good tools around at

reasonable prices, but always aim to purchase items which meet the relevant national safety standards. If in doubt, ask the proprietor or manager of the shop for advice before making a purchase.

### Care and maintenance of tools

Having purchased a reasonable tool kit, it is necessary to keep the tools in a clean and serviceable condition. After use, always wipe off any dirt, grease and metal particles using a clean, dry cloth, before putting the tools away. Never leave them lying around after they have been used. A simple tool rack on the garage or workshop wall for items such as screwdrivers and pliers is a good idea. Store all normal spanners and sockets in a metal box. Any measuring instruments, gauges, meters, etc, must be carefully stored where they cannot be damaged or become rusty.

Take a little care when tools are used. Hammer heads inevitably become marked, and screwdrivers lose the keen edge on their blades from time to time. A little timely attention with emery cloth or a file will soon restore items like this to a good serviceable finish.

### Working facilities

Not to be forgotten when discussing tools

is the workshop itself. If anything more than routine maintenance is to be carried out, some form of suitable working area becomes essential.

It is appreciated that many an owner-mechanic is forced by circumstances to remove an engine or similar item without the benefit of a garage or workshop. Having done this, any repairs should always be done under the cover of a roof.

Wherever possible, any dismantling should be done on a clean, flat workbench or table at a suitable working height.

Any workbench needs a vice; one with a jaw opening of 100 mm is suitable for most jobs. As mentioned previously, some clean dry storage space is also required for tools, as well as for any lubricants, cleaning fluids, touch-up paints and so on, which become necessary.

Another item which may be required, and which has a much more general usage, is an electric drill with a chuck capacity of at least 8 mm. This, together with a good range of twist drills, is virtually essential for fitting accessories.

Last, but not least, always keep a supply of old newspapers and clean, lint-free rags available, and try to keep any working area as clean as possible.



Bush and bearing removal/installation set



Stud extractor set

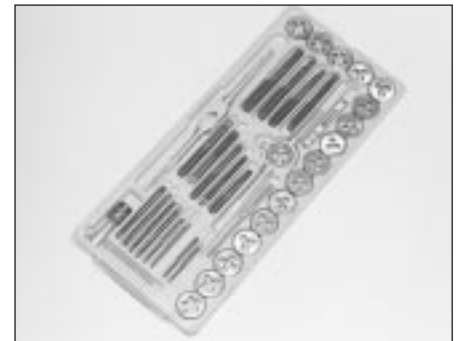

Tap and die set

## Buying spare parts

Spare parts are available from many sources, including maker's appointed garages, accessory shops, and motor factors. To be sure of obtaining the correct parts, it will sometimes be necessary to quote the vehicle identification number. If possible, it can also be useful to take the old parts along for positive identification. Items such as starter motors and alternators may be available under a service exchange scheme - any parts returned should always be clean.

Our advice regarding spare part sources is as follows.

### **Officially-appointed garages**

This is the best source of parts which are peculiar to your car, and are not otherwise generally available (eg badges, interior trim, certain body panels, etc). It is also the only place at which you should buy parts if the vehicle is still under warranty.

### **Accessory shops**

These are very good places to buy materials and components needed for the maintenance of your car (oil, air and fuel filters, spark plugs, light bulbs, drivebelts, oils and greases, brake pads, touch-up paint, etc). Components of this nature sold by a reputable shop are of the same standard as those used by the car manufacturer.

Besides components, these shops also sell tools and general accessories, usually have convenient opening hours, charge lower prices, and can often be found not far from home. Some accessory shops have parts counters where the components needed for almost any repair job can be purchased or ordered.

### **Motor factors**

Good factors will stock all the more important components which wear out comparatively quickly and can sometimes supply individual components needed for the overhaul of a larger assembly (eg brake seals and hydraulic parts, bearing shells, pistons, valves, alternator brushes). They may also handle work such as cylinder block reboring, crankshaft regrinding and balancing, etc.

### **Tyre and exhaust specialists**

These outlets may be independent or members of a local or national chain. They frequently offer competitive prices when compared with a main dealer or local garage, but it will pay to obtain several quotes before making a decision. When researching prices, also ask what 'extras' may be added - for instance, fitting a new valve and balancing the wheel are both commonly charged on top of the price of a new tyre.

### **Other sources**

Beware of parts or materials obtained from market stalls, car boot sales or similar outlets. Such items are not invariably sub-standard, but there is little chance of compensation if they do prove unsatisfactory. In the case of safety-critical components such as brake pads there is the risk not only of financial loss but also of an accident causing injury or death.

Second-hand components or assemblies obtained from a car breaker can be a good buy in some circumstances, but this sort of purchase is best made by the experienced DIY mechanic.

## Vehicle identification numbers

Modifications are a continuing and unpublicised process in vehicle manufacture, quite apart from major model changes. Spare parts manuals and lists are compiled upon a numerical basis, the individual vehicle identification numbers being essential to correct identification of the component concerned.

When ordering spare parts, always give as much information as possible. Quote the vehicle model, year of manufacture, body and engine numbers as appropriate.

The *vehicle identification plate* is located on the bonnet lock platform behind the right-hand headlight on early models, and on the left-hand door pillar below the door lock striker pin on later models. In addition to many other details, it carries the Vehicle Identification Number (VIN), maximum vehicle weight information, and codes for interior trim and body colours.

The *Vehicle Identification Number* is given on the vehicle identification plate. On later models, it is also located on a plate visible through the left-hand side of the windscreen.

The *body number and paint code numbers* are located on the vehicle identification plate.

The *engine number* location is dependent on the engine type. On 4-cylinder M-series engines (pre-1992 model year) the engine number is stamped on the rear face of the cylinder block, below the cylinder head. On 4-cylinder T-series engines (1992 model year onwards) the engine number is stamped on a plate on the forward facing side of the cylinder block just above the sump flange.

On V6 engines, the engine number is stamped on the face of the cylinder block forward facing bank, adjacent to the timing belt cover.

**Engine**

- Engine fails to rotate when attempting to start
- Engine rotates but will not start
- Engine difficult to start when cold
- Engine difficult to start when hot
- Starter motor noisy or excessively-rough in engagement
- Engine starts but stops immediately
- Engine idles erratically
- Engine misfires at idle speed
- Engine misfires throughout the driving speed range
- Engine hesitates on acceleration
- Engine stalls
- Engine lacks power
- Engine backfires
- Oil pressure warning light illuminated with engine running
- Engine runs-on after switching off
- Engine noises

**Cooling system**

- Overheating
- Overcooling
- External coolant leakage
- Internal coolant leakage
- Corrosion

**Fuel and exhaust systems**

- Excessive fuel consumption
- Fuel leakage and/or fuel odour
- Excessive noise or fumes from exhaust system

**Clutch**

- Pedal travels to floor - no pressure or very little resistance
- Clutch fails to disengage (unable to select gears)
- Clutch slips (engine speed increases with no increase in vehicle speed)
- Judder as clutch is engaged
- Noise when depressing or releasing clutch pedal

**Manual transmission**

- Noisy in neutral with engine running
- Noisy in one particular gear
- Difficulty engaging gears
- Jumps out of gear
- Vibration
- Lubricant leaks

**Automatic transmission**

- Fluid leakage
- Transmission fluid brown, or has burned smell
- General gear selection problems
- Transmission will not downshift (kickdown) with accelerator fully depressed
- Engine will not start in any gear, or starts in gears other than Park or Neutral
- Transmission slips, shifts roughly, is noisy, or has no drive in forward or reverse gears

**Driveshafts**

- Clicking or knocking noise on turns (at slow speed on full-lock)
- Vibration when accelerating or decelerating

**Braking system**

- Vehicle pulls to one side under braking
- Noise (grinding or high-pitched squeal) when brakes applied
- Excessive brake pedal travel
- Brake pedal feels spongy when depressed
- Excessive brake pedal effort required to stop vehicle
- Judder felt through brake pedal or steering wheel when braking
- Brakes binding
- Rear wheels locking under normal braking

**Suspension and steering systems**

- Vehicle pulls to one side
- Wheel wobble and vibration
- Excessive pitching and/or rolling around corners, or during braking
- Wandering or general instability
- Excessively-stiff steering
- Excessive play in steering
- Lack of power assistance
- Tyre wear excessive

**Electrical system**

- Battery will not hold a charge for more than a few days
- Ignition warning light remains illuminated with engine running
- Ignition warning light fails to come on
- Lights inoperative
- Instrument readings inaccurate or erratic
- Horn inoperative, or unsatisfactory in operation
- Windscreen/tailgate wipers inoperative, or unsatisfactory in operation
- Windscreen/tailgate washers inoperative, or unsatisfactory in operation
- Electric windows inoperative, or unsatisfactory in operation
- Central locking system inoperative, or unsatisfactory in operation



## Introduction

The vehicle owner who does his or her own maintenance according to the recommended service schedules should not have to use this section of the manual very often. Modern component reliability is such that, provided those items subject to wear or deterioration are inspected or renewed at the specified intervals, sudden failure is comparatively rare. Faults do not usually just happen as a result of sudden failure, but develop over a period of time. Major mechanical failures in particular are usually preceded by characteristic symptoms over hundreds or even thousands of miles. Those components which do occasionally fail without warning are often small and easily carried in the vehicle.

With any fault-finding, the first step is to decide where to begin investigations. Sometimes this is obvious, but on other occasions, a little detective work will be necessary. The owner who makes half a dozen haphazard adjustments or replacements may be successful in curing a fault (or its symptoms), but will be none the wiser if the fault recurs, and ultimately may have spent more time and money than was necessary. A calm and logical approach will be found to be more satisfactory in the long run. Always take into account any warning signs or abnormalities that may have been noticed in the period preceding the fault - power loss, high or low gauge readings, unusual smells, etc - and remember that failure of components such as fuses or spark plugs may only be pointers to some underlying fault.

The pages which follow provide an easy reference guide to the more common problems which may occur during the operation of the vehicle. These problems and their possible causes are grouped under

headings denoting various components or systems, such as Engine, Cooling system, etc. The Chapter and/or Section which deals with the problem is also shown in brackets. Whatever the fault, certain basic principles apply. These are as follows:

*Verify the fault.* This is simply a matter of being sure that you know what the symptoms are before starting work. This is particularly important if you are investigating a fault for someone else, who may not have described it very accurately.

*Don't overlook the obvious.* For example, if the vehicle won't start, is there petrol in the tank? (Don't take anyone else's word on this particular point, and don't trust the fuel gauge either!) If an electrical fault is indicated, look for loose or broken wires before digging out the test gear.

*Cure the disease, not the symptom.* Substituting a flat battery with a fully-charged one will get you off the hard shoulder, but if the underlying cause is not attended to, the new battery will go the same way. Similarly, changing oil-fouled spark plugs for a new set will get you moving again, but remember that the reason for the fouling (if it wasn't simply an incorrect grade of plug) will have to be established and corrected.

*Don't take anything for granted.* Particularly, don't forget that a "new" component may itself be defective (especially if it's been rattling around in the boot for months), and don't leave components out of a fault diagnosis sequence just because they are new or recently fitted. When you do finally diagnose a difficult fault, you'll probably realise that all the evidence was there from the start.

## Engine

### **Engine fails to rotate when attempting to start**

- Battery terminal connections loose or corroded (Chapter 5).
- Battery discharged or faulty (Chapter 5).
- Broken, loose or disconnected wiring in the starting circuit (Chapter 5).
- Defective starter solenoid or switch (Chapter 5).
- Defective starter motor (Chapter 5).
- Starter pinion or flywheel ring gear teeth loose or broken (Chapter 5).
- Engine earth strap broken or disconnected (Chapter 5).
- Automatic transmission not in Park/Neutral position, or selector lever position sensor faulty (Chapter 7, Part B).

### **Engine rotates but will not start**

- Fuel tank empty.
- Battery discharged (engine rotates slowly) (Chapter 5).
- Battery terminal connections loose or corroded (Chapter 5).
- Ignition components damp or damaged (Chapters 1 and 5).
- Broken, loose or disconnected wiring in the ignition circuit (Chapters 1 and 5).
- Worn, faulty or incorrectly-gapped spark plugs (Chapter 1).
- Low cylinder compressions (Chapter 2, Part A, B or C).
- Major mechanical failure (eg camshaft drive) (Chapter 2, Part A, B or C).

### **Engine difficult to start when cold**

- Battery discharged (Chapter 5).
- Battery terminal connections loose or corroded (Chapter 5).
- Worn, faulty or incorrectly-gapped spark plugs (Chapter 1).
- Other ignition system fault (Chapters 1 and 5).
- Engine management system fault (Chapters 1 and 4).
- Low cylinder compressions (Chapter 2, Part A, B or C).

### **Engine difficult to start when hot**

- Air filter element dirty or clogged (Chapter 1).
- Engine management system fault (Chapters 1 and 4).
- Low cylinder compressions (Chapter 2, Part A, B or C).
- Faulty hydraulic tappet(s) (Chapter 2, Part A, B or C).

### **Starter motor noisy or excessively-rough in engagement**

- Starter pinion or flywheel ring gear teeth loose or broken (Chapter 5).
- Starter motor mounting bolts loose or missing (Chapter 5).
- Starter motor internal components worn or damaged (Chapter 5).

### **Engine starts but stops immediately**

- Loose or faulty electrical connections in the ignition circuit (Chapters 1 and 5).
- Engine management system fault (Chapters 1 and 4).
- Vacuum leak at the inlet manifold (Chapters 1, 2 and 4).

### **Engine idles erratically**

- Engine management system fault (Chapters 1 and 4).
- Air filter element clogged (Chapter 1).
- Vacuum leak at the inlet manifold or associated hoses (Chapters 1, 2 and 4).
- Worn, faulty or incorrectly-gapped spark plugs (Chapter 1).
- Faulty hydraulic tappet(s) (Chapter 2, Part A, B or C).
- Uneven or low cylinder compressions (Chapter 2, Part A, B or C).
- Camshaft lobes worn (Chapter 2, Part A, B or C).
- Timing belt incorrectly-tensioned (Chapter 2, Part A or B).

## Engine (continued)

### **Engine misfires at idle speed**

- Worn, faulty or incorrectly-gapped spark plugs (Chapter 1).
- Faulty spark plug HT leads (Chapter 1).
- Incorrect ignition timing (Chapter 5).
- Engine management system fault (Chapters 1 and 4).
- Vacuum leak at the inlet manifold or associated hoses (Chapters 1, 2 and 4).
- Faulty hydraulic tappet(s) (Chapter 2, Part A, B or C).
- Uneven or low cylinder compressions (Chapter 2, Part A, B or C).
- Disconnected, leaking or perished crankcase ventilation hoses (Chapters 1 and 4).

### **Engine misfires throughout the driving speed range**

- Fuel filter choked (Chapter 1).
- Fuel pump faulty or delivery pressure low (Chapter 4).
- Fuel tank vent blocked or fuel pipes restricted (Chapter 4).
- Vacuum leak at the inlet manifold or associated hoses (Chapters 1, 2 and 4).
- Worn, faulty or incorrectly-gapped spark plugs (Chapter 1).
- Faulty spark plug HT leads (Chapter 1).
- Faulty ignition coil (Chapter 5).
- Engine management system fault (Chapters 1 and 4).
- Uneven or low cylinder compressions (Chapter 2, Part A, B or C).

### **Engine hesitates on acceleration**

- Worn, faulty or incorrectly-gapped spark plugs (Chapter 1).
- Engine management system fault (Chapters 1 and 4).
- Vacuum leak at the inlet manifold or associated hoses (Chapters 1, 2 and 4).

### **Engine stalls**

- Engine management system fault (Chapters 1 and 4).
- Vacuum leak at the inlet manifold or associated hoses (Chapters 1, 2 and 4).
- Fuel filter choked (Chapter 1).
- Fuel pump faulty or delivery pressure low (Chapter 4).
- Fuel tank vent blocked or fuel pipes restricted (Chapter 4).

### **Engine lacks power**

- Incorrect ignition timing (Chapter 5).
- Engine management system fault (Chapters 1 and 4).
- Timing belt incorrectly fitted or incorrectly tensioned (Chapter 2, Part A or B).
- Fuel filter choked (Chapter 1).
- Fuel pump faulty or delivery pressure low (Chapter 4).
- Uneven or low cylinder compressions (Chapter 2, Part A, B or C).
- Worn, faulty or incorrectly-gapped spark plugs (Chapter 1).
- Vacuum leak at the inlet manifold or associated hoses (Chapters 1, 2 and 4).
- Brakes binding (Chapters 1 and 9).
- Clutch slipping (Chapter 6).
- Automatic transmission fluid level incorrect (Chapter 1).

### **Engine backfires**

- Ignition timing incorrect (Chapter 5).
- Engine management system fault (Chapters 1 and 4).
- Timing belt incorrectly fitted or incorrectly tensioned (Chapter 2, Part A or B).
- Vacuum leak at the inlet manifold or associated hoses (Chapters 1, 2 and 4).

### **Oil pressure warning light illuminated with engine running**

- Low oil level or incorrect oil grade (Chapter 1).
- Faulty oil pressure warning light switch (Chapter 2, Part A, B or C).
- Worn engine bearings and/or oil pump (Chapter 2, Part A, B or C).
- High engine operating temperature (Chapter 3).
- Oil pressure relief valve defective (Chapter 2, Part A, B or C).
- Oil pick-up strainer clogged (Chapter 2, Part A, B or C).

### **Engine runs-on after switching off**

- Idle speed excessively high (Chapter 4).
- Engine management system fault (Chapters 1 and 4).
- Excessive carbon build-up in engine (Chapter 2, Part A, B or C).
- High engine operating temperature (Chapter 3).

### **Engine noises**

#### **Pre-ignition (pinking) or knocking during acceleration or under load**

- Ignition timing incorrect (Chapter 5).
- Incorrect grade of fuel (Chapter 4).
- Vacuum leak at the inlet manifold or associated hoses (Chapters 1, 2 and 4).
- Excessive carbon build-up in engine (Chapter 2, Part A, B or C).

#### **Whistling or wheezing noises**

- Leaking inlet manifold gasket (Chapter 2, Part A, B or C).
- Leaking exhaust manifold gasket or downpipe-to-manifold joint (Chapters 1, 2 Part A, B or C, and 4).
- Leaking vacuum hose (Chapters 1, 2, 4, and 9).
- Blowing cylinder head gasket (Chapter 2, Part A, B or C).

#### **Tapping or rattling noises**

- Faulty hydraulic tappet(s) (Chapter 2, Part A, B or C).
- Worn valve gear or camshaft (Chapter 2, Part A, B or C).
- Worn timing belt or tensioner (Chapter 2, Part A, B or C).
- Ancillary component fault (water pump, alternator, etc) (Chapters 3 and 5).

#### **Knocking or thumping noises**

- Worn big-end bearings (regular heavy knocking, perhaps less under load) (Chapter 2, Part C).
- Worn main bearings (rumbling and knocking, perhaps worsening under load) (Chapter 2, Part C).
- Piston slap (most noticeable when cold) (Chapter 2, Part C).
- Ancillary component fault (water pump, alternator, etc) (Chapters 3 and 5).

## Cooling system

### **Overheating**

- Insufficient coolant in system (Chapter 1).
- Thermostat faulty (Chapter 3).
- Radiator core blocked or grille restricted (Chapter 3).
- Radiator electric cooling fan(s) or coolant temperature sensor faulty (Chapter 3).
- Engine management system fault (Chapters 1 and 4).
- Pressure cap faulty (Chapter 3).
- Auxiliary drivebelt worn or slipping (Chapter 1).
- Ignition timing incorrect (Chapter 5).
- Inaccurate coolant temperature gauge sender (Chapter 3).
- Air-lock in cooling system (Chapter 1).

### **Overcooling**

- Thermostat faulty (Chapter 3).
- Inaccurate coolant temperature gauge sender (Chapter 3).

### **External coolant leakage**

- Deteriorated or damaged hoses or hose clips (Chapter 1).
- Radiator core or heater matrix leaking (Chapter 3).
- Pressure cap faulty (Chapter 3).
- Water pump seal leaking (Chapter 3).
- Boiling due to overheating (Chapter 3).
- Core plug leaking (Chapter 2, Part C).

### **Internal coolant leakage**

- Leaking cylinder head gasket (Chapter 2, Part A, B or C).
- Cracked cylinder head or cylinder bore (Chapter 2, Part C).

### **Corrosion**

- Infrequent draining and flushing (Chapter 1).
- Incorrect antifreeze mixture, or inappropriate antifreeze type (Chapter 1).

## Fuel and exhaust system

### **Excessive fuel consumption**

- Unsympathetic driving style, or adverse conditions.
- Air filter element dirty or clogged (Chapter 1).
- Engine management system fault (Chapters 1 and 4).
- Ignition timing incorrect (Chapter 5).
- Tyres under-inflated (Chapter 1).

### **Fuel leakage and/or fuel odour**

- Damaged or corroded fuel tank, pipes or connections (Chapter 1).
- Charcoal canister and/or connecting pipes leaking (Chapter 4, Part E).

### **Excessive noise or fumes from exhaust system**

- Leaking exhaust system or manifold joints (Chapters 1, 2 Part A, B or C, and 4).
- Leaking, corroded or damaged silencers or pipe (Chapter 1).
- Broken mountings, causing body or suspension contact (Chapters 1 and 4).

## Clutch

### **Pedal travels to floor - no pressure or very little resistance**

- Air in clutch hydraulic system (Chapter 6).
- Faulty clutch slave cylinder (Chapter 6).
- Faulty clutch master cylinder (Chapter 6).
- Incorrect pedal height adjustment (Chapter 6).
- Broken diaphragm spring in clutch pressure plate (Chapter 6).

### **Clutch fails to disengage (unable to select gears)**

- Air in clutch hydraulic system (Chapter 6).
- Faulty clutch slave cylinder (Chapter 6).
- Faulty clutch master cylinder (Chapter 6).
- Incorrect pedal height adjustment (Chapter 6).
- Clutch disc sticking on transmission mainshaft splines (Chapter 6).
- Clutch disc sticking to flywheel or pressure plate (Chapter 6).
- Faulty pressure plate assembly (Chapter 6).
- Clutch release mechanism worn or incorrectly assembled (Chapter 6).

### **Clutch slips (engine speed increases with no increase in vehicle speed)**

- Clutch disc linings excessively worn (Chapter 6).
- Clutch disc linings contaminated with oil or grease (Chapter 6).
- Faulty pressure plate or weak diaphragm spring (Chapter 6).

### **Judder as clutch is engaged**

- Clutch disc linings contaminated with oil or grease (Chapter 6).
- Clutch disc linings excessively worn (Chapter 6).
- Faulty or distorted pressure plate or diaphragm spring (Chapter 6).
- Worn or loose engine/transmission mountings (Chapter 2, Part A or B).
- Clutch disc hub or transmission mainshaft splines worn (Chapter 6).

### **Noise when depressing or releasing clutch pedal**

- Worn clutch release bearing (Chapter 6).
- Worn or dry clutch pedal bushes (Chapter 6).
- Faulty pressure plate assembly (Chapter 6).
- Pressure plate diaphragm spring broken (Chapter 6).
- Broken clutch disc cushioning springs (Chapter 6).

## Manual transmission

### Noisy in neutral with engine running

- Mainshaft bearings worn (noise apparent with clutch pedal released, but not when depressed) (Chapter 7, Part A).\*
- Clutch release bearing worn (noise apparent with clutch pedal depressed, possibly less when released) (Chapter 6).

### Noisy in one particular gear

- Worn, damaged or chipped gear teeth (Chapter 7, Part A).\*
- Worn bearings (Chapter 7, Part A).\*

### Difficulty engaging gears

- Clutch fault (Chapter 6).
- Worn or damaged gear linkage (Chapter 7, Part A).
- Worn synchroniser assemblies (Chapter 7, Part A).\*

### Vibration

- Lack of oil (Chapter 1).
- Worn bearings (Chapter 7, Part A).\*

### Jumps out of gear

- Worn or damaged gear linkage (Chapter 7, Part A).
- Worn synchroniser assemblies (Chapter 7, Part A).\*
- Worn selector forks (Chapter 7, Part A).\*

### Lubricant leaks

- Leaking differential side gear oil seal (Chapter 7, Part A).
- Leaking gearchange shaft or speedometer pinion oil seals (Chapter 7, Part A).
- Leaking housing joint (Chapter 7, Part A).\*
- Leaking mainshaft oil seal (Chapter 7, Part A).\*

\* Although the corrective action necessary to remedy the symptoms described is beyond the scope of the home mechanic, the above information should be helpful in isolating the cause of the condition, so that the owner can communicate clearly with a professional mechanic.

## Automatic transmission

**Note:** Due to the complexity of the automatic transmission, it is difficult for the home mechanic to properly diagnose and service this unit. For problems other than the following, the vehicle should be taken to a dealer service department or automatic transmission specialist.

### Fluid leakage

- Automatic transmission fluid is usually dark in colour. Fluid leaks should not be confused with engine oil, which can easily be blown onto the transmission by airflow.
- To determine the source of a leak, first remove all built-up dirt and grime from the transmission housing and surrounding areas, using a degreasing agent, or by steam-cleaning. Drive the vehicle at low speed, so airflow will not blow the leak far from its source. Raise and support the vehicle, and determine where the leak is coming from. The following are common areas of leakage:
  - (a) Transmission oil sump (Chapters 1 and 7, Part B).
  - (b) Dipstick tube (Chapters 1 and 7, Part B).
  - (c) Transmission-to-fluid cooler pipes/unions (Chapter 7, Part B).
  - (d) Speedometer drive pinion O-ring (Chapter 7, Part B).
  - (d) Differential side gear oil seals (Chapter 7, Part B).

### Transmission fluid brown, or has burned smell

- Transmission fluid level low, or fluid in need of renewal (Chapter 1).

### Transmission will not downshift (kickdown) with accelerator pedal fully depressed

- Low transmission fluid level (Chapter 1).
- Incorrect kickdown cable adjustment (Chapter 7, Part B).
- Incorrect selector cable adjustment (Chapter 7, Part B).
- Engine management system fault (Chapters 1, and 4).

### General gear selection problems

- Chapter 7, Part B, deals with checking and adjusting the selector cable on automatic transmissions. The following are common problems which may be caused by a poorly-adjusted cable:
  - (a) Engine starting in gears other than Park or Neutral.
  - (b) Indicator on gear selector lever pointing to a gear other than the one actually being used.
  - (c) Vehicle moves when in Park or Neutral.
  - (d) Poor gear shift quality or erratic gear changes.
 Refer to Chapter 7, Part B for the selector cable adjustment procedure.

### Engine will not start in any gear, or starts in gears other than Park or Neutral

- Incorrect selector cable adjustment (Chapter 7, Part B).
- Incorrect starter inhibitor switch adjustment (Chapter 7, Part B).

### Transmission slips, shift roughly, is noisy, or has no drive in forward or reverse gears

- There are many probable causes for the above problems, but the home mechanic should be concerned with only one possibility - fluid level. Before taking the vehicle to a dealer or transmission specialist, check the fluid level and condition of the fluid as described in Chapter 1. Correct the fluid level as necessary, or change the fluid if needed. If the problem persists, professional help will be necessary.

## Driveshafts

### Clicking or knocking noise on turns (at slow speed on full-lock)

- Lack of constant velocity joint lubricant (Chapter 8).
- Worn outer constant velocity joint (Chapter 8).

### Vibration when accelerating or decelerating

- Worn inner constant velocity joint (Chapter 8).
- Bent or distorted driveshaft (Chapter 8).



## Braking system

**Note:** Before assuming that a brake problem exists, make sure that the tyres are in good condition and correctly inflated, that the front wheel alignment is correct, and that the vehicle is not loaded with weight in an unequal manner. Apart from checking the condition of all pipe and hose connections, any faults occurring on the Anti-lock Braking System (ABS) should be referred to a Rover dealer for diagnosis.

### Vehicle pulls to one side under braking

- Worn, defective, damaged or contaminated front or rear brake pads on one side (Chapter 1).
- Seized or partially-seized front or rear brake caliper piston (Chapter 9).
- A mixture of brake pad lining materials fitted between sides (Chapter 1).
- Brake caliper mounting bolts loose (Chapter 9).
- Worn or damaged steering or suspension components (Chapter 10).

### Noise (grinding or high-pitched squeal) when brakes applied

- Brake pad friction lining material worn down to metal backing (Chapter 1).
- Excessive corrosion of brake disc (may be apparent after the vehicle has been standing for some time) (Chapter 1).

### Excessive brake pedal travel

- Faulty master cylinder (Chapter 9).
- Air in hydraulic system (Chapter 9).

### Brake pedal feels spongy when depressed

- Air in hydraulic system (Chapter 9).
- Deteriorated flexible rubber brake hoses (Chapter 9).
- Master cylinder mounting nuts loose (Chapter 9).
- Faulty master cylinder (Chapter 9).

### Excessive brake pedal effort required to stop vehicle

- Faulty vacuum servo unit (Chapter 9).
- Disconnected, damaged or insecure brake servo vacuum hose (Chapter 9).
- Primary or secondary hydraulic circuit failure (Chapter 9).
- Seized brake caliper piston(s) (Chapter 9).
- Brake pads incorrectly fitted (Chapter 9).
- Incorrect grade of brake pads fitted (Chapter 1).
- Brake pad linings contaminated (Chapter 1).

### Judder felt through brake pedal or steering wheel when braking

- Excessive run-out or distortion of front or rear discs (Chapter 9).
- Brake pad linings worn (Chapter 1).
- Brake caliper mounting bolts loose (Chapter 9).
- Wear in suspension or steering components or mountings (Chapter 10).

### Brakes binding

- Seized brake caliper piston(s) (Chapter 9).
- Faulty handbrake mechanism (Chapter 9).
- Faulty master cylinder (Chapter 9).

### Rear wheels locking under normal braking

- Rear brake pad linings contaminated (Chapter 1).
- Faulty brake pressure-reducing valve (Chapter 9).

## Suspension and steering systems

**Note:** Before diagnosing suspension or steering faults, be sure that the trouble is not due to incorrect tyre pressures, mixtures of tyre types, or binding brakes.

### Vehicle pulls to one side

- Defective tyre (Chapter 1).
- Excessive wear in suspension or steering components (Chapter 10).
- Incorrect front or rear wheel alignment (Chapter 10).
- Accident damage to steering or suspension components (Chapter 10).

### Wheel wobble and vibration

- Front roadwheels out of balance (vibration felt mainly through the steering wheel) (Chapter 1).
- Rear roadwheels out of balance (vibration felt throughout the vehicle) (Chapter 1).
- Roadwheels damaged or distorted (Chapter 1).
- Faulty or damaged tyre (Chapter 1).
- Worn steering or suspension joints, bushes or components (Chapter 10).
- Roadwheel nuts loose (Chapter 1).

### Excessive pitching and/or rolling around corners, or during braking

- Defective shock absorbers (Chapter 10).
- Broken or weak coil spring and/or suspension component (Chapter 10).
- Worn or damaged anti-roll bar or mountings (Chapter 10).

### Wandering or general instability

- Incorrect front or rear wheel alignment (Chapter 10).
- Worn steering or suspension joints, bushes or components (Chapter 10).
- Roadwheels out of balance (Chapter 1).
- Faulty or damaged tyre (Chapter 1).
- Roadwheel nuts loose (Chapter 1).
- Defective shock absorbers (Chapter 10).

### Excessively-stiff steering

- Broken or incorrectly adjusted power steering pump (auxiliary) drivebelt (Chapters 1 and 10).
- Power steering pump faulty (Chapter 10).
- Seized track rod end balljoint or suspension balljoint (Chapter 10).
- Incorrect front wheel alignment (Chapter 10).
- Steering rack or column bent or damaged (Chapter 10).

## Suspension and steering systems

### **Excessive play in steering**

- Worn steering column universal joint(s) (Chapter 10).
- Worn steering track rod end balljoints (Chapter 10).
- Worn rack-and-pinion steering gear (Chapter 10).
- Worn steering or suspension joints, bushes or components (Chapter 10).

### **Lack of power assistance**

- Broken or slipping power steering pump (auxiliary) drivebelt (Chapter 1).
- Incorrect power steering fluid level (Chapter 1).
- Restriction in power steering fluid hoses (Chapter 10).
- Faulty power steering pump (Chapter 10).
- Faulty rack-and-pinion steering gear (Chapter 10).

### **Tyre wear excessive**

#### **Tyre treads exhibit feathered edges**

- Incorrect toe setting (Chapter 10).

#### **Tyres worn in centre of tread**

- Tyres over-inflated (Chapter 1).

#### **Tyres worn on inside and outside edges**

- Tyres under-inflated (Chapter 1).

#### **Tyres worn unevenly**

- Tyres out of balance (Chapter 1).
- Excessive wheel or tyre run-out (Chapter 1).
- Worn shock absorbers (Chapter 10).
- Faulty tyre (Chapter 1).

#### **Tyres worn on inside or outside edges**

- Tyres under-inflated (wear on both edges) (Chapter 1).
- Incorrect camber or castor angles (wear on one edge only) (Chapter 10).
- Worn steering or suspension joints, bushes or components (Chapter 10).
- Excessively-hard cornering.
- Accident damage.

## Electrical system

**Note:** For problems associated with the starting system, refer to the faults listed under "Engine" earlier in this Section.

### **Battery will not hold a charge for more than a few days**

- Battery defective internally (Chapters 1 and 5).
- Battery electrolyte level low (Chapter 1).
- Battery terminal connections loose or corroded (Chapters 1 and 5).
- Auxiliary drivebelt worn or incorrectly-adjusted (Chapter 1).
- Alternator not charging at correct output (Chapter 5).
- Alternator or voltage regulator faulty (Chapter 5).
- Short-circuit causing continual battery drain (Chapters 5 and 12).

### **Ignition warning light remains illuminated with engine running**

- Auxiliary drivebelt broken, worn, or incorrectly-adjusted (Chapter 1).
- Alternator brushes worn, sticking, or dirty (Chapter 5).
- Alternator brush springs weak or broken (Chapter 5).
- Internal fault in alternator or voltage regulator (Chapter 5).
- Broken, disconnected, or loose wiring in charging circuit (Chapter 5).

### **Ignition warning light fails to come on**

- Warning light bulb blown (Chapter 12).
- Broken, disconnected, or loose wiring in warning light circuit (Chapters 5 and 12).
- Alternator faulty (Chapter 5).

### **Lights inoperative**

- Bulb blown (Chapter 12).
- Corrosion of bulb or bulbholder contacts (Chapter 12).
- Blown fuse (Chapter 12).
- Faulty relay (Chapter 12).
- Broken, loose, or disconnected wiring (Chapter 12).
- Faulty switch (Chapter 12).

### **Instrument readings inaccurate or erratic**

#### **Instrument readings increase with engine speed**

- Faulty instrument electronic control unit (Chapter 12).

#### **Fuel or temperature gauges give no reading**

- Faulty instrument electronic control unit (Chapter 12).
- Faulty gauge sender unit (Chapters 3 or 4).
- Wiring open-circuit (Chapter 12).
- Faulty gauge (Chapter 12).

#### **Fuel or temperature gauges give continuous maximum reading**

- Faulty instrument electronic control unit (Chapter 12).
- Faulty gauge sender unit (Chapters 3 or 4).
- Wiring short-circuit (Chapter 12).
- Faulty gauge (Chapter 12).

### **Horn inoperative, or unsatisfactory in operation**

#### **Horn fails to operate**

- Blown fuse (Chapter 12).
- Steering wheel cable connections loose, broken or disconnected (Chapter 10).
- Faulty horn (Chapter 12).

#### **Horn emits intermittent or unsatisfactory sound**

- Steering wheel cable connections loose, broken or disconnected (Chapter 10).
- Horn mountings loose (Chapter 12).
- Faulty horn (Chapter 12).

#### **Horn operates all the time**

- Horn push either earthed or stuck down (Chapter 10).
- Steering wheel cable connections earthed (Chapter 10).

### **Windscreen/tailgate wipers inoperative or unsatisfactory in operation**

#### **Wipers fail to operate, or operate very slowly**

- Wiper blades stuck to screen, or linkage seized or binding (Chapter 12).
- Blown fuse (Chapter 12).
- Cable or cable connections loose, broken or disconnected (Chapter 12).
- Faulty relay (Chapter 12).
- Faulty wiper motor (Chapter 12).

## **Wiper blades sweep over too large or too small an area of the glass**

- Wiper arms incorrectly-positioned on spindles (Chapter 1).
- Excessive wear of wiper linkage (Chapter 1).
- Wiper motor or linkage mountings loose or insecure (Chapter 12).

## **Wiper blades fail to clean the glass effectively**

- Wiper blade rubbers worn or perished (Chapter 1).
- Wiper arm tension springs broken, or arm pivots seized (Chapter 1).
- Insufficient windscreen washer additive to adequately remove road film (Chapter 1).

## ***Windscreen/tailgate washers inoperative, or unsatisfactory in operation***

### **One or more washer jets inoperative**

- Blocked washer jet (Chapter 1).
- Disconnected, kinked or restricted fluid hose (Chapter 1).
- Insufficient fluid in washer reservoir (Chapter 1).

### **Washer pump fails to operate**

- Broken or disconnected wiring or connections (Chapter 12).
- Blown fuse (Chapter 12).
- Faulty washer switch (Chapter 12).
- Faulty washer pump (Chapter 12).

### **Washer pump runs for some time before fluid is emitted from jets**

- Faulty one-way valve in fluid supply hose (Chapter 12).

## ***Electric windows inoperative, or unsatisfactory in operation***

### **Window glass will only move in one direction**

- Faulty switch (Chapter 12).

### **Window glass slow to move**

- Incorrectly-adjusted door glass guide channels (Chapter 11).
- Regulator seized or damaged, or in need of lubrication (Chapter 11).
- Door internal components or trim fouling regulator (Chapter 11).
- Faulty motor (Chapter 12).

### **Window glass fails to move**

- Incorrectly-adjusted door glass guide channels (Chapter 11).
- Blown fuse (Chapter 12).
- Faulty relay (Chapter 12).
- Broken or disconnected wiring or connections (Chapter 12).
- Faulty motor (Chapter 12).

## ***Central locking system inoperative, or unsatisfactory in operation***

### **Complete system failure**

- Inertia cut-off switch tripped out (Chapter 11).
- Blown fuse (Chapter 12).
- Faulty relay (Chapter 12).
- Broken or disconnected wiring or connections (Chapter 12).

### **Latch locks but will not unlock, or unlocks but will not lock**

- Faulty master switch (Chapter 11).
- Broken or disconnected latch operating rods or levers (Chapter 11).
- Faulty relay (Chapter 12).

### **One lock motor fails to operate**

- Broken or disconnected wiring or connections (Chapter 12).
- Faulty lock motor (Chapter 11).
- Broken, binding or disconnected latch operating rods or levers (Chapter 11).
- Fault in door latch (Chapter 11).

## A

**ABS (Anti-lock brake system)** A system, usually electronically controlled, that senses incipient wheel lockup during braking and relieves hydraulic pressure at wheels that are about to skid.

**Air bag** An inflatable bag hidden in the steering wheel (driver's side) or the dash or glovebox (passenger side). In a head-on collision, the bags inflate, preventing the driver and front passenger from being thrown forward into the steering wheel or windshield.

**Air cleaner** A metal or plastic housing, containing a filter element, which removes dust and dirt from the air being drawn into the engine.

**Air filter element** The actual filter in an air cleaner system, usually manufactured from pleated paper and requiring renewal at regular intervals.

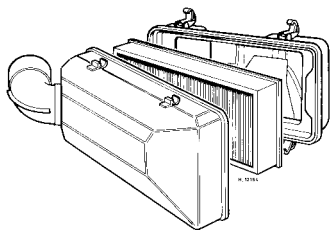

Air filter

**Allen key** A hexagonal wrench which fits into a recessed hexagonal hole.

**Alligator clip** A long-nosed spring-loaded metal clip with meshing teeth. Used to make temporary electrical connections.

**Alternator** A component in the electrical system which converts mechanical energy from a drivebelt into electrical energy to charge the battery and to operate the starting system, ignition system and electrical accessories.

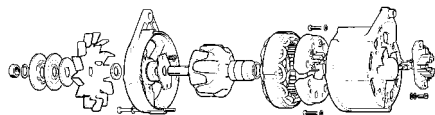

Alternator (exploded view)

**Ampere (amp)** A unit of measurement for the flow of electric current. One amp is the amount of current produced by one volt acting through a resistance of one ohm.

**Anaerobic sealer** A substance used to prevent bolts and screws from loosening. Anaerobic means that it does not require oxygen for activation. The Loctite brand is widely used.

**Antifreeze** A substance (usually ethylene glycol) mixed with water, and added to a vehicle's cooling system, to prevent freezing of the coolant in winter. Antifreeze also contains chemicals to inhibit corrosion and the formation of rust and other deposits that

would tend to clog the radiator and coolant passages and reduce cooling efficiency.

**Anti-seize compound** A coating that reduces the risk of seizing on fasteners that are subjected to high temperatures, such as exhaust manifold bolts and nuts.



Anti-seize compound

**Asbestos** A natural fibrous mineral with great heat resistance, commonly used in the composition of brake friction materials. Asbestos is a health hazard and the dust created by brake systems should never be inhaled or ingested.

**Axle** A shaft on which a wheel revolves, or which revolves with a wheel. Also, a solid beam that connects the two wheels at one end of the vehicle. An axle which also transmits power to the wheels is known as a live axle.

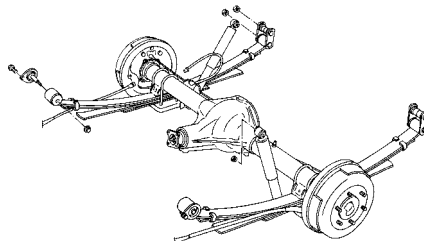

Axle assembly

**Axleshaft** A single rotating shaft, on either side of the differential, which delivers power from the final drive assembly to the drive wheels. Also called a driveshaft or a halfshaft.

## B

**Ball bearing** An anti-friction bearing consisting of a hardened inner and outer race with hardened steel balls between two races.



Bearing

**Bearing** The curved surface on a shaft or in a bore, or the part assembled into either, that permits relative motion between them with minimum wear and friction.

**Big-end bearing** The bearing in the end of the connecting rod that's attached to the crankshaft.

**Bleed nipple** A valve on a brake wheel cylinder, caliper or other hydraulic component that is opened to purge the hydraulic system of air. Also called a bleed screw.

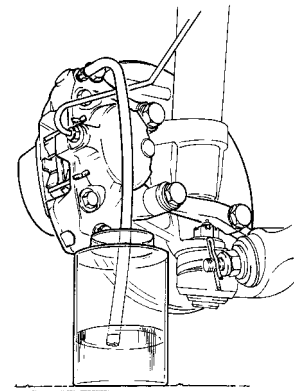

Brake bleeding

**Brake bleeding** Procedure for removing air from lines of a hydraulic brake system.

**Brake disc** The component of a disc brake that rotates with the wheels.

**Brake drum** The component of a drum brake that rotates with the wheels.

**Brake linings** The friction material which contacts the brake disc or drum to retard the vehicle's speed. The linings are bonded or riveted to the brake pads or shoes.

**Brake pads** The replaceable friction pads that pinch the brake disc when the brakes are applied. Brake pads consist of a friction material bonded or riveted to a rigid backing plate.

**Brake shoe** The crescent-shaped carrier to which the brake linings are mounted and which forces the lining against the rotating drum during braking.

**Braking systems** For more information on braking systems, consult the *Haynes Automotive Brake Manual*.

**Breaker bar** A long socket wrench handle providing greater leverage.

**Bulkhead** The insulated partition between the engine and the passenger compartment.

## C

**Caliper** The non-rotating part of a disc-brake assembly that straddles the disc and carries the brake pads. The caliper also contains the hydraulic components that cause the pads to pinch the disc when the brakes are applied. A caliper is also a measuring tool that can be set to measure inside or outside dimensions of an object.



**Camshaft** A rotating shaft on which a series of cam lobes operate the valve mechanisms. The camshaft may be driven by gears, by sprockets and chain or by sprockets and a belt.

**Canister** A container in an evaporative emission control system; contains activated charcoal granules to trap vapours from the fuel system.



*Canister*

**Carburettor** A device which mixes fuel with air in the proper proportions to provide a desired power output from a spark ignition internal combustion engine.

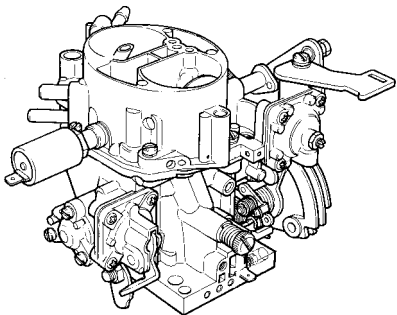

*Carburettor*

**Castellated** Resembling the parapets along the top of a castle wall. For example, a castellated balljoint stud nut.



*Castellated nut*

**Castor** In wheel alignment, the backward or forward tilt of the steering axis. Castor is positive when the steering axis is inclined rearward at the top.

**Catalytic converter** A silencer-like device in the exhaust system which converts certain pollutants in the exhaust gases into less harmful substances.

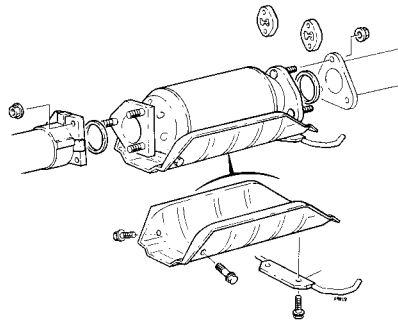

*Catalytic converter*

**Circlip** A ring-shaped clip used to prevent endwise movement of cylindrical parts and shafts. An internal circlip is installed in a groove in a housing; an external circlip fits into a groove on the outside of a cylindrical piece such as a shaft.

**Clearance** The amount of space between two parts. For example, between a piston and a cylinder, between a bearing and a journal, etc.

**Coil spring** A spiral of elastic steel found in various sizes throughout a vehicle, for example as a springing medium in the suspension and in the valve train.

**Compression** Reduction in volume, and increase in pressure and temperature, of a gas, caused by squeezing it into a smaller space.

**Compression ratio** The relationship between cylinder volume when the piston is at top dead centre and cylinder volume when the piston is at bottom dead centre.

**Constant velocity (CV) joint** A type of universal joint that cancels out vibrations caused by driving power being transmitted through an angle.

**Core plug** A disc or cup-shaped metal device inserted in a hole in a casting through which core was removed when the casting was formed. Also known as a freeze plug or expansion plug.

**Crankcase** The lower part of the engine block in which the crankshaft rotates.

**Crankshaft** The main rotating member, or shaft, running the length of the crankcase, with offset "throws" to which the connecting rods are attached.

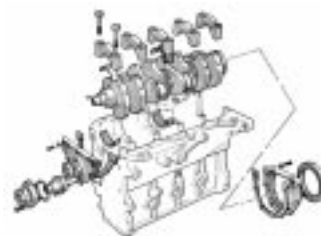

*Crankshaft assembly*

**Crocodile clip** See Alligator clip

## D

**Diagnostic code** Code numbers obtained by accessing the diagnostic mode of an engine management computer. This code can be used to determine the area in the system where a malfunction may be located.

**Disc brake** A brake design incorporating a rotating disc onto which brake pads are squeezed. The resulting friction converts the energy of a moving vehicle into heat.

**Double-overhead cam (DOHC)** An engine that uses two overhead camshafts, usually one for the intake valves and one for the exhaust valves.

**Drivebelt(s)** The belt(s) used to drive accessories such as the alternator, water pump, power steering pump, air conditioning compressor, etc. off the crankshaft pulley.

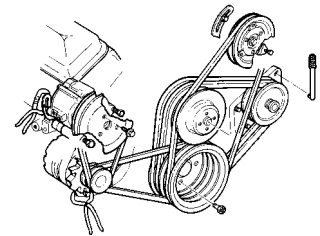

*Accessory drivebelts*

**Driveshaft** Any shaft used to transmit motion. Commonly used when referring to the axleshafts on a front wheel drive vehicle.

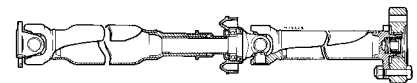

*Driveshaft*

**Drum brake** A type of brake using a drum-shaped metal cylinder attached to the inner surface of the wheel. When the brake pedal is pressed, curved brake shoes with friction linings press against the inside of the drum to slow or stop the vehicle.

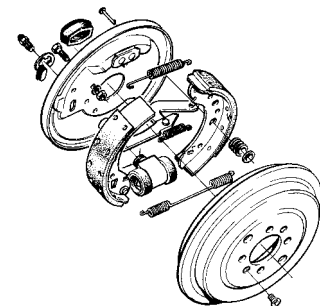

*Drum brake assembly*

**E**

**EGR valve** A valve used to introduce exhaust gases into the intake air stream.

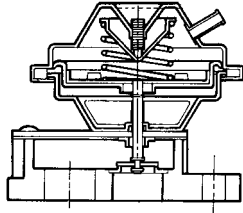

EGR valve

**Electronic control unit (ECU)** A computer which controls (for instance) ignition and fuel injection systems, or an anti-lock braking system. For more information refer to the *Haynes Automotive Electrical and Electronic Systems Manual*.

**Electronic Fuel Injection (EFI)** A computer controlled fuel system that distributes fuel through an injector located in each intake port of the engine.

**Emergency brake** A braking system, independent of the main hydraulic system, that can be used to slow or stop the vehicle if the primary brakes fail, or to hold the vehicle stationary even though the brake pedal isn't depressed. It usually consists of a hand lever that actuates either front or rear brakes mechanically through a series of cables and linkages. Also known as a handbrake or parking brake.

**Endfloat** The amount of lengthwise movement between two parts. As applied to a crankshaft, the distance that the crankshaft can move forward and back in the cylinder block.

**Engine management system (EMS)** A computer controlled system which manages the fuel injection and the ignition systems in an integrated fashion.

**Exhaust manifold** A part with several passages through which exhaust gases leave the engine combustion chambers and enter the exhaust pipe.

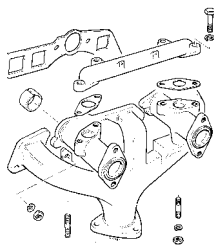

Exhaust manifold

**F**

**Fan clutch** A viscous (fluid) drive coupling device which permits variable engine fan speeds in relation to engine speeds.

**Feeler blade** A thin strip or blade of hardened steel, ground to an exact thickness, used to check or measure clearances between parts.



Feeler blade

**Firing order** The order in which the engine cylinders fire, or deliver their power strokes, beginning with the number one cylinder.

**Flywheel** A heavy spinning wheel in which energy is absorbed and stored by means of momentum. On cars, the flywheel is attached to the crankshaft to smooth out firing impulses.

**Free play** The amount of travel before any action takes place. The "looseness" in a linkage, or an assembly of parts, between the initial application of force and actual movement. For example, the distance the brake pedal moves before the pistons in the master cylinder are actuated.

**Fuse** An electrical device which protects a circuit against accidental overload. The typical fuse contains a soft piece of metal which is calibrated to melt at a predetermined current flow (expressed as amps) and break the circuit.

**Fusible link** A circuit protection device consisting of a conductor surrounded by heat-resistant insulation. The conductor is smaller than the wire it protects, so it acts as the weakest link in the circuit. Unlike a blown fuse, a failed fusible link must frequently be cut from the wire for replacement.

**G**

**Gap** The distance the spark must travel in jumping from the centre electrode to the side



Adjusting spark plug gap

electrode in a spark plug. Also refers to the spacing between the points in a contact breaker assembly in a conventional points-type ignition, or to the distance between the reluctor or rotor and the pickup coil in an electronic ignition.

**Gasket** Any thin, soft material - usually cork, cardboard, asbestos or soft metal - installed between two metal surfaces to ensure a good seal. For instance, the cylinder head gasket seals the joint between the block and the cylinder head.

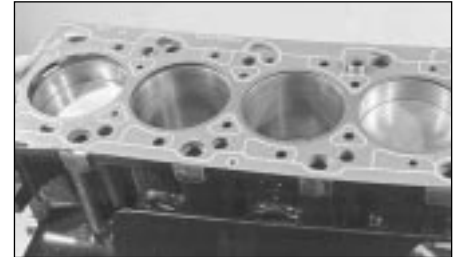

Gasket

**Gauge** An instrument panel display used to monitor engine conditions. A gauge with a movable pointer on a dial or a fixed scale is an analogue gauge. A gauge with a numerical readout is called a digital gauge.

**H**

**Halfshaft** A rotating shaft that transmits power from the final drive unit to a drive wheel, usually when referring to a live rear axle.

**Harmonic balancer** A device designed to reduce torsion or twisting vibration in the crankshaft. May be incorporated in the crankshaft pulley. Also known as a vibration damper.

**Hone** An abrasive tool for correcting small irregularities or differences in diameter in an engine cylinder, brake cylinder, etc.

**Hydraulic tappet** A tappet that utilises hydraulic pressure from the engine's lubrication system to maintain zero clearance (constant contact with both camshaft and valve stem). Automatically adjusts to variation in valve stem length. Hydraulic tappets also reduce valve noise.

**I**

**Ignition timing** The moment at which the spark plug fires, usually expressed in the number of crankshaft degrees before the piston reaches the top of its stroke.

**Inlet manifold** A tube or housing with passages through which flows the air-fuel mixture (carburettor vehicles and vehicles with throttle body injection) or air only (port fuel-injected vehicles) to the port openings in the cylinder head.

## J

**Jump start** Starting the engine of a vehicle with a discharged or weak battery by attaching jump leads from the weak battery to a charged or helper battery.

## L

**Load Sensing Proportioning Valve (LSPV)** A brake hydraulic system control valve that works like a proportioning valve, but also takes into consideration the amount of weight carried by the rear axle.

**Locknut** A nut used to lock an adjustment nut, or other threaded component, in place. For example, a locknut is employed to keep the adjusting nut on the rocker arm in position.

**Lockwasher** A form of washer designed to prevent an attaching nut from working loose.

## M

**MacPherson strut** A type of front suspension system devised by Earle MacPherson at Ford of England. In its original form, a simple lateral link with the anti-roll bar creates the lower control arm. A long strut - an integral coil spring and shock absorber - is mounted between the body and the steering knuckle. Many modern so-called MacPherson strut systems use a conventional lower A-arm and don't rely on the anti-roll bar for location.

**Multimeter** An electrical test instrument with the capability to measure voltage, current and resistance.

## N

**NOx** Oxides of Nitrogen. A common toxic pollutant emitted by petrol and diesel engines at higher temperatures.

## O

**Ohm** The unit of electrical resistance. One volt applied to a resistance of one ohm will produce a current of one amp.

**Ohmmeter** An instrument for measuring electrical resistance.

**O-ring** A type of sealing ring made of a special rubber-like material; in use, the O-ring is compressed into a groove to provide the sealing action.



O-ring

**Overhead cam (ohc) engine** An engine with the camshaft(s) located on top of the cylinder head(s).

**Overhead valve (ohv) engine** An engine with the valves located in the cylinder head, but with the camshaft located in the engine block.

**Oxygen sensor** A device installed in the engine exhaust manifold, which senses the oxygen content in the exhaust and converts this information into an electric current. Also called a Lambda sensor.

## P

**Phillips screw** A type of screw head having a cross instead of a slot for a corresponding type of screwdriver.

**Plastigage** A thin strip of plastic thread, available in different sizes, used for measuring clearances. For example, a strip of Plastigage is laid across a bearing journal. The parts are assembled and dismantled; the width of the crushed strip indicates the clearance between journal and bearing.



Plastigage

**Propeller shaft** The long hollow tube with universal joints at both ends that carries power from the transmission to the differential on front-engined rear wheel drive vehicles.

**Proportioning valve** A hydraulic control valve which limits the amount of pressure to the rear brakes during panic stops to prevent wheel lock-up.

## R

**Rack-and-pinion steering** A steering system with a pinion gear on the end of the steering shaft that mates with a rack (think of a geared wheel opened up and laid flat). When the steering wheel is turned, the pinion turns, moving the rack to the left or right. This movement is transmitted through the track rods to the steering arms at the wheels.

**Radiator** A liquid-to-air heat transfer device designed to reduce the temperature of the coolant in an internal combustion engine cooling system.

**Refrigerant** Any substance used as a heat transfer agent in an air-conditioning system. R-12 has been the principle refrigerant for many years; recently, however, manufacturers have begun using R-134a, a non-CFC substance that is considered less harmful to

the ozone in the upper atmosphere.

**Rocker arm** A lever arm that rocks on a shaft or pivots on a stud. In an overhead valve engine, the rocker arm converts the upward movement of the pushrod into a downward movement to open a valve.

**Rotor** In a distributor, the rotating device inside the cap that connects the centre electrode and the outer terminals as it turns, distributing the high voltage from the coil secondary winding to the proper spark plug. Also, that part of an alternator which rotates inside the stator. Also, the rotating assembly of a turbocharger, including the compressor wheel, shaft and turbine wheel.

**Runout** The amount of wobble (in-and-out movement) of a gear or wheel as it's rotated. The amount a shaft rotates "out-of-true." The out-of-round condition of a rotating part.

## S

**Sealant** A liquid or paste used to prevent leakage at a joint. Sometimes used in conjunction with a gasket.

**Sealed beam lamp** An older headlight design which integrates the reflector, lens and filaments into a hermetically-sealed one-piece unit. When a filament burns out or the lens cracks, the entire unit is simply replaced.

**Serpentine drivebelt** A single, long, wide accessory drivebelt that's used on some newer vehicles to drive all the accessories, instead of a series of smaller, shorter belts. Serpentine drivebelts are usually tensioned by an automatic tensioner.

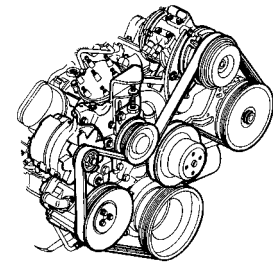

Serpentine drivebelt

**Shim** Thin spacer, commonly used to adjust the clearance or relative positions between two parts. For example, shims inserted into or under bucket tappets control valve clearances. Clearance is adjusted by changing the thickness of the shim.

**Slide hammer** A special puller that screws into or hooks onto a component such as a shaft or bearing; a heavy sliding handle on the shaft bottoms against the end of the shaft to knock the component free.

**Sprocket** A tooth or projection on the periphery of a wheel, shaped to engage with a chain or drivebelt. Commonly used to refer to the sprocket wheel itself.

**Starter inhibitor switch** On vehicles with an

automatic transmission, a switch that prevents starting if the vehicle is not in Neutral or Park.

**Strut** See MacPherson strut.

## T

**Tappet** A cylindrical component which transmits motion from the cam to the valve stem, either directly or via a pushrod and rocker arm. Also called a cam follower.

**Thermostat** A heat-controlled valve that regulates the flow of coolant between the cylinder block and the radiator, so maintaining optimum engine operating temperature. A thermostat is also used in some air cleaners in which the temperature is regulated.

**Thrust bearing** The bearing in the clutch assembly that is moved in to the release levers by clutch pedal action to disengage the clutch. Also referred to as a release bearing.

**Timing belt** A toothed belt which drives the camshaft. Serious engine damage may result if it breaks in service.

**Timing chain** A chain which drives the camshaft.

**Toe-in** The amount the front wheels are closer together at the front than at the rear. On rear wheel drive vehicles, a slight amount of toe-in is usually specified to keep the front wheels running parallel on the road by offsetting other forces that tend to spread the wheels apart.

**Toe-out** The amount the front wheels are closer together at the rear than at the front. On

front wheel drive vehicles, a slight amount of toe-out is usually specified.

**Tools** For full information on choosing and using tools, refer to the *Haynes Automotive Tools Manual*.

**Tracer** A stripe of a second colour applied to a wire insulator to distinguish that wire from another one with the same colour insulator.

**Tune-up** A process of accurate and careful adjustments and parts replacement to obtain the best possible engine performance.

**Turbocharger** A centrifugal device, driven by exhaust gases, that pressurises the intake air. Normally used to increase the power output from a given engine displacement, but can also be used primarily to reduce exhaust emissions (as on VW's "Umwelt" Diesel engine).

## U

**Universal joint or U-joint** A double-pivoted connection for transmitting power from a driving to a driven shaft through an angle. A U-joint consists of two Y-shaped yokes and a cross-shaped member called the spider.

## V

**Valve** A device through which the flow of liquid, gas, vacuum, or loose material in bulk may be started, stopped, or regulated by a movable part that opens, shuts, or partially

obstructs one or more ports or passageways. A valve is also the movable part of such a device.

**Valve clearance** The clearance between the valve tip (the end of the valve stem) and the rocker arm or tappet. The valve clearance is measured when the valve is closed.

**Vernier caliper** A precision measuring instrument that measures inside and outside dimensions. Not quite as accurate as a micrometer, but more convenient.

**Viscosity** The thickness of a liquid or its resistance to flow.

**Volt** A unit for expressing electrical "pressure" in a circuit. One volt that will produce a current of one ampere through a resistance of one ohm.

## W

**Welding** Various processes used to join metal items by heating the areas to be joined to a molten state and fusing them together. For more information refer to the *Haynes Automotive Welding Manual*.

**Wiring diagram** A drawing portraying the components and wires in a vehicle's electrical system, using standardised symbols. For more information refer to the *Haynes Automotive Electrical and Electronic Systems Manual*.



Note: References throughout this index relate to Chapter•page number

## A

Accelerator cable - 1•13, 4A•3, 4B•3, 4C•2, 4D•3  
 Accelerator pedal - 4A•3, 4B•3, 4C•3, 4C•4, 4D•3  
 Acknowledgements - 0•4  
 Aerial amplifier - 12•16  
 Air bags - 0•5  
 Air cleaner - 1•15, 4A•2, 4B•2, 4C•2, 4D•2  
 Air conditioning - 1•17, 1•18, 1•19, 3•3, 3•11, 3•12, 12•8  
 Air duct - 4D•3  
 Air intake trunking - 4D•2  
 Air suction valve - 4E•3, 4E•4  
 Airbag - 12•18  
 Airflow meter - 4B•5  
 Alarm siren - 12•17  
 Alternator - 1•16, 1•17, 1•18, 5•10  
 Amplifier - 12•17  
 Anti-lock braking system - 9•16, 9•17  
 Anti-roll bar - 10•8, 10•11  
 Anti-theft system - 0•10, 12•17  
 Antifreeze - 1•1, 1•3, 1•9, 1•25, 1•26, 3•3  
 Asbestos - 0•5  
 ATF - 1•3, 1•22, 1•24  
 Atmospheric pressure sensor - 4D•6  
 Automatic transmission - 2A•17, 2B•11, 2C•3, 2C•7, 7B•1 *et seq*  
 Automatic transmission fault finding - REF•14  
 Automatic transmission fluid - 1•3, 1•22, 1•24

## B

Backfire - REF•12  
 Battery - 0•5, 1•9, 1•15, 5•2, 5•3  
 Battery fault - REF•16  
 Big-end bearings - 2C•15, 2C•18  
 Bleeding brakes - 9•2  
 Bleeding clutch - 6•2  
 Bleeding power steering - 10•17  
 Blower motor - 3•9, 3•10, 3•13  
 Body electrical system - 12•1 *et seq*  
 Bodywork and fittings - 1•22, 11•1 *et seq*, REF•4  
 Bonnet - 1•22, 11•4, 11•5, 12•18  
 Boost control solenoid - 4C•5

Boot - 1•22, 11•5, 11•6, 11•8  
 Brake band - 7B•8  
 Brake fluid - 1•3, 1•9, 1•25  
 Braking system - 1•21, 1•22, 1•26, 4D•10, 9•1 *et seq*, REF•1, REF•2, REF•3  
 Braking system fault finding - REF•15  
 Bulbs - 12•6, 12•8  
 Bumpers - 11•16  
 Burning - 0•5

## C

Cables - 1•13, 3•11, 4A•3, 4B•3, 4C•2, 4D•3, 7B•3 to 7B•6, 9•14, 9•15, 11•5 to 11•7, 11•14, 11•18  
 Caliper - 9•5, 9•7, 9•8  
 Camshaft - 2A•4, 2A•10, 2A•11, 2B•4, 2B•7, 2B•8, 4C•5  
 Capacities - 1•3  
 Carpets - 11•2  
 Cassette - 0•10, 11•2, 11•14, 12•15  
 Catalytic converter - 4E•4  
 CD player - 11•2, 12•15  
 Central control unit - 12•12  
 Central locking fault - REF•17  
 Centre console - 11•19, 12•5  
 Charcoal canister - 4E•2  
 Charging - 1•16, 5•9  
 Circuit board - 12•12  
 Clock - 12•12  
 Clutch - 1•21, 1•22, 4D•10, 6•1 *et seq*  
 Clutch fault finding - REF•13  
 Clutch fluid - 1•3  
 CO content - 1•20, REF•4  
 Coil - 5•5  
 Coil spring - 10•6, 10•10  
 Compact disc player - 11•2, 12•15  
 Compression test - 2A•3, 2B•3  
 Compressor - 3•12  
 Condenser - 3•12  
 Connecting rods - 2C•11, 2C•12, 2C•14, 2C•18  
 Console - 11•19, 12•5  
 Constant vacuum control valve - 4E•3  
 Constant velocity joint - 1•21, 8•3, 8•4  
 Contents - 0•2  
 Conversion factors - 0•11  
 Coolant - 1•1, 1•3, 1•9, 1•25, 1•26, 3•3  
 Coolant pump - 3•7, 3•9

Coolant temperature gauge - 12•11, 12•12  
 Coolant temperature gauge fault - REF•16  
 Cooling, heating and air conditioning systems - 1•13, 3•1 *et seq*  
 Cooling system fault finding - REF•13  
 Courtesy light - 12•5, 12•8  
 Crankcase - 2C•12  
 Crankcase emissions control - 4E•1, 4E•2  
 Crankshaft - 2A•10, 2A•16, 2B•5, 2B•8, 2B•11, 2C•12, 2C•15, 2C•17  
 Crankshaft sensor - 5•9  
 Cruise control system - 4D•9, 4D•10  
 Crushing - 0•5  
 CV joints - 1•21, 8•3, 8•4  
 Cylinder block - 2C•12  
 Cylinder head - 2A•12, 2B•4, 2B•10, 2C•9, 2C•10, 2C•11  
 Cylinder sensor - 5•9

## D

Dashpot diaphragm - 4D•7  
 Dents in bodywork - 11•3  
 Depressurisation - fuel system - 4A•3, 4B•3, 4C•3, 4D•3  
 Differential - 7A•4  
 Dimensions - 0•6  
 Direction indicators - 12•6  
 Discs - 9•6, 9•8  
 Distributor - 1•14, 5•4, 5•5  
 Doors - 1•22, 11•9, 11•11, 11•12, 11•13, 11•14, 11•15, 11•16, 12•5, REF•2  
 Drivebelts - 1•16, 1•17, 1•18  
 Driveplate - 2A•16, 2B•11  
 Driveshafts - 1•21, 8•1 *et seq*, REF•3  
 Driveshafts fault finding - REF•14  
 Drivetrain - 1•22

## E

Earth fault - 12•2  
 EGR valve - 4E•4  
 Electric shock - 0•5  
 Electric windows - 11•14, 11•16  
 Electric windows fault - REF•17  
 Electrical system - 1•15, 1•19, 1•22, REF•2  
 Electrical system fault finding - 12•2, REF•16  
 Electrolyte - 1•9

Electronic control unit (ECU) - 4A•7, 4A•8, 4B•7, 4C•5, 4D•9, 4D•10, 5•8, 7B•9, 9•17, 12•11  
 Electronic idle control valve - 4D•7  
 Emissions control equipment - 1•26, 4E•2  
 Engine compartment - 1•19, 12•7  
*Engine electrical systems* - 5•1 *et seq*  
 Engine fault - REF•11  
 Engine oil - 1•3, 1•8, 1•11  
*Engine removal and general engine overhaul procedures* - 2C•1 *et seq*  
 Environmental considerations - REF•5  
 Evaporative emissions control - 4E•1, 4E•2  
 Evaporator - 3•13  
 Exhaust emissions control - 4E•1, 4E•3, REF•4  
 Exhaust manifold - 2A•6, 2B•5  
 Exhaust system - 1•21, 4A•9, 4B•8, 4C•6, 4D•10, - REF•3  
 Exhaust system fault - REF•13

## F

Faceplate - 12•11, 12•12  
 Facia - 11•20, 12•6, 12•8  
 Fan - 3•5, 3•13  
 Fast idle valve - 4D•7  
*Fault finding* - REF•10 *et seq*  
*Fault finding - braking system* - REF•15  
*Fault finding - central locking* - REF•17  
*Fault finding - clutch* - REF•13  
*Fault finding - cooling system* - REF•13  
*Fault finding - driveshafts* - REF•14  
*Fault finding - electric windows* - REF•17  
*Fault finding - electrical system* - 12•2, REF•16  
*Fault finding - engine* - REF•11  
*Fault finding - fuel and exhaust system* - REF•13, REF•16  
*Fault finding - ignition system* - REF•16  
*Fault finding - manual transmission* - REF•14  
*Fault finding - suspension and steering systems* - REF•15  
 Filling - 11•3  
 Filter, EGR - 4E•4  
 Filter, fuel - 1•24  
 Filter, oil - 1•1, 1•11, 2B•10  
 Filter, transmission fluid - 7B•3  
 Fire - 0•5  
 Fluid level checks - 1•8  
 Flywheel - 2A•16, 2B•11  
 Fog light - 12•7  
 Footwell lights - 12•8  
*4-cylinder engine - in-car engine repair procedures* - 2A•1 *et seq*  
 Fuel and exhaust systems - REF•4  
 Fuel and exhaust system fault finding - REF•13  
*Fuel and exhaust systems - Emissions control systems* - 4E•1 *et seq*  
*Fuel and exhaust systems - Honda PGM-Fi injection engines* - 4D•1 *et seq*  
*Fuel and exhaust systems - Lucas multi-point injection engines* - 4B•1 *et seq*  
*Fuel and exhaust systems - MEMS multi-point injection engines* - 4C•1 *et seq*

*Fuel and exhaust systems - single-point injection engines* - 4A•1 *et seq*  
 Fuel consumption high - REF•13  
 Fuel filler flap - 11•6, 11•7  
 Fuel filter - 1•24  
 Fuel gauge - 4A•4, 4B•3, 4C•3, 4D•3, 12•11, 12•12  
 Fuel gauge fault - REF•16  
 Fuel injectors - 4B•7, 4C•5, 4D•7  
 Fuel line - 1•13, 1•21  
 Fuel pressure regulator - 4B•7, 4C•4, 4D•8  
 Fuel pump - 4A•4, 4B•3, 4C•3, 4D•3  
 Fuel rail - 4C•5, 4D•7, 4D•8  
 Fuel tank - 4A•4, 4B•3, 4C•3, 4D•4  
 Fuel temperature sensor - 4C•4  
 Fuel temperature switch - 4B•6  
 Fume or gas intoxication - 0•5  
 Fusebox - 12•3, 12•4

## G

Gaiters - 1•21, 8•4, 10•16  
 Gashes in bodywork - 11•3  
 Gaskets - REF•5  
 Gear lever - 7A•2  
 Glass - 11•9, 11•13, 11•16  
*Glossary of technical terms* - REF•18 *et seq*  
 Glovebox lights - 12•8  
 Grille - 11•8

## H

Handbrake - 9•13, 9•14, 9•15, REF•1  
 Handles - 11•12, 11•15, 11•16  
 Hazard warning - 12•8  
 HC emissions - REF•4  
 Headlight - 12•6, 12•8, 12•9  
 Headlight washer - 1•9, 1•11, 12•15  
 Heater - 3•3, 3•9, 3•10, 3•11, 12•8  
 Horn - 12•13  
 Horn fault - REF•16  
 HT leads - 1•14  
 Hubs - 10•5, 10•9  
 Hydraulic modulator - 9•17  
 Hydraulic pipes and hoses - 9•12  
 Hydraulic tappets - 2A•11, 2B•8  
 Hydrofluoric acid - 0•5

## I

Idle speed adjustment - 1•20, 4A•6, 4B•4, 4D•5  
 Idle speed stepper motor - 4B•5  
 Idling fault - REF•11  
 Igniter - 5•6  
 Ignition coil - 5•5  
 Ignition fault - REF•16  
 Ignition switch - 12•4  
 Ignition timing - 5•6, 5•7  
 Indicators - 12•6  
 Inertia switch - 4A•9, 4B•7, 4C•5, 4D•9  
 Injector housing - 4A•7  
 Injectors - 4B•7, 4C•5, 4D•7, 4D•8  
 Inlet air temperature sensor - 4A•7, 4C•4  
 Inlet manifold - 2A•4, 2B•5  
 Instrument cowl - 12•5  
 Instrument panel - 1•22, 12•8, 12•9, 12•11, 12•10, 12•12

Instrument fault - REF•16  
 Intercooler - 3•7, 4C•6  
 Interior light - 12•5, 12•8  
 Intermediate shaft - 8•4, 8•5  
 Introduction to the Rover 800 - 0•4

## J

Jacking - 0•7  
 Jump starting - 0•9

## K

Kickdown cable - 7B•3, 7B•4  
 Knock sensor - 5•8  
 Knuckle - 10•4, 10•5

## L

Lazy locking - 11•2  
 Leaks - 0•10, REF•13, REF•14  
 Light units - 12•8  
 Lights fault - REF•16  
 Locknuts, locktabs and washers - REF•5  
 Locks - 10•13, 11•5, 11•7, 11•8, 11•11, 11•12, 11•16, 12•4  
 Lower suspension arm - 10•7  
 Lubricants and fluids - 1•3  
 Luggage compartment light - 12•8

## M

Main bearings - 2C•15, 2C•17  
 Main control box - 4D•9  
 Maintenance schedule - 1•4  
 Manifold heater - 4A•9  
 Manifolds - 2A•4, 2A•6, 2B•5  
 Manual transmission fault - REF•14  
*Manual transmission* - 1•20, 2A•17, 2B•11, 2C•3, 2C•7, 7A•1 *et seq*  
 Manual transmission oil - 1•3, 1•20, 1•25  
 Map reading light - 12•8  
 Master cylinder - 6•4, 6•5, 9•9, 9•11  
 Mating faces - REF•5  
 Mirror - 11•2, 11•15, 12•8, REF•1  
 Misfire - 5•4, REF•12  
 Mixture - 1•20  
 Mixture adjustment - 4A•6, 4B•4, 4D•5  
*MOT test checks* - REF•1 *et seq*  
 Mountings - 2A•17, 2B•11

## N

Neutral switch - 7A•4  
 Number plate light - 12•7, 12•9

## O

Oil cooler - 2B•10, 7B•9  
 Oil filter - 1•1, 1•11, 2B•10  
 Oil pressure fault - REF•12  
 Oil pressure gauge - 12•11  
 Oil pump - 2A•15, 2B•11  
 Oil seals - 2A•10, 2A•16, 2B•8, 2B•11, 7A•4, 7B•9, REF•5  
 Oil, engine - 1•3, 1•8, 1•11  
 Oil, manual transmission - 1•3, 1•20, 1•25

Open-circuit - 12•2  
 Over-voltage protection relay - 9•17  
 Overcooling - REF•13  
 Overheating - REF•13  
 Oxygen sensor - 4E•3

## P

Pads - 9•3, 9•6  
 Paint - 1•22  
 Pedals - 4A•3, 4B•3, 4C•3, 4C•4, 4D•3, 6•6, 9•12  
 Pinking - REF•12  
 Piston rings - 2C•16  
 Pistons - 2C•11, 2C•12, 2C•14, 2C•18  
 Plastic components - 11•4  
 Plenum chamber - 4B•6, 4C•5  
 Poisonous or irritant substances - 0•5  
 Positive Crankcase Ventilation (PCV) system - 1•23  
 Power amplifier - 12•17  
 Power steering - 1•17, 1•18, 10•17, 10•19  
 Power steering fluid - 1•3, 1•10, 1•11  
 Pre-ignition - REF•12  
 Pressure-reducing valve - 9•11  
 Printed circuit - 12•11, 12•12  
 Project vehicles - 0•4  
 Purge control valve solenoid - 4E•2

## Q

Quarter light glass - 11•16

## R

Radiator - 3•6, 3•7, 11•8  
 Radio - 0•10, 11•2, 12•15  
 Rear light cluster - 12•7, 12•8, 12•9  
 Rear window - 11•9  
 Receiver/dryer - 3•13  
 Regulator (window) - 11•16  
 Relay - 4C•5, 9•17, 12•3  
 Release bearing - 6•3  
 Repair procedures - REF•5  
 Resonator - 4A•9, 4B•7, 4D•6  
 Respraying - 11•3  
 Reversing light - 7A•4, 7B•8  
 Road test - 1•22  
 Rockers - 2B•4, 2C•9, 2C•10, 2C•11  
 Rotary coupler - 10•13  
 Rotor arm - 5•4  
 Routine maintenance - bodywork and underframe - 11•2  
 Routine maintenance - upholstery and carpets - 11•2  
*Routine maintenance and servicing* - 1•1 *et seq*  
 Rubber gaiters - 1•21, 8•4, 10•16  
 Rust holes in bodywork - 11•3

## S

Safety first - 0•5  
 Scalding - 0•5  
 Scratches in bodywork - 11•3  
 Screw threads and fastenings - REF•5  
 Seat belts - 1•16, 11•18, REF•2  
 Seats - 11•2, 11•17, 11•18, REF•2  
 Selector cable - 7B•4, 7B•5, 7B•6  
 Selector lever - 7B•7, 7B•8  
 Servo unit - 9•16  
 Shock absorbers - 10•6, 10•10, REF•2, REF•3  
 Short-circuit - 12•2  
 Sidelight - 12•6  
 Slave cylinder - 6•6  
 Snubber - 2A•18  
 Spares - REF•9  
 Spark plugs - 1•13  
 Speakers - 12•16  
 Speedometer - 7A•3, 7A•4, 7B•8, 12•11, 12•12  
 Spring - 10•6, 10•10, REF•3  
 Starter inhibitor - 7B•8  
 Starter motor - 5•12  
 Starter motor fault - REF•11  
 Starting system - 5•11  
 Steering - 1•20, 1•22, 10•4, 10•12 to 10•17, 10•19, 12•4, 12•8, REF•1, REF•2, REF•3  
 Stepper motor unit - 4A•8  
 Stop-light switch - 9•15  
 Sump - 2A•14, 2B•10, 7B•3  
 Sun roof - 11•2, 11•19  
*Suspension and steering systems* - 1•20, 1•22, 10•1 *et seq*, REF•2, REF•3  
 Suspension and steering systems fault finding - REF•15  
 Switch illumination - 12•8  
 Switches - 3•5, 4A•7, 4A•9, 4B•6, 4B•7, 4C•4, 4C•5, 4D•9, 4D•10, 7A•4, 7B•8, 9•15, 12•4, 12•18

## T

Tachometer - 12•11, 12•12  
 Tailgate - 1•22, 11•6, 11•7, 11•8, 11•9  
 Tappets - 2A•11, 2B•8, 2B•9  
 Temperature gauge - 12•11, 12•12  
 Temperature gauge fault - REF•16  
 Thermax switch - 4A•7  
 Thermostat - 3•3  
 Thermostatic valve - 4E•2  
 Throttle body - 4A•8, 4D•6  
 Throttle housing - 4B•6, 4C•4  
 Throttle potentiometer - 4A•7, 4B•6, 4C•4  
 Tie-bar - 2A•18, 10•8  
 Timing - 5•6, 5•7  
 Timing belt - 1•23, 1•26, 2A•6, 2A•9, 2A•10, 2B•5, 2B•6, 2B•7

Toe setting - 10•20  
 Tools - REF•5, REF•6, REF•8  
 Top Dead Centre (TDC) for number 1 piston - 2B•3  
 Towing - 0•8  
 Track rod - 10•15  
 Trailing link - 10•11  
 Transverse link - 10•11  
 Trim panel - 1•22, 11•9, 11•15  
 Trip computer - 12•13  
 Turbocharger - 4B•7, 4B•8, 4C•6  
 Tweeter - 12•16  
 Tyres - 1•10, REF•4  
 Tyre fault - REF•16

## U

Underbody - 1•21  
 Underframe - 11•2  
 Unleaded petrol - 4A•4, 4B•3, 4C•3, 4D•4  
 Upholstery - 11•2  
 Upper suspension arm - 10•7

## V

*V6 engine - in-car engine repair procedures* - 2B•1 *et seq*  
 Vacuum hoses - 1•13  
 Vacuum servo unit - 9•16  
 Valve block - 7B•3  
 Valves - 2B•4, 2C•10, 2C•11  
 Vehicle identification - REF•2, REF•9  
 Vehicle map - 12•13  
 Ventilation - 3•9  
 Voltage regulator - 5•10  
 Voltmeter - 12•11

## W

Warning lights - 12•8, 12•10, 12•12  
 Washer system - 1•9, 1•11, 12•15  
 Washer fault - REF•17  
 Water pump - 3•7, 3•9  
 Weekly checks - 1•8  
 Weights - 0•6  
 Wheel alignment - 10•19  
 Wheel bearings - 10•5, 10•9, REF•3  
 Wheel changing - 0•8  
 Wheel speed sensor - 9•18, 9•19  
 Wheels - 1•20, 1•22, REF•4  
 Wheels lock - REF•15  
 Windows - 11•2, 11•9, 11•13, 11•14, 11•16  
 Windscreen - 11•9, REF•1  
 Wiper arms - 12•13  
 Wiper blades - 1•11  
 Wiper fault - REF•16  
 Wiper linkage - 12•14  
 Wiper motor - 12•13, 12•15  
*Wiring diagrams* - 12•19 *et seq*  
 Working facilities - REF•8

# Preserving Our Motoring Heritage



<  
The Model J Duesenberg Derham Tourster. Only eight of these magnificent cars were ever built – this is the only example to be found outside the United States of America

Almost every car you've ever loved, loathed or desired is gathered under one roof at the Haynes Motor Museum. Over 300 immaculately presented cars and motorbikes represent every aspect of our motoring heritage, from elegant reminders of bygone days, such as the superb Model J Duesenberg to curiosities like the bug-eyed BMW Isetta. There are also many old friends and flames. Perhaps you remember the 1959 Ford Popular that you did your courting in? The magnificent 'Red Collection' is a spectacle of classic sports cars including AC, Alfa Romeo, Austin Healey, Ferrari, Lamborghini, Maserati, MG, Riley, Porsche and Triumph.

## A Perfect Day Out

Each and every vehicle at the Haynes Motor Museum has played its part in the history and culture of Motoring. Today, they make a wonderful spectacle and a great day out for all the family. Bring the kids, bring Mum and Dad, but above all bring your camera to capture those golden memories for ever. You will also find an impressive array of motoring memorabilia, a comfortable 70 seat video cinema and one of the most extensive transport book shops in Britain. The Pit Stop Cafe serves everything from a cup of tea to wholesome, home-made meals or, if you prefer, you can enjoy the large picnic area nestled in the beautiful rural surroundings of Somerset.



>  
John Haynes O.B.E.,  
Founder and  
Chairman of the  
museum at the wheel  
of a Haynes Light 12.

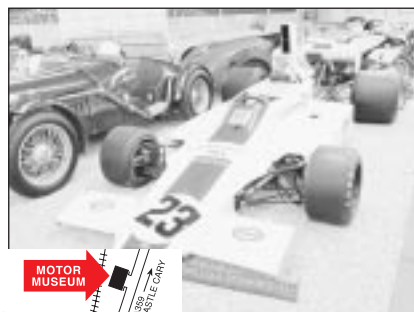

<  
Graham Hill's Lola  
Cosworth Formula 1  
car next to a 1934  
Riley Sports.

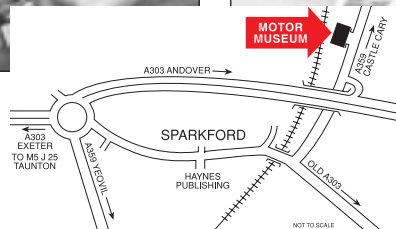

The Museum is situated on the A359 Yeovil to Frome road at Sparkford, just off the A303 in Somerset. It is about 40 miles south of Bristol, and 25 minutes drive from the M5 intersection at Taunton.

Open 9.30am - 5.30pm (10.00am - 4.00pm Winter) 7 days a week, except Christmas Day, Boxing Day and New Years Day  
Special rates available for schools, coach parties and outings Charitable Trust No. 292048